

# DISCOVERY



## Electrical troubleshooting manual

---

Elektrische diagnoseprocedure-handboek

Manuel de dépannage électrique

Handbuch zur Fehlersuche bei elektrischen Bauteilen

Manuale per l'individuazione dei guasti elettrici

Manual de localización de averías eléctricas

Manual de diagnóstico de averías eléctricas



# Electrical troubleshooting manual

## DISCOVERY

1995 model

### CONTENTS

<b>Section Title</b>	
i	Introduction
A1	Multipoint Fuel Injection (MFI-V8)
A2	Multipoint Fuel Injection (MFI-T16)
A4	300Tdi
A5	300Tdi Glow Plug Control
B1	Starting and Charging
B5	Cruise Control
C1	Ignition and Shift Interlock
D1	Anti-Lock Brake System
E1	Instruments
E2	Warnings and Indicators
E5	Horns
E6	Radio (except Japan)
E7	Radio (Japan)
F1	Front Wipe/Wash
F3	Rear Wipe/Wash
F8	Heated Rear Screen and Mirror Demisters
G4	Multi-Function Unit (MFU)
H1	Headlamps
H4	Side Lamps
H5	Stop Lamps
H6	Direction Indicator Lamps
H7	Reversing Lamps
H9	Rear Fog Guard Lamps
J1	Interior Lamps
J2	Cigar Lighter/Clock
K1	Blower Controls
K2	Compressor Controls
K5	Cooling Fans
L1	driver's side
L4	LH front corner of engine compartment
L6	Central Locking (except Japan)
L7a	Central Locking (Japan)
M3	Power mirrors
P1	Trailer Auxiliary Socket
T1	Theft Alarm System
Y1	Power Distribution
Y2	Fuse Details
Y5	Ground Distribution
Z4	Component Location Table
Z5	Component Location Views
Z6	Connector Views
Z8	Harness Routing
Z9	Index

Published by Land Rover  
Lode Lane, Solihull, West Midlands,  
B92 8NW, England

© Rover Group Limited 1997  
Publication Part No LJBEMENR95 (2nd Edition)



**CIRCUIT DIAGRAMS**

- Circuit diagrams are arranged so that current flow is from the top of the diagram (current source) to the bottom of the diagram (ground).
- Only those components that work together in the circuit are shown. If only part of a component is used in the circuit, then only that part of the component is shown.
- Remember:

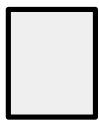

Entire component

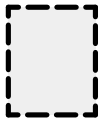

Part of a component

**TERMINAL NUMBER****DESIGNATION**

50	Battery voltage: Ignition Switch in position III
30	Battery voltage: supplied constantly
15	Battery voltage: Ignition Switch in position II or III
R	Battery voltage: Ignition Switch in positions I, II
31	Ground

See Introduction (i) for additional circuit diagram symbols.

**DIAGNOSIS**

- If the diagram is accompanied by text:
  - Read the Circuit Operation before proceeding with the electrical diagnosis.
  - Read the Troubleshooting Hints before performing the System Diagnosis.
  - Tests follow the System Diagnosis
  - When performing the System Diagnosis, be certain that all components disconnected in previous steps are reconnected unless otherwise directed.



Component is disconnected.  
Backprobe harness connector



Component is connected.  
Backprobe harness connector



Component is disconnected.  
Probe component



Component is disconnected.  
Probe harness connector



Probe in-line connector

## INTRODUCTION

This manual is intended for use by trained Land Rover technicians as an aid to diagnosing electrical concerns.

This manual is organized into sections, with most sections containing circuit diagrams. Each section has a unique alpha–numeric code that will normally remain the same from year to year. For example, the Headlights circuit is in Section H1, with the first page of the section numbered H1–1. The following pages of this section will be numbered H1–2, H1–3, H1–4, etc. The manual does not contain any information concerning removal, refit or overhaul of electrical components or harnesses. These details are contained in the Workshop Manual. The following information forms the basis of the troubleshooting routines:

- Circuit Diagrams
- System Diagnosis Flow Charts
- Component Location Table
- Component Locations Views

Additional information, such as Circuit Operation, is also contained in the manual to aid in your understanding of how the different circuits operate.

## DESCRIPTION OF MANUAL

### Circuit Operation And Diagram

The Circuit Operation information at the beginning of the section will give you an overview of how the circuit works.

The Circuit Diagrams should always be your starting point in using this Electrical Troubleshooting Manual. The diagram shows the electrical current paths when a circuit is operating properly. It is essential to understand how a circuit should work before trying to figure out why it doesn't. Diagrams are shown with the Ignition Switch in the OFF position and other switches in the OFF or 'at rest' position.

Notes are provided after certain switches to clarify switch positions. Abbreviations found in the notes are explained in the Abbreviation Table found in the SYMBOLS section of this chapter.

Circuit Diagrams (schematics) break the entire electrical system into individual circuits. Electrical

components that work together are shown together.

Each diagram is arranged so current flows from positive, at the top of the page, to ground, at the bottom of the page. The 'power' labels at the top of a fuse show when the Battery, Main Light Switch, or Ignition Switch supplies power to that fuse.

Wires that connect to another circuit are shown with an arrowhead pointing in the direction of current flow. The name of the circuit that shares the wiring is provided for reference.

Wire Colour charts are no longer provided on each circuit page. One chart is provided in the SYMBOLS section of this chapter.

'See Fuse Details' means there are more connections to other circuits that are not shown. All such shared circuits are shown on the Fuse Details diagrams. 'See Ground Distribution' means there are more shared ground circuits which are shown on the Ground Distribution diagrams.



No attempt is made on the diagrams to represent components and wiring as they physically appear on the car. For example, a long length of wire is treated no differently in a diagram from one which is only a few centimeters long. The number of cavities for each connector is listed in the Component Location Table rather than illustrated. Similarly, switches and other components are shown as simply as possible, with regard to function only.

### Power Distribution

The Power Distribution diagrams are found in Section Y1. These diagrams show how voltage is supplied from the positive Battery terminal to the various circuits in the vehicle.

The individual Circuit Diagrams begin with a fuse or the Ignition Switch. Power Distribution shows the wiring from the Battery to the Fuse Boxes, the Ignition Switch, the Main Lighting Switch, and any circuit fuses not located in a Fuse Box.

### Fuse Details

The Fuse Details diagrams are found in Section Y2. These diagrams show all the wiring between each fuse in the Fuse Boxes and the components connected to the output of the fuse. The Fuse Details diagrams are extremely helpful in locating a short circuit that causes a fuse to blow. These diagrams also aid in troubleshooting an inoperative circuit by showing a second circuit using the same fuse. If the second circuit works, then the fuse and certain wires of the inoperative circuit are good.

### Ground Distribution

The Ground Distribution diagrams are found in Section Y5. These diagrams show which components share each ground point. This information can often be a time-saver when troubleshooting a poor ground.

For example, if the Fuel Pump does not run, you may suspect an open in its circuit to ground. However, if the Number Plate Lamps work, and they share the same ground point as the Fuel Pump, you know that the ground and the wire up to the common splice are good. You have learned this just by inspecting the diagram and knowing the vehicle's symptoms.

### Connector Views

Connector Views are provided in section Z6. All connectors with 2 terminals or more will be shown. Pin-out tables with the appropriate wire colours will also be shown.

### Component Location Table

A Component Location Table can be found in Section Z4. Except for the location of obvious components like the Left Headlight, the table lists the location of every component, connector and ground point depicted in the Circuit Diagrams. The table also gives references to Component Location Views located in Section Z5 and cross references to Workshop Manual remove and refit procedure sections. The number of cavities in each connector and the connector colour is also listed. Wires may not be used in all connector cavities.

## TROUBLESHOOTING TECHNIQUE

The following five-step troubleshooting procedure is recommended.

### (1) Verify the Problem

Check the operation of the circuit to be sure you understand the problem. Do not begin disassembly or testing until you have narrowed down the possible causes.

### (2) Analyze the Circuit Diagram (schematic)

Analyze the diagram. Check circuits that share the wiring with the problem circuit. The names of shared circuits are often given on each Circuit Diagram to aid troubleshooting. Shared power and ground circuits can be found in the Power and Ground Distribution sections. Try to operate the shared circuits. If these circuits work, then the shared wiring is OK. The cause must be within the wiring used only by the problem circuit. If several circuits fail at the same time, chances are the power (fuse) or ground circuit is faulty.

### (3) Find the Cause

- Narrow down the possible causes.
- Before you replace a component, check power, signal, and ground wires at the component harness connector.

### (4) Repair the Problem

Once the specific problem is identified, make the repair. Be sure to use the correct tools and safe procedures.

### (5) Check the Repair

Check the operation of the repaired circuit in all modes to make sure you fixed the entire problem. If the problem was a blown fuse, be sure to test all of the circuits on that fuse. Make sure no new problems are present.

## TEST EQUIPMENT

Where applicable, Land Rover recommended testers should be used.

### Voltmeter and Test Light

Use a voltmeter or test light to check for voltage. While a test light shows whether or not voltage is present, a voltmeter indicates how much voltage there is.

**CAUTION:** A number of circuits include solid-state devices. Voltages in these circuits should be tested only with a 10-megohm or higher impedance digital multimeter. Never use a test light on circuits that contain solid-state devices. Damage to the device may result.

On circuits without solid-state devices, a test light may be used to check for voltage. A test light is made up of a 12-volt bulb with a pair of leads attached. After grounding one lead, touch the other lead to various points along the circuit where voltage should be present. The bulb will come on if the voltage at the point being tested is greater than 5 volts.

### Self-powered Test Light and Ohmmeter

Use a self-powered test light or ohmmeter to check for continuity. The ohmmeter shows how much resistance there is between two points along a circuit. Low resistance means good continuity.

**CAUTION:** Never use a self-powered test light on circuits that contain solid-state devices. Damage to these devices may result.

Diodes and solid-state devices in a circuit can make an ohmmeter give a false reading. To find out if a component is affecting a measurement, take one reading, reverse the leads, and take a second reading. If the readings differ, the component is affecting the measurement.

Circuits that contain solid-state devices should only be tested with a 10-megohm or higher impedance digital multimeter.

A self-powered test light consists of a light bulb, Battery and two leads. If the leads are touched together, the bulb will go on.

A self-powered test light is only used on an unpowered circuit. First, disconnect the battery or remove the fuse that feeds the circuit you are working on. Select two points along the circuit through which there should be continuity. Connect one lead of the self-powered test light to each point. If there is continuity, the test light's circuit will be completed and the bulb will go on.

#### **Fused Jumper Wire**

Use a fused jumper wire to bypass an open circuit. A fuse jumper wire is made up of an in-line fuse holder connected to a set of test leads. Never use a jumper wire across any load. This direct battery short will blow the fuse.

The following symbol represents a fused jumper:

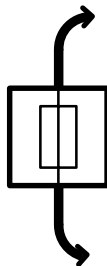

## SYMBOLS

The abbreviations and symbols explained here are used throughout the manual; it is necessary to know what they mean in order to use the diagrams effectively.

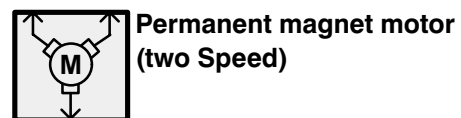
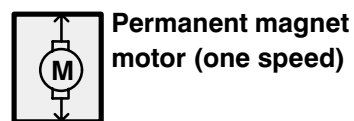
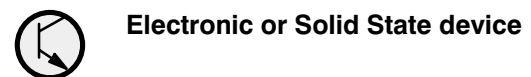
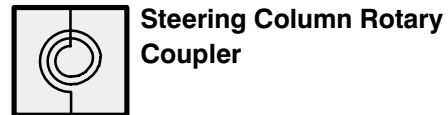
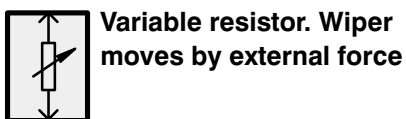
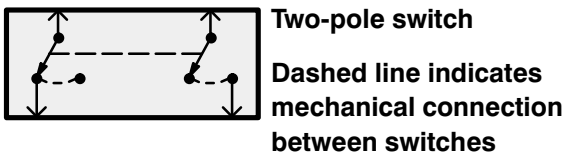
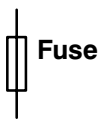
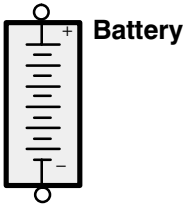

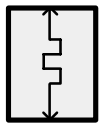

Heating Element

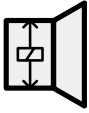

Loudspeaker or horn

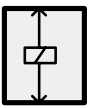

Coil

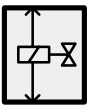

Solenoid



Relay

Switch is drawn into the closed position when current flows through coil

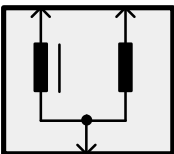

Ignition Coil

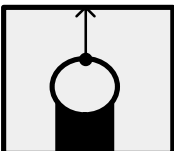

Steering Column  
Horn Brush/  
Slip Ring



Antenna

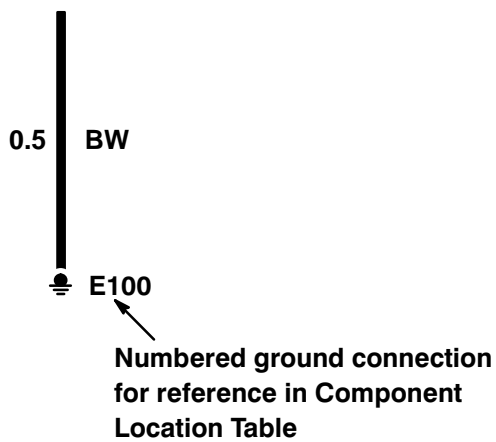
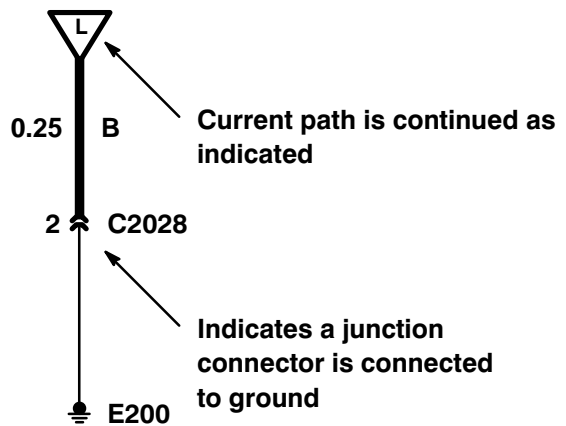
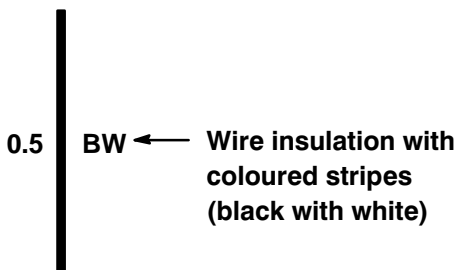
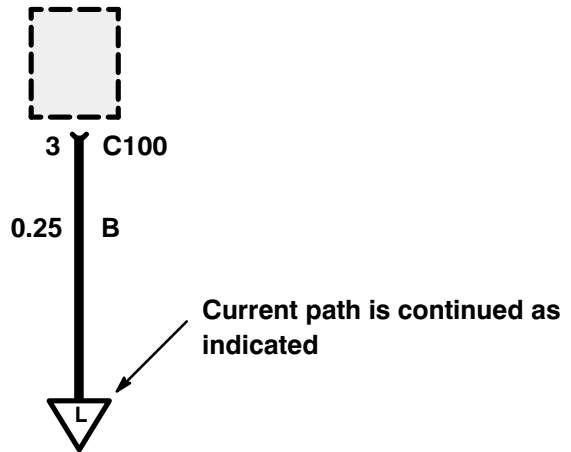
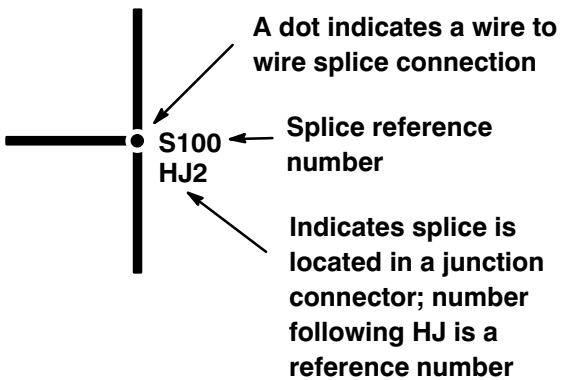
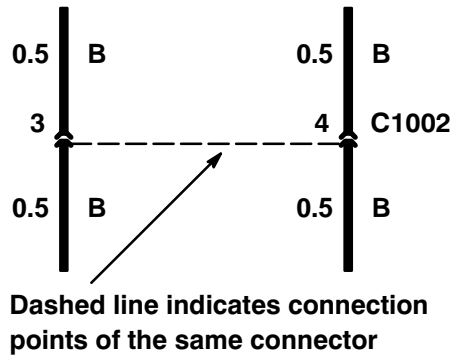
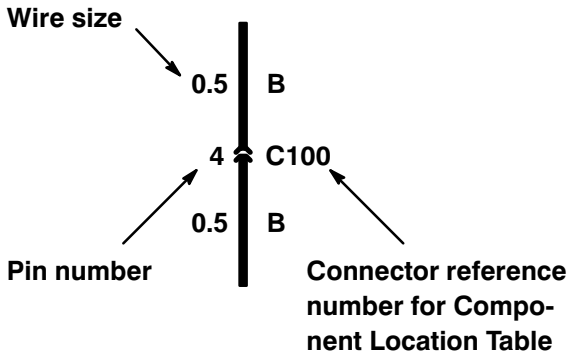

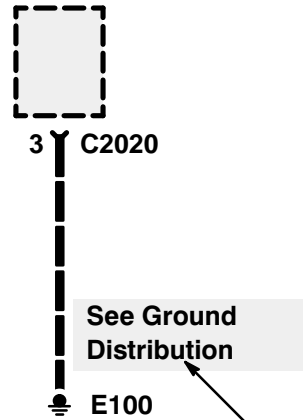
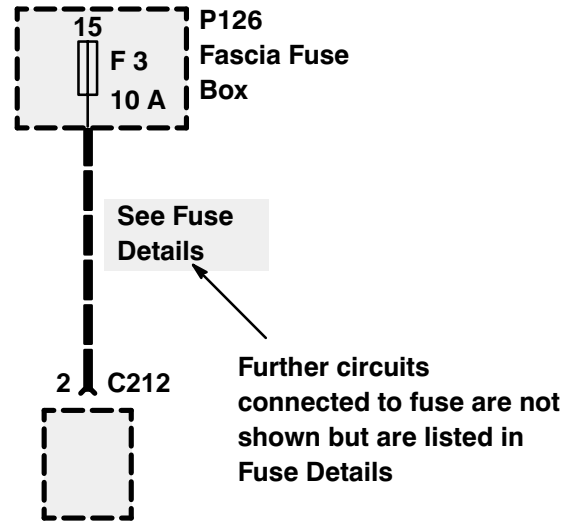
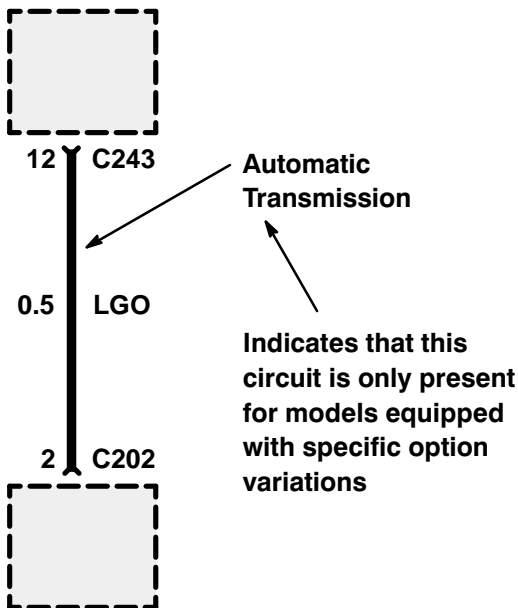
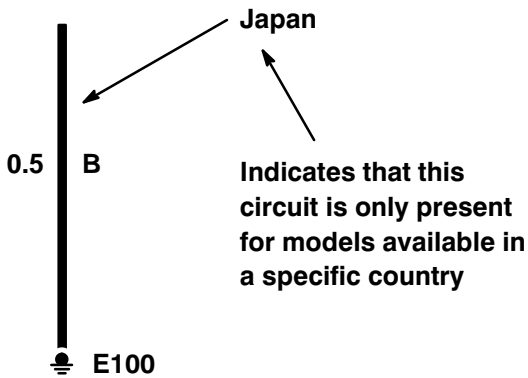
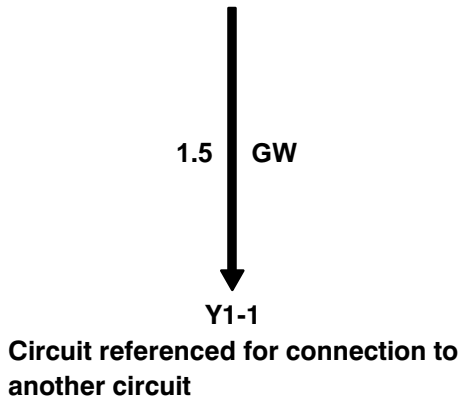

Further circuits connected at ground are not shown but are listed under Ground Distribution

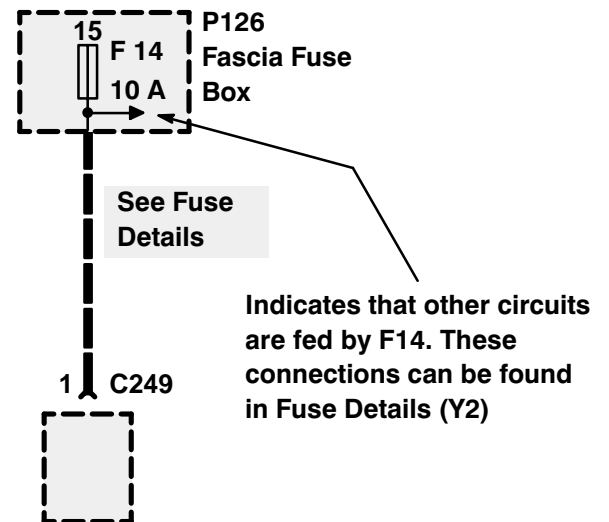

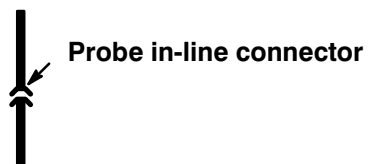
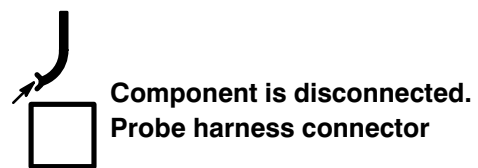
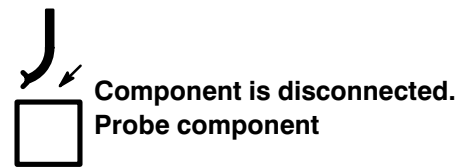
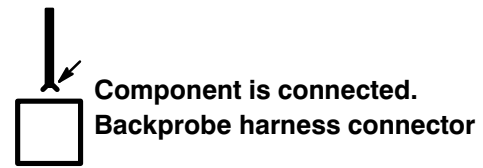
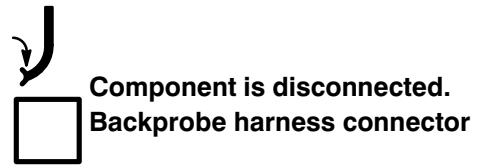
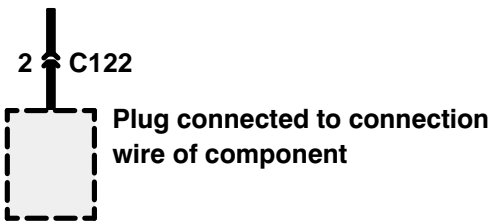
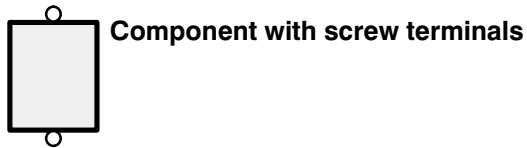
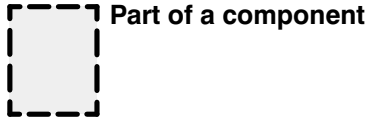





### Definition of Vehicle Component Codes

All components are identified by a letter followed by an arbitrary number assigned to the component. The letter assigned to the component indicates the type of component.

<b>B</b>	<b>Bulbs, Heated Screens, Mirror Demisters, Cigar Lighters, and Heated Washer Jets</b>
<b>K</b>	<b>Relays, Solenoids, Speakers, and Resistors</b>
<b>M</b>	<b>Motors</b>
<b>P</b>	<b>Fuse Boxes and Fusible Links</b>
<b>X</b>	<b>Switches and Sensors</b>
<b>Z</b>	<b>Electronic Control Units, Modules, Shields, Diodes, and Capacitors</b>

### Wire Colours

All wires are identified by letters which indicate a certain colour. Wire colour and size will only be shown once if it does not change throughout the circuit. The following chart explains the wire colour abbreviations.

#### Wire Colour Chart

<b>B - Black</b>	<b>P - Purple</b>
<b>G - Green</b>	<b>R - Red</b>
<b>K - Pink</b>	<b>S - Grey</b>
<b>L - Light</b>	<b>U - Blue</b>
<b>N - Brown</b>	<b>W - White</b>
<b>O - Orange</b>	<b>Y - Yellow</b>

**Circuit Qualifiers**

Certain abbreviations are used throughout the Electrical Troubleshooting Manual as circuit qualifiers. The following list explains all abbreviations used as qualifiers in the Circuit Diagrams.

<b>ABS</b>	<b>Anti lock Braking System</b>
<b>LHD</b>	<b>Left Hand Drive</b>
<b>RHD</b>	<b>Right Hand Drive</b>
<b>LWB</b>	<b>Long Wheel Base</b>
<b>SWB</b>	<b>Short Wheel Base</b>
<b>NAS</b>	<b>North American Countries</b>
<b>MFI-V8</b>	<b>Multiport Fuel Injection (MFI-V8)</b>
<b>MFI-T16</b>	<b>Multiport Fuel Injection (MFI-T16)</b>
<b>300 Tdi</b>	<b>Tdi Diesel</b>
<b>300 Tdi with EGR</b>	<b>Tdi Diesel with Exhaust Gas Recirculation (EGR)</b>
<b>300 Tdi without EGR</b>	<b>Tdi Diesel without Exhaust Gas Recirculation (EGR)</b>
<b>300 Tdi with EDC</b>	<b>Tdi Diesel with Electronic Diesel Control (EDC)</b>
<b>300 Tdi without EDC</b>	<b>Tdi Diesel without Electronic Diesel Control (EDC)</b>

**Switch Positions**

Certain abbreviations are used throughout the Electrical Troubleshooting Manual as Switch Position notes. The following list explains all abbreviations used as Switch Position notes in the Circuit Diagrams.

<b>&lt; 100°</b>	<b>Less than 100°</b>
<b>&gt; 100°</b>	<b>More than 100°</b>

Connectors, Grounds, and Splices are identified by a letter followed by a number. Connectors are identified by C, grounds by E, and splices by S. Some splices are contained in junction connectors. These splices are identified by the prefix "HJ" below the splice's reference number. The number assigned to the connector, ground, or splice corresponds to its location in the vehicle.

#### Connector, Ground, and Splice Identification by Location

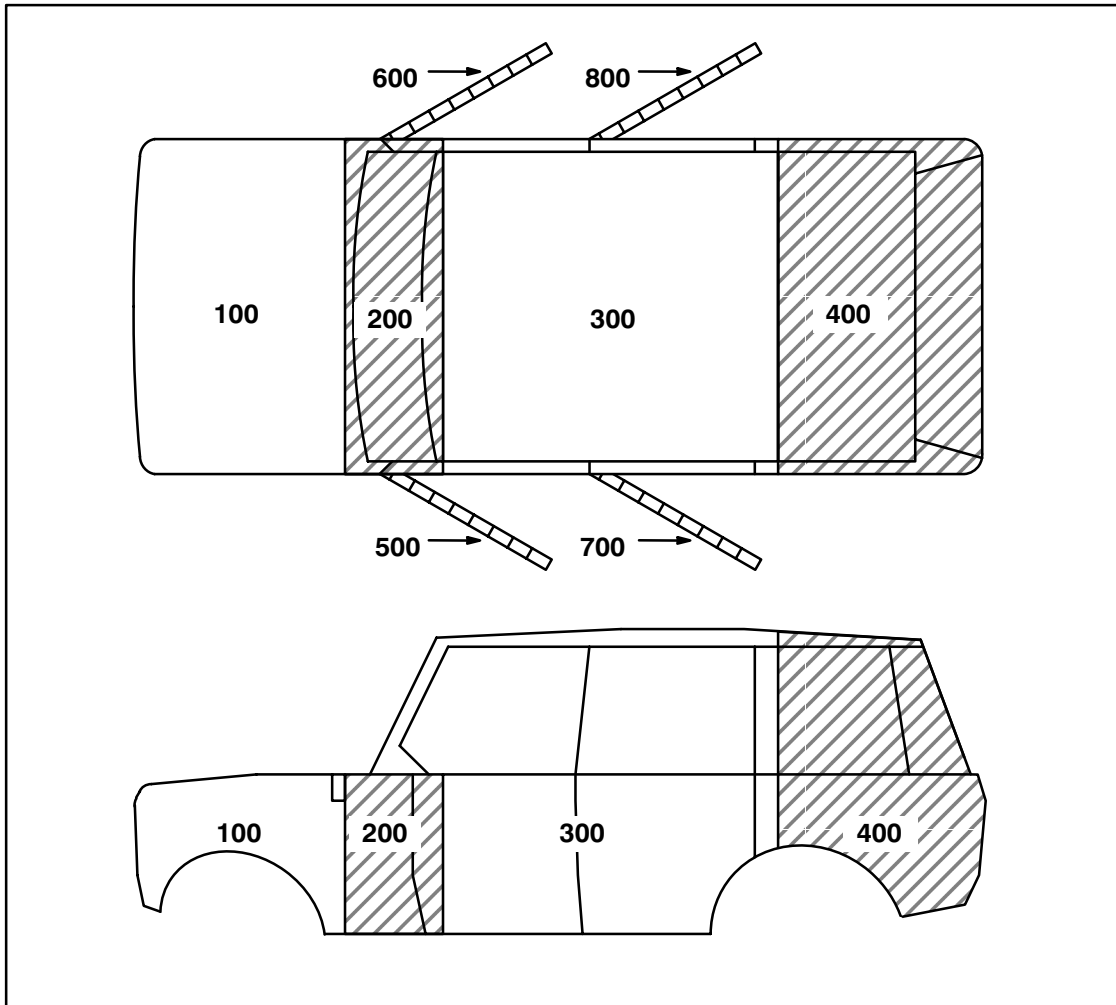

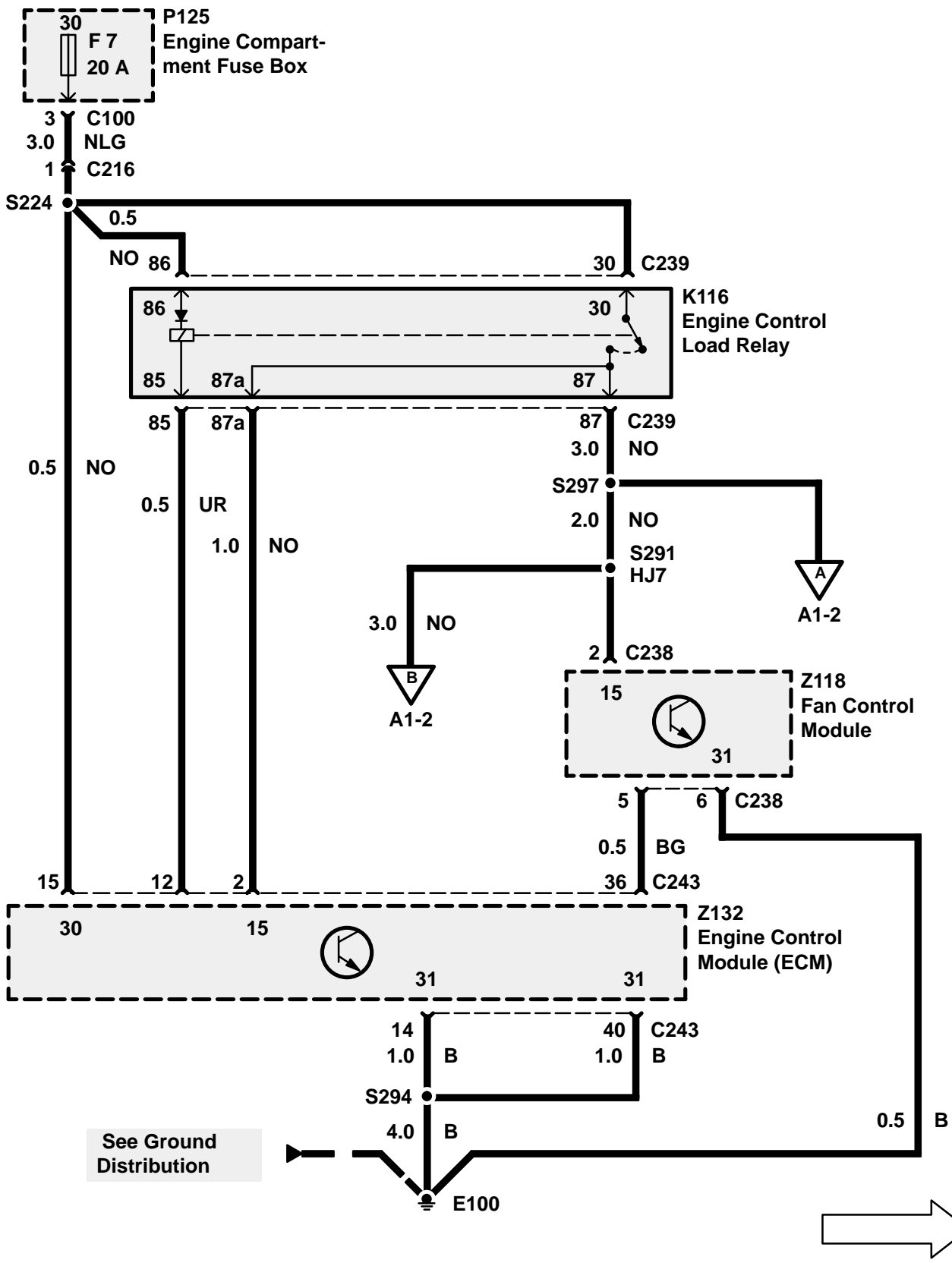

# A1 ETM

## DISCOVERY

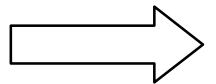
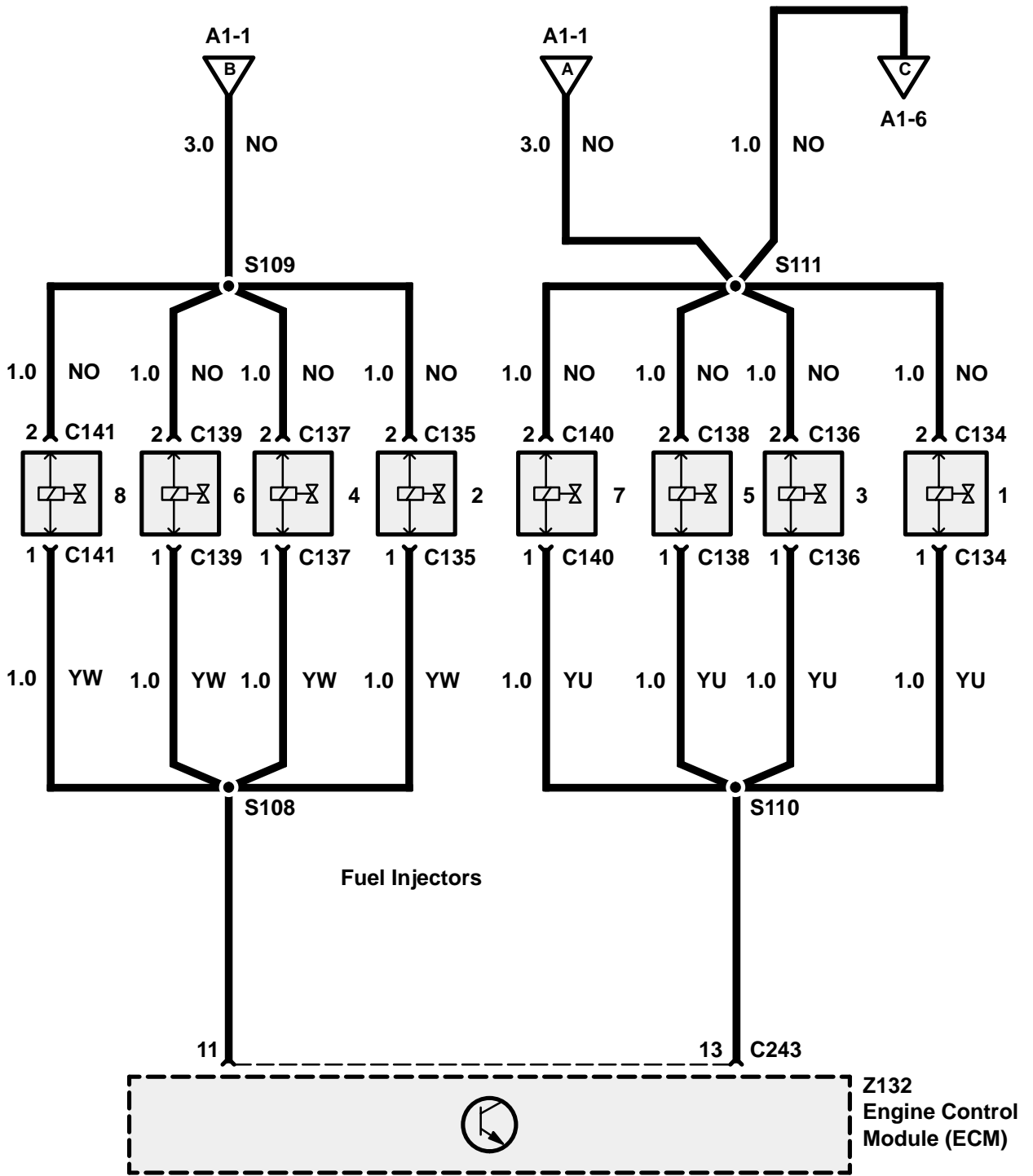



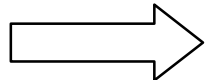
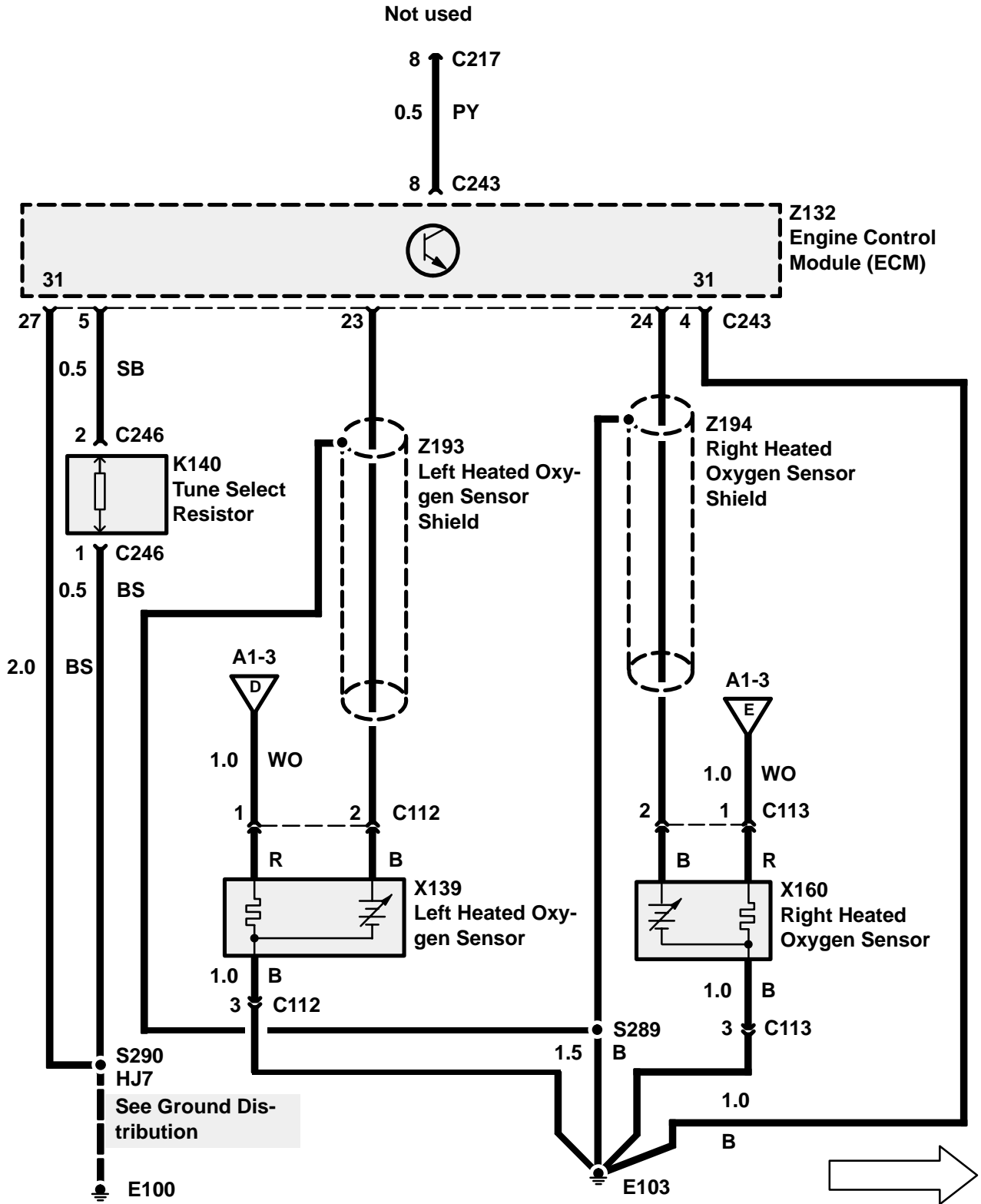



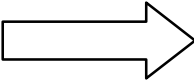
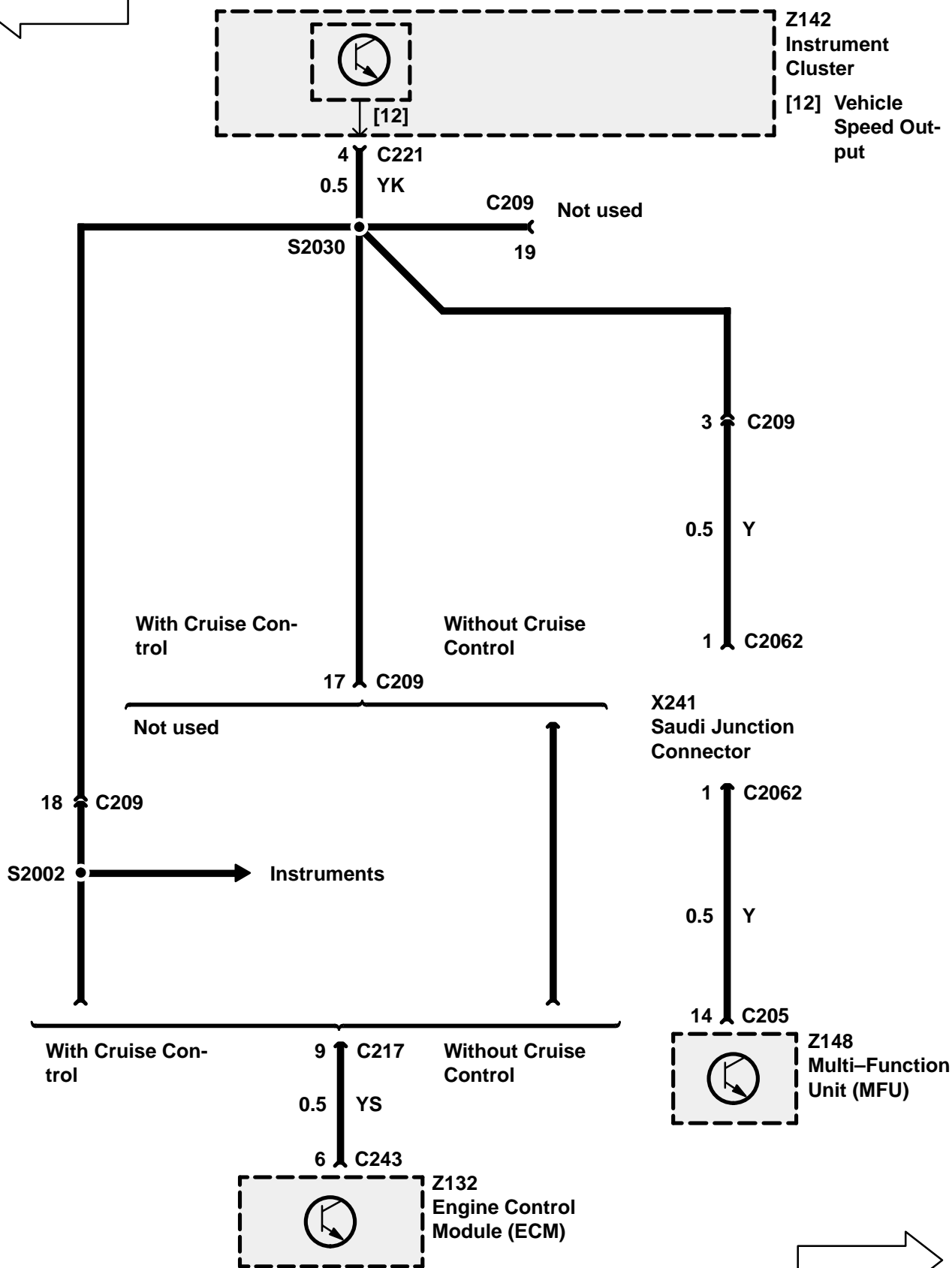
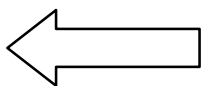

# A1 ETM

## DISCOVERY

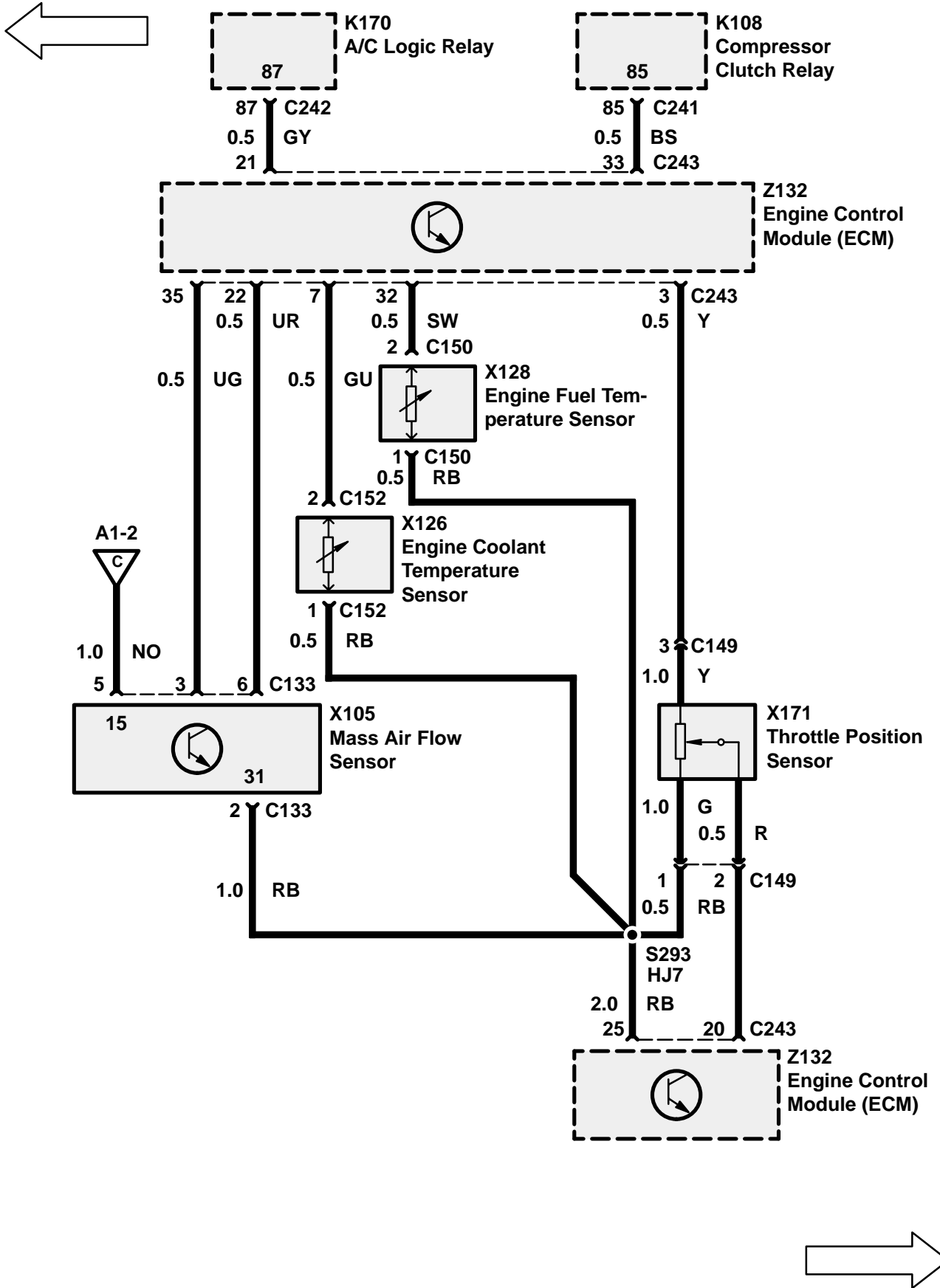

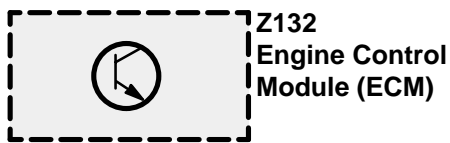
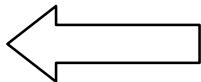

34 C243

0.5 OB

10 C217



0.5 BY

9 C105

0.5 YB

Automatic Transmission

Manual Transmission

\* For vehicles not equipped with Theft Alarm or Central Locking, a blank wire is used to short pins 1 and 2 of C274.

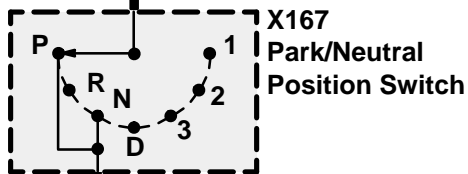
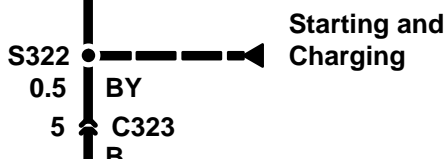

0.5 BG

4 C323

0.5 BO

11 C105

Except Japan

Japan

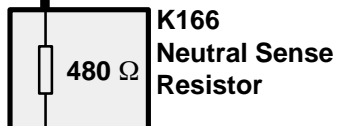

See Ground Distribution

0.5 B

S343

5 C105

S204 HJ5

E201

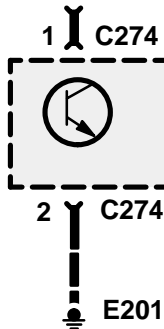

Z163 \* Theft Alarm Unit

See Ground Distribution

0.5 B

S2025

See Ground Distribution

E201

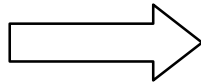

# A1 ETM

## DISCOVERY

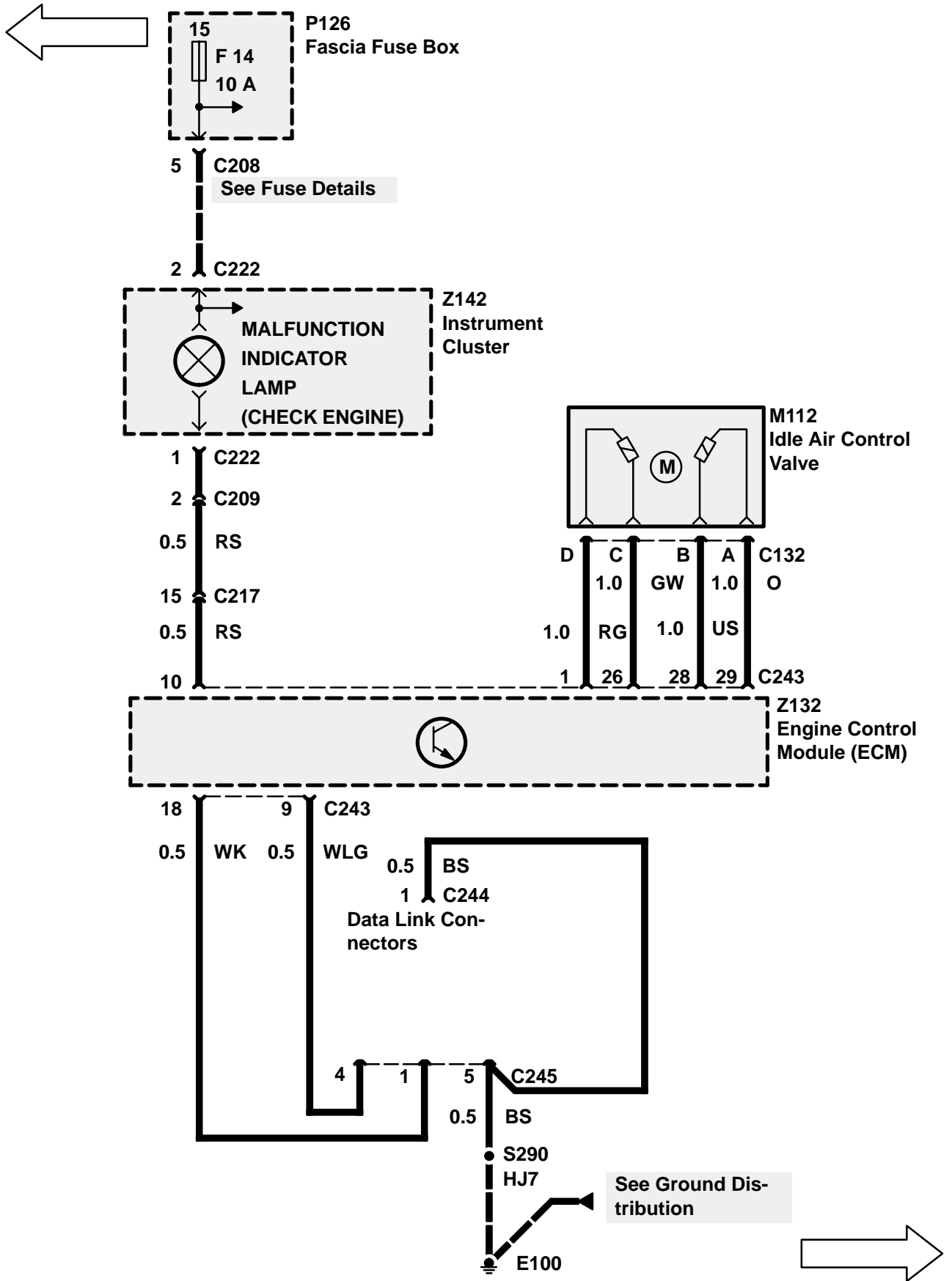

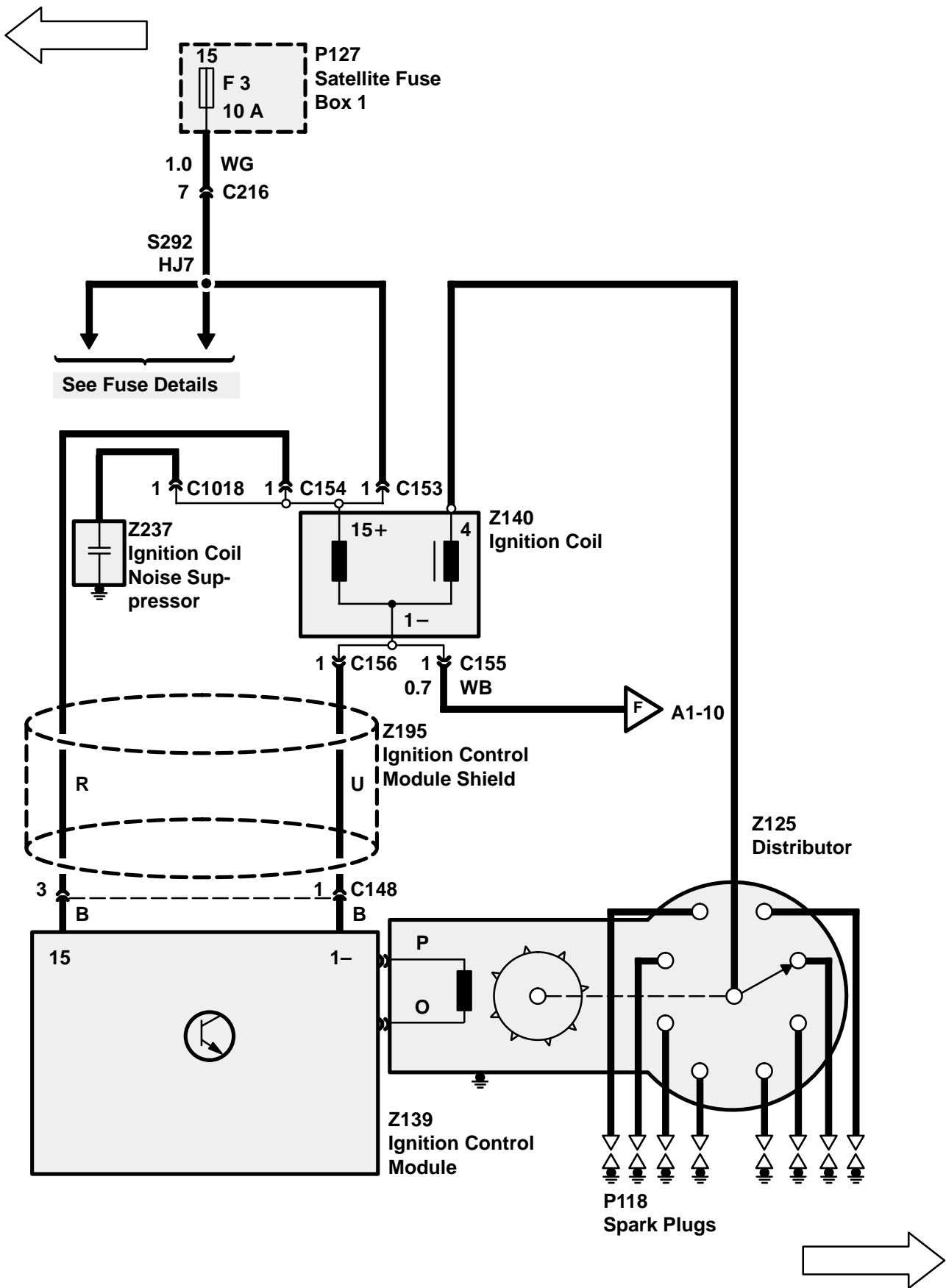

**A1 ETM**

Multiport Fuel Injection (MFI-V8)

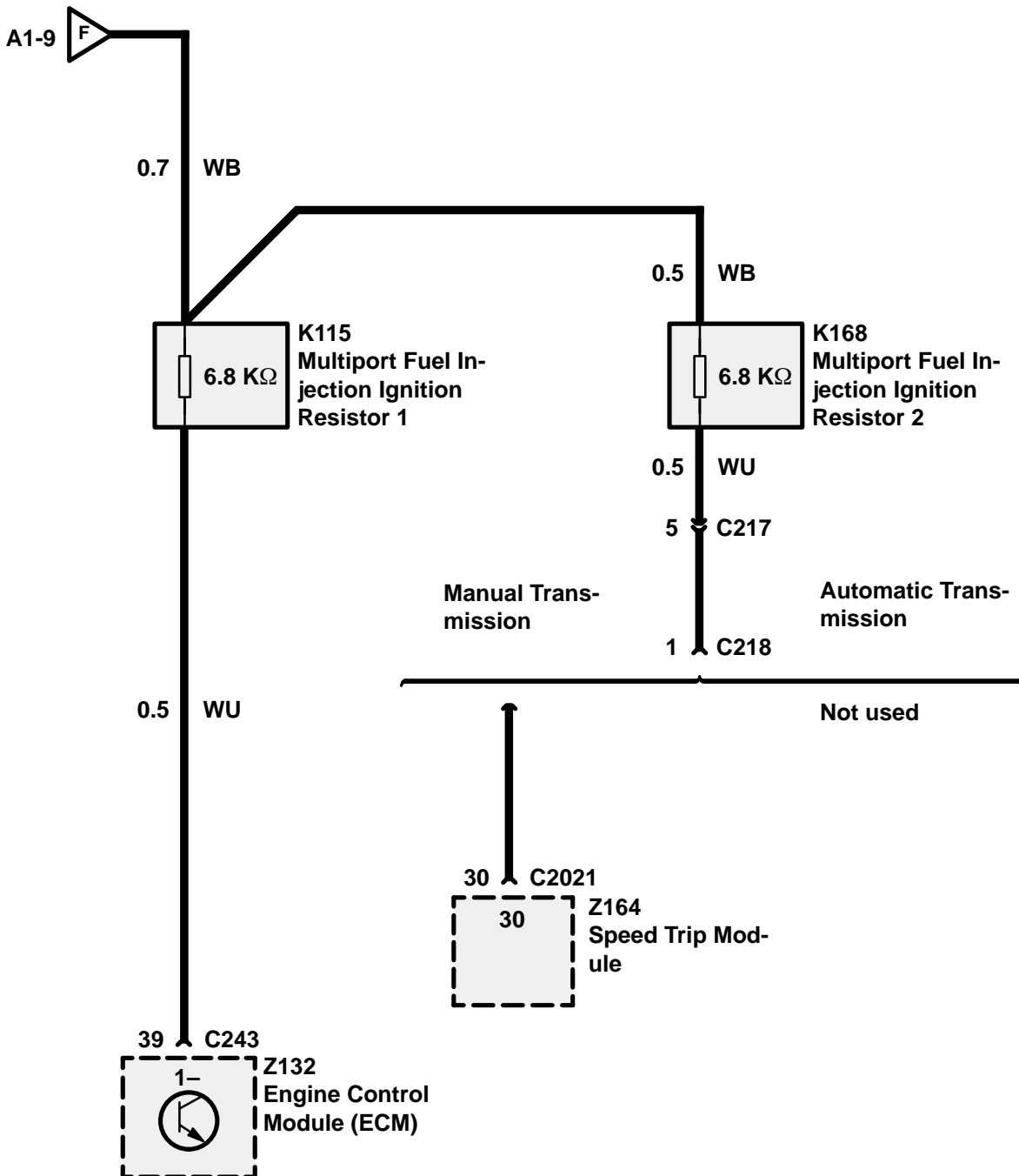
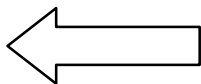

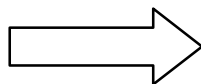
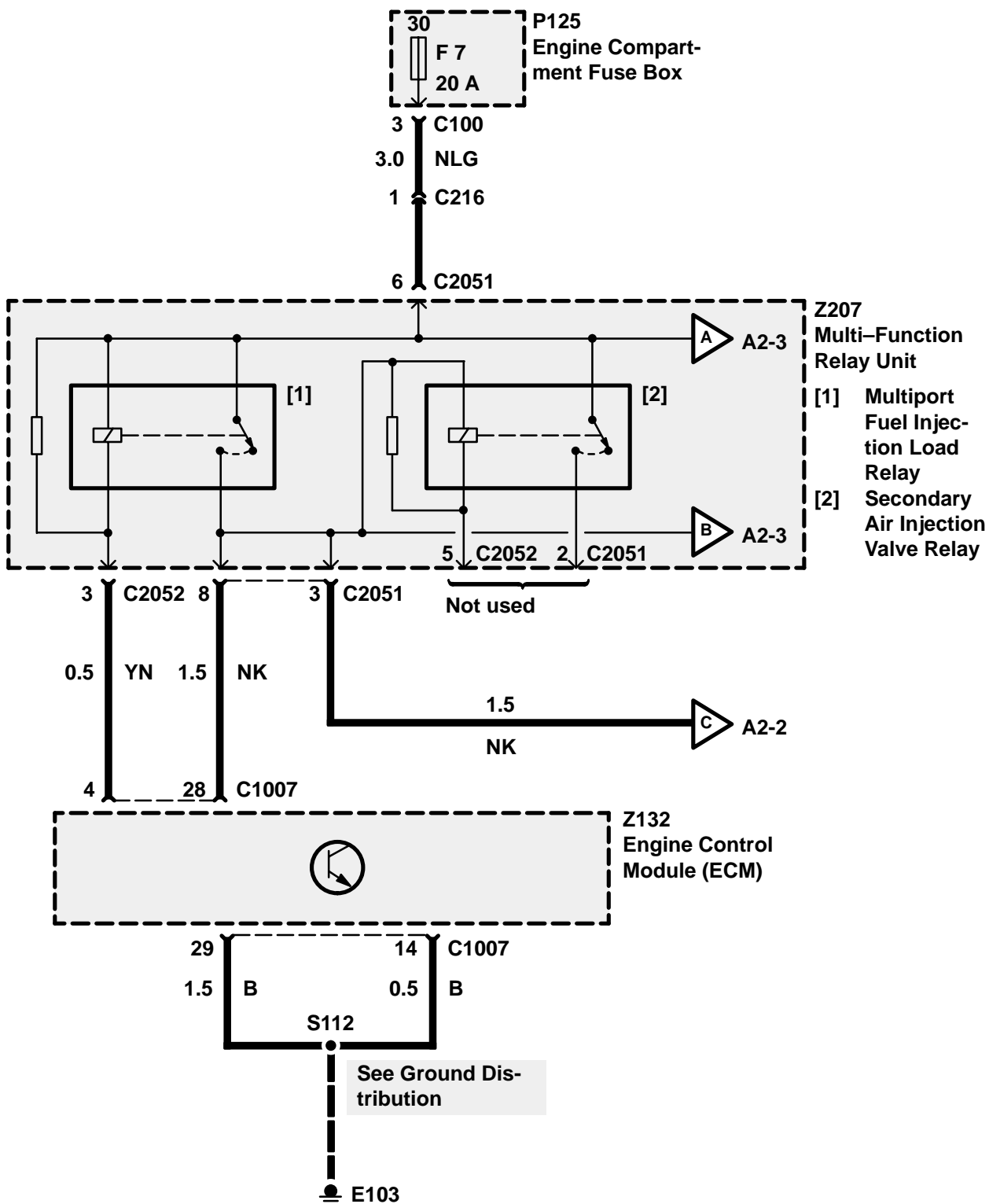

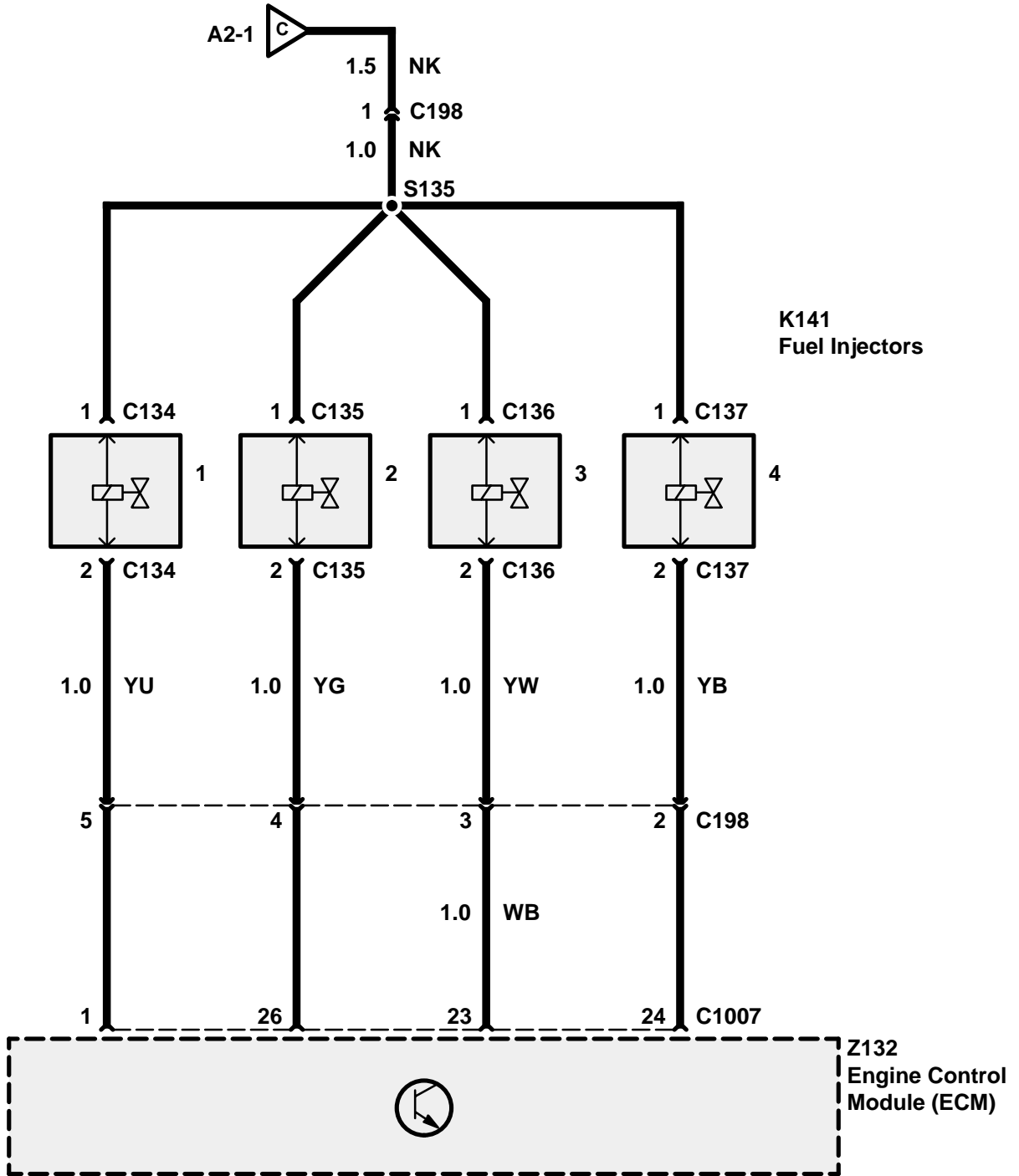
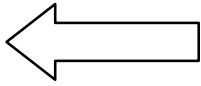

K141 Fuel Injectors

Z132 Engine Control Module (ECM)

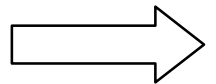



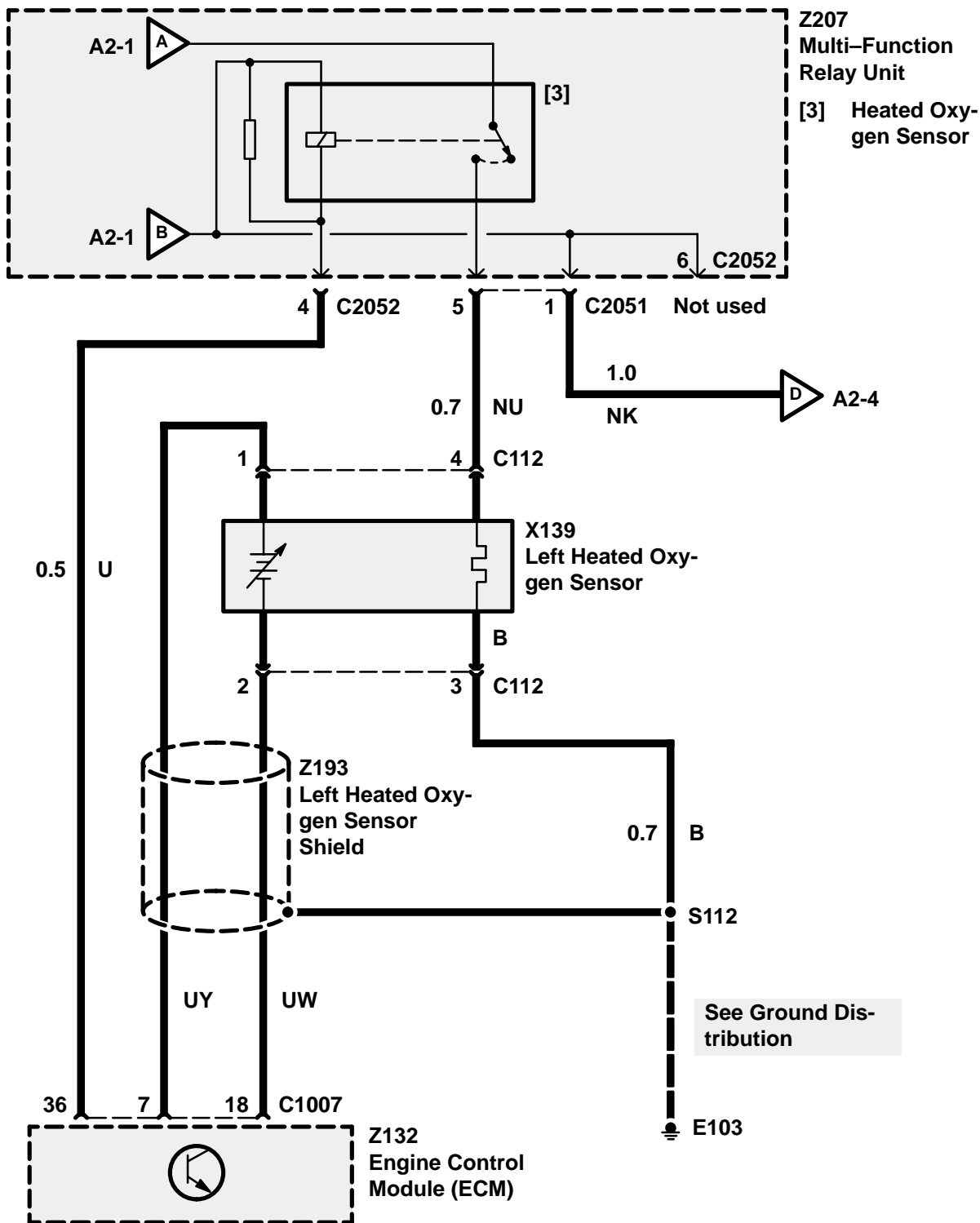
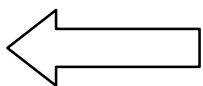

See Ground Distribution

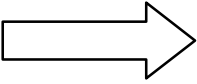

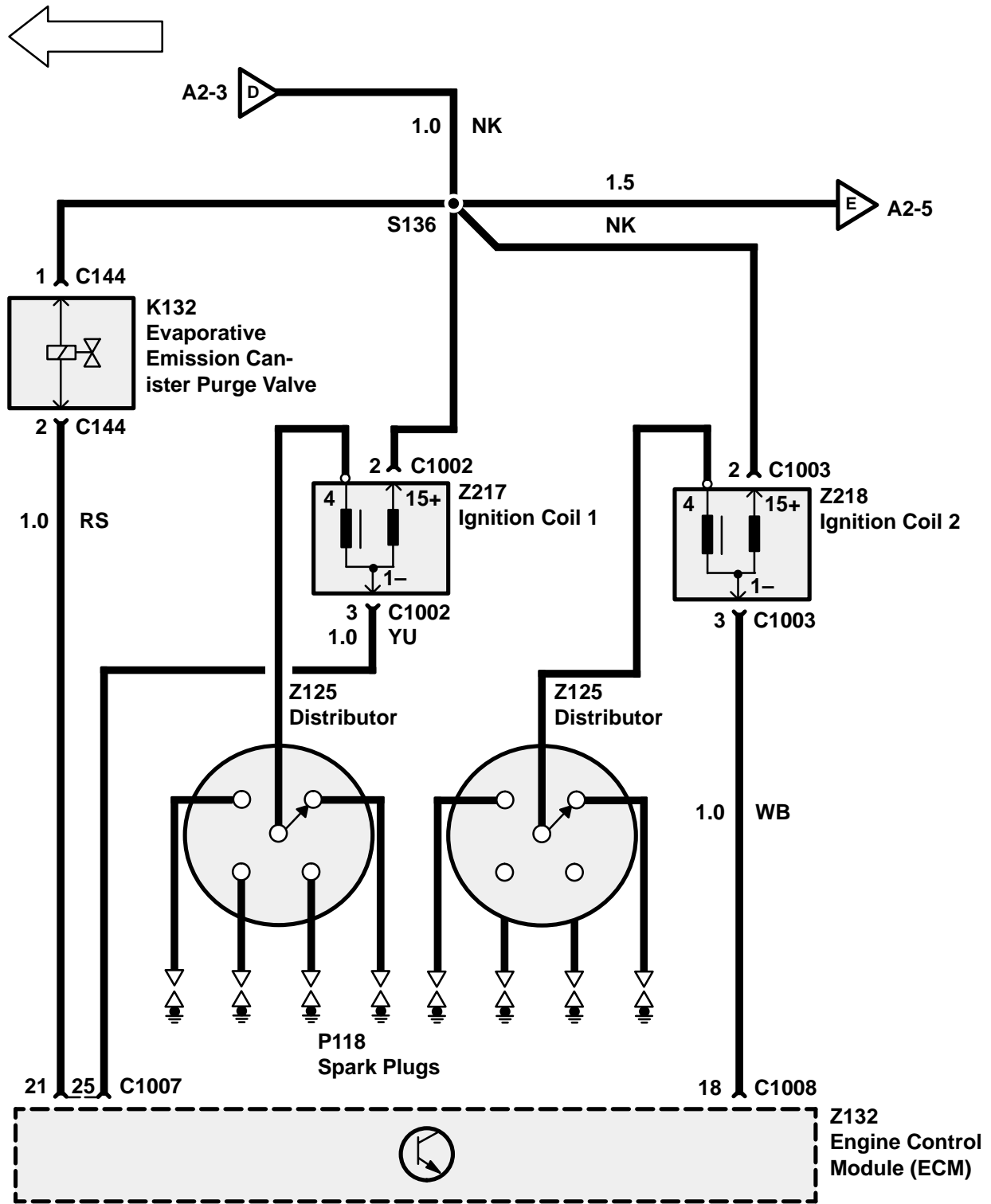

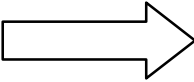
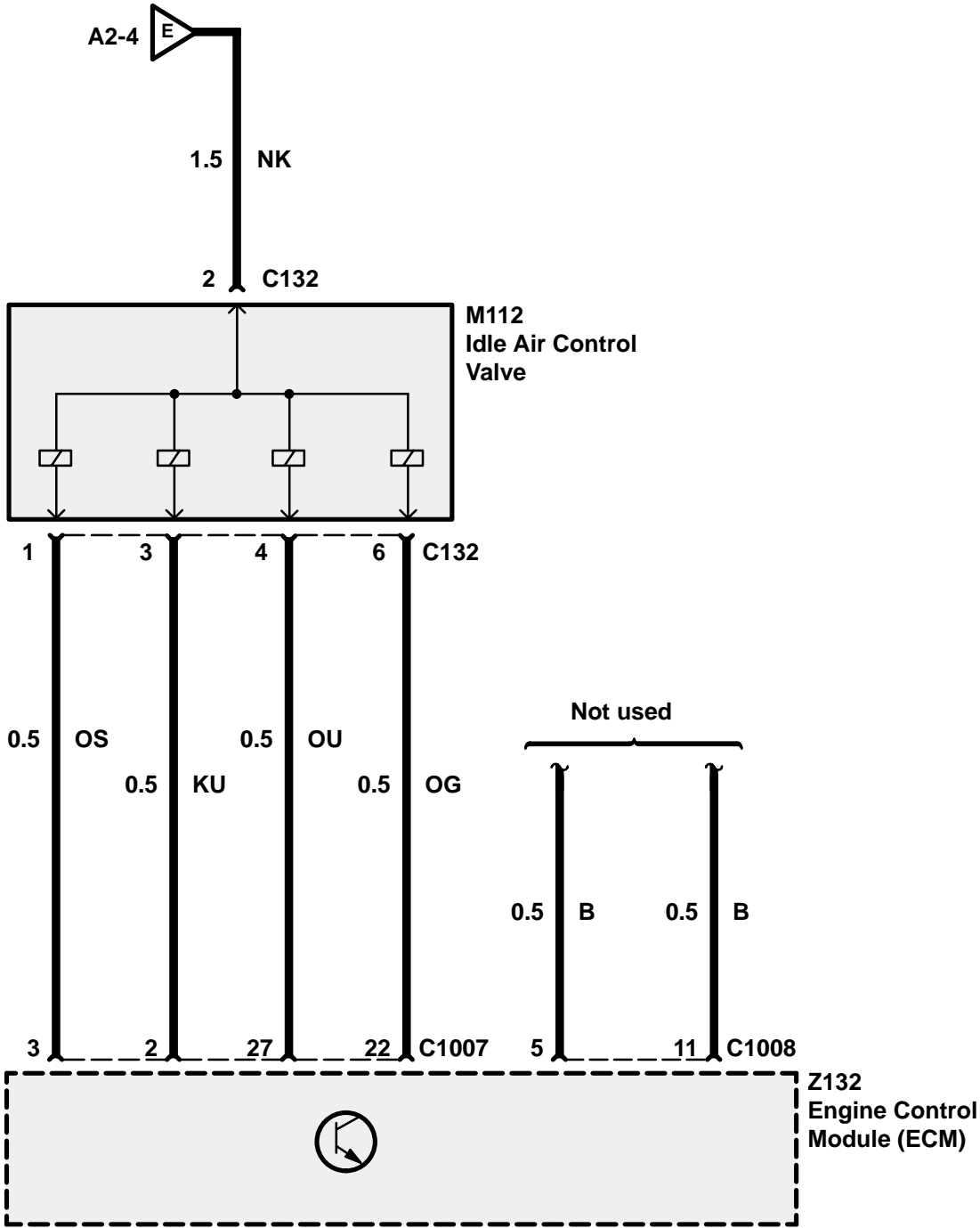
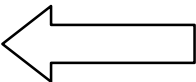

# A2 ETM

## DISCOVERY

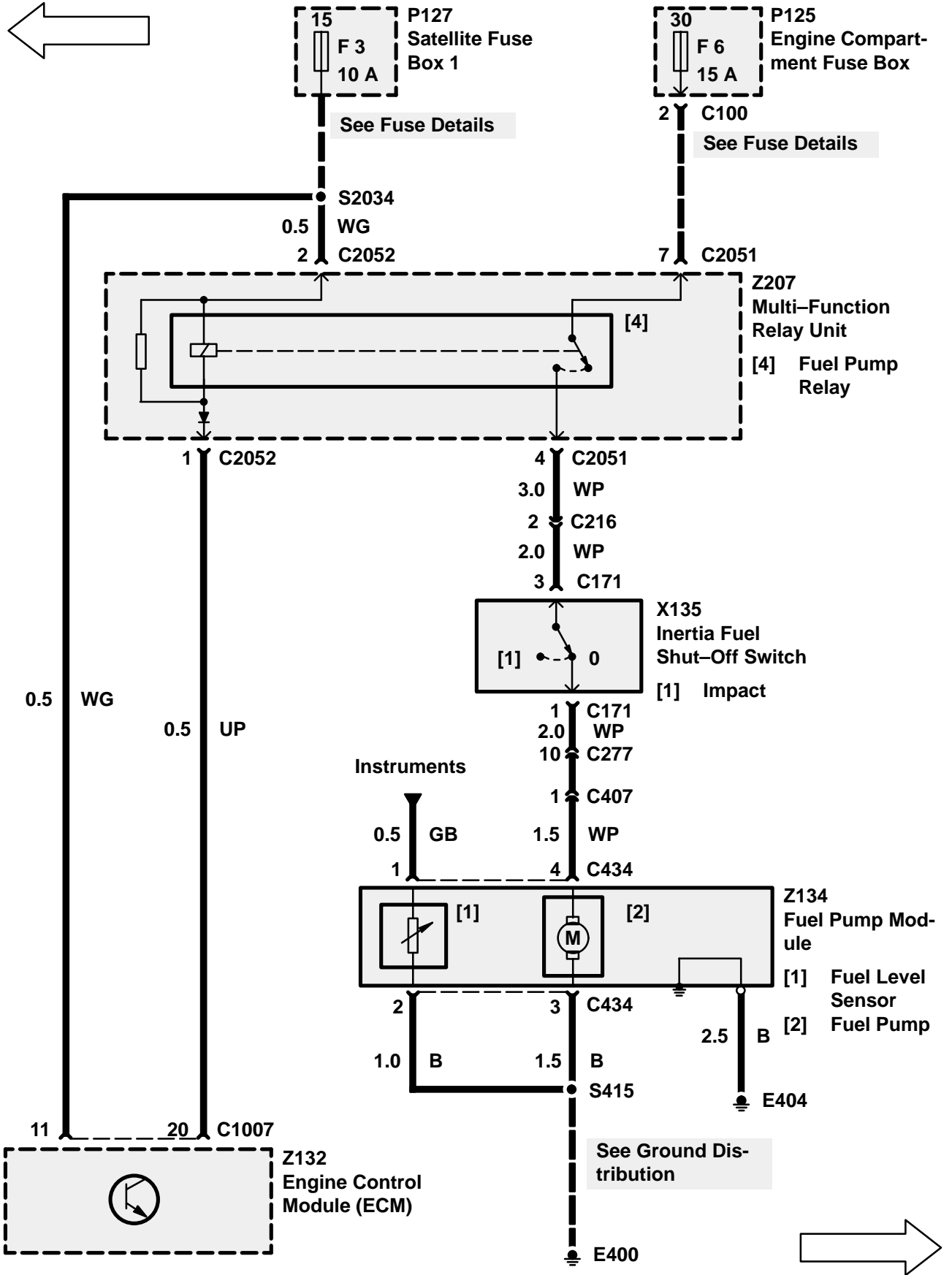

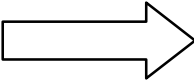
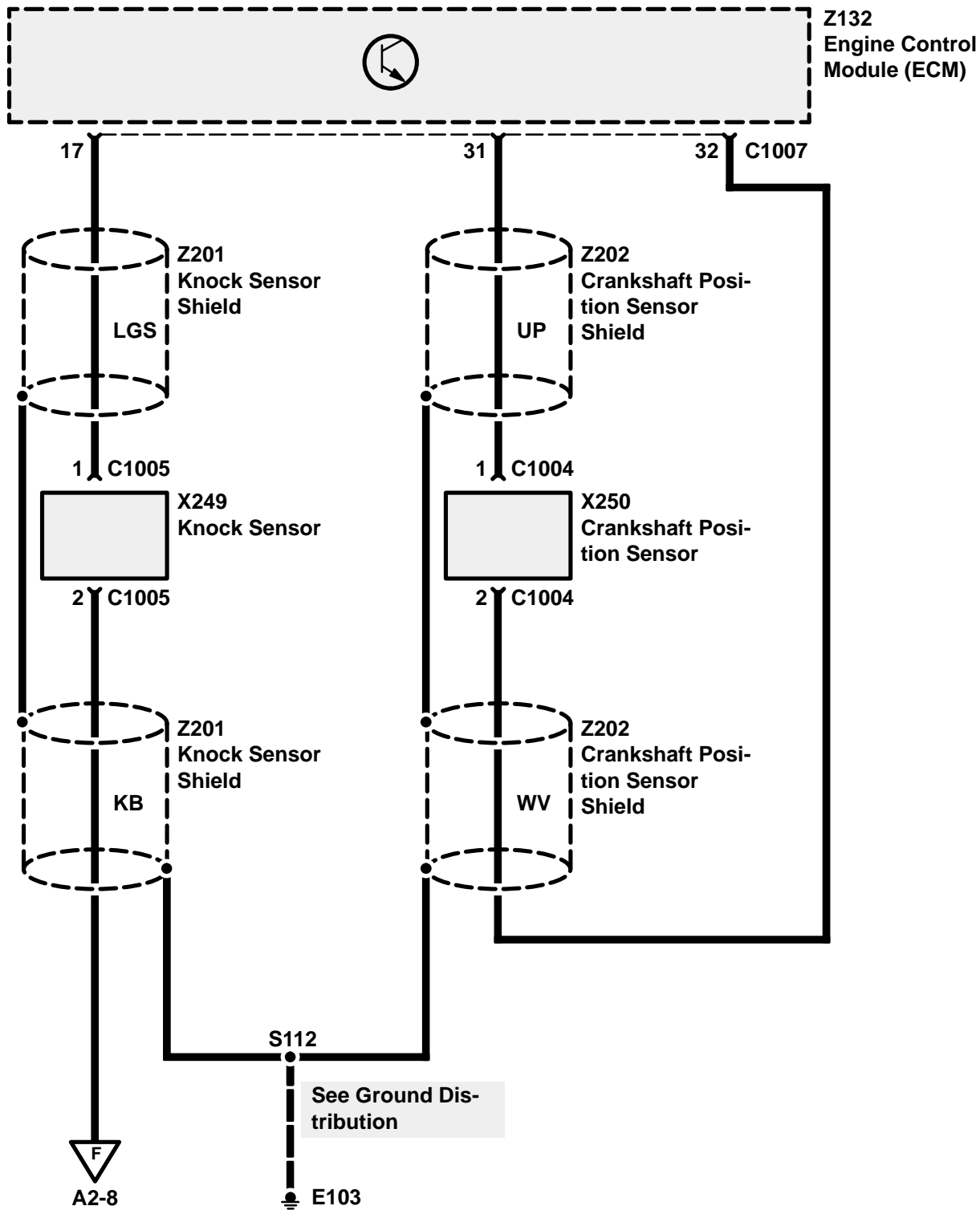
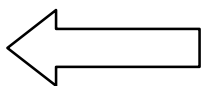

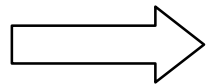
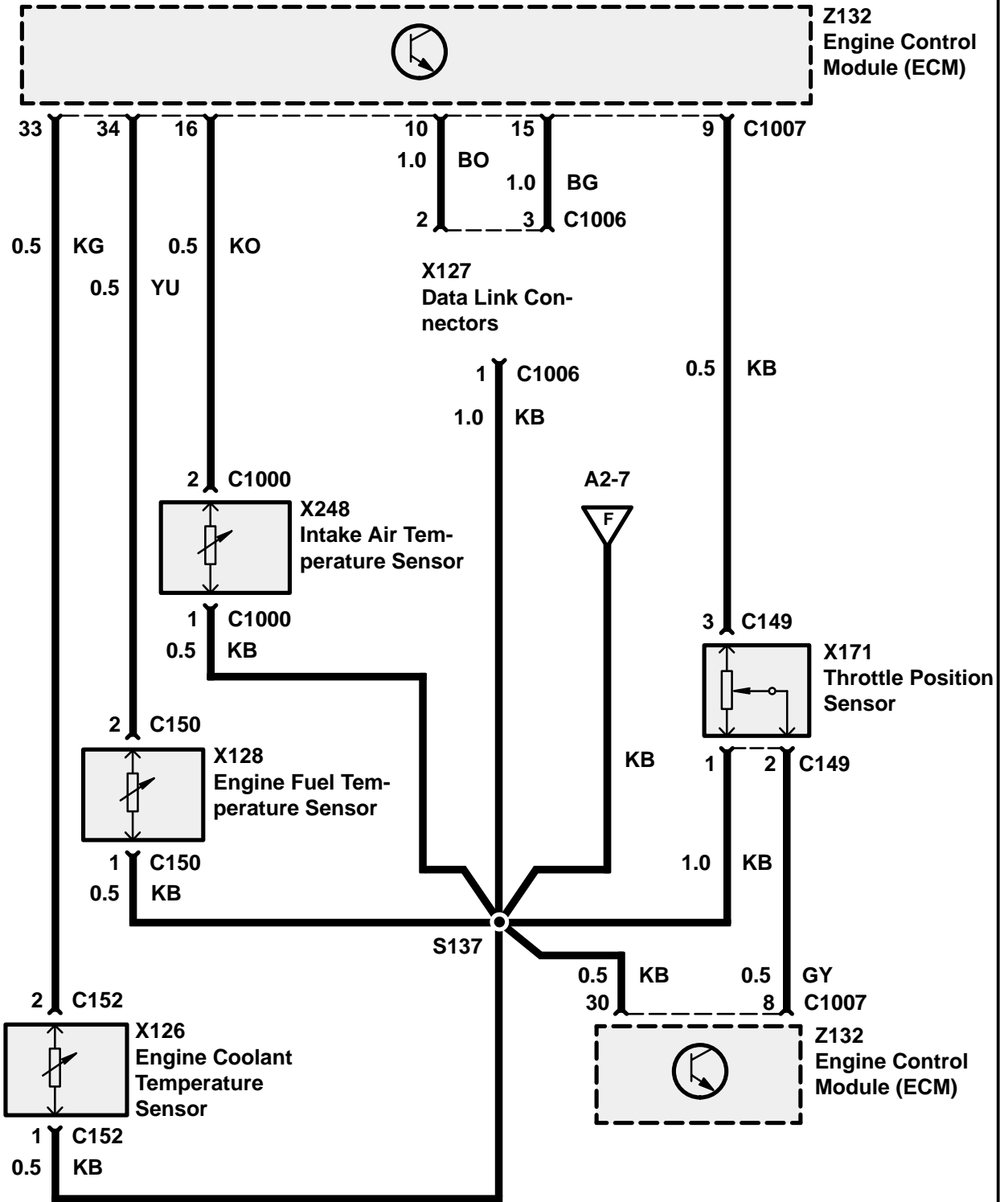
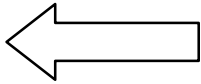

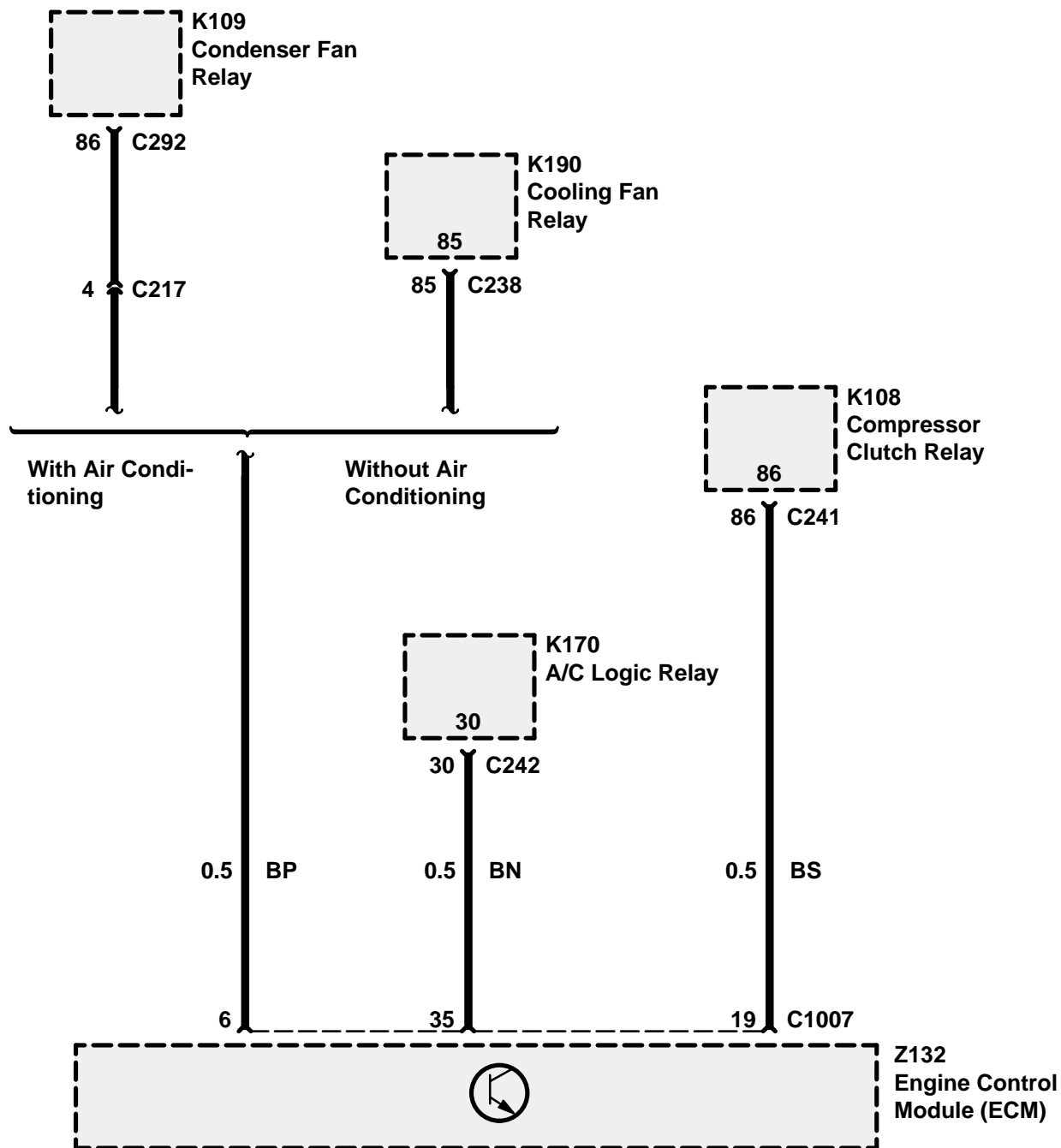
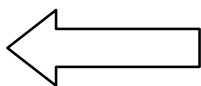

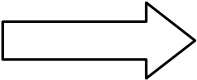
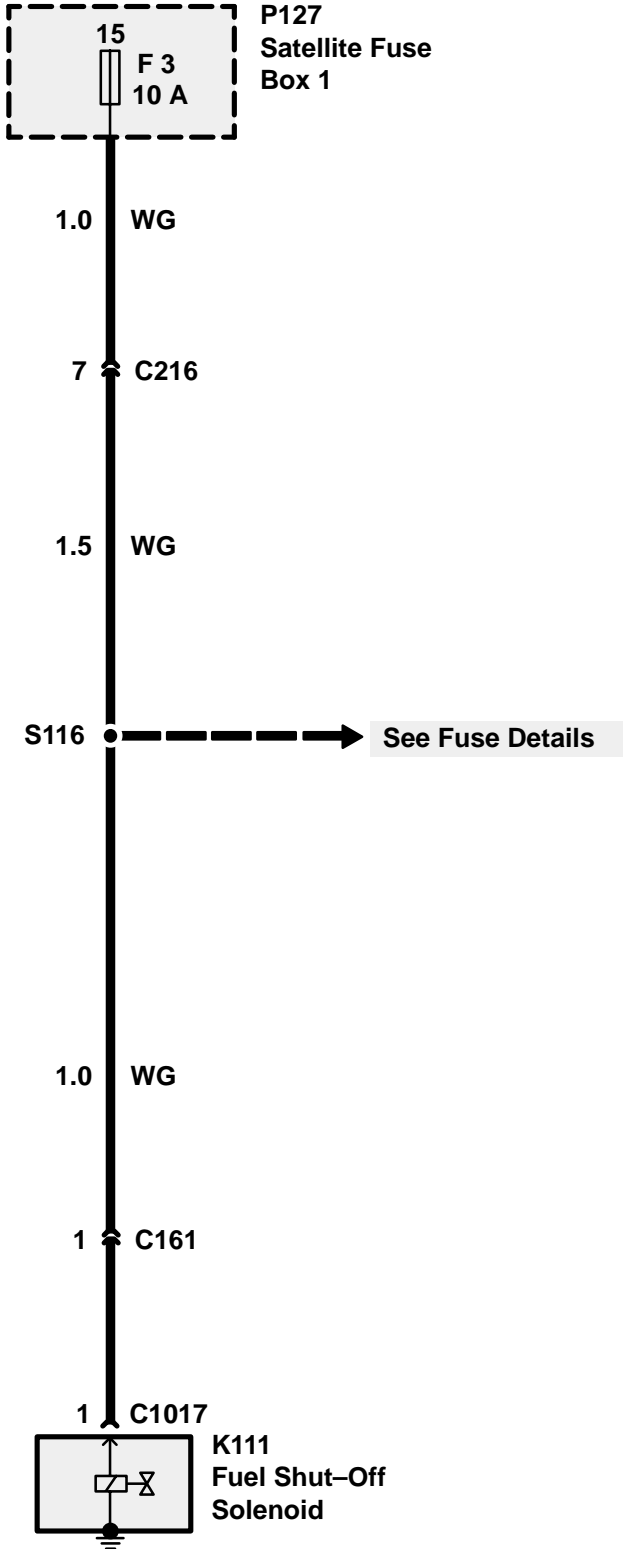



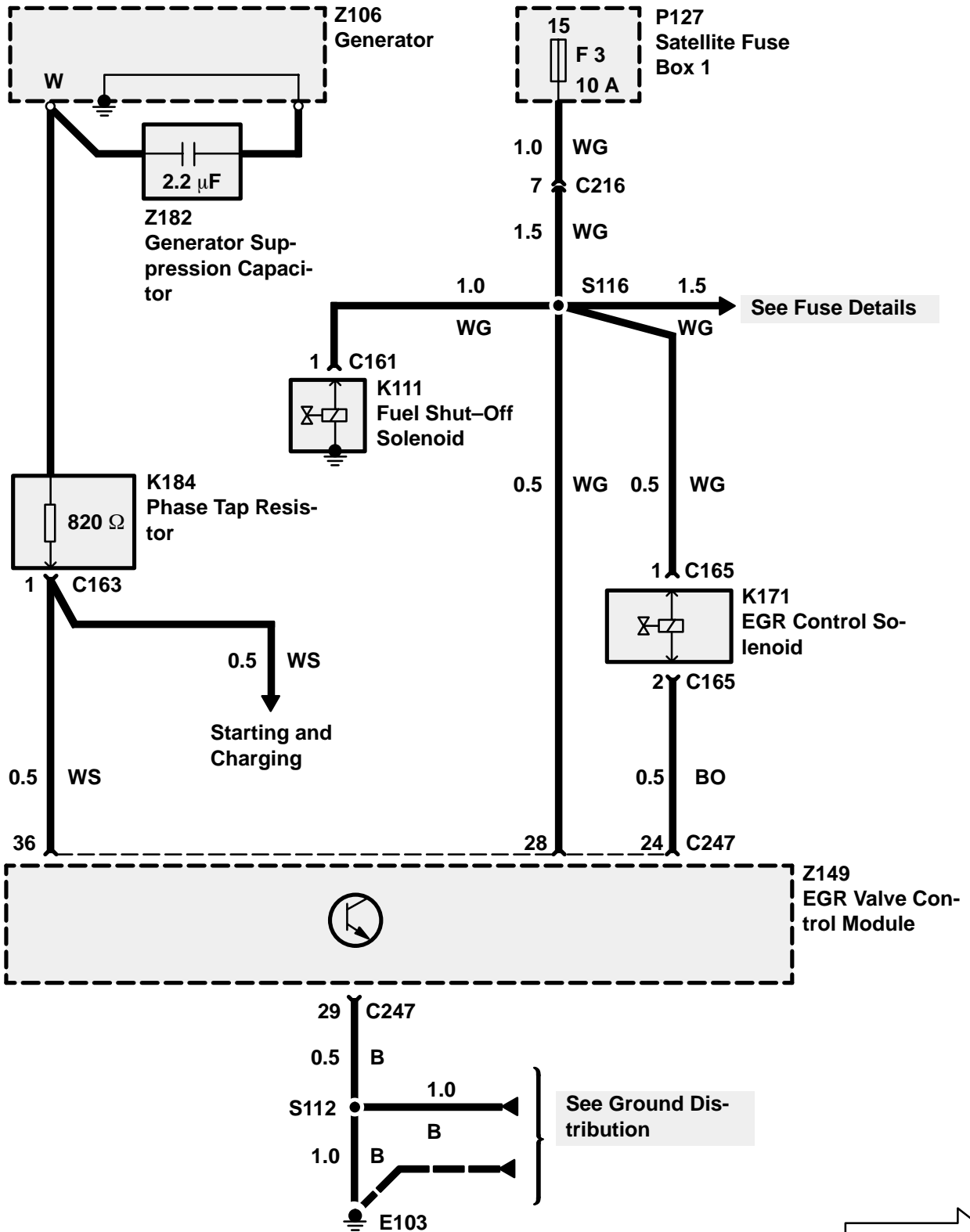
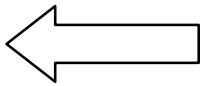

See Fuse Details

See Ground Distribution

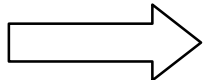

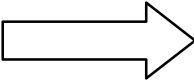
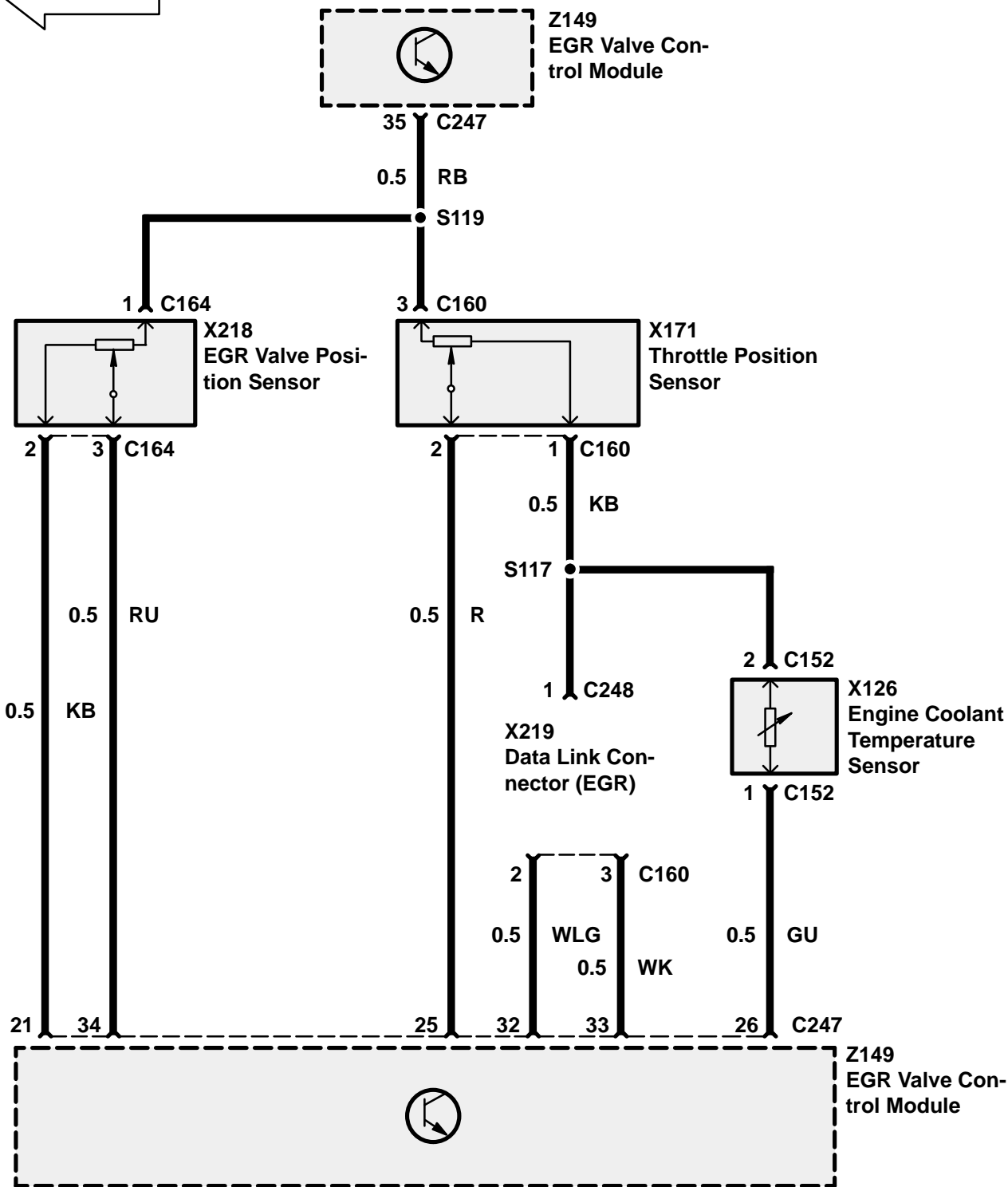
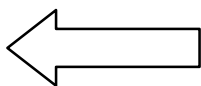



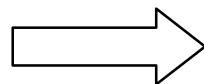
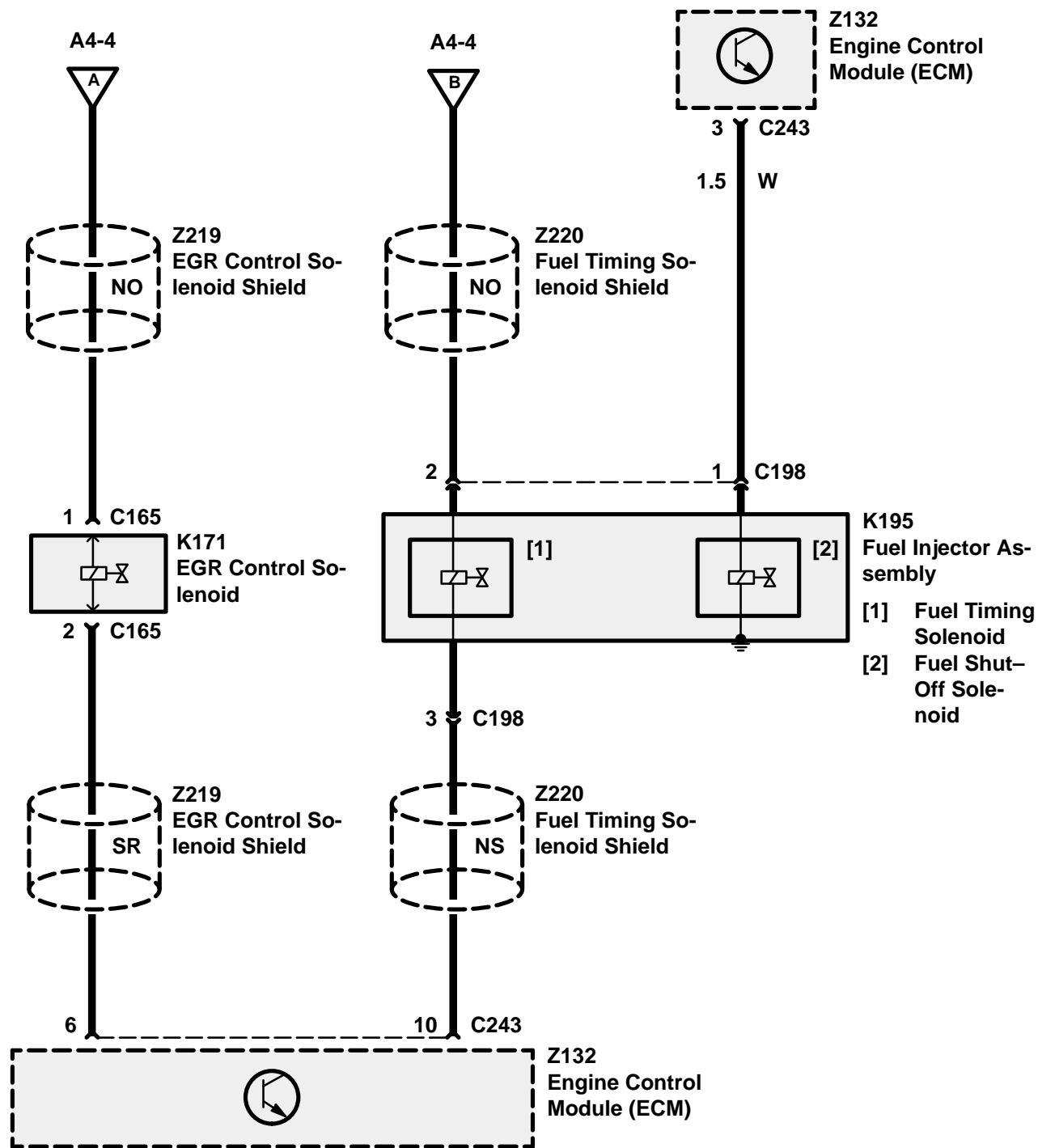
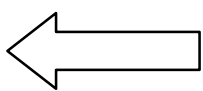



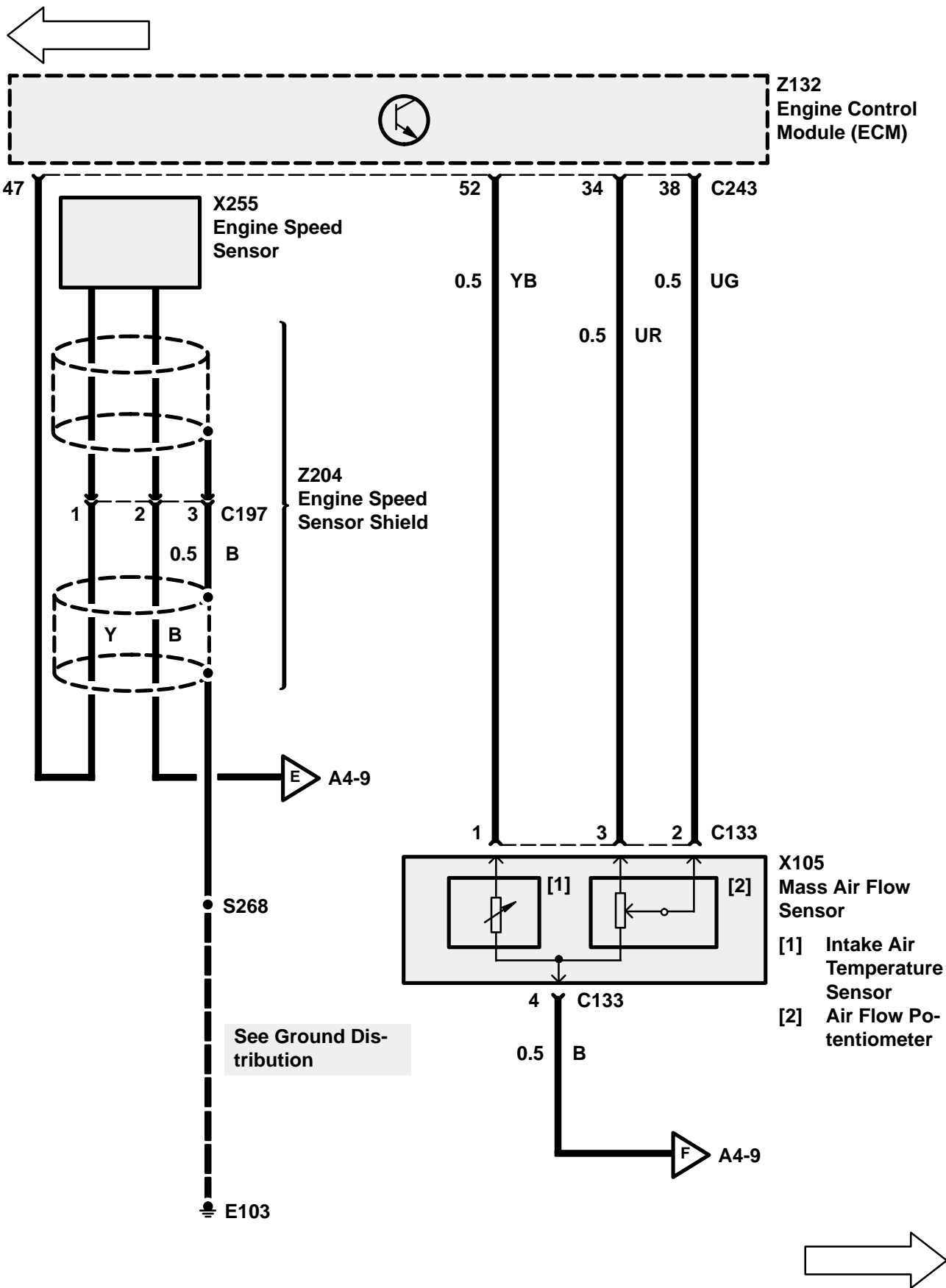

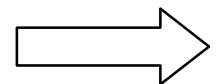
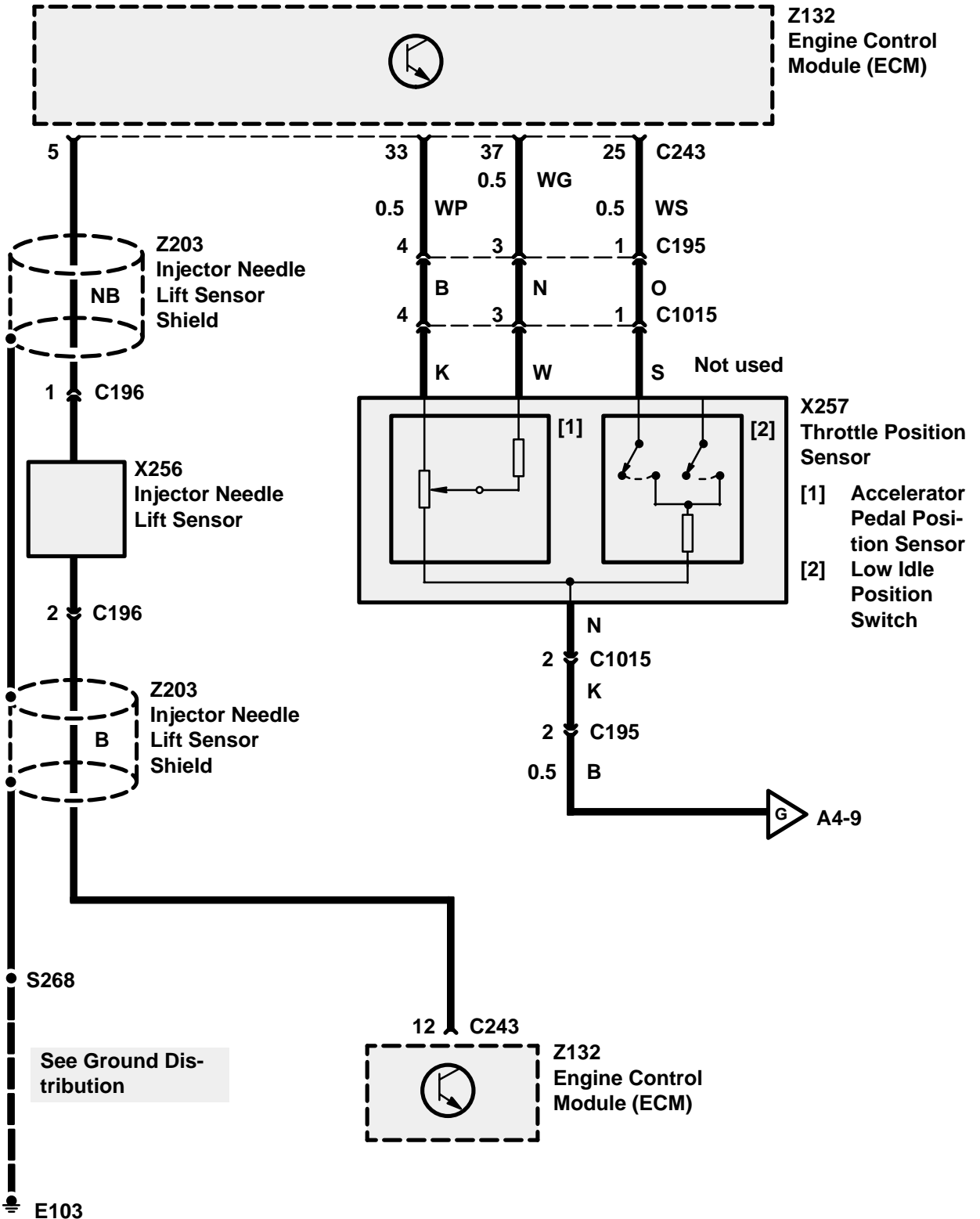
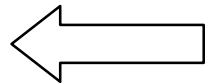

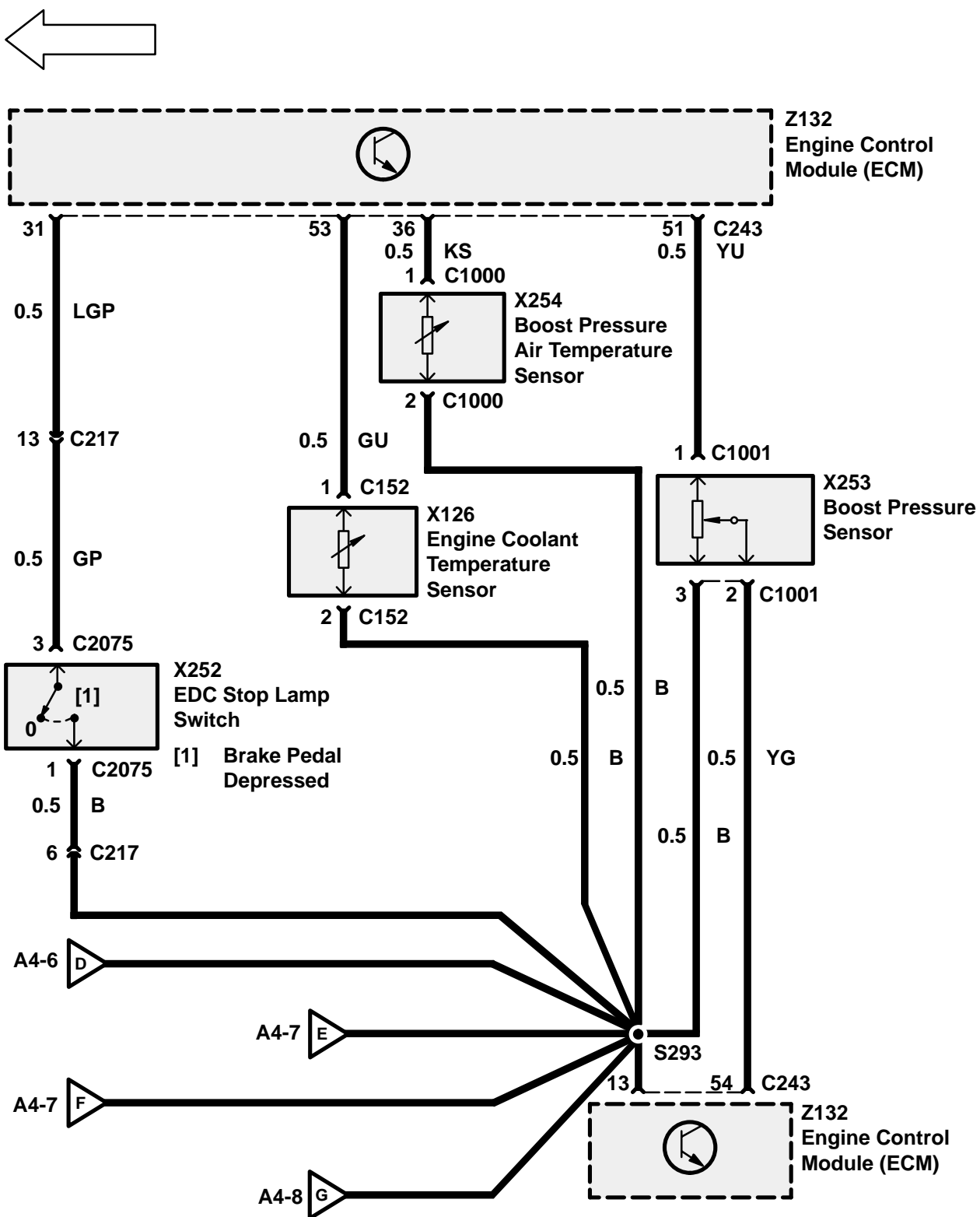



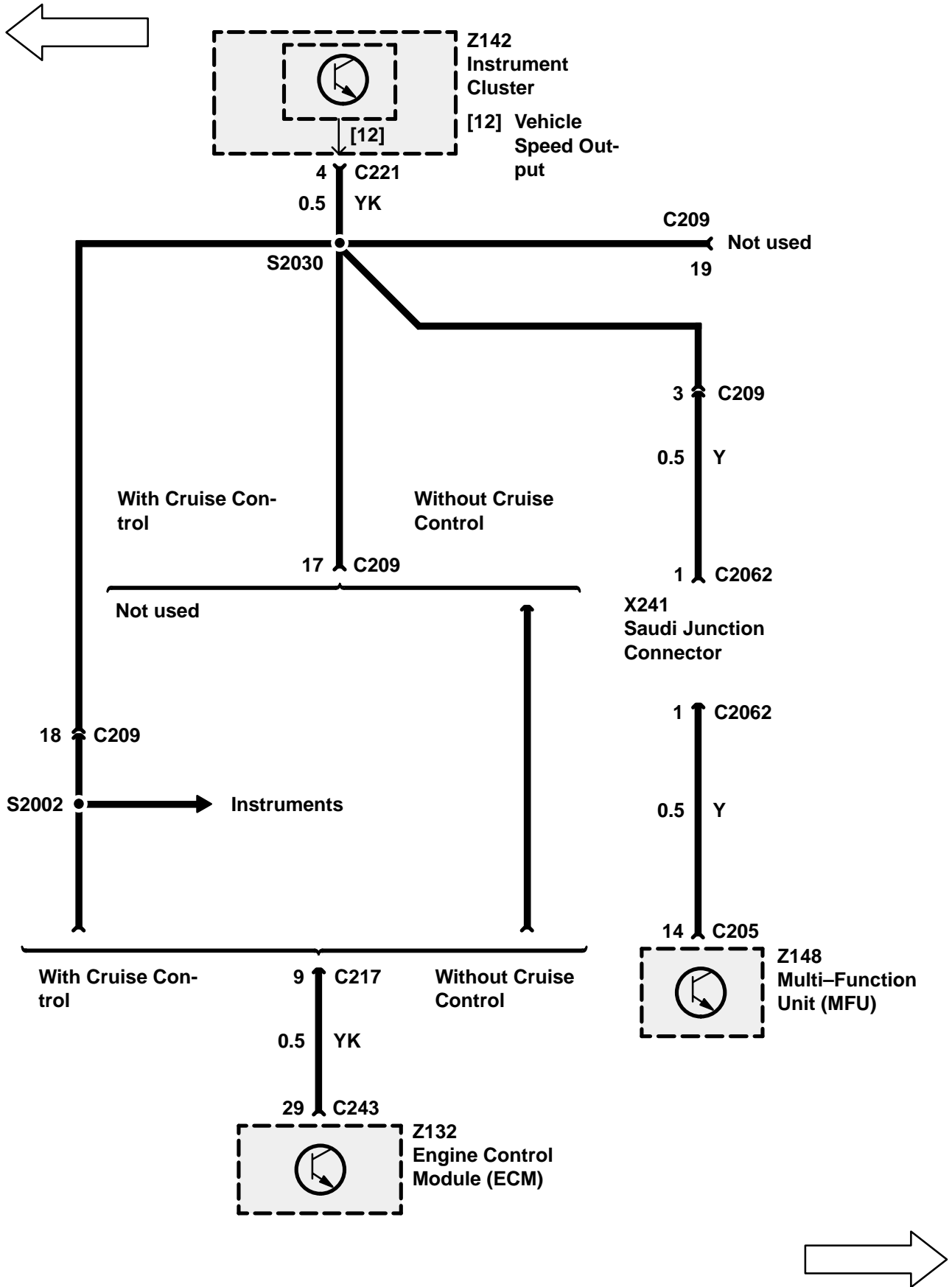

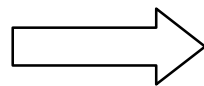
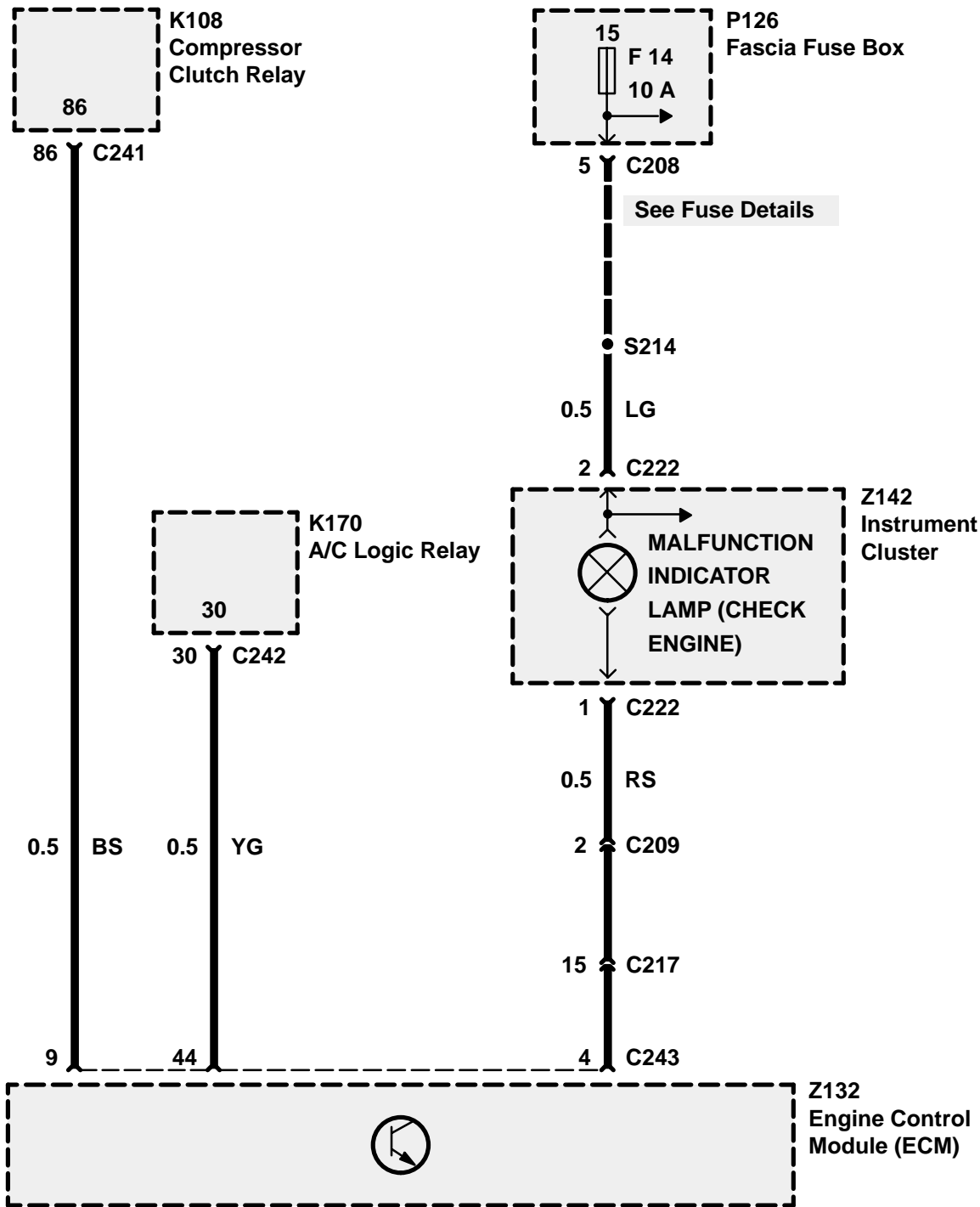
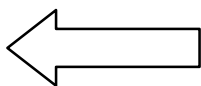

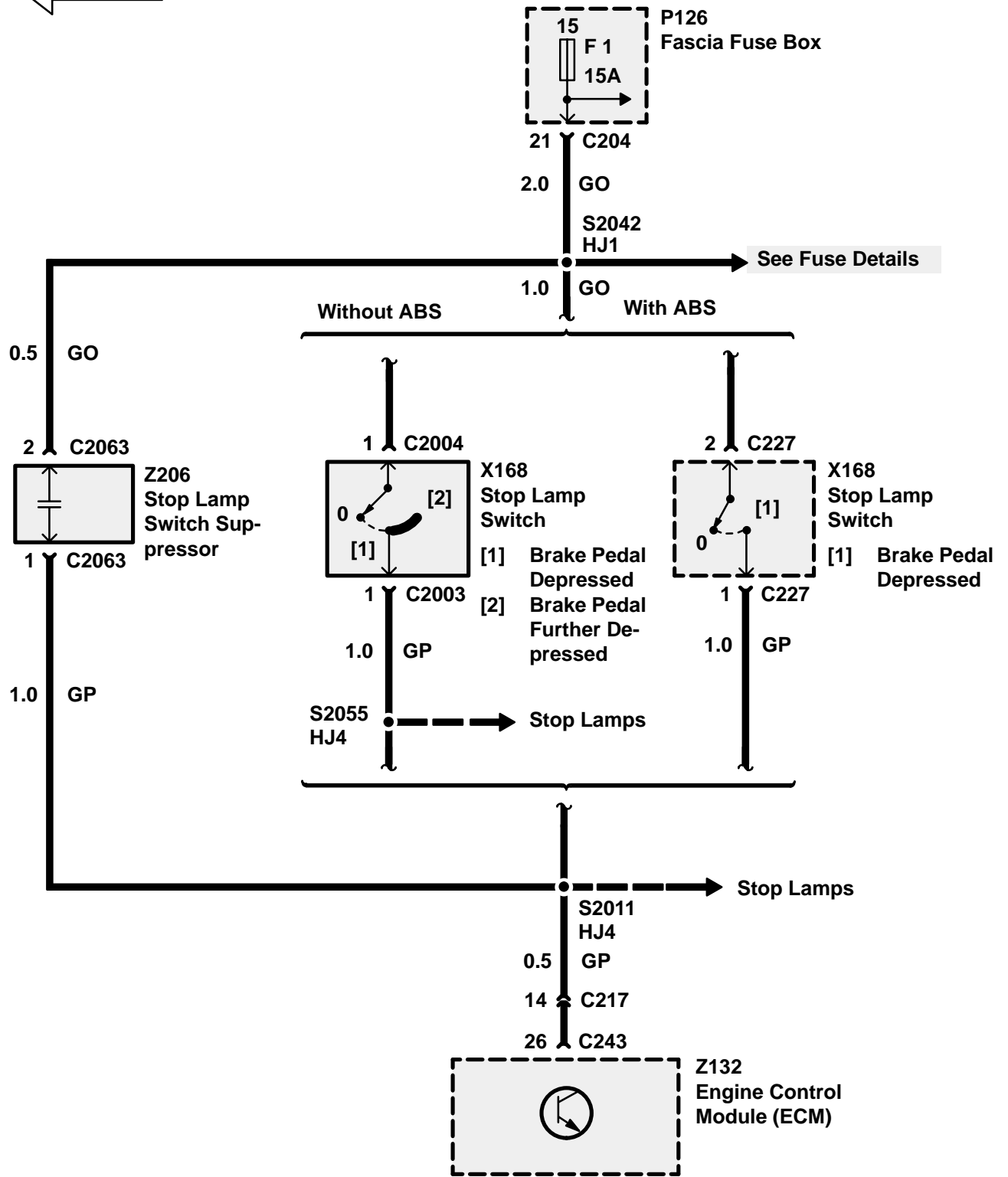
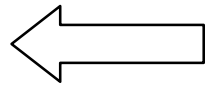

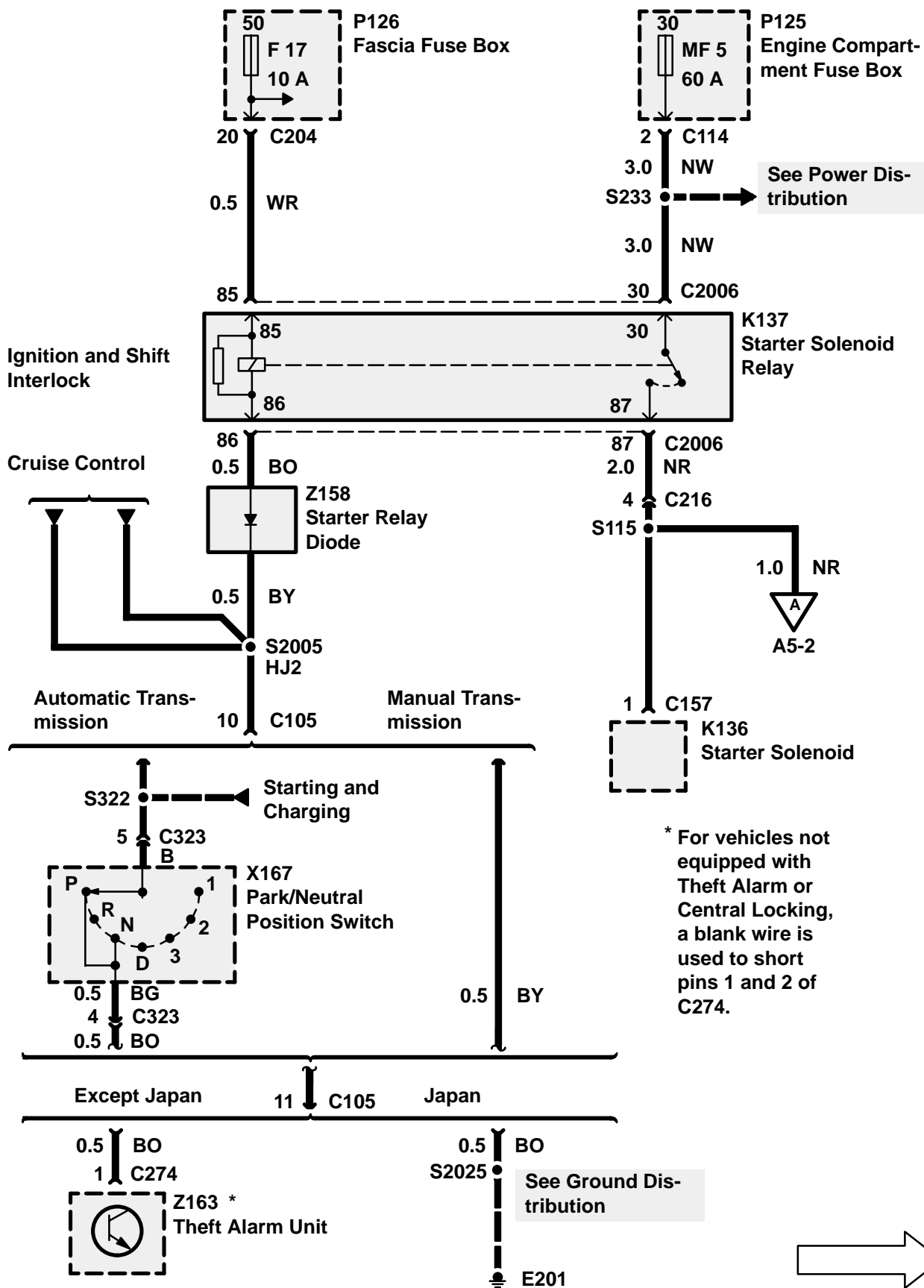

# A5 ETM

## DISCOVERY

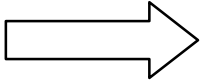
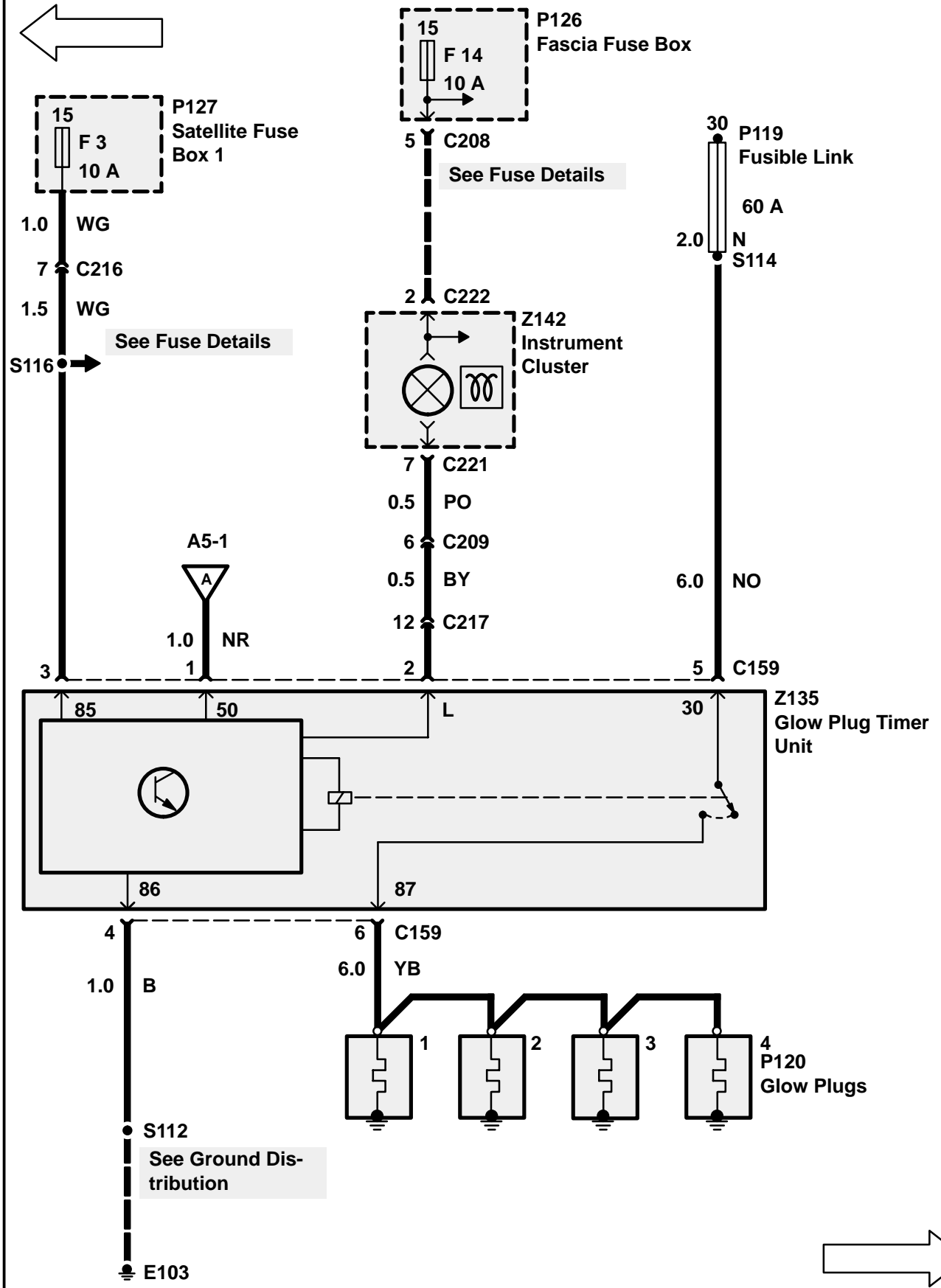

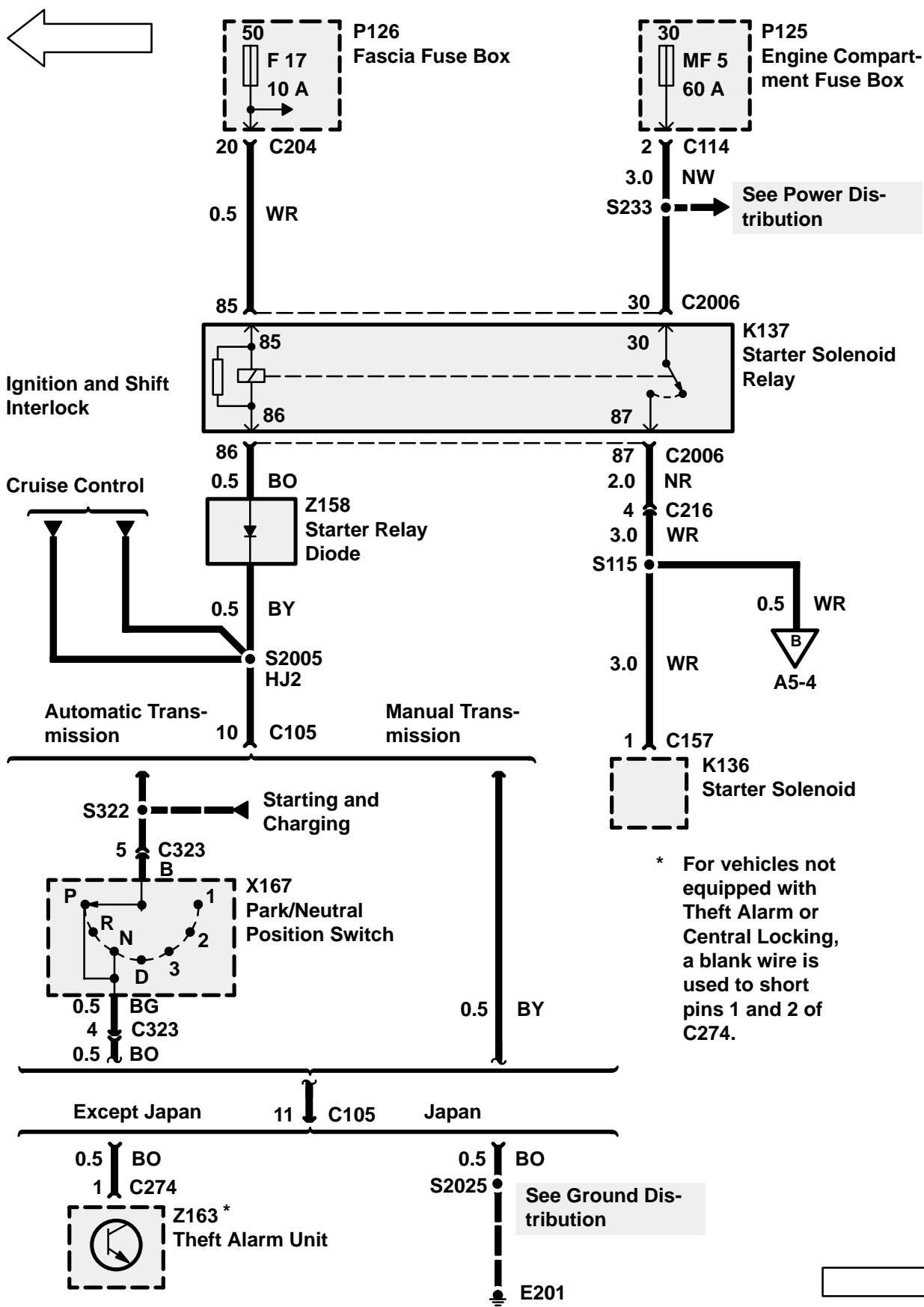

# A5 ETM

## DISCOVERY

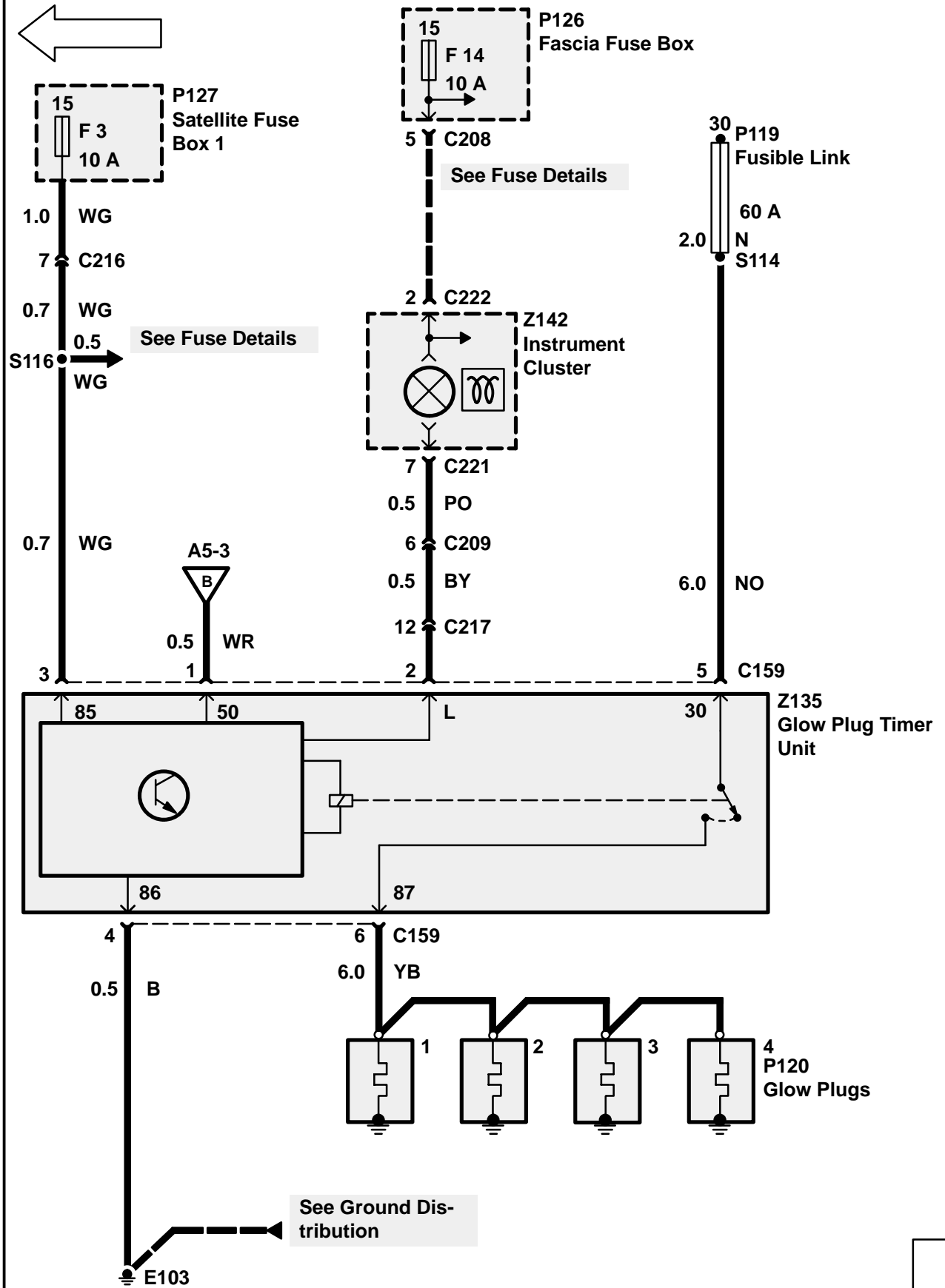

## CIRCUIT OPERATION

### Starting System

Putting the Ignition Switch (X134) in position III applies battery voltage to the Starter Solenoid Relay (K137). The Starter Solenoid Relay (K137) energizes and applies battery voltage to the Starter Solenoid (K136) and Starter (M134).

On manual transmission vehicles equipped with a theft alarm, the Theft Alarm Unit (Z163) provides a ground circuit to the Starter Solenoid Relay's (K137) 86 terminal.

On automatic transmission vehicles equipped with a theft alarm, the Theft Alarm Unit (Z163) provides a ground circuit to the Starter Solenoid Relay's (K137) 86 terminal via the Park/Neutral Position Switch (X167).

If the theft alarm is activated, the Theft Alarm Unit (Z163) will interrupt the Starter Solenoid Relay's (K137) ground path and prevent starting the engine.

For vehicles not equipped with Theft Alarm, a black wire is used to short pins 1 and 2 of C274.

### Charging System

When the Ignition Switch (X134) is in position II, battery voltage is applied to the charging system fault light. When the Generator (Z106) is being turned by the engine, its stator windings are excited by voltage applied to the Generator (Z106) via the charging system fault light. The Generator (Z106) begins to produce electricity in order to charge the vehicle Battery (P104). If the Generator (Z106) fails to produce power, the Generator (Z106) grounds the fault light control wire, causing the charging system fault light to glow.

The tachometer displays engine speed in rpm. Voltage pulses are taken from the Generator (Z106) and are generated when the engine drive belt turns the Generator pulley. The tachometer responds to the frequency of the voltage pulses, which increases proportionally to that of the engine speed.



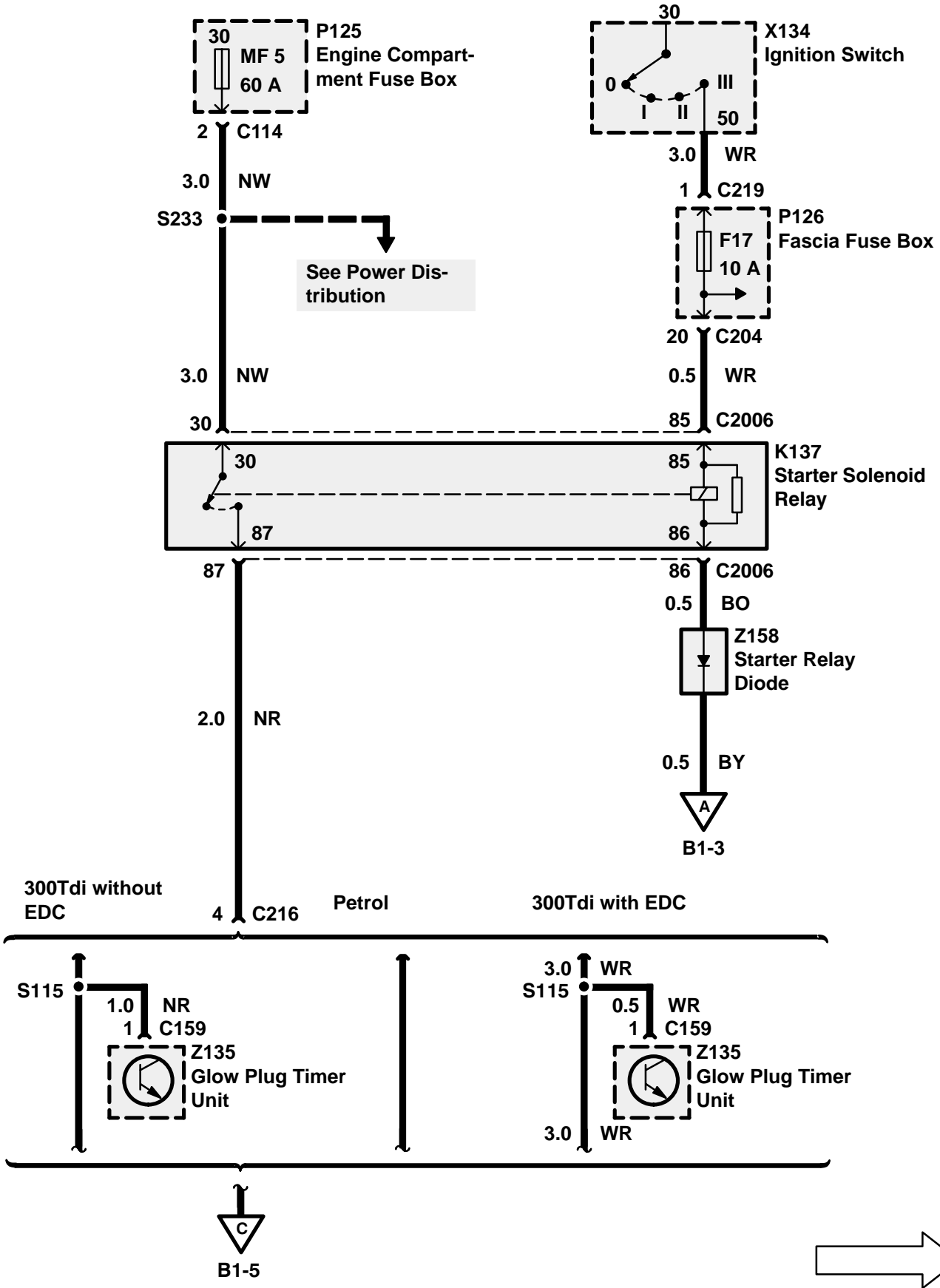

\* For vehicles not equipped with Theft Alarm or Central Locking, a blank wire is used to short pins 1 and 2 of C274.

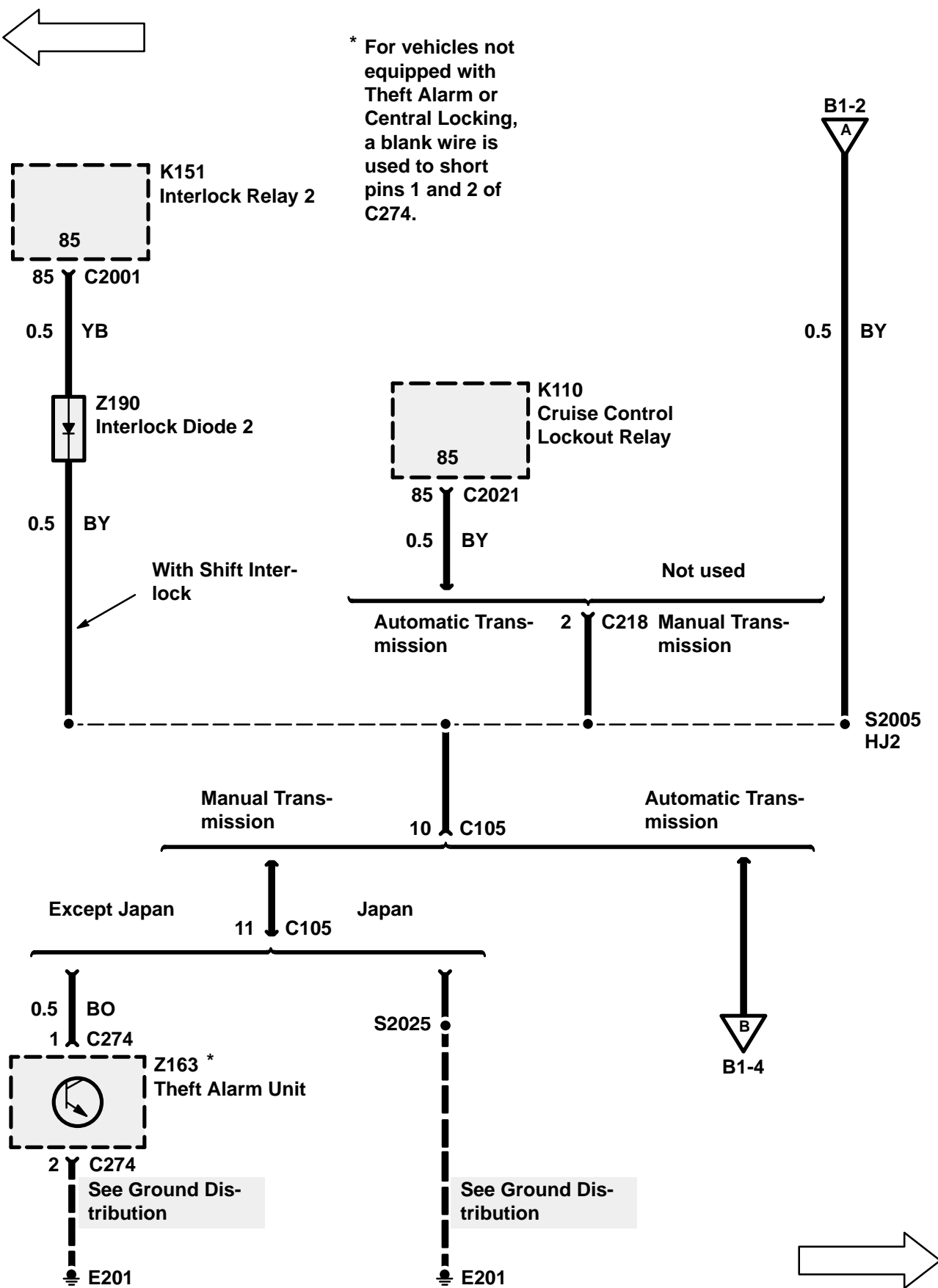

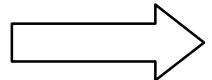
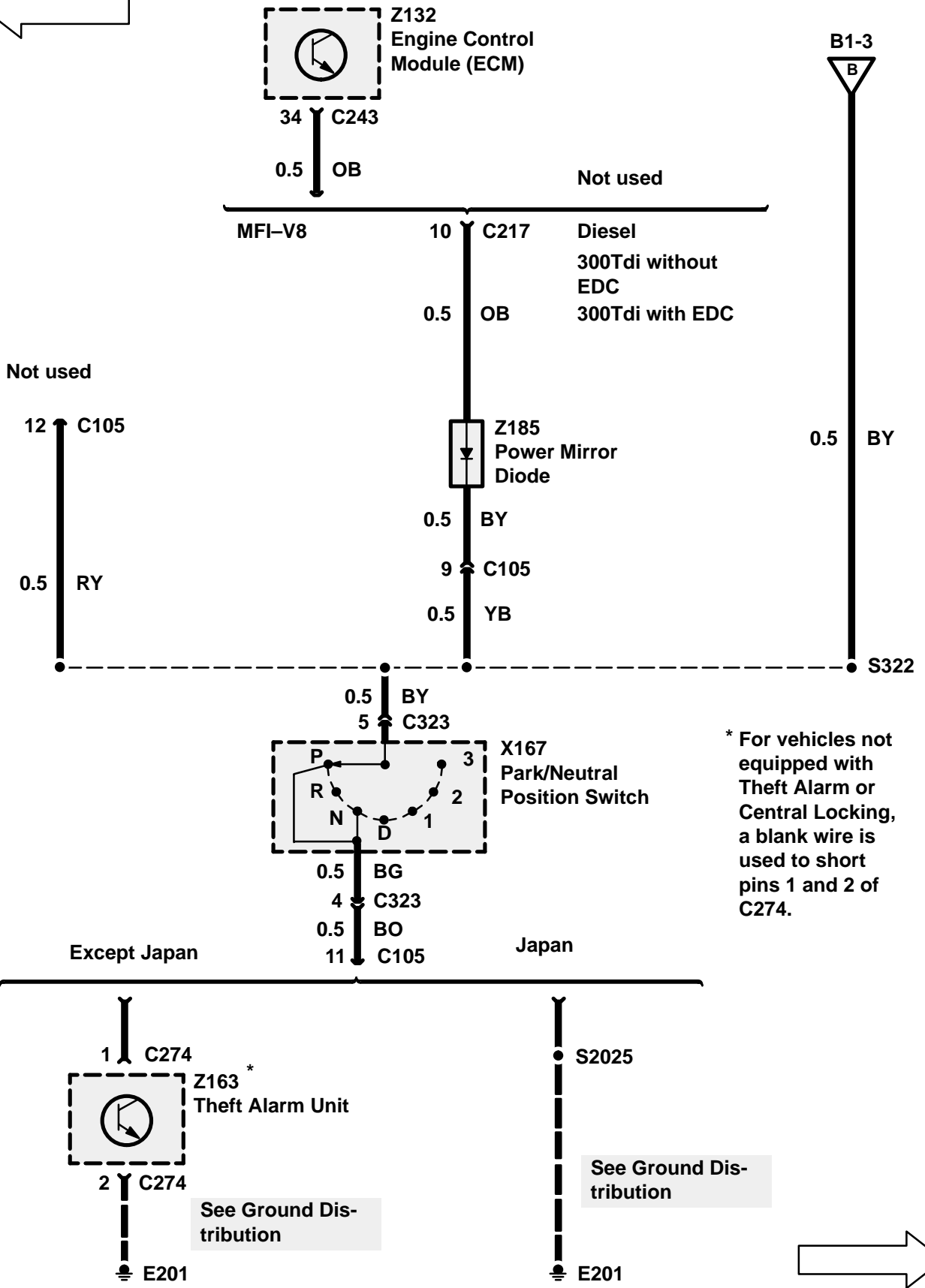
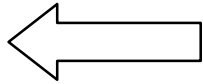

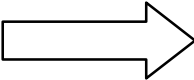
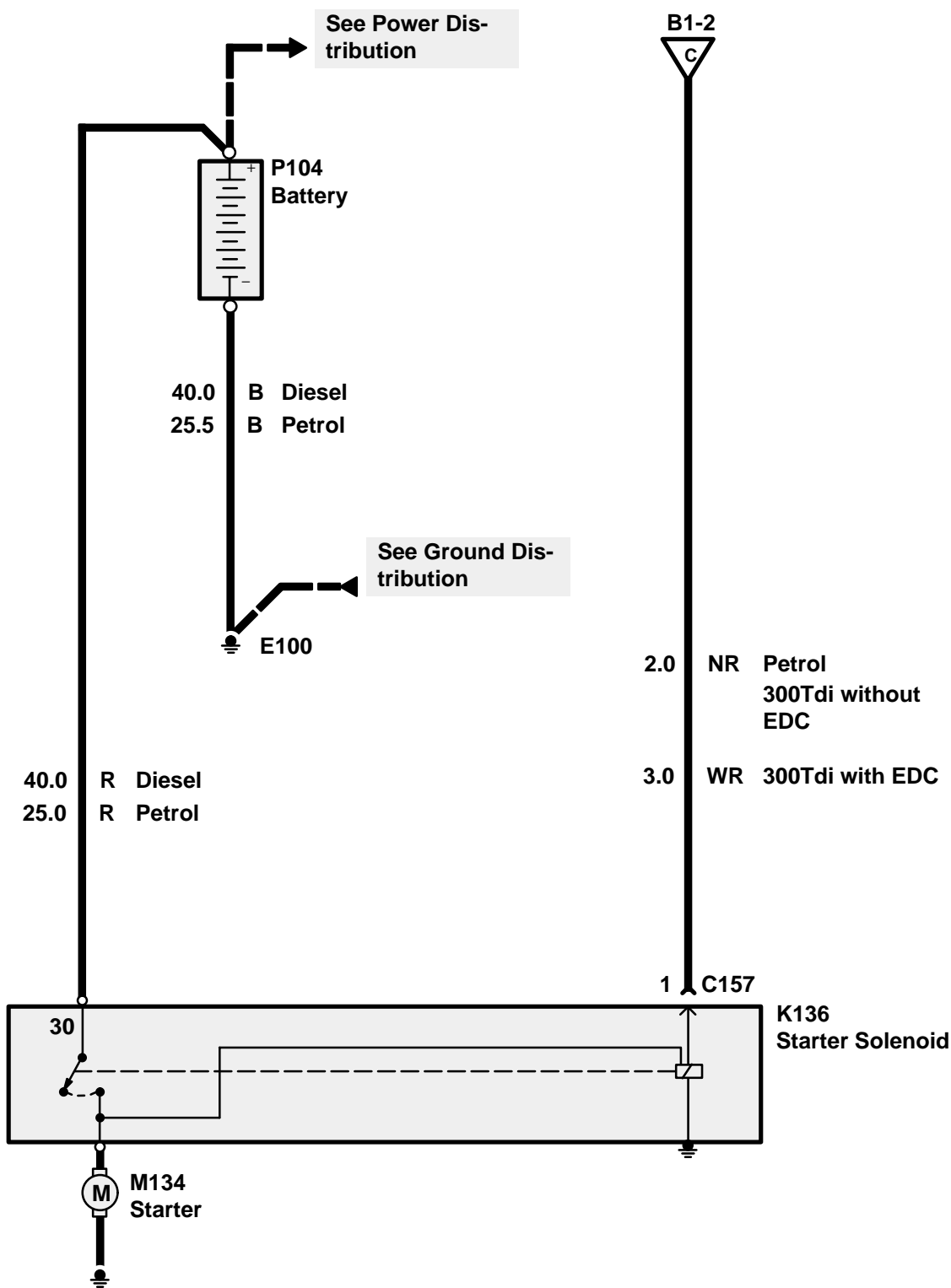
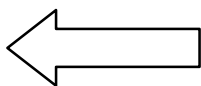

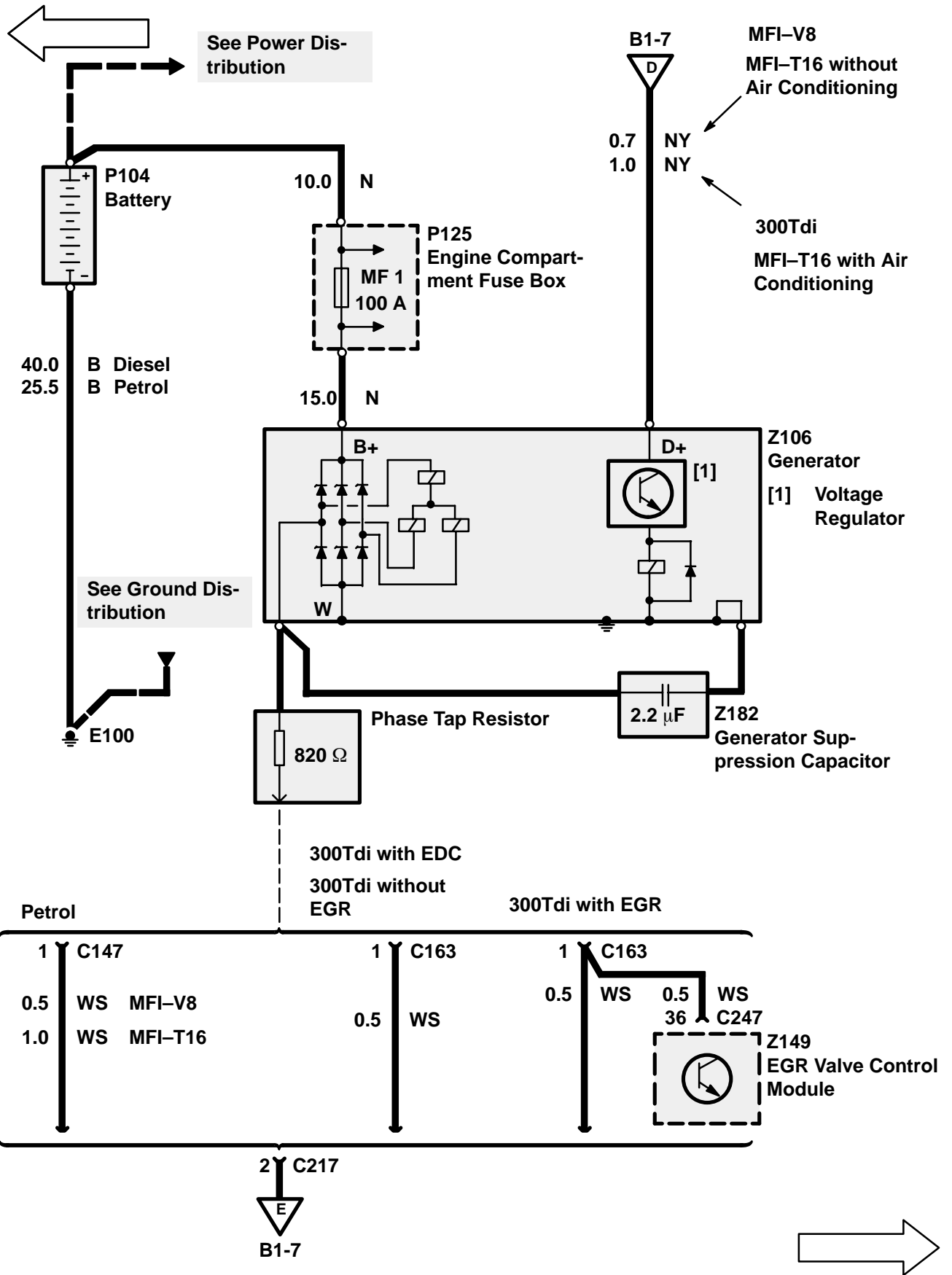

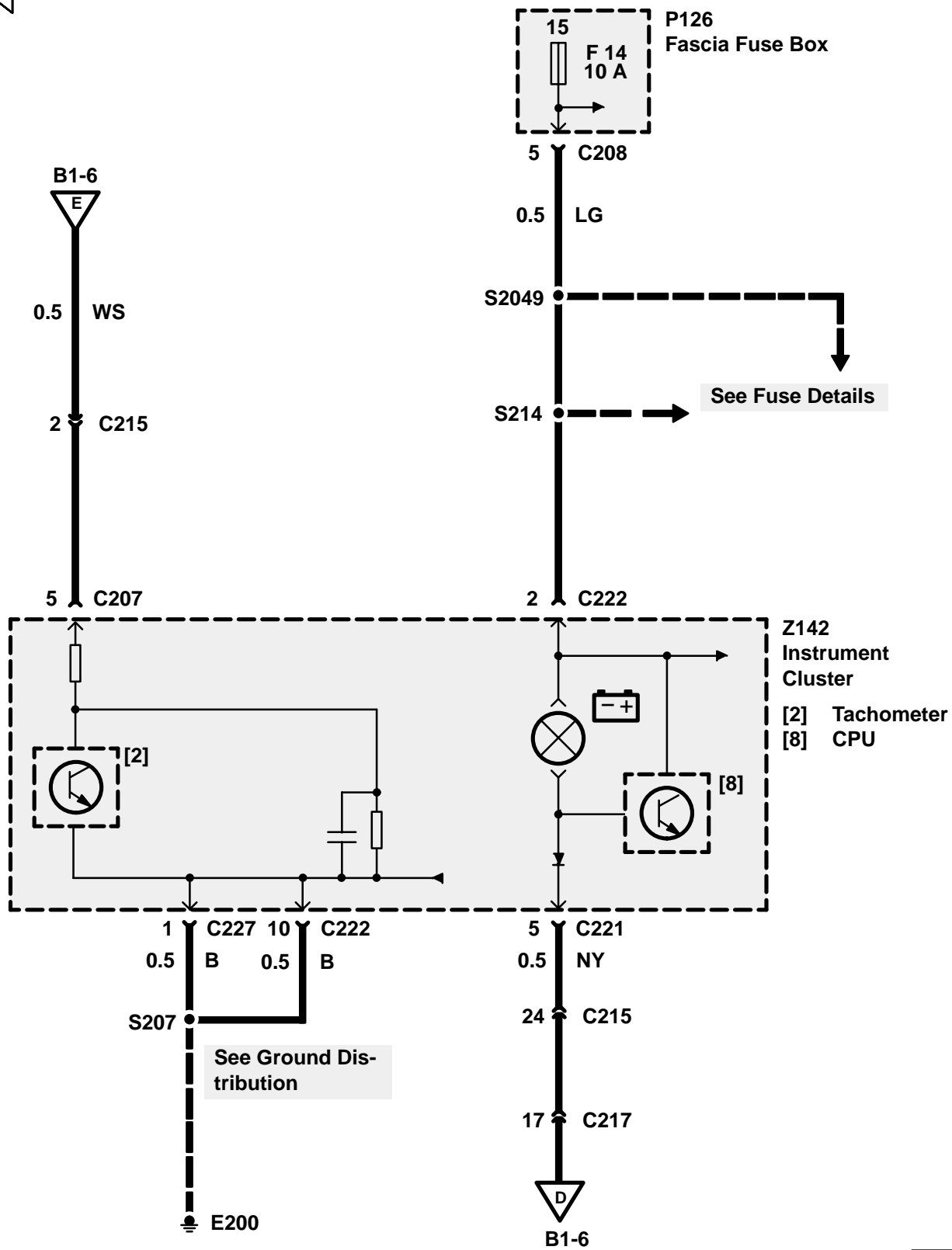
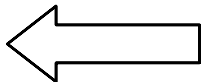

**TROUBLESHOOTING HINTS**

1. If the Starter Solenoid (K136) does not click, check the Park/Neutral Position Reverse Switch (X167) and the Theft Alarm Unit (Z163).

**SYSTEM DIAGNOSIS**

1. If the Starter Solenoid (K136) does not click and the engine does not crank, do Test A.
2. If the Starter Solenoid (K136) clicks but the engine does not crank or cranks slowly, do Test B.
3. If the charge warning light does not light with the engine off and the Ignition Switch (X134) in position II, do Test C.
4. If the charge warning light stays lit with the engine running, do Test D.

Test A

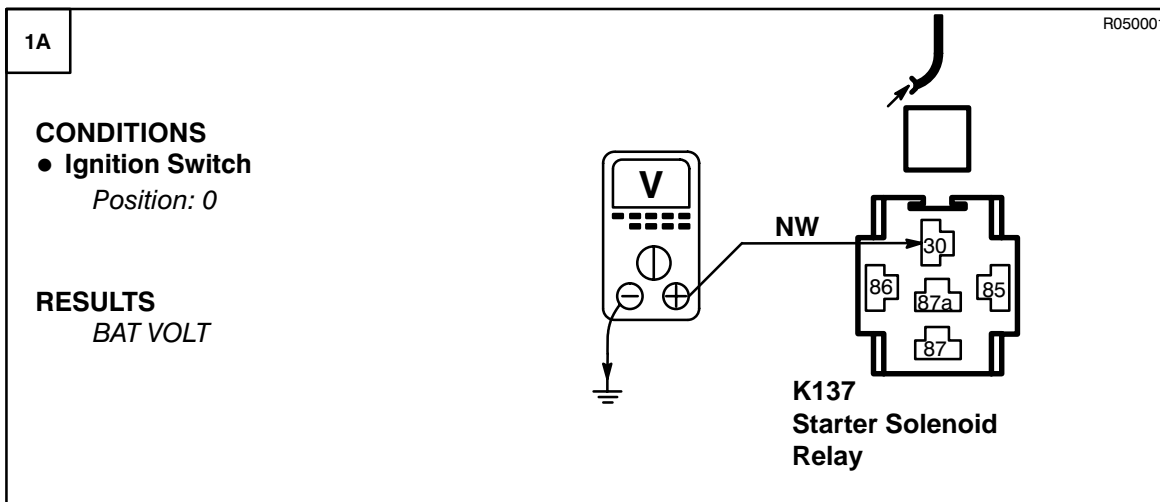

~~OK~~ PROBLEM CAUSE  
 - NW Wire

OK

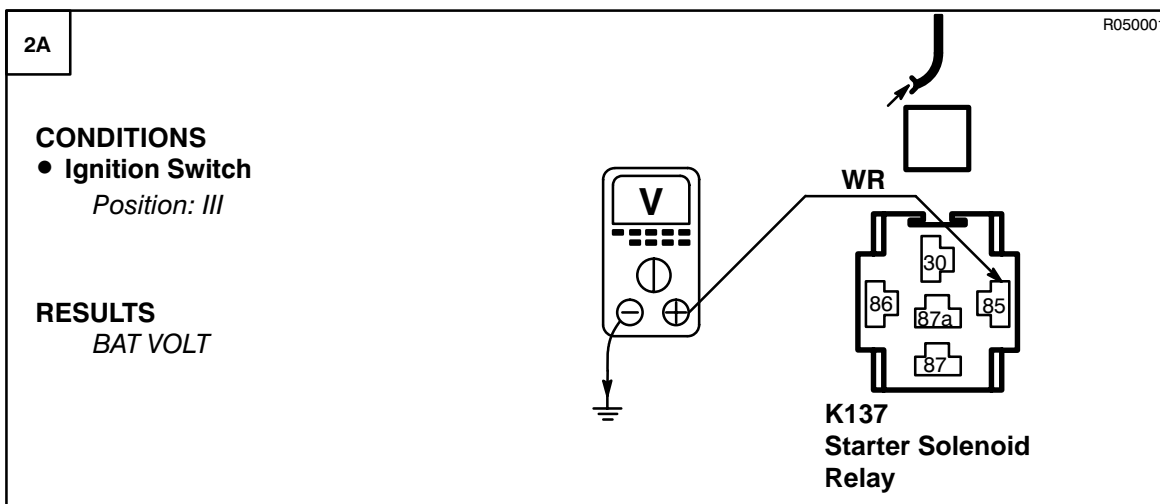
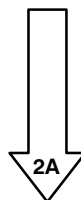

~~OK~~ PROBLEM CAUSE  
 - F17 Fuse  
 - WR Wire  
 - Ignition Switch

OK

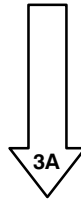



# B1 ETM

## DISCOVERY

R050001

2A

3A

**CONDITIONS**

- Ignition Switch  
*Position: 0*

**RESULTS**  
*BAT VOLT*

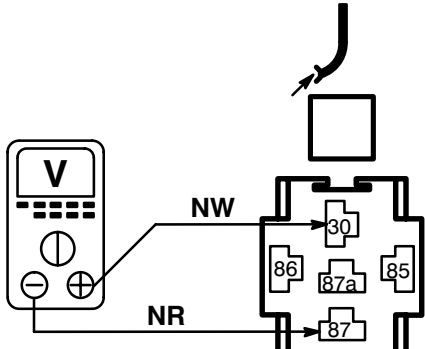

**K137  
Starter Solenoid  
Relay**



**PROBLEM CAUSE**

- B Wire
- Starter Solenoid

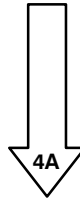

R050001

4A

**CONDITIONS**

- Ignition Switch  
*Position: 0*
- Gear Selector  
*P/N*

**RESULTS**  
*Starter (M134) cranks engine*

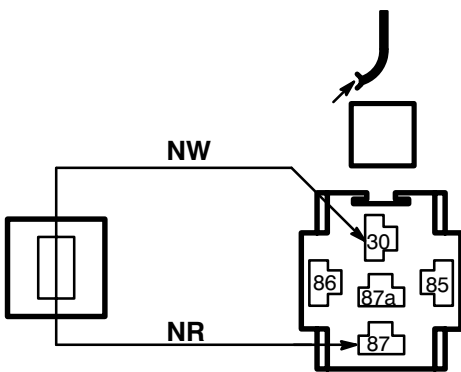

**K137  
Starter Solenoid  
Relay**



**PROBLEM CAUSE**

- NR Wire
- Starter Solenoid
- Starter

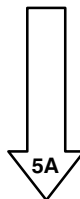

4A

5A

R050001

**CONDITIONS**

- Ignition Switch  
*Position: III*
- Gear Selector  
*P/N*

**RESULTS**  
*Starter (M134) cranks engine*

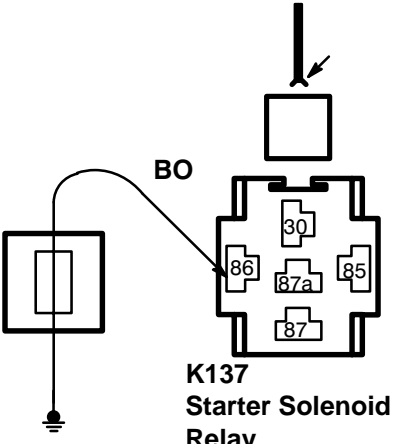

**K137  
Starter Solenoid  
Relay**



**PROBLEM CAUSE**

- BY, BO Wire
- Starter Relay Diode
- Park/Neutral Position Switch
- Theft Alarm Unit



**PROBLEM CAUSE**

- Starter Solenoid Relay

**Test B**

1B

**CONDITIONS**

- Ignition Switch  
*Position: III*

**RESULTS**  
*Less than 0.5V*

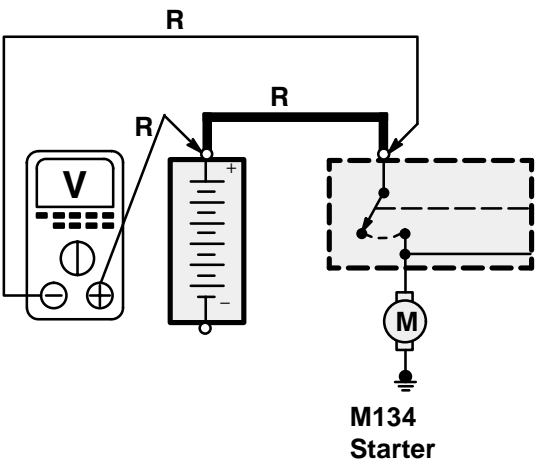

**M134  
Starter**



**PROBLEM CAUSE**

- R Wire
- Battery Terminal Connection
- Starter Solenoid
- Starter Solenoid (K136) terminal connection

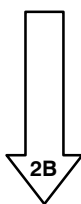

# B1 ETM

## DISCOVERY

1B

2B

**CONDITIONS**

- Ignition Switch  
*Position: III*

**RESULTS**  
*Less than 0.5V*

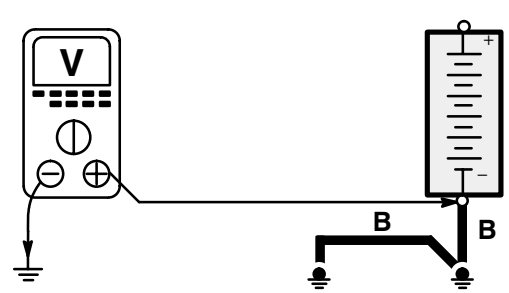



**PROBLEM CAUSE**

- B Wire
- Battery Terminal Connection
- Ground Connections



**PROBLEM CAUSE**

- Starter Solenoid
- Starter

### Test C

1C

**CONDITIONS**

- Ignition Switch  
*Position: II*

**RESULTS**  
*BAT VOLT*

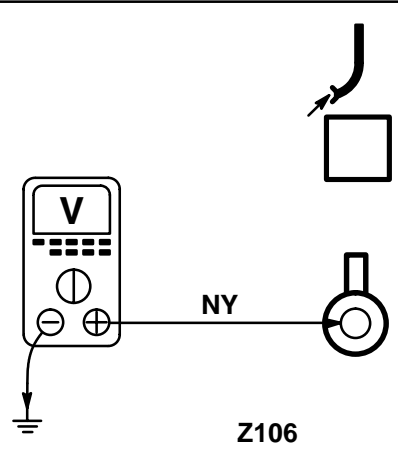

Z106  
Generator



**PROBLEM CAUSE**

- NY Wire
- Bulb
- Instrument Cluster



**PROBLEM CAUSE**

- Generator

Test D

**1D**

**CONDITIONS**  
 • Ignition Switch  
*Position: 0*

**RESULTS**  
*BAT VOLT*

Z106  
Generator

~~OK~~ PROBLEM CAUSE  
 - N Wire

OK

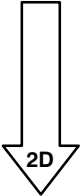

**2D**

**CONDITIONS**  
 • Ignition Switch  
*Position: 0*

**RESULTS**  
*More than 1000 ohms*

Z106  
Generator

~~OK~~ PROBLEM CAUSE  
 - NY Wire  
 - Instrument Cluster

OK PROBLEM CAUSE  
 - Generator

## CIRCUIT OPERATION

With the Cruise Control Switch (X115) on, voltage from Fuse F18 is applied to the Cruise Control ECU (Z121), Cruise Control Vacuum Pump (M103), Steering Wheel Cruise Switches (X266) through the WY wire, Rotary Coupler (Z104) and PB wire. The Cruise Control ECU (Z121) is grounded at terminal 8 through the B wire to E201.

### Cruise Control Vacuum Pump (M103)

With the Cruise Control Switch (X115) on, voltage is applied to the Cruise Control Vacuum Pump (M103) through the WU wire. When a cruise speed is set, the Cruise Control ECU (Z121) applies ground through the BR wire to operate the pump motor and applies ground through the BY wire to close the normally open solenoid valve in the pump. The pump applies vacuum to the actuator.

### SET/ACCEL

To set a cruise speed, the Cruise Control Switch (X115) must be on and vehicle speed must exceed 28 mph (45 km/h). When the SET/ACCEL Switch is depressed under these conditions, voltage from Fuse F18 is applied to terminal 3 of the Cruise Control ECU (Z121) through the closed Cruise Control Switch (X115) and Steering Wheel Cruise Switches (X266), causing the vacuum pump to operate. When the SET/ACCEL Switch is released, voltage is removed from terminal 3, signalling the ECU to set the speed.

### RES/DECEL

When the RES/DECEL Switch is depressed, voltage is applied to terminal 4 of the Cruise Control ECU (Z121). This voltage signals the ECU to disengage the system and the vehicle slows down. When the switch is depressed a second time, voltage is again applied to the ECU and the vehicle returns to the previously set speed.

### Speed Input

Terminal 11 of the Cruise Control ECU (Z121) monitors the Vehicle Speed output signal from the Instrument Cluster (Z142) through the YK wire. This signal is a pulsing voltage and its frequency changes with vehicle speed.

### System Disable

The Cruise Control System can be disabled in one of four ways:

1. The Cruise Control Switch (X115) is put in the 0 position, removing power from the Cruise Control ECU (Z121) and vacuum pump, and erasing the set speed memory.
2. The RES/DECEL Switch is depressed, signalling the Cruise Control ECU (Z121) to disengage the system.
3. The brake pedal is depressed and a vacuum valve in the Brake Switch Vent Valve opens (X112). This vents vacuum to the actuator valve and releases the throttle.

4. The Voltage applied to Cruise Control ECU (Z121) terminal 9 is interrupted, causing the Cruise Control ECU (Z121) to turn off the vacuum pump and de-energize the vacuum solenoid valve. This voltage path is interrupted when the brake pedal is depressed, the Clutch Pedal is depressed, or the vehicle is in Park or Neutral. With the brake pedal depressed, the Brake Switch Vent Valve (X112) moves to 1 and the circuit is interrupted. With the vehicle in Park or Neutral the Park/Neutral Position Switch (X167) energizes the Cruise Control Lockout Relay (K110) by grounding the relay's coil. The relay then opens its contacts, interrupting the circuit. With the clutch pedal depressed, the Clutch Switch (X200) moves to 1 and the circuit is interrupted.

#### Road Test

**CAUTION: DO NOT ENGAGE CRUISE CONTROL WHEN VEHICLE IS BEING USED IN LOW TRANSFER GEARS**

**WARNING:** The use of cruise control is not recommended on winding, snow covered or slippery roads, or in heavy traffic conditions where a constant speed cannot be maintained.

1. Start the engine and depress the Cruise Control Switch (X115) to activate the Cruise Control System. Accelerate to approximately 30 mph (50 km/h) and press the SET/ACCEL Switch. Immediately release the switch and remove foot from the accelerator pedal. The vehicle should maintain the speed at which the SET/ACCEL Switch was pressed.
2. Press the SET/ACCEL Switch and hold at that position. The vehicle should accelerate smoothly until the switch is released. The vehicle should now maintain the new speed at which the SET/ACCEL Switch was released.
3. Press the RES/DECEL Switch while the vehicle is in the cruise control mode. The cruise control should disengage. Slow to approximately 35 mph (55 km/h) and press the RES/DECEL Switch. Immediately release the switch and remove foot from the accelerator. The vehicle should smoothly accelerate to the previously set speed. Increase speed using the accelerator pedal. Releasing the pedal should return the vehicle to the previously set speed.
4. Depressing the brake pedal should immediately disengage the Cruise Control System and return the vehicle to driver's control at accelerator pedal. Press the RES/DECEL Switch and the vehicle should accelerate to the previously set speed without operation of the accelerator pedal.
5. Press the RES/DECEL Switch and allow the vehicle to decelerate to below 26 mph (42 km/h). Press the RES/DECEL Switch and the Cruise Control System should remain disengaged.
6. Press the SET/ACCEL Switch below 28 mph (45 km/h) and the Cruise Control System should remain disengaged. Accelerate the vehicle above 28 mph (45 km/h), press the RES/DECEL Switch and remove foot from the accelerator pedal. The vehicle should smoothly adjust to the previously memorized speed.
7. Pressing the Cruise Control Switch (X115) should immediately disengage the Cruise Control System and erase the previously set speed from ECU memory.

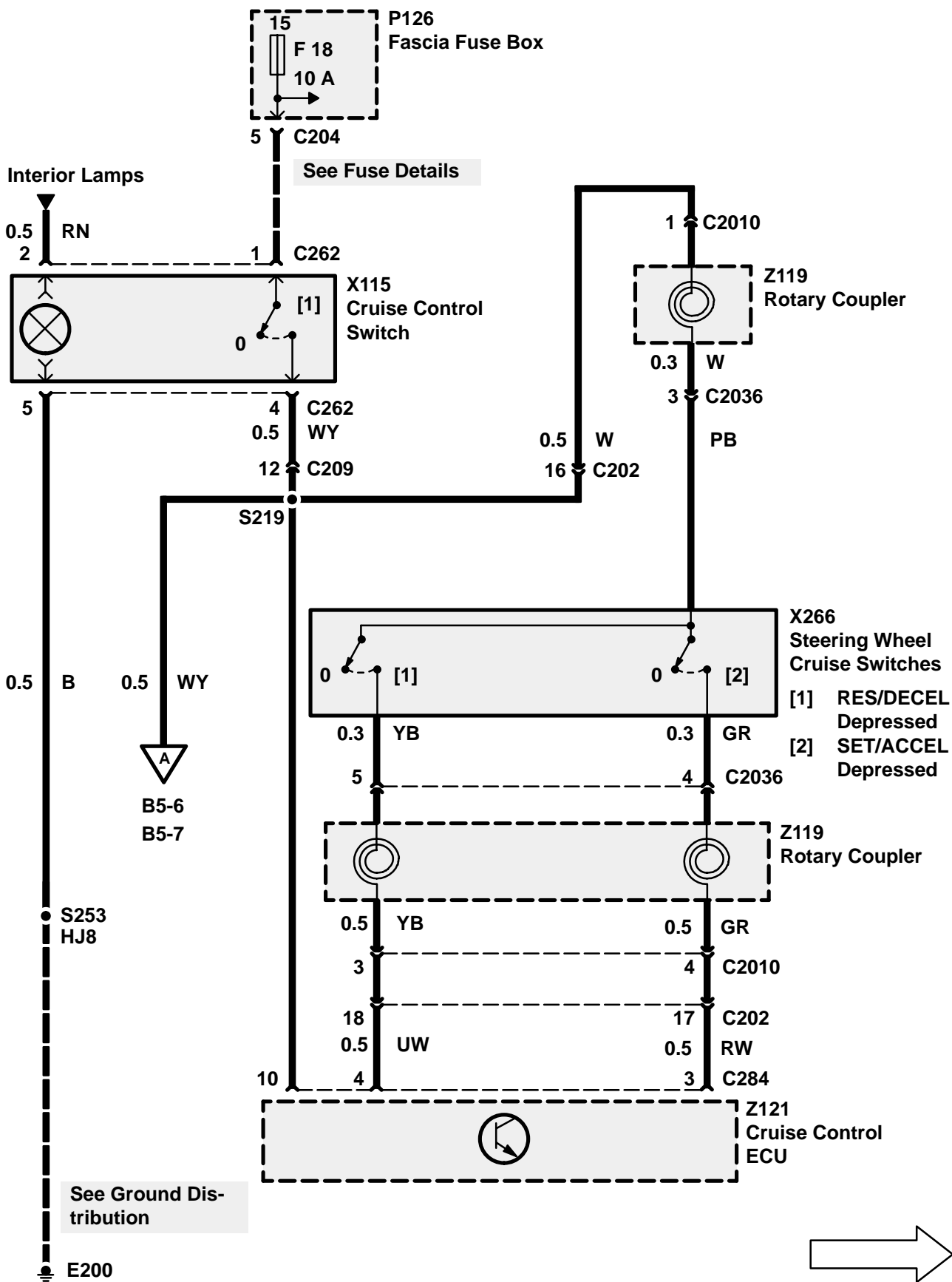

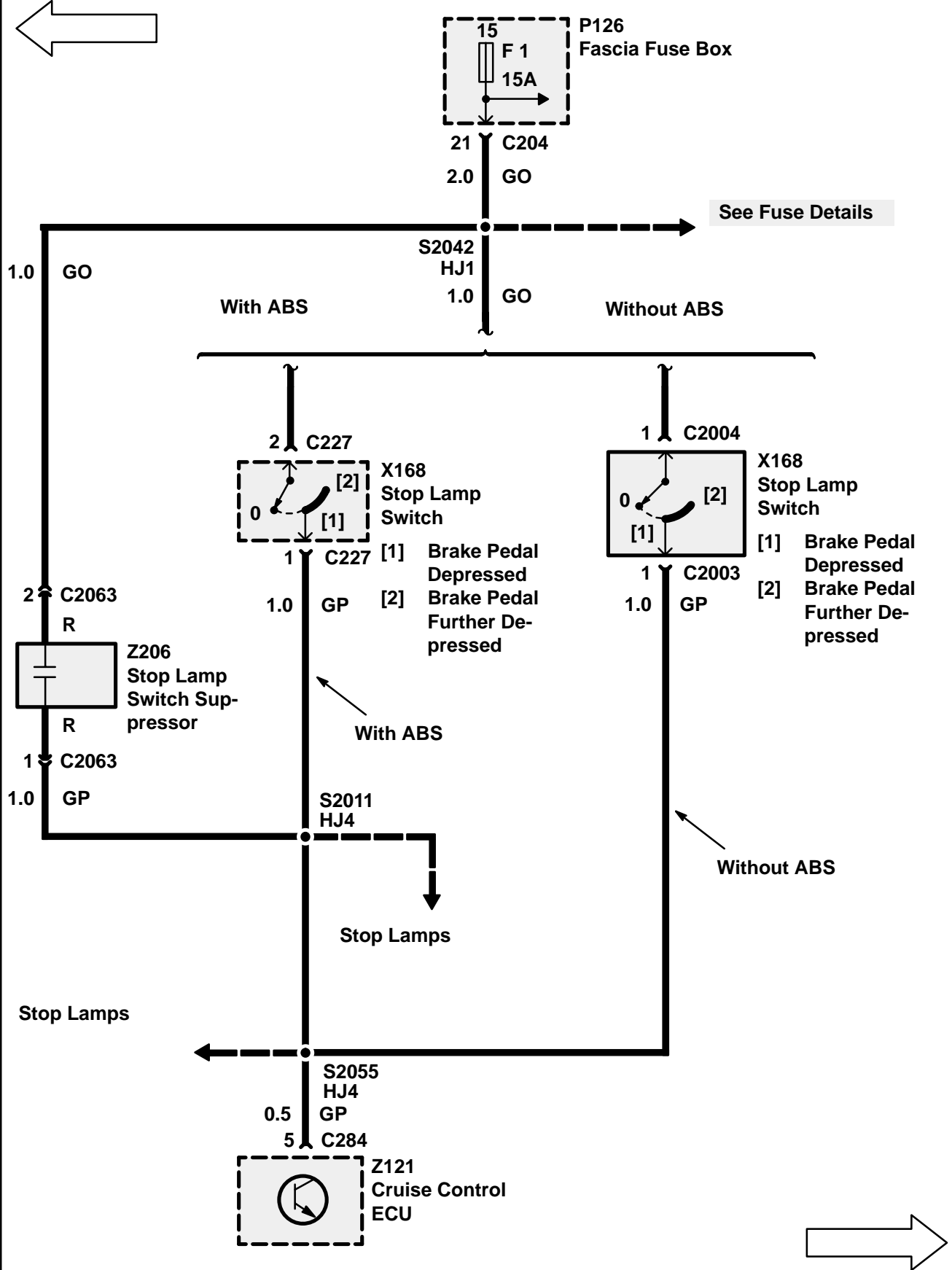





# B5 ETM

## DISCOVERY

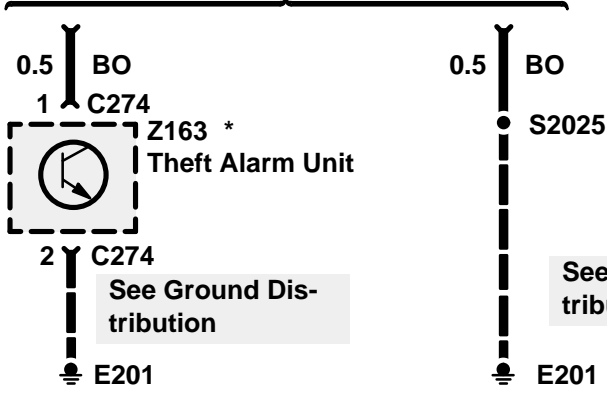
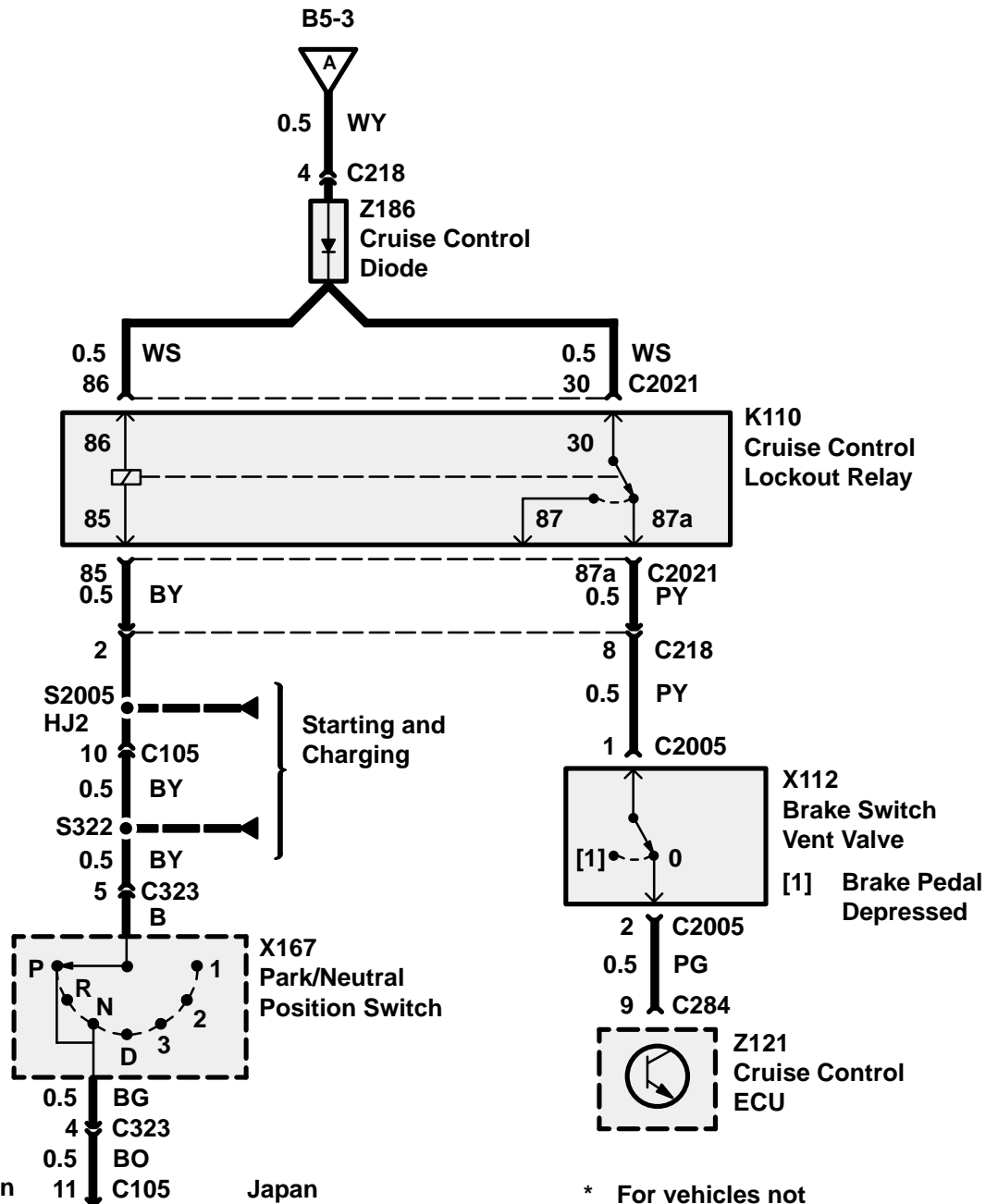
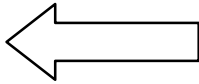

\* For vehicles not equipped with Theft Alarm or Central Locking, a blank wire is used to short pins 1 and 2 of C274.

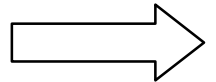

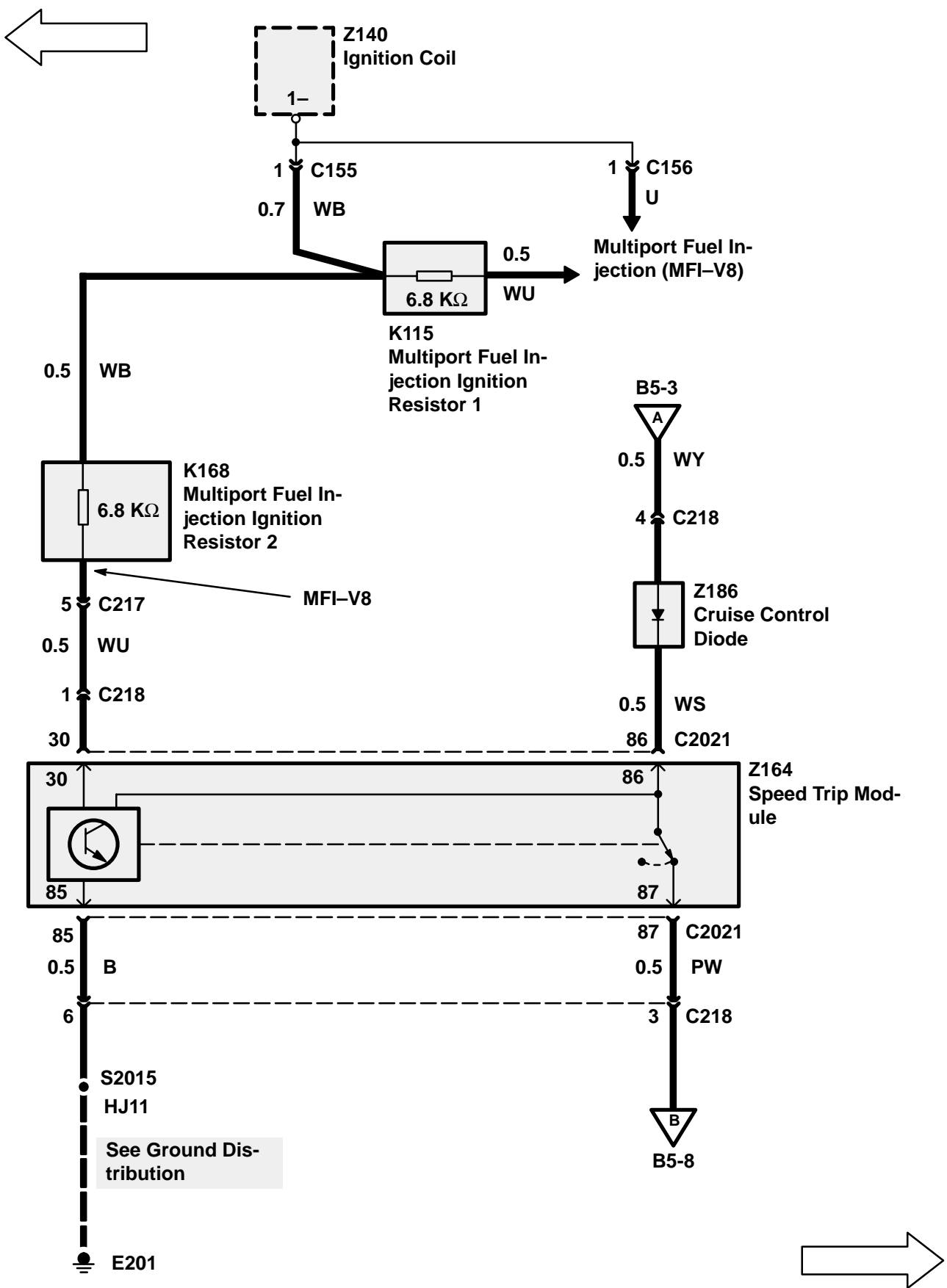

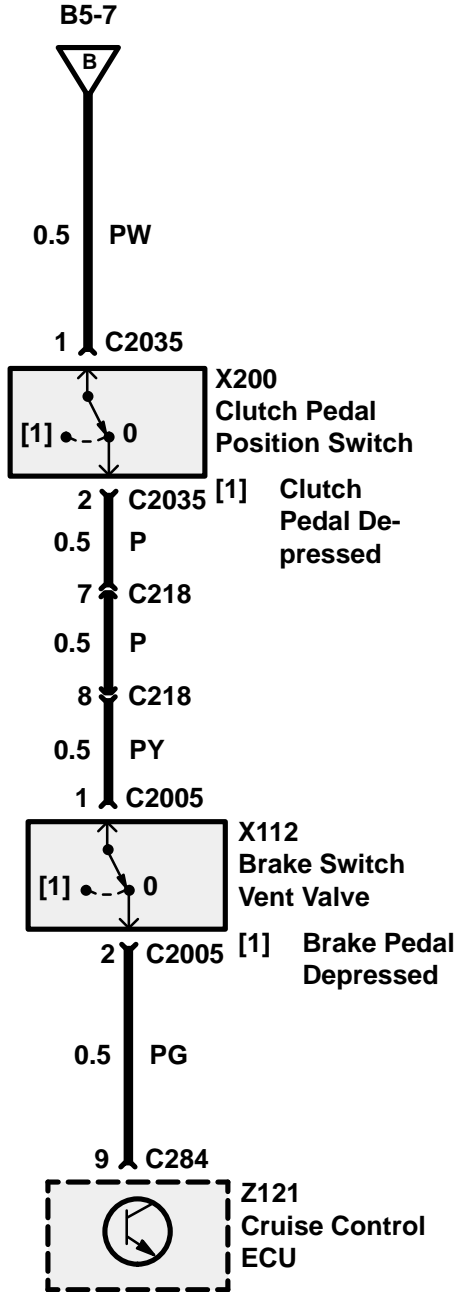
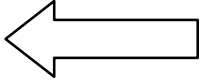

**TROUBLESHOOTING HINTS**

5. If the cruise control system operates but the cruise control switch light does not illuminate, check the bulb, B wire and RN wire.
6. Inspect vacuum hoses for kinks and restrictions.
7. Inspect actuator linkage for restrictions and adjustment.

**SYSTEM DIAGNOSIS**

1. If the cruise control system does not operate correctly and the vehicle is equipped with a manual transmission, do Test A.
2. If the cruise control system does not operate correctly and the vehicle is equipped with an automatic transmission, do Test B.

Test A

R150001

1A

**CONDITIONS**

- Ignition Switch  
*Position: II*

**RESULTS**

- Cruise Control Switch  
*On = BAT VOLT*  
*Off = 0V*

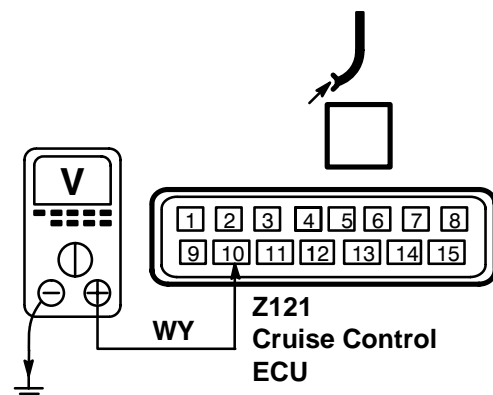

Z121  
Cruise Control  
ECU



**PROBLEM CAUSE**

- F18 Fuse
- WY Wire
- GLG Wire
- Cruise Control Switch

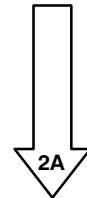

R150001

2A

**CONDITIONS**

- Ignition Switch  
*Position: II*
- Cruise Control Switch  
*On*
- Engine running

**RESULTS**

- Brake Switch Vent Valve
- Clutch Pedal Position Switch  
*BAT VOLT = Released*  
*0V = Depressed*

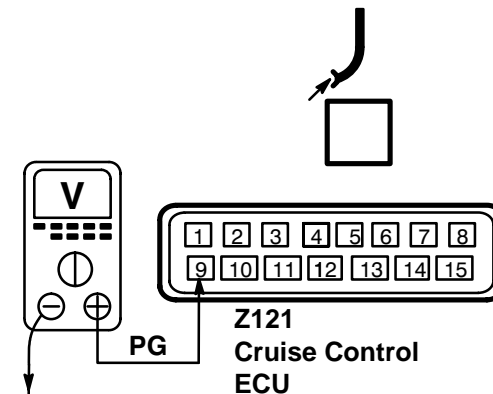

Z121  
Cruise Control  
ECU

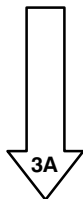

**GO TO TEST C**

2A

3A

R020032

**CONDITIONS**

- Ignition Switch  
*Position: II*
- Cruise Control Switch  
*On*
- Engine running

**RESULTS**

- Clutch Pedal Position Switch  
*BAT VOLT = Released*  
*0V = Depressed*

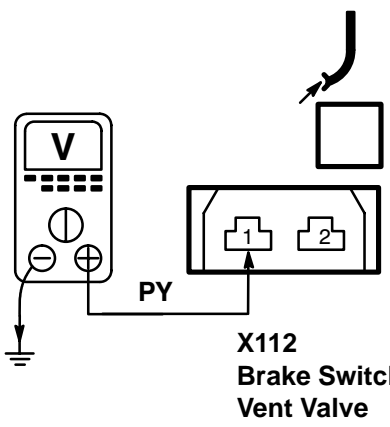

X112  
Brake Switch  
Vent Valve

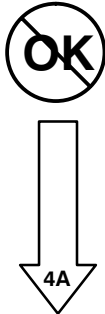

**OK** **PROBLEM CAUSE**

- PG Wire
- Brake Switch Vent Valve

4A

R020032

**CONDITIONS**

- Ignition Switch  
*Position: II*
- Cruise Control Switch  
*On*
- Engine running

**RESULTS**

*BAT VOLT*

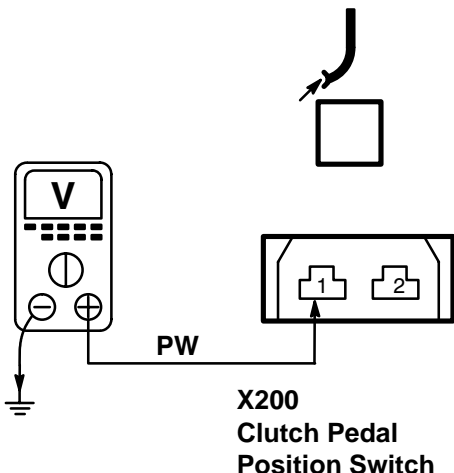

X200  
Clutch Pedal  
Position Switch

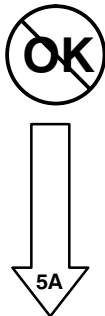

**OK** **PROBLEM CAUSE**

- P Wire
- PY Wire
- Clutch Pedal Position Switch

R050001

4A

5A

**CONDITIONS**

- Ignition Switch  
*Position: II*
- Cruise Control Switch  
*On*
- Engine running

**RESULTS**  
*BAT VOLT*

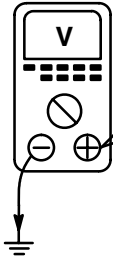

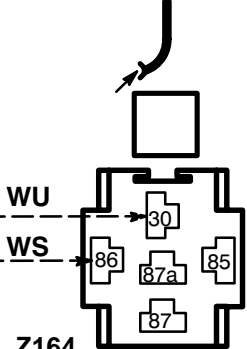

Z164  
Speed Trip Module



**PROBLEM CAUSE**

- WU, WB Wire
- WS, WY Wire
- Multipoint Fuel Injection Ignition Resistor 2
- Cruise Control Diode

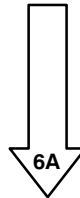

R050001

6A

**CONDITIONS**

- Ignition Switch  
*Position: 0*

**RESULTS**  
*Less than 1 ohm*

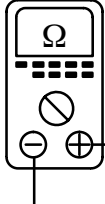

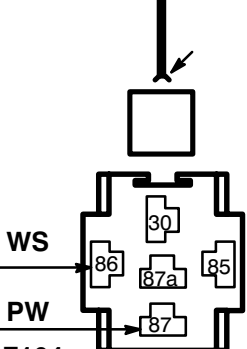

Z164  
Speed Trip Module



**PROBLEM CAUSE**

- Speed Trip Module



**PROBLEM CAUSE**

- PW Wire
- B Wire



**Test B**

R150001

1B

**CONDITIONS**

- Ignition Switch  
*Position: II*

**RESULTS**

- Cruise Control Switch  
*On = BAT VOLT*  
*Off = 0V*

Z121  
Cruise Control  
ECU



**PROBLEM CAUSE**

- F18 Fuse
- WY Wire
- GLG Wire
- Cruise Control Switch

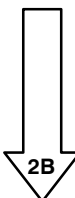

R150001

2B

**CONDITIONS**

- Ignition Switch  
*Position: II*
- Cruise Control Switch  
*On*
- Gear Selector  
*D*

**RESULTS**

- Brake Switch Vent Valve  
*BAT VOLT = Released*  
*0V = Depressed*

Z121  
Cruise Control  
ECU

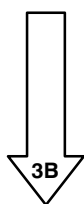

**GO TO TEST C**

2B

3B

R020032

**CONDITIONS**

- Ignition Switch  
*Position: II*
- Gear Selector  
*D*

**RESULTS**

- Cruise Control Switch  
*On = BAT VOLT*  
*Off = 0V*

Diagram description: A voltmeter is connected to terminal PY of the X112 Brake Switch Vent Valve. A curved arrow points to a square symbol above the valve.

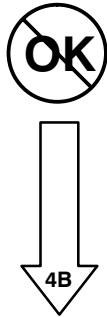

**OK** PROBLEM CAUSE

- PG Wire
- Brake Switch Vent Valve

4B

R050001

**CONDITIONS**

- Ignition Switch  
*Position: II*

**RESULTS**

- Cruise Control Switch  
*On = BAT VOLT*  
*Off = 0V*

Diagram description: A voltmeter is connected to terminals 86 and 87 of the K110 Cruise Control Lockout Relay. A curved arrow points to a square symbol above the relay.

**OK** PROBLEM CAUSE

- WS Wire
- WY Wire
- Cruise Control Diode

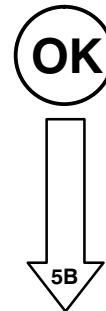

R050001

4B

5B

**K110**  
Cruise Control  
Lockout Relay

**CONDITIONS**

- Ignition Switch  
*Position: 0*

**RESULTS**

- Gear Selector
 

<i>P = 0-1 Ω</i>	<i>3 = &gt;100 Ω</i>
<i>R = &gt;100 Ω</i>	<i>2 = &gt;100 Ω</i>
<i>N = 0-1 Ω</i>	<i>1 = &gt;100 Ω</i>
<i>D = &gt;100 Ω</i>	

- OK**
- PROBLEM CAUSE**
- BY Wire
  - BO Wire
  - Park/Neutral Position Switch

- OK**
- PROBLEM CAUSE**
- PY Wire
  - Cruise Control Lockout Relay

**Test C**

R150001

1C

**Z121**  
Cruise Control  
ECU

**CONDITIONS**

- Ignition Switch  
*Position: 0*
- Cruise Control Switch  
*On*

**RESULTS**

- Steering Wheel Cruise Switches  
**SET/ACCEL Switch**

<i>On = BAT VOLT</i>
<i>Off = 0V</i>

- OK**
- PROBLEM CAUSE**
- RW, W, GR Wire
  - WY, PB Wire
  - Rotary Coupler
  - Steering Wheel Cruise Switches

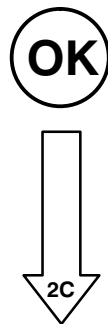

R150001

1C

2C

**CONDITIONS**

- Ignition Switch  
*Position: II*

**RESULTS**

- Brake Pedal  
*BAT VOLT = Depressed*  
*0V = Released*

**Z121  
Cruise Control  
ECU**



**PROBLEM CAUSE**

- GP Wire
- F1 Fuse
- GO Wire
- Stop Lamp Switch

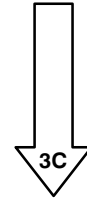

R150001

3C

**CONDITIONS**

- Ignition Switch  
*Position: 0*

**RESULTS**

*0-1 Ω*

**Z121  
Cruise Control  
ECU**



**PROBLEM CAUSE**

- B Wire

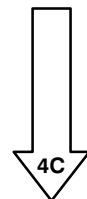

R150001

**3C**

**4C**

**CONDITIONS**

- Ignition Switch  
*Position: II*
- Cruise Control Switch  
*On*

**RESULTS**

- Steering Wheel Cruise Switches  
RES/DECEL Switch  
*Off = 0V*  
*On = BAT VOLT*

**Z121  
Cruise Control  
ECU**



**PROBLEM CAUSE**

- UW, YB Wire
- WY, W Wire
- Rotary Coupler
- Steering Wheel Cruise Switches

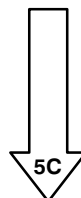

R150001

**5C**

**CONDITIONS**

- Ignition Switch  
*Position: II*

**RESULTS**

- Right rear wheel on ground
- Rotate left rear wheel  
*= 0V - BAT VOLT*

**Z121  
Cruise Control  
ECU**



**PROBLEM CAUSE**

- YK Wire

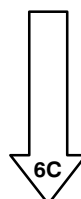

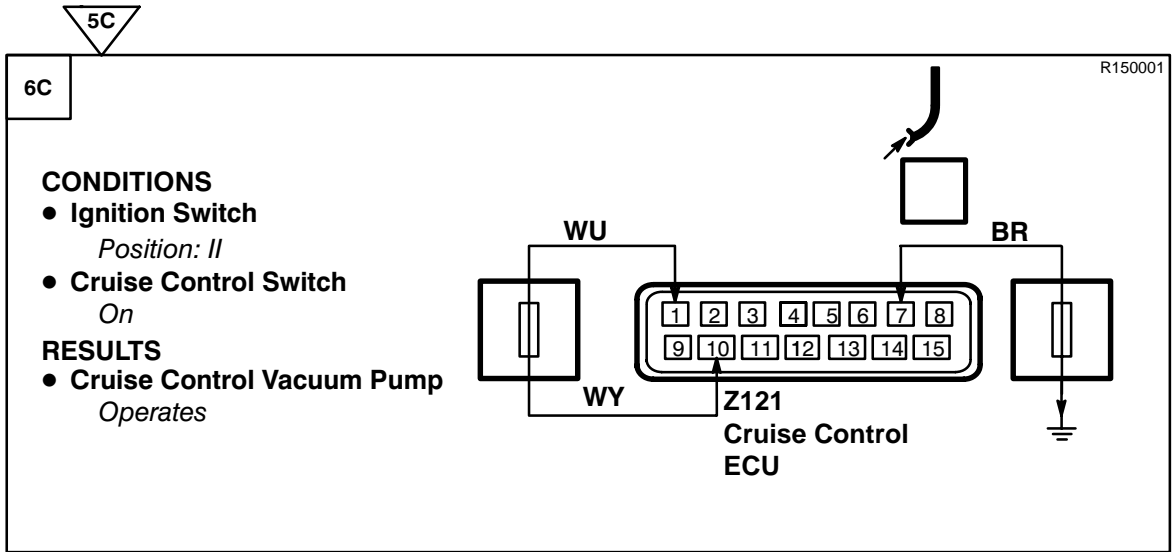

GO TO TEST D

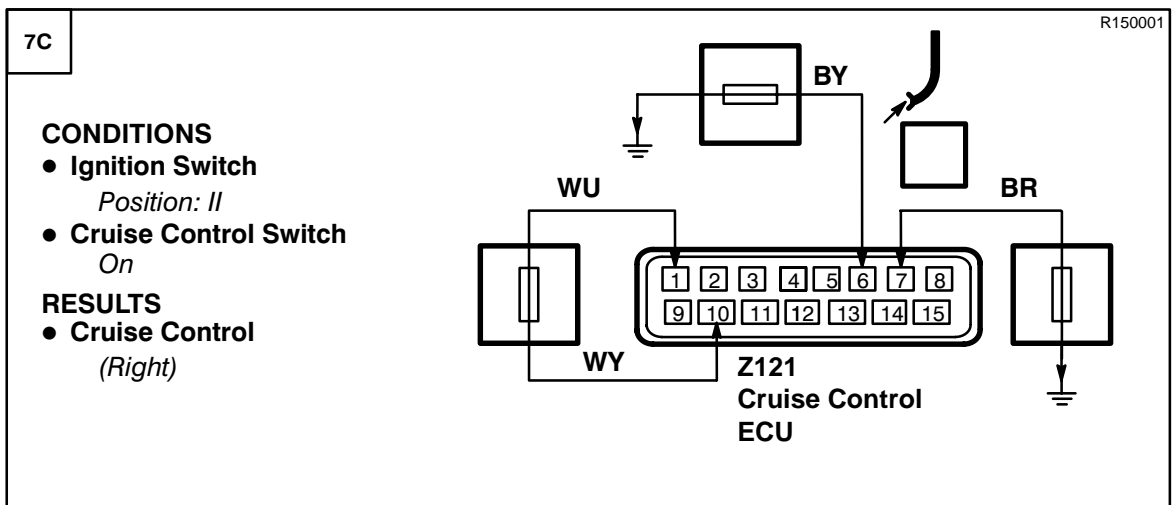
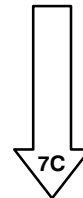

GO TO TEST D



**PROBLEM CAUSE**  
- Cruise Control  
ECU

Test D

R030023

1D

**CONDITIONS**

- Ignition Switch  
*Position: II*
- Cruise Control Switch  
*On*

**RESULTS**  
*BAT VOLT*

**M103**  
Cruise Control  
Vacuum Pump

~~OK~~ **PROBLEM CAUSE**  
- WU Wire

OK

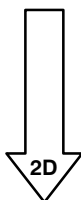

R030031

2D

**CONDITIONS**

- Ignition Switch  
*Position: 0*

**RESULTS**  
• Cruise Control Vacuum Pump  
*Operates*

**M103**  
Cruise Control  
Vacuum Pump

~~OK~~ **PROBLEM CAUSE**  
- BR Wire  
- Cruise Control  
Vacuum Pump

OK

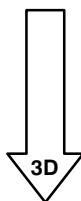

**B5 ETM**

**DISCOVERY**

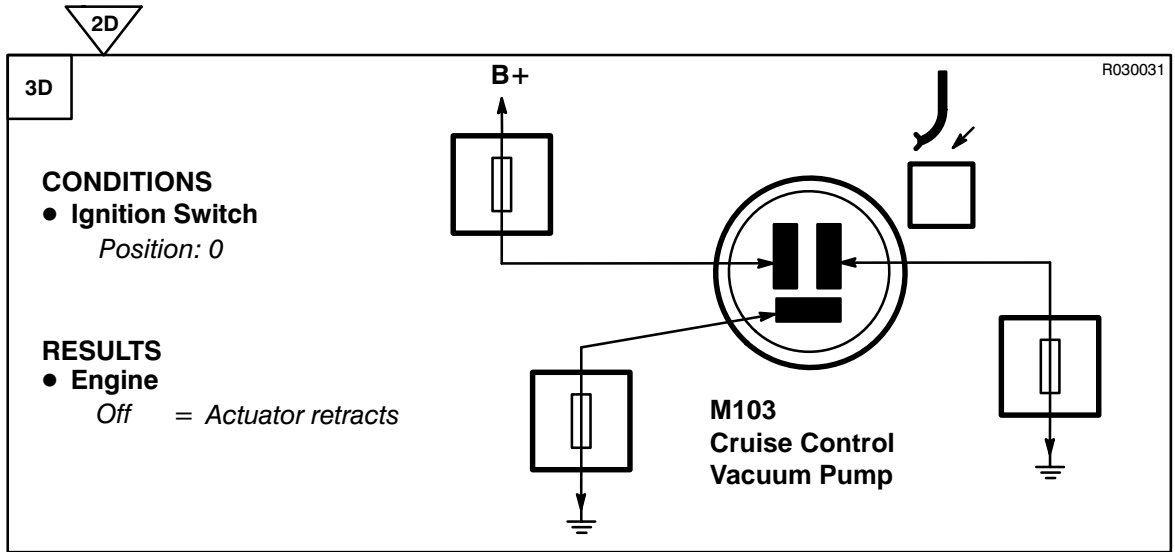

**PROBLEM CAUSE**

- Vacuum leak or restriction
- Brake Switch Vent Valve
- Cruise Control Vacuum Pump



**PROBLEM CAUSE**

- BY Wire



**CIRCUIT OPERATION****Selector Interlock**

When the gear selector is in the park position, the solenoid inside the Transmission Range Selector Switch (Z110) is de-energized and prevents the selector from being moved into another gear. To free the selector, the Ignition Switch (X134) must be in position II and the brake pedal must be depressed. When this occurs, voltage from Fuse F1 is applied to the Transmission Range Selector through the closed Stop Lamp Switch (X168). The solenoid inside the Transmission Range Selector Switch is grounded at E201 through the selector switch, the KS wire and the B wire. The solenoid now energizes, freeing the selector.

**Ignition Key Interlock**

On vehicles equipped with the interlock safety feature the vehicle must be in park and the transfer case in high or low gear before the key can be removed from the ignition. If the gear selector or transfer gear is out of gear, the key must be cycled before removal.

If the vehicle is not in park, voltage from Fuse F12 is applied to the Key Barrel Switch (X230) through the closed contacts of the Transmission Range Selector Switch (Z110). When the ignition switch is placed in the 0 position, the Key Barrel Switch (X230) closes to energize the solenoid and prevent key removal.

If the key is in the ignition and the transfer box is in the neutral position, Interlock Relay 1 (K153) is de-energized since the relay coil is not grounded by the Transfer Box Position Switch (X175). When the relay is de-energized, voltage is applied to the Key Barrel Switch (X230) through the relay's switch contacts and the Key-In Switch (X229) causing the solenoid to energize and prevent key removal.

If the Transfer Box is in the "H" or "L" position, the Interlock Relay 1 (K153) is energized, since the relay coil is grounded by the Transfer Box Position Switch (X175). When the relay is energized, voltage to the Key Barrel Switch (X230) is interrupted. The Ignition Key Lock Solenoid (K191) is then disabled, allowing removal of the key.

**Transfer Box Interlock**

The Transfer Box Interlock safety feature is designed to prevent the transfer case shifter from being shifted out of "H" or "L" unless the vehicle's gear selector is in the neutral position.

When the gear selector is placed in the neutral position, voltage is applied to the Interlock Relay 2's coil through the Transmission Range Selector Switch (Z110). The relay's coil is grounded through the Park/Neutral Position Switch (X167).

Interlock Relay 2 now energizes and applies voltage from Fuse F13 to the Transfer Box Solenoid (K154). When the Transfer Box Solenoid (K154) is energized the transfer box shifter can be operated.

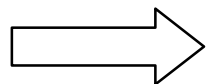
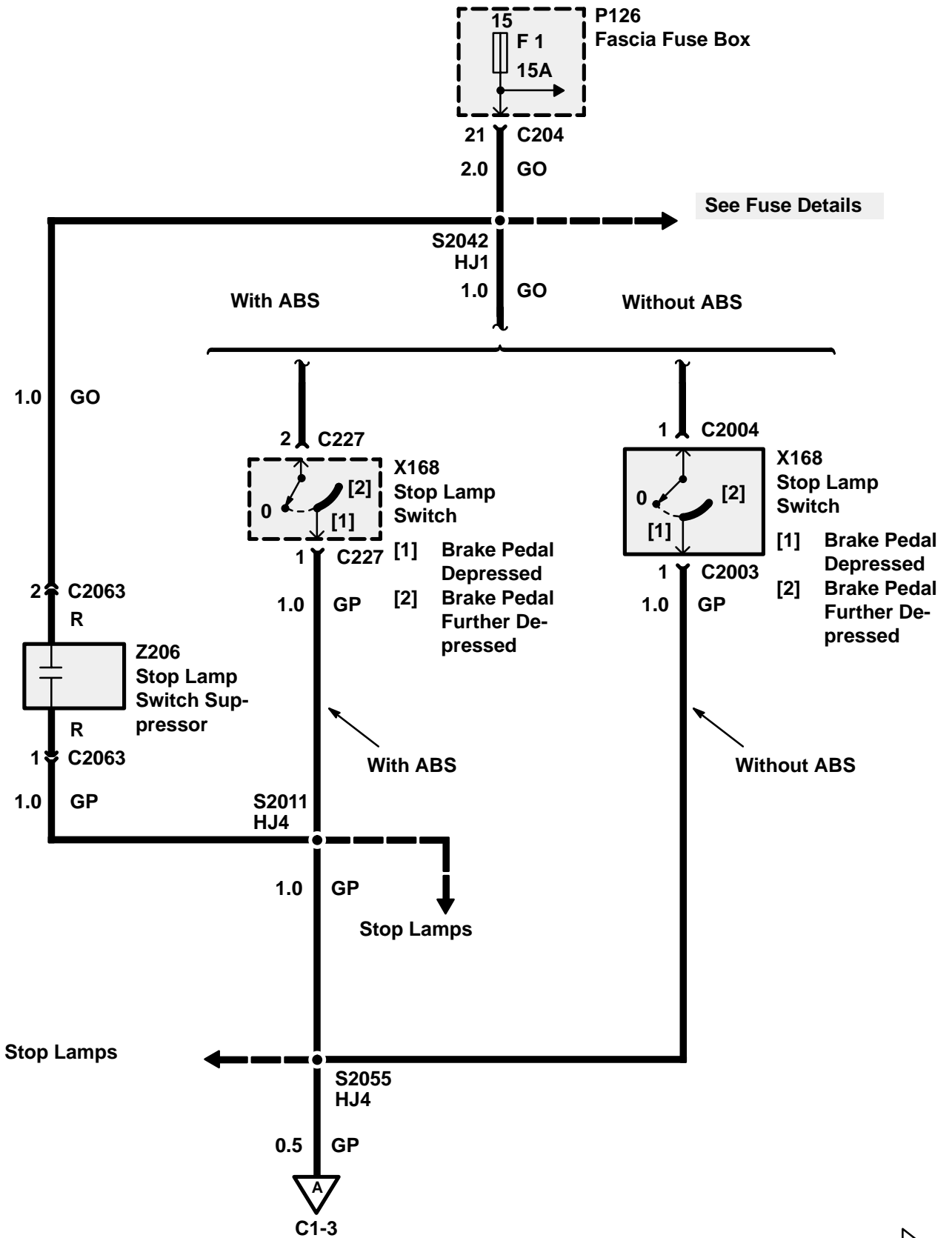

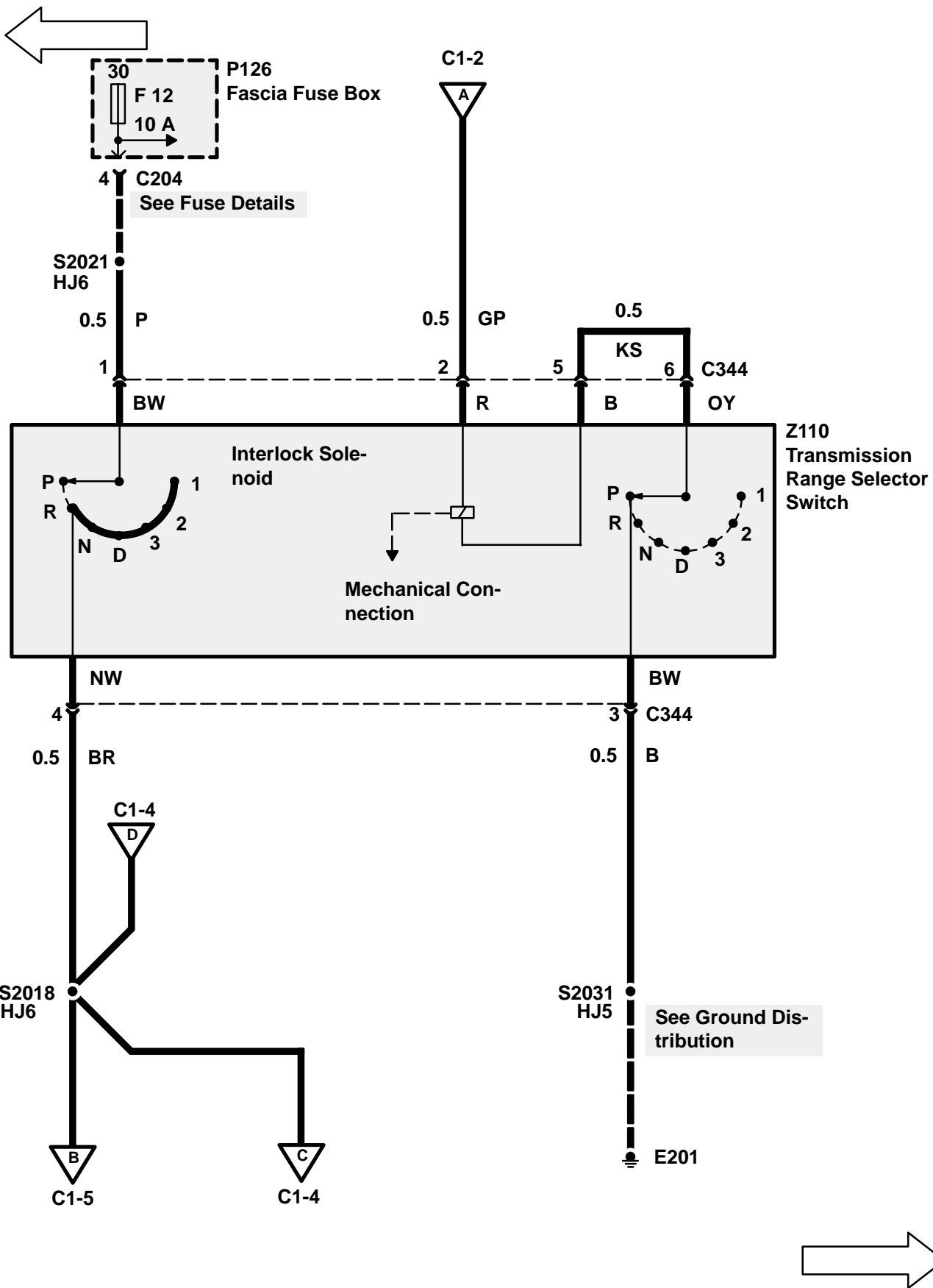



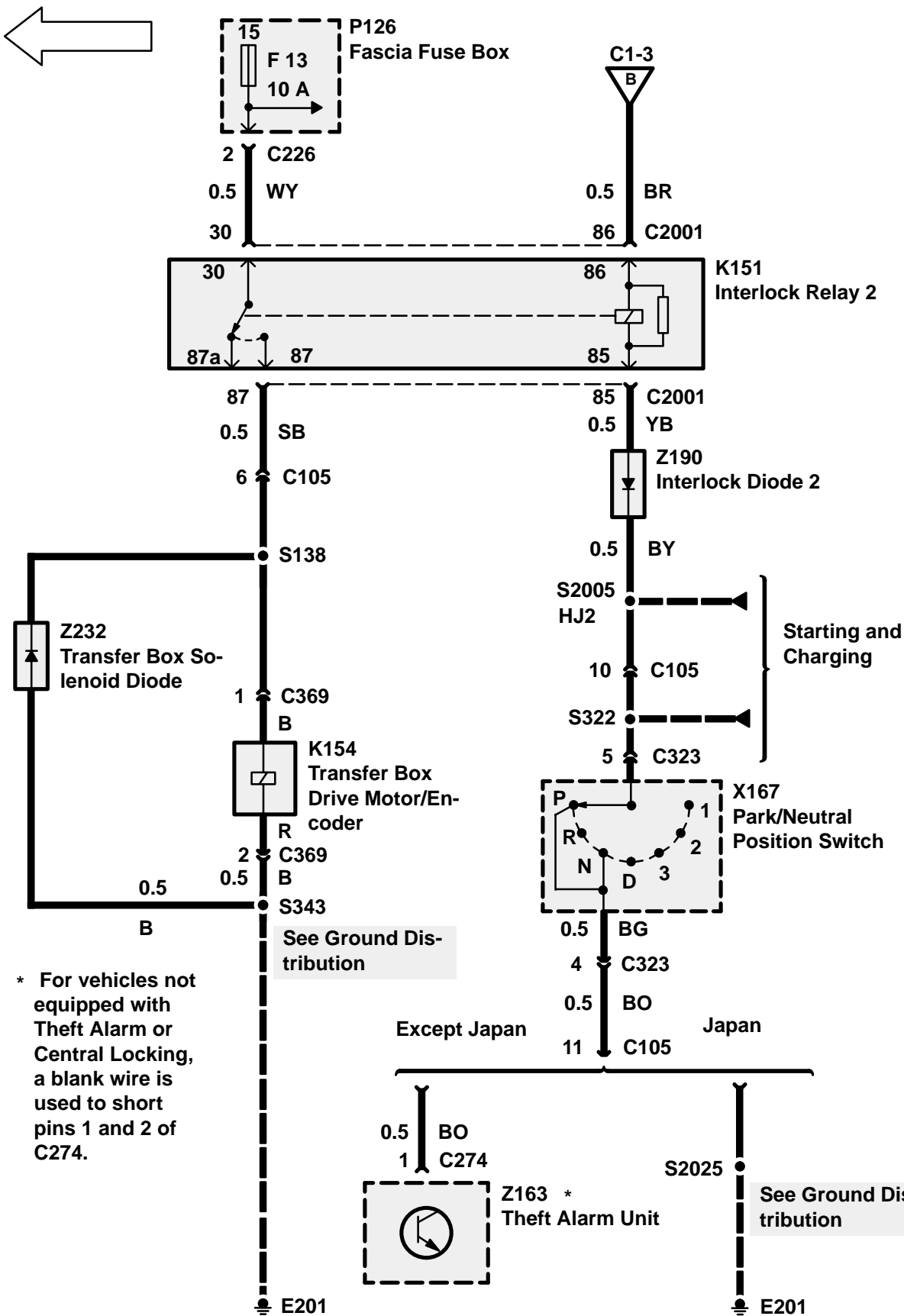

**SYSTEM DIAGNOSIS**

3. If the transmission range selector cannot be shifted out of park, do Test A.
4. If the ignition key cannot be removed with the transmission range selector in park and the transfer box is in "H" or "L", do Test B.
5. If the transfer box can be shifted out of "H" or "L" while in any gear except neutral, do Test C.
6. If the ignition key can be removed with the transmission range selector in any gear except park or with the transfer box in the neutral position, do Test D.
7. If the transfer box cannot be shifted into "N", "H", or "L", with the ignition key inserted and gear selector in "N", do Test F.

**Test A**

1A

R060016

**CONDITIONS**

- Ignition Switch  
*Position: II*

**RESULTS**

- Brake Pedal  
*BAT VOLT= Depressed*
- Brake Pedal  
*0V= Released*

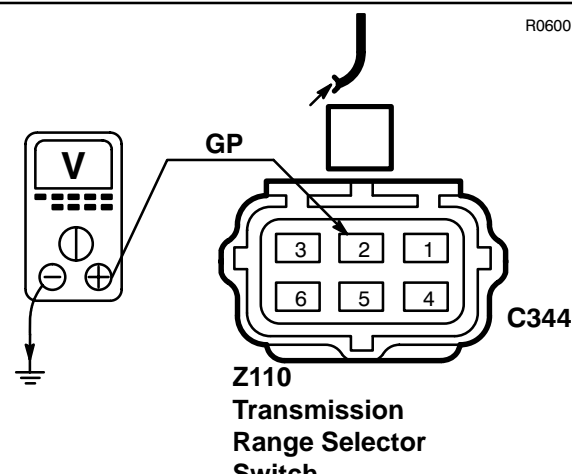

**Z110**  
Transmission  
Range Selector  
Switch



**PROBLEM CAUSE**

- GP Wire
- GO Wire
- F1 Fuse
- Stop Lamp Switch

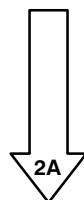

2A

R060016

**CONDITIONS**

- Ignition Switch  
*Position: 0*

**RESULTS**

*Less than 1 ohm*

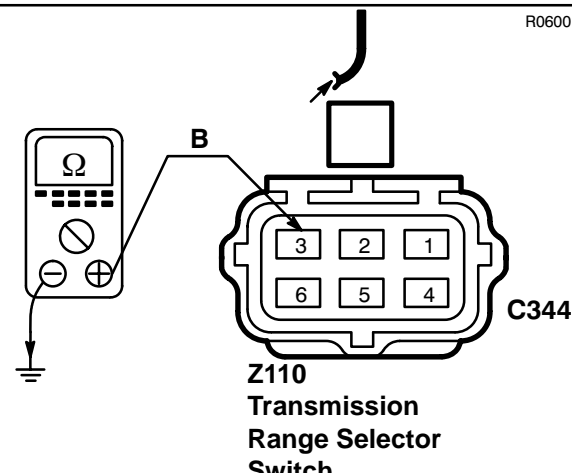

**Z110**  
Transmission  
Range Selector  
Switch



**PROBLEM CAUSE**

- B Wire

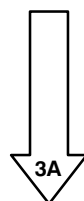

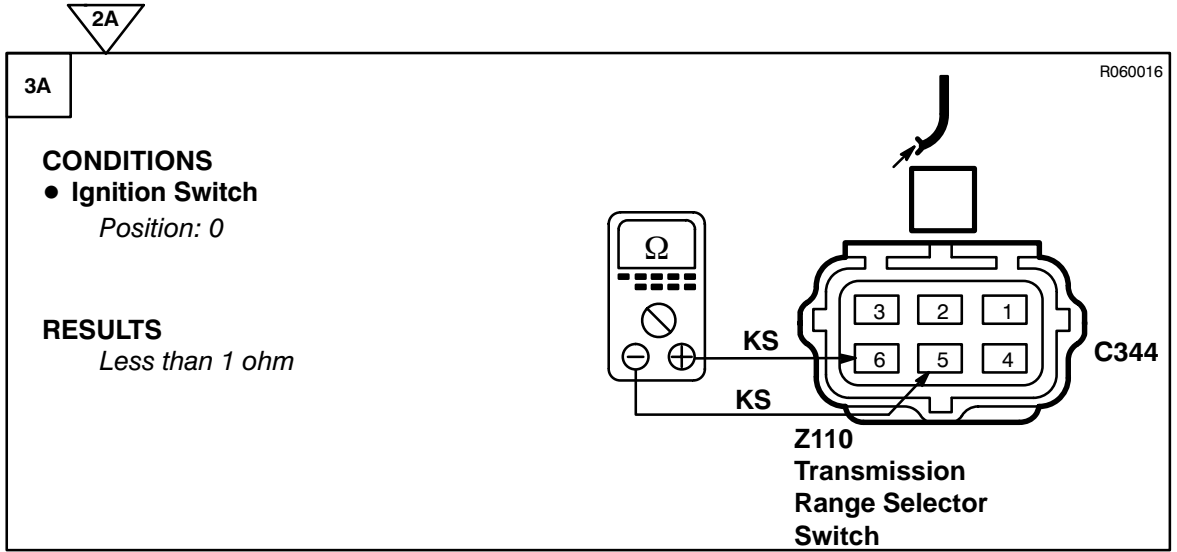

~~OK~~ **PROBLEM CAUSE**  
- KS Wire

OK

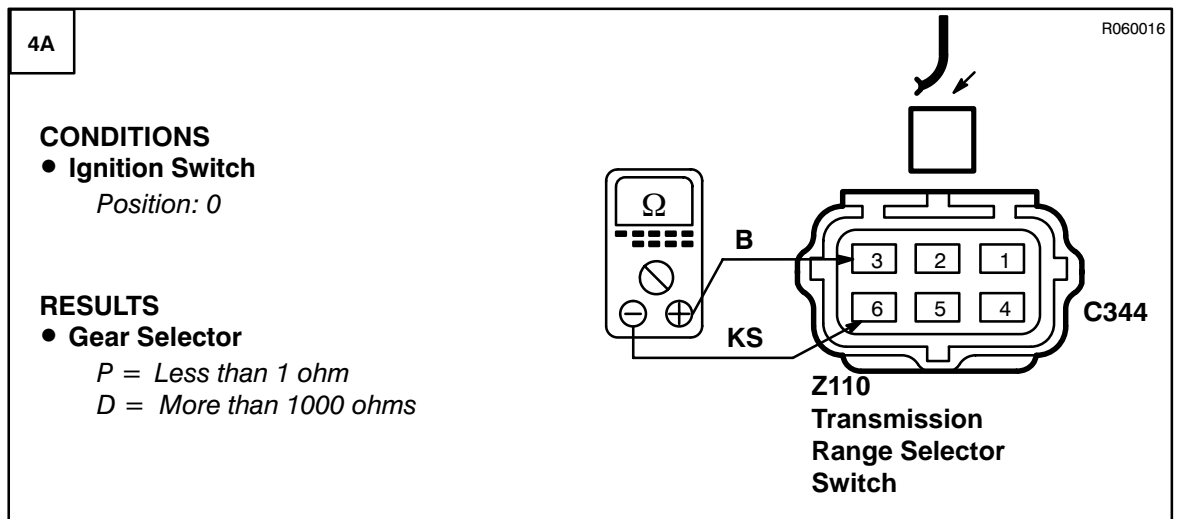
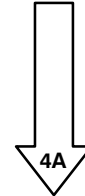

~~OK~~ **PROBLEM CAUSE**  
- Microswitch (Gear Selector)

OK **PROBLEM CAUSE**  
- Interlock Solenoid



Test B

1B R020022

**CONDITIONS**

- Ignition Switch  
*Position: 0*
- Gear Selector  
*P*
- Transfer Box Position Switch  
*H or L*

**RESULTS**  
*0V*

**K191  
Ignition Key  
Lock Solenoid**

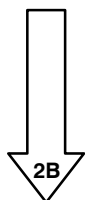

**PROBLEM CAUSE**  
- Ignition Key  
Lock Solenoid

2B R060016

**CONDITIONS**

- Ignition Switch  
*Position: 0*

**RESULTS**

- Gear Selector  
*P = More than 10K ohms*

**Z110  
Transmission  
Range Selector  
Switch**



**PROBLEM CAUSE**  
- Transmission  
Range Selector  
Switch

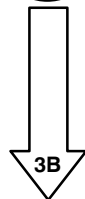

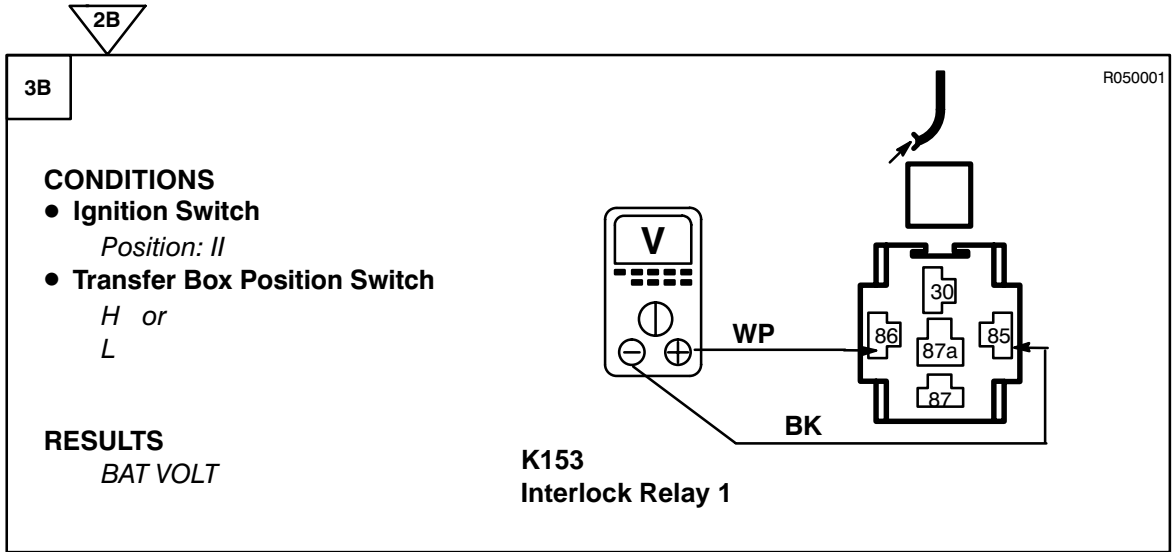

**PROBLEM CAUSE**

- BK, WP, B Wire
- Key-In Switch
- Transfer Box Position Switch



**PROBLEM CAUSE**

- Interlock Relay 1

### Test C

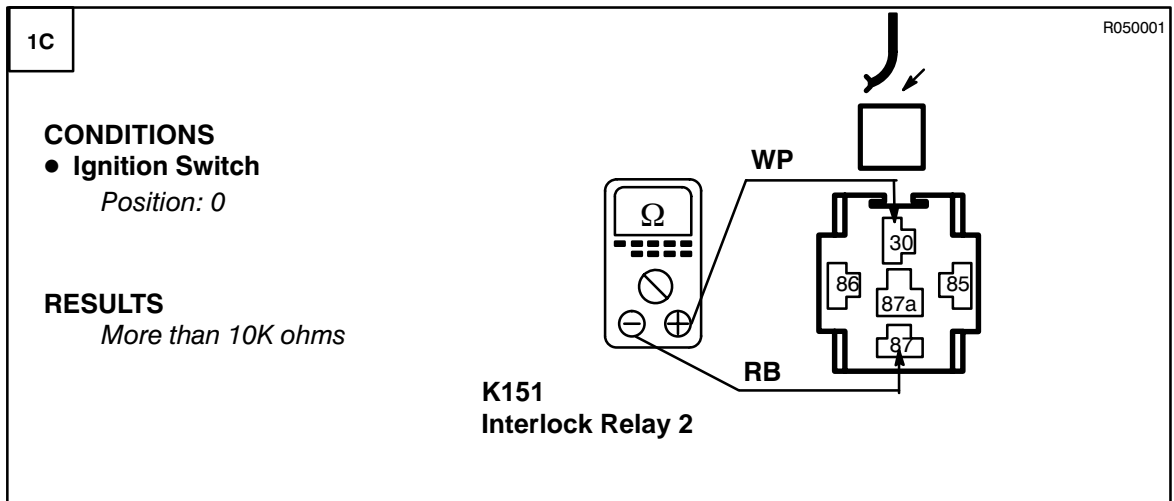

**PROBLEM CAUSE**

- Interlock Relay 2



**PROBLEM CAUSE**

- BY, YB Wire
- Transfer Box Drive Motor/Encoder
- Park/Neutral Position Switch

**Test D**

1D

R020022

**CONDITIONS**

- Ignition Switch  
*Position: II*
- Gear Selector  
*P*

**RESULTS**

- Transfer Box Position Switch  
*N = BAT VOLT*

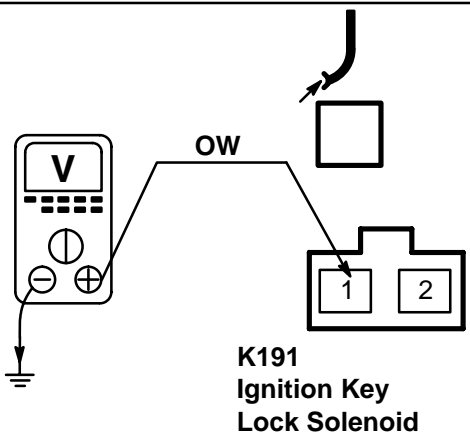

K191  
Ignition Key  
Lock Solenoid



GO TO TEST E

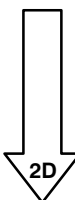

2D

R020022

**CONDITIONS**

- Ignition Switch  
*Position: II*
- Transfer Box Position Switch  
*H or L*

**RESULTS**

- Gear Selector  
*P = 0 VOLTS*  
*R, N, D, 3, 2, 1 = BAT VOLT*

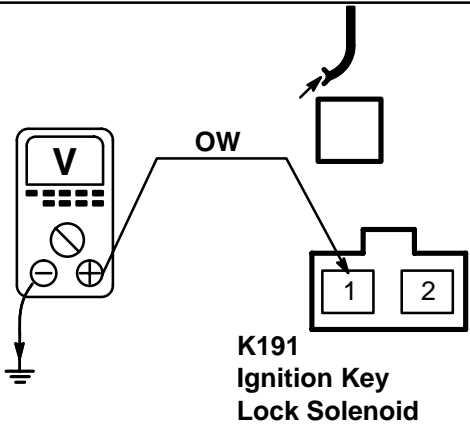

K191  
Ignition Key  
Lock Solenoid



**PROBLEM CAUSE**

- BR Wire
- OW Wire
- Transmission Range Selector Switch
- Key – Barrel Switch



**PROBLEM CAUSE**

- Ignition Key  
Lock Solenoid

### Test E

R050001

1E

**CONDITIONS**

- Ignition Switch  
*Position: II*

**RESULTS**  
*BAT VOLT*

**K153  
Interlock Relay 1**

**OK** PROBLEM CAUSE

- WP Wire
- Key-In Switch

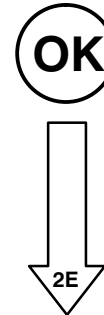

R050001

2E

**CONDITIONS**

- Ignition Switch  
*Position: 0*
- Transfer Box Position Switch  
*N*

**RESULTS**  
*More than 10K ohms*

**K153  
Interlock Relay 1**

**OK** PROBLEM CAUSE

- BK Wire
- Transfer Box  
Position Switch

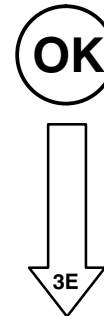

2E

3E

R050001

**CONDITIONS**

- Ignition Switch  
*Position: 0*
- Gear Selector  
*P*

**RESULTS**  
*Ignition key cannot be removed*

**K153**  
Interlock Relay 1

**OK** PROBLEM CAUSE

- RB Wire
- BR Wire
- Interlock Diode 1

**OK** PROBLEM CAUSE

- Interlock Relay 1

**Test F**

1F

R050001

**CONDITIONS**

- Ignition Switch  
*Position: II*

**RESULTS**

- Gear Selector  
*N = BAT VOLT*

**K151**  
Interlock Relay 2

**OK** PROBLEM CAUSE

- BR Wire
- Transmission Range Selector Switch

**OK**

↓

2F

# C1 ETM

## DISCOVERY

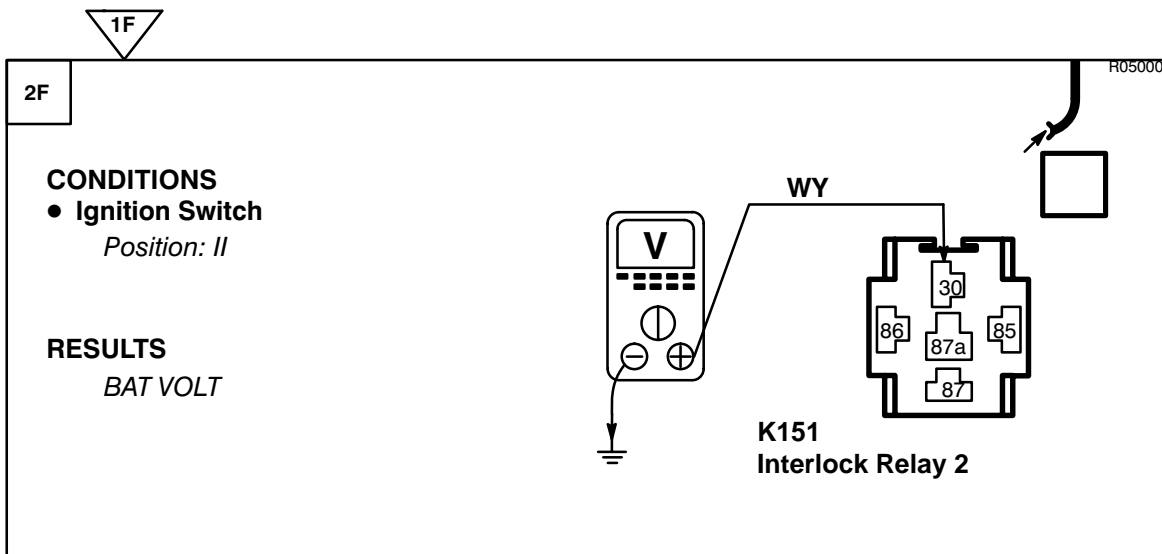

**PROBLEM CAUSE**

- F13 Fuse
- WY Wire

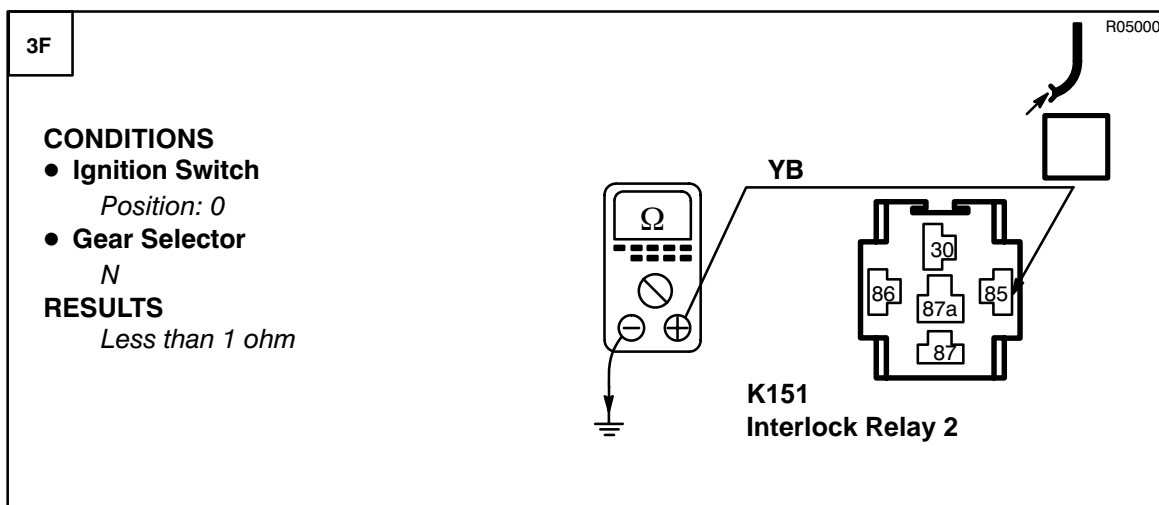
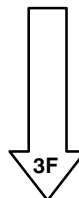

**PROBLEM CAUSE**

- YB, BY, BO Wire
- Interlock Diode 2
- Park/Neutral Position Switch
- Theft Alarm Unit

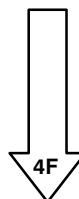

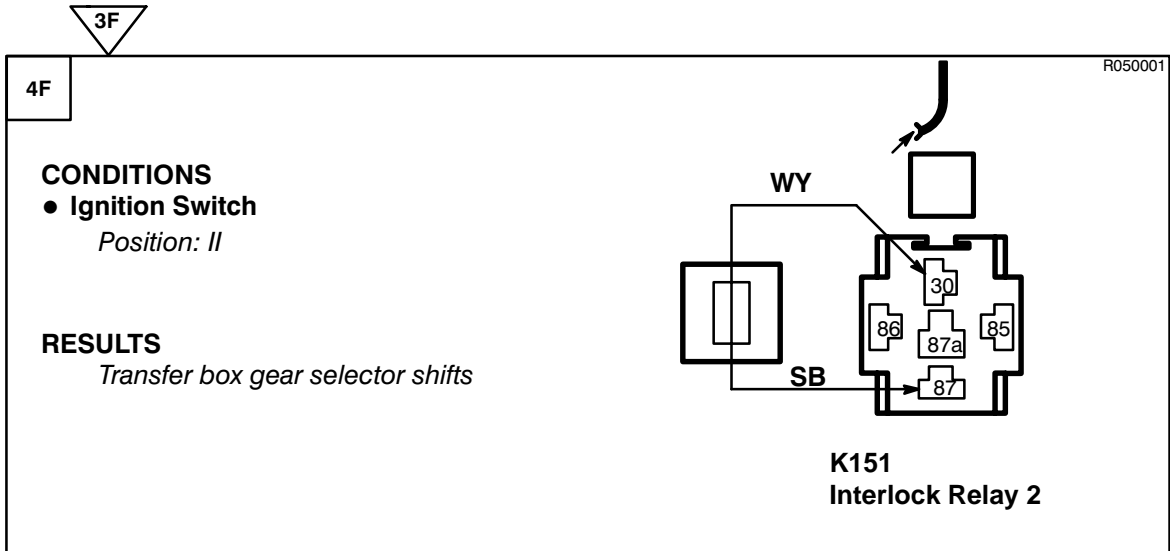

**PROBLEM CAUSE**

- SB Wire
- B Wire
- Transfer Box Drive Motor/Encoder



**PROBLEM CAUSE**

- Interlock Relay 2





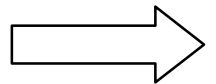
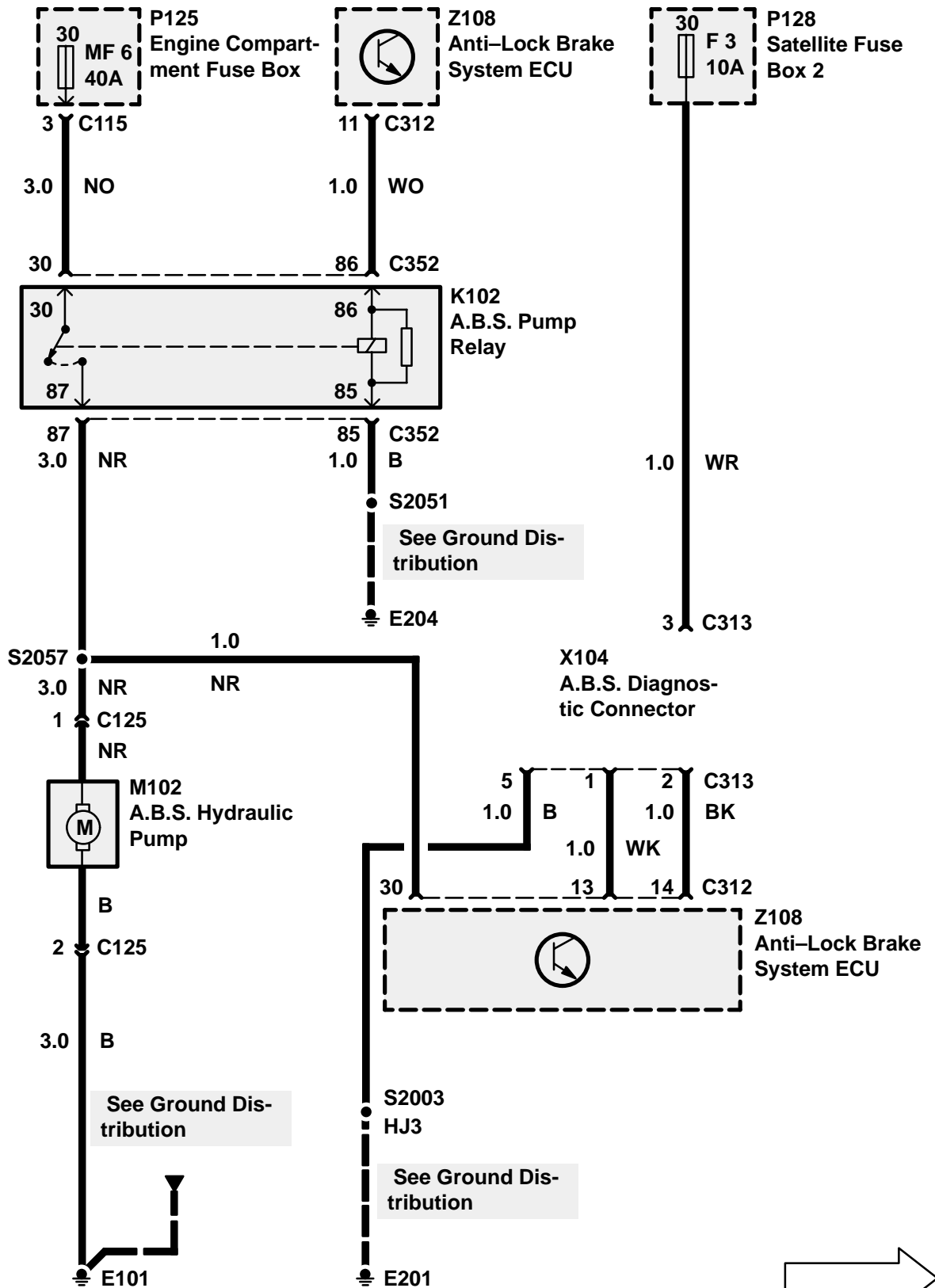
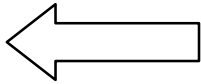

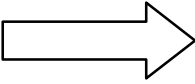
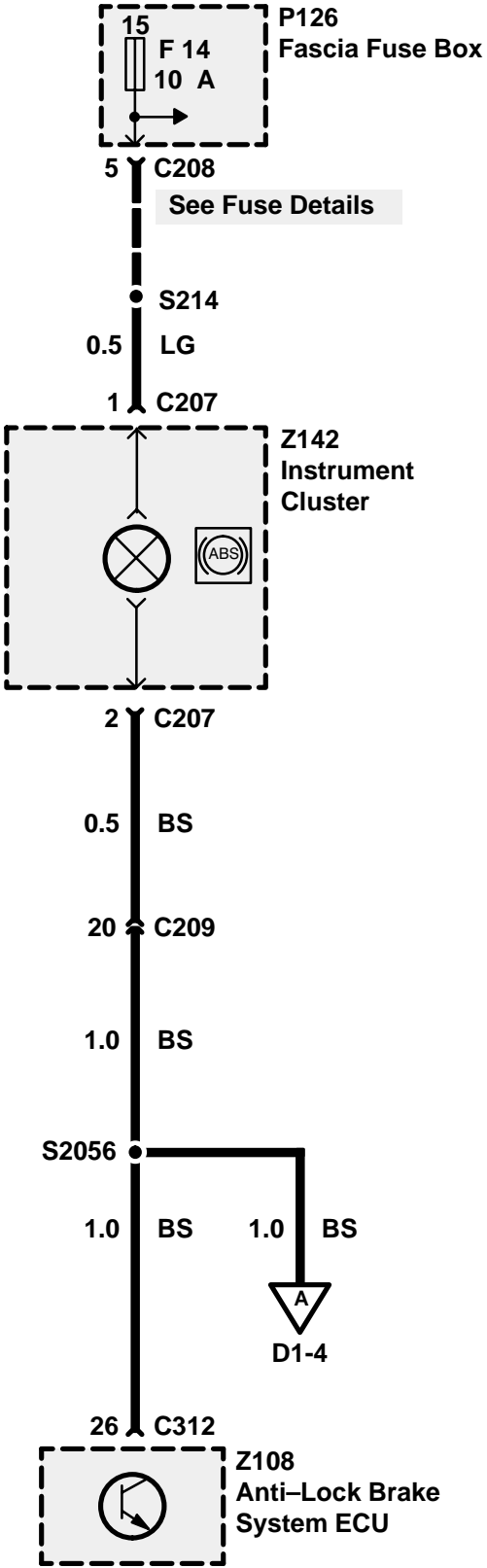
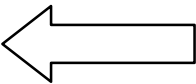

# D1 ETM

## DISCOVERY

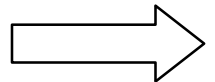
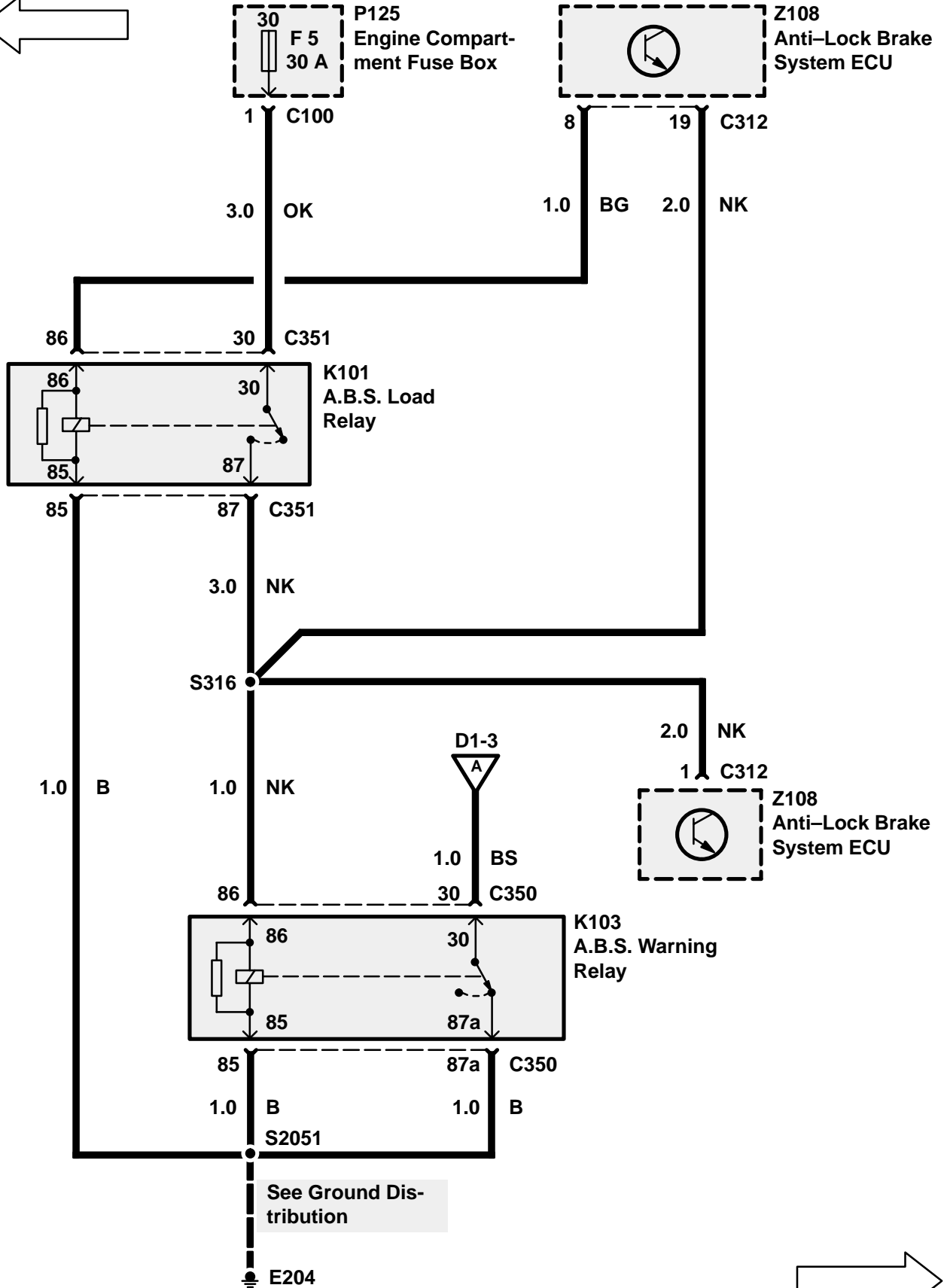

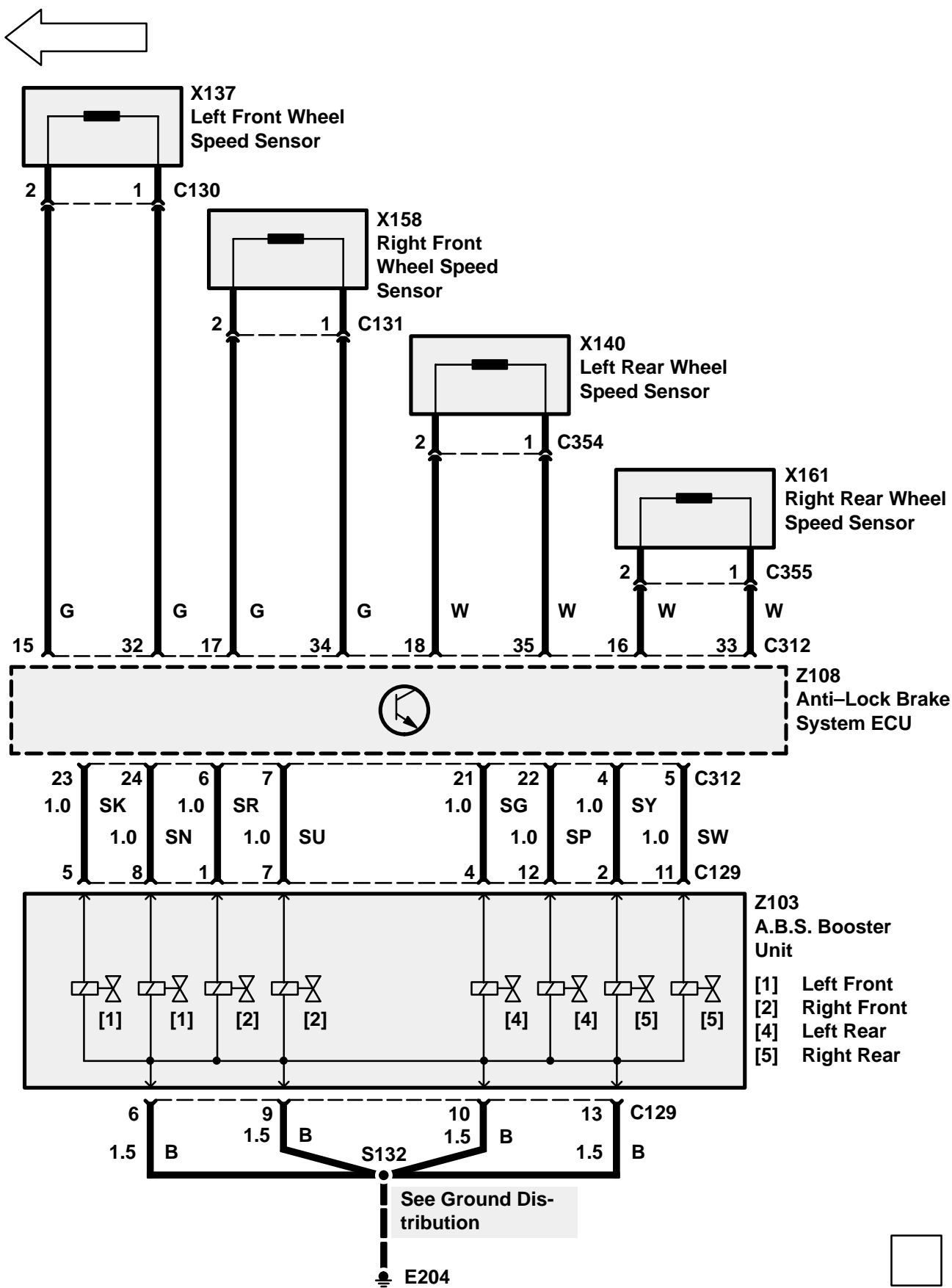

## CIRCUIT OPERATION

### Engine Coolant Temperature Gauge

The Engine Coolant Temperature Gauge Sensor (X114) has approximately 136 ohms resistance when the coolant temperature is low. As coolant temperature increases, the resistance of the sensor decreases. This varying resistance causes the current through the sensor to change and the gauge to register the temperature. When the coolant is hot, the resistance of the sensor is approximately 17 ohms.

### Fuel Gauge

When the fuel tank level is low, the resistance of the fuel gauge sender is approximately 245 ohms. As the fuel level increases, the resistance of the sender decreases, causing the gauge to register the change. When the fuel tank is full, the resistance of the sender is approximately 19 ohms. When the fuel gauge sender's resistance falls below approximately 25 ohms (6 liters/1.5 US gallons), the fuel warning light will illuminate to warn the driver.

### Speedometer

The Vehicle Speed Sensor (X190) sends a signal to the speedometer in the form of voltage pulses. The pulses are filtered by a Vehicle Speed Sensor Buffer inside the speedometer. The voltage alternates between battery voltage and 0 volts 6 times per wheel revolution. The speed sensor signal is also sent to the Cruise Control ECU (Z121), Multifunction Unit (MFU) (Z148) (Persian Gulf States), and the Engine Control Module (Z132).

### Tachometer

The tachometer displays engine speed in rpm. Voltage pulses are taken from the Generator (Z106) and are generated when the engine drive belt turns the Generator pulley. The tachometer responds to the frequency of the voltage pulses, which increases proportionally to that of the engine speed.

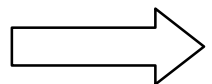
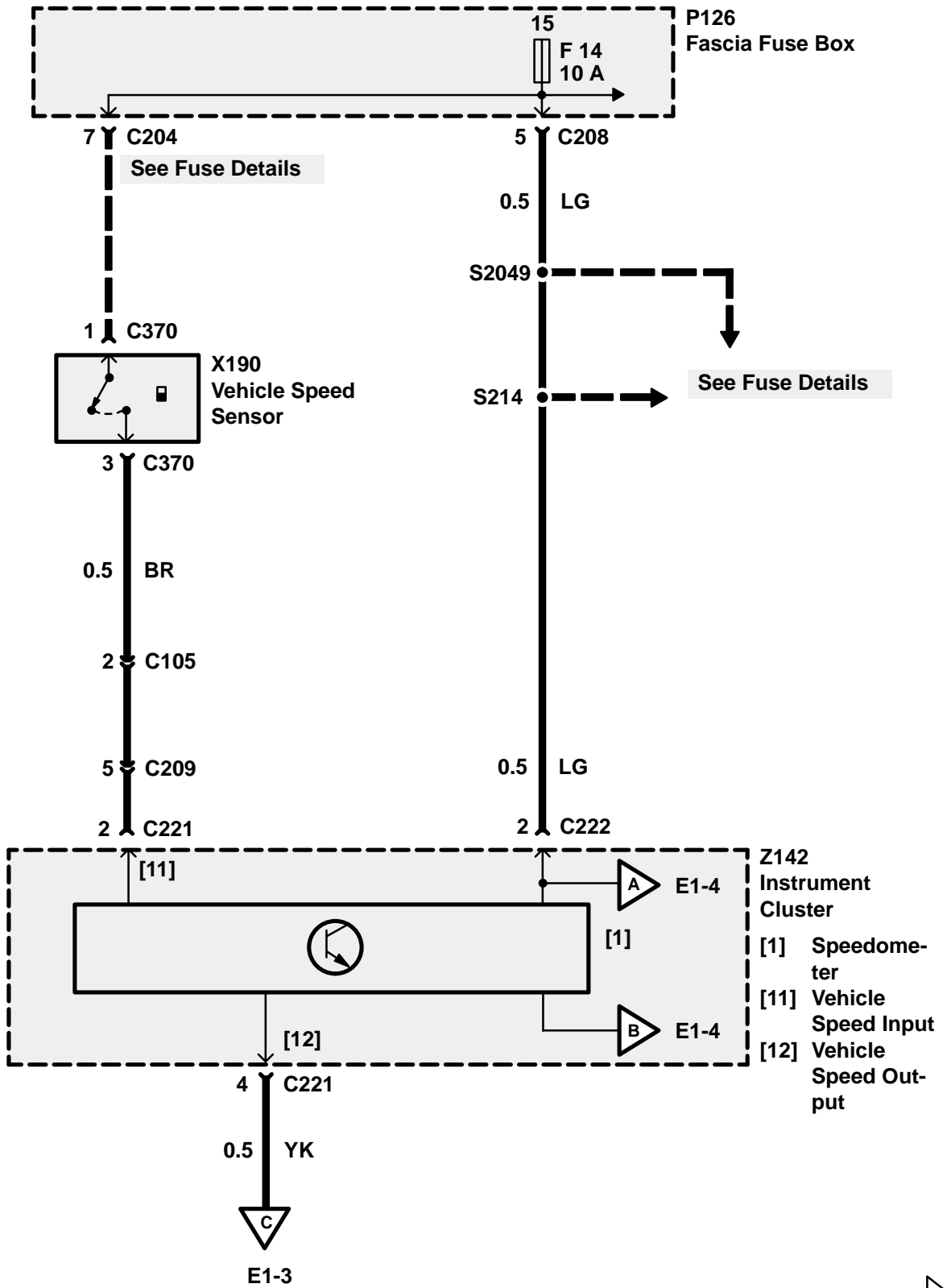

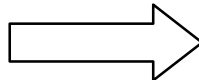
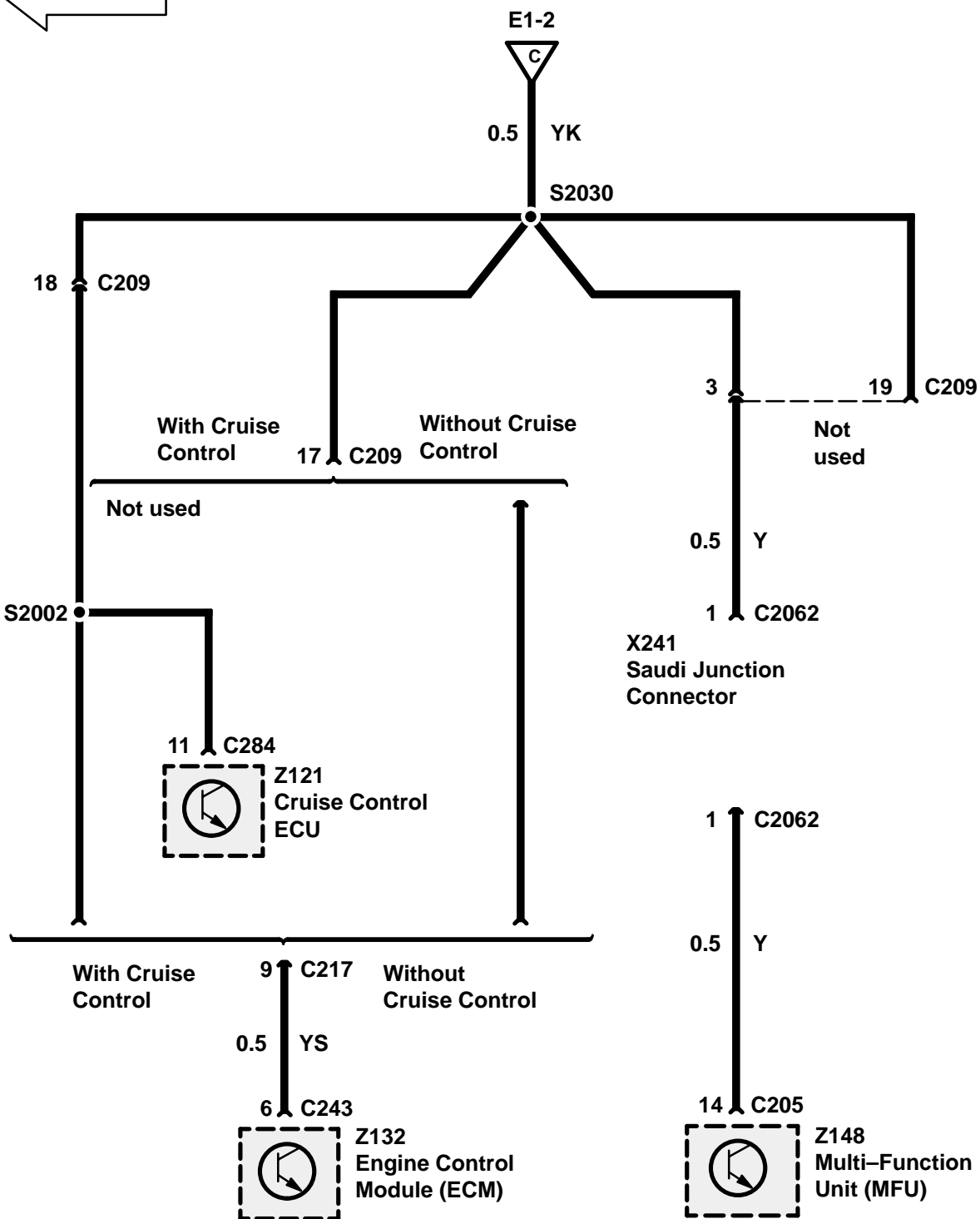
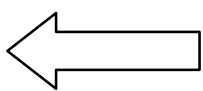

# E1 ETM

## DISCOVERY

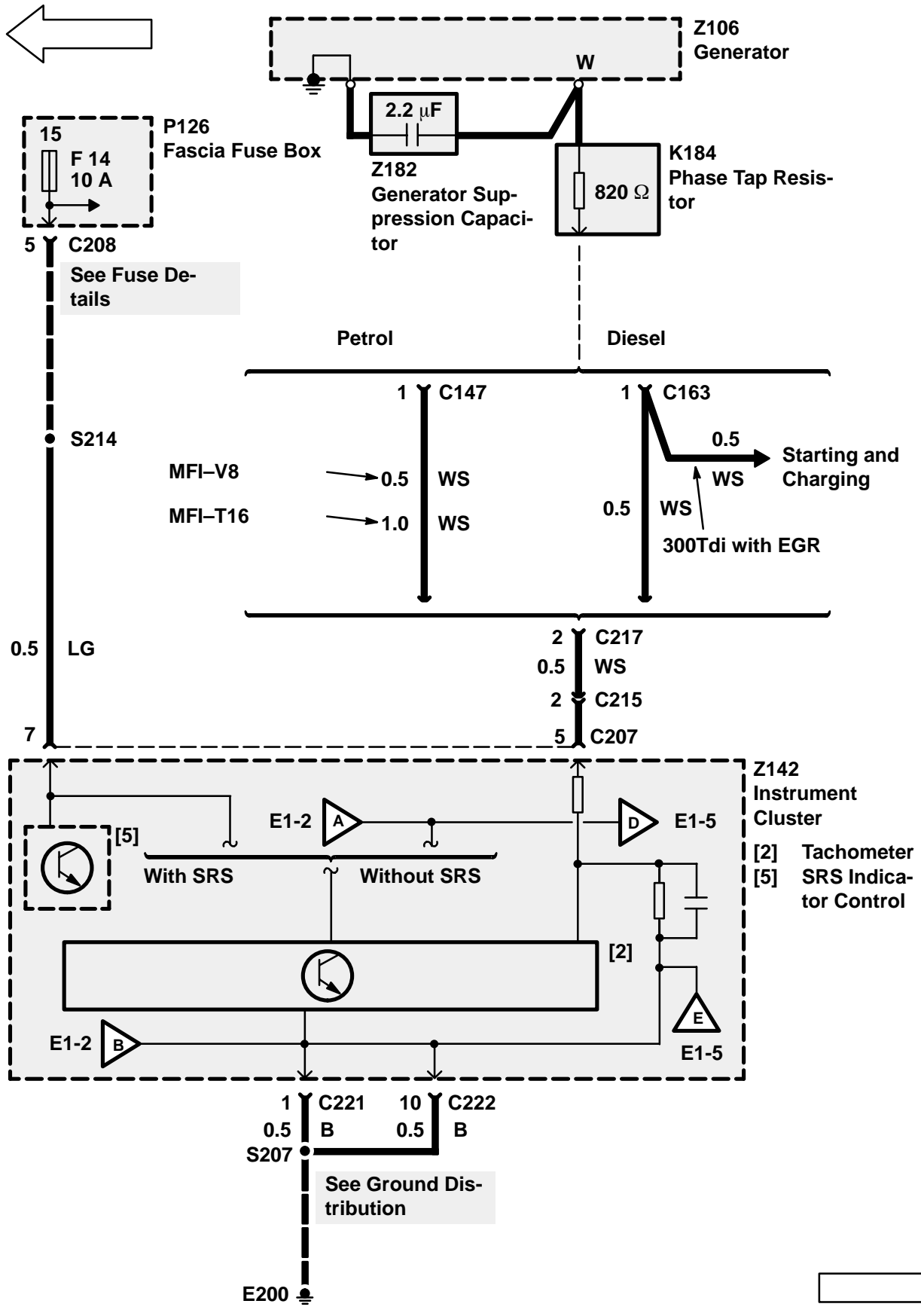



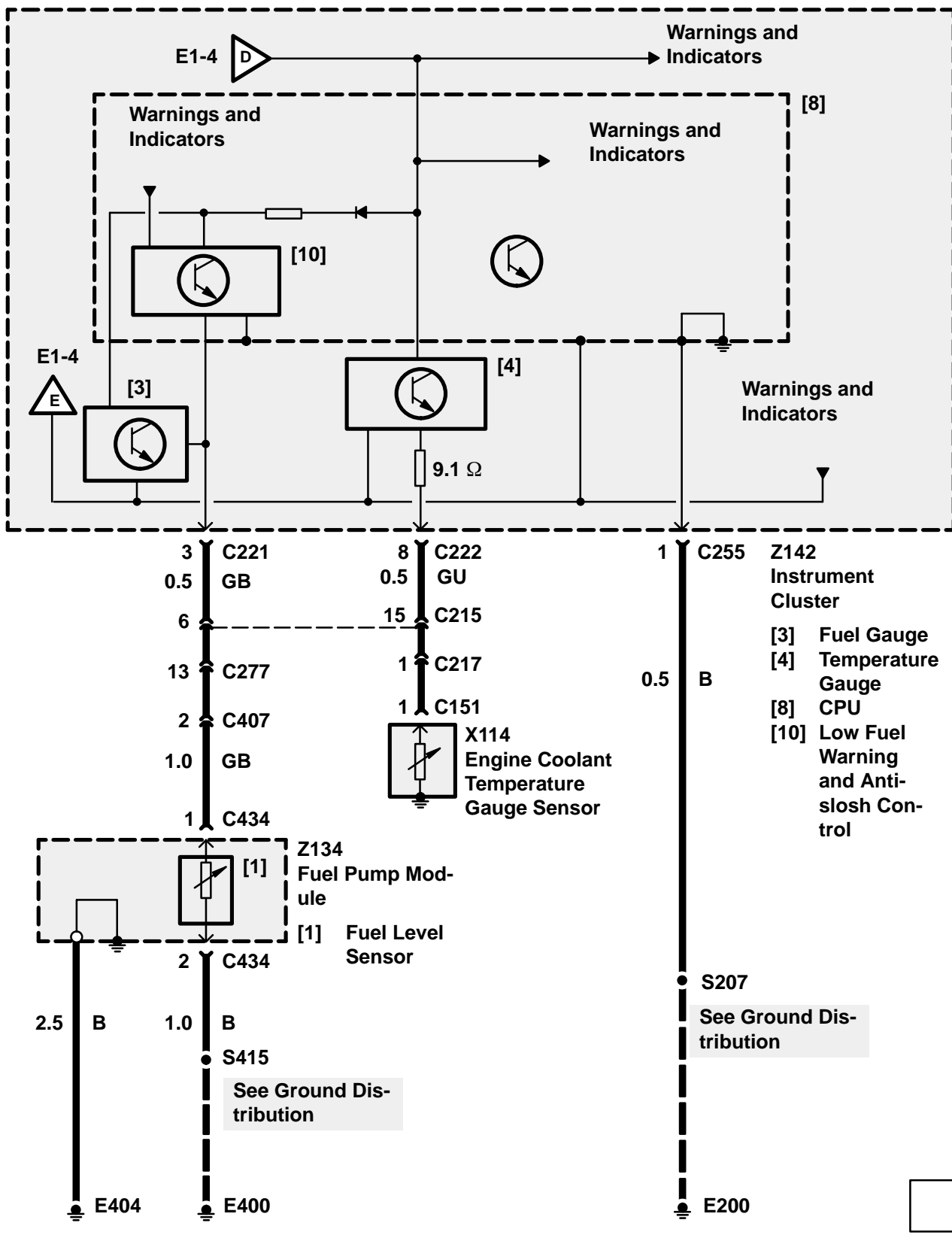
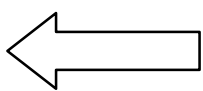

**SYSTEM DIAGNOSIS**

8. If no instruments operate, do Test A.
9. If the coolant temperature gauge reads hot with coolant cool, do Test B.
10. If the coolant temperature gauge reads cool with coolant hot, do Test B.
11. If the fuel gauge reads empty with fuel in the tank, do Test C.
12. If the fuel gauge reads full when the tank is empty, do Test C.
13. If the speedometer does not operate, do Test D.
14. If the tachometer does not operate, do Test E.

Test A

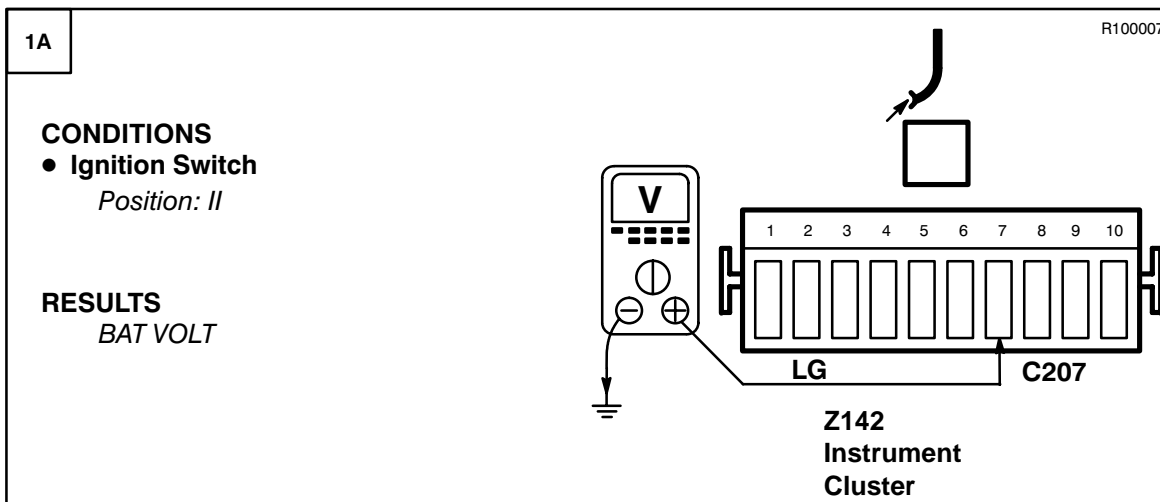

~~OK~~ **PROBLEM CAUSE**  
 - LG Wire  
 - F14 Fuse

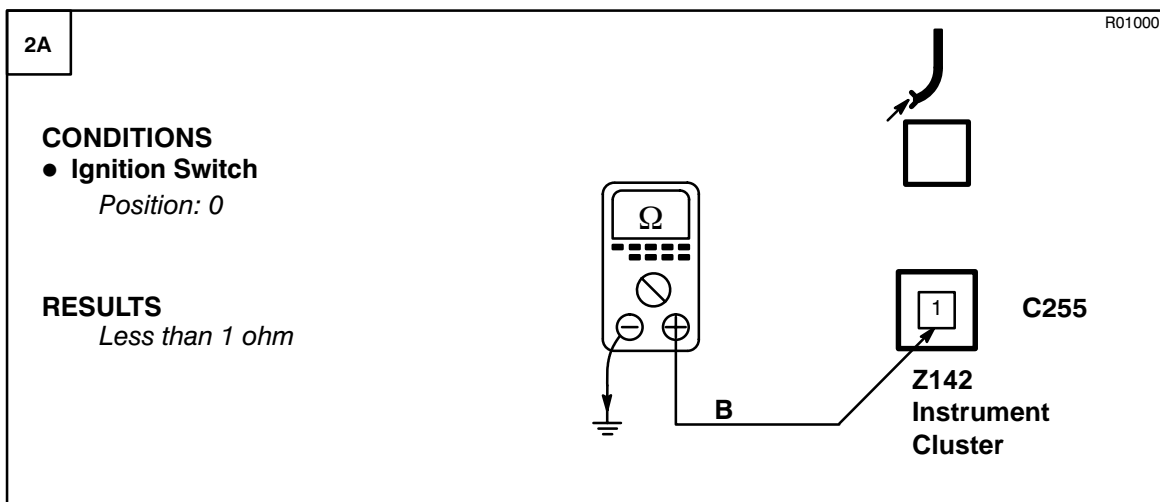
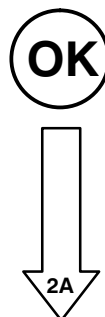

~~OK~~ **PROBLEM CAUSE**  
 - B Wire

**OK** **PROBLEM CAUSE**  
 - Instrument  
 Cluster

### Test B

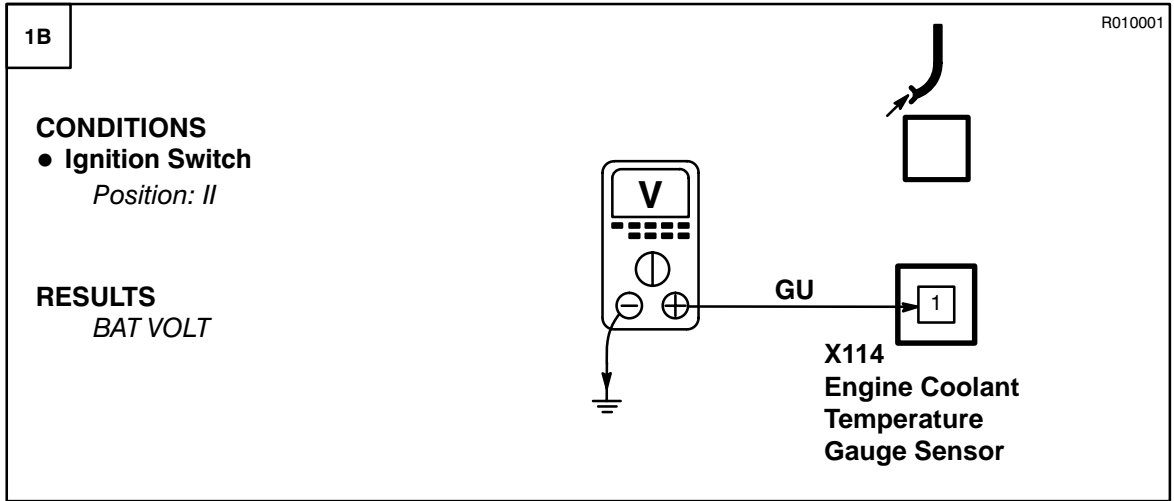

**PROBLEM CAUSE**

- GU Wire
- Instrument Cluster
- Coolant Temperature Gauge



**PROBLEM CAUSE**

- Engine Coolant  
Temperature  
Gauge Sensor

### Test C

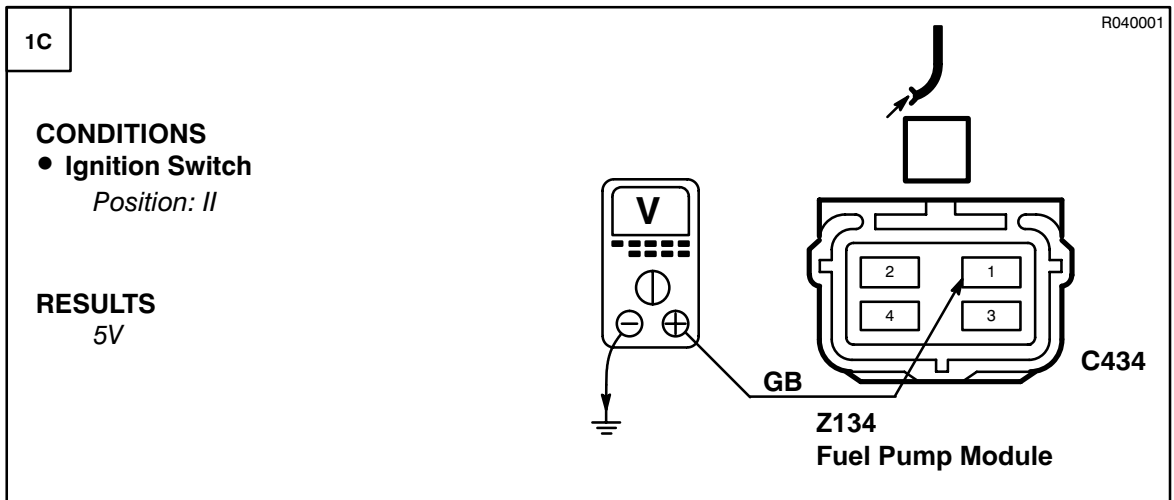

**PROBLEM CAUSE**

- GB Wire
- Instrument Cluster
- Fuel Gauge

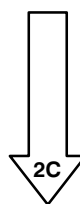

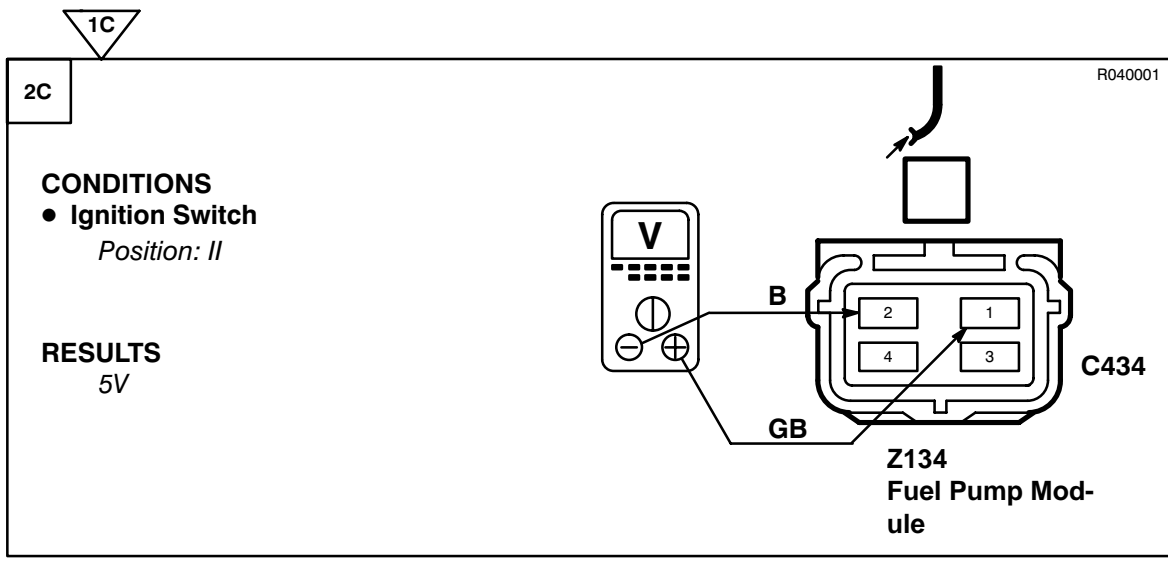

**OK** PROBLEM CAUSE  
- B Wire

**OK** PROBLEM CAUSE  
- Fuel Pump Module

**Test D**

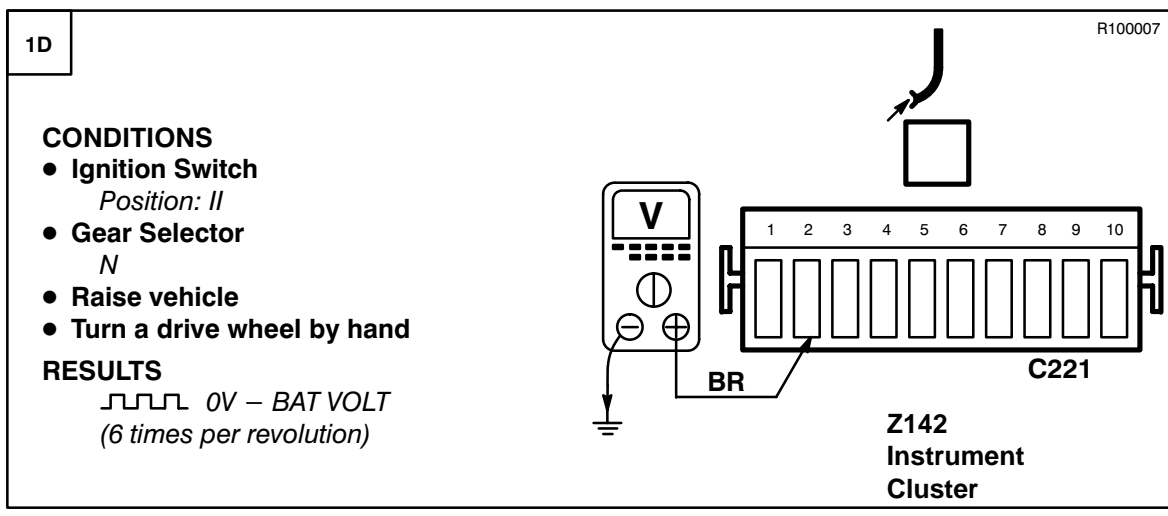

**OK** PROBLEM CAUSE  
- GY Wire  
- BR Wire  
- Vehicle Speed Sensor

**OK** PROBLEM CAUSE  
- Instrument Cluster  
- Speedometer

Test E

R010001

1E

**CONDITIONS**

- Ignition Switch  
*Position: II*

**RESULTS**

- Engine  
*On = 7V*

K184  
Phase Tap Resis-  
tor



- PROBLEM CAUSE**
- Generator
  - Phase Tap Resistor



- PROBLEM CAUSE**
- WS Wire
  - Instrument Cluster
  - Tachometer

**CIRCUIT OPERATION****Charge Warning Light**

The charge warning light receives battery voltage with the Ignition Switch (X134) in position II. This warning light is grounded by the Generator (Z106) if the Generator is not producing normal power output or the Generator stops turning.

**ABS Warning Light**

The ABS warning light receives battery voltage with the Ignition Switch (X134) in position II. It is grounded by the Anti-Lock Brake System ECU (Z108) or the ABS Warning Relay (K103) in the event of an ABS problem.

**Brake Warning Light**

The brake warning light receives battery voltage with the Ignition Switch (X134) in position II. It is grounded by the Brake Fluid Level Switch (X111) when the brake fluid level is low. It may also be grounded when the Handbrake Switch (X191) is closed. On Australian vehicles the brake warning light is grounded by a 3 second timer as a bulb check.

**Oil Pressure Warning Light**

The oil pressure warning light receives battery voltage with the Ignition Switch (X134) in position II. If the engine oil pressure is very low, the Oil Pressure Switch (X149) will apply ground to the warning light.

**Transmission/Transfer Box Oil Temperature Warning Light**

The transmission/transfer box oil temperature warning light is grounded by the Automatic Transmission Oil Temperature Switch (X108) when the temperature of the transmission fluid exceeds 130°C (266°F). The warning light is also grounded by the Transfer Box Oil Temperature Switch (X174) when the temperature of the transfer box fluid exceeds 145°C (266°F). On Australian vehicles the warning light is grounded by a 3 second timer as a bulb check.

**MFI-V8 and 300Tdi with EDC****Malfunction Indicator Lamp (Check Engine)**

The Malfunction Indicator Lamp (Check Engine) is grounded by the Engine Control Module (ECM) (Z132) when a diagnostic trouble code is set.

**Diesel****Glow Plug Indicator**

The Glow Plug Indicator is grounded by the Glow Plug Timer Unit (Z135) to indicate that the Glow Plugs have been activated.

**Hazard Indicator**

If the Hazard Switch (X220) is depressed, a pulsing voltage is applied to the Hazard Indicator which is permanently grounded by ground E200.

**Direction Indicator**

If the Direction Indicator Switch (X116) is turned on, a pulsing voltage is applied from the Flasher Unit (Z128) to the Direction Indicator which is permanently grounded by ground E200.

**Trailer Indicator**

With the Direction Indicator Switch (X116) turned on, the Flasher Unit (Z128) also applies a pulsing voltage to the Trailer Indicator which is permanently grounded by ground E200.

**SRS Indicators**

The SRS Indicators are controlled by the Air Bag Diagnostic Control Module (Z151) and the SRS Indicator Control Circuit of the Instrument Cluster (Z142) to indicate SRS System faults.

**Low Fuel Warning Indicator**

When the fuel gauge sender's resistance falls below approximately 25 Ohms (6 liters/1.5 US gallons), the Low Fuel Warning Indicator will illuminate to warn the driver.

**Main Beam Indicator**

With the Headlamps turned on the Main Lighting Switch (X145), battery voltage is applied to the Main Beam Indicator which is also permanently grounded by ground E200.

**Catalyst Warning Indicator  
(Japan Vehicles Only)**

In case of a catalyst overheat, the catalyst thermocouples send a signal to the Catalyst Warning ECU's which then provide battery voltage to the Catalyst Warning Relay (K172). The relay is energized and provides ground to the Catalyst Warning Indicator. The Catalyst Warning Indicator is also grounded by a 3 second timer as a bulb check.

**Differential Lock Indicator**

The Differential Lock Indicator receives battery voltage with the Ignition Switch (X134) in position II. It is grounded by the Differential Lock Switch (X238) when the Differential is locked.

**Fasten Seat Belt Indicator  
(Except Japan Vehicles Only)**

The Fasten Seat Belt Indicator receives battery voltage with the Ignition Switch (X134) in position II. The indicator is also grounded through the Multi-Function Unit (MFU) (Z148) and the Driver's Seat Buckle Switch (X120). If the Driver's Seat Belt is buckled the Driver's Seat Belt Buckle Switch opens and the Indicator turns off.



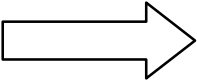
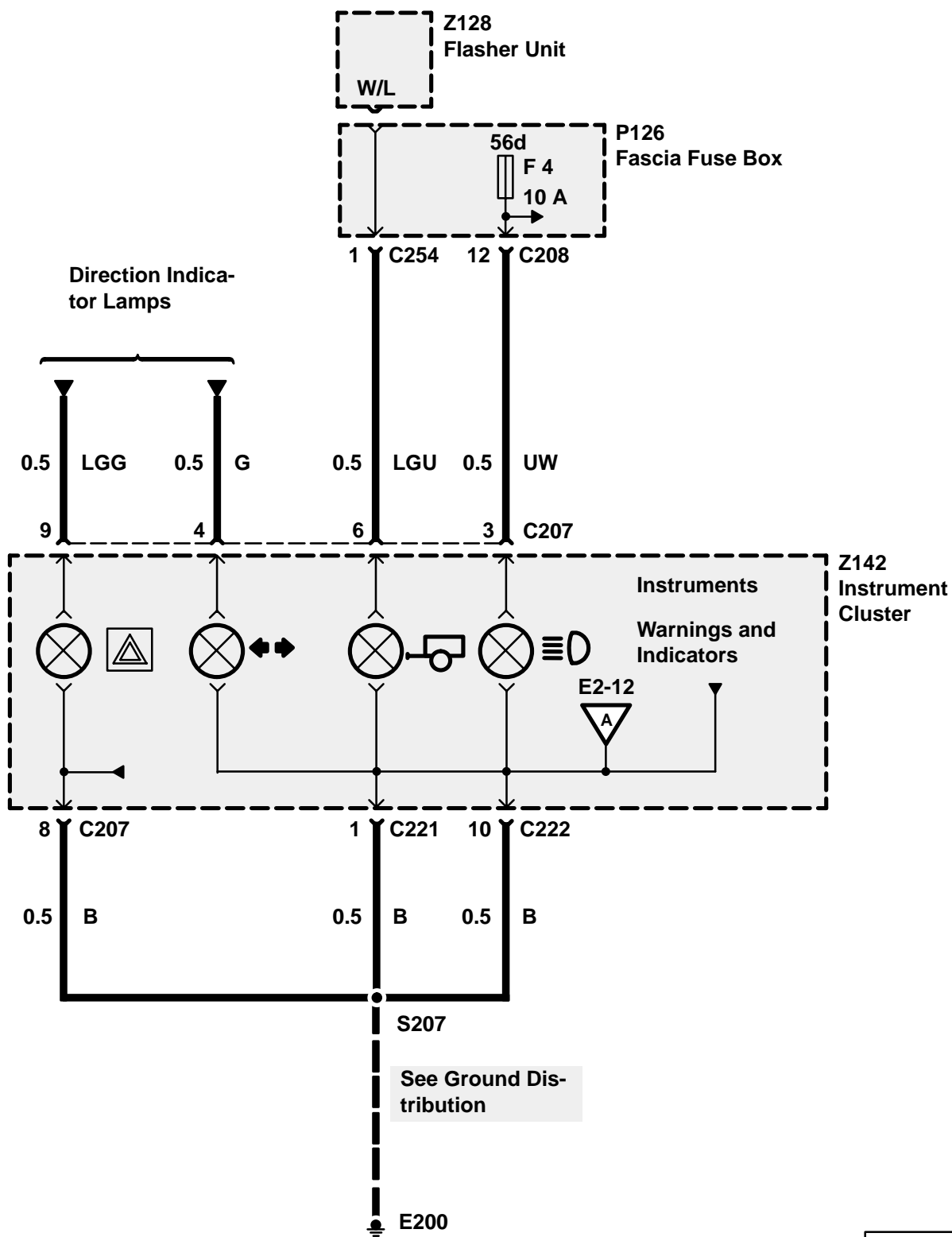

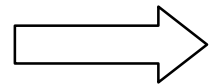
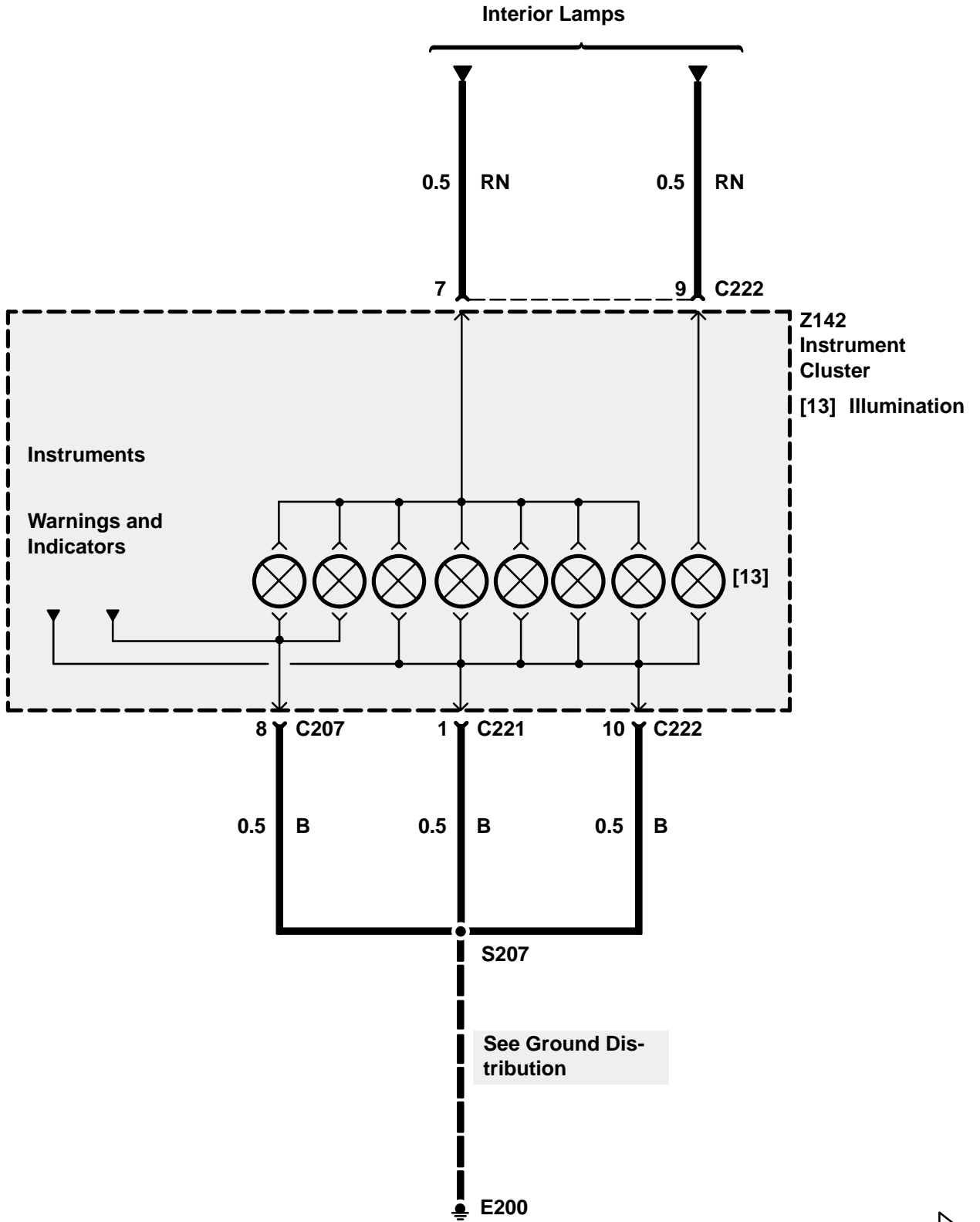

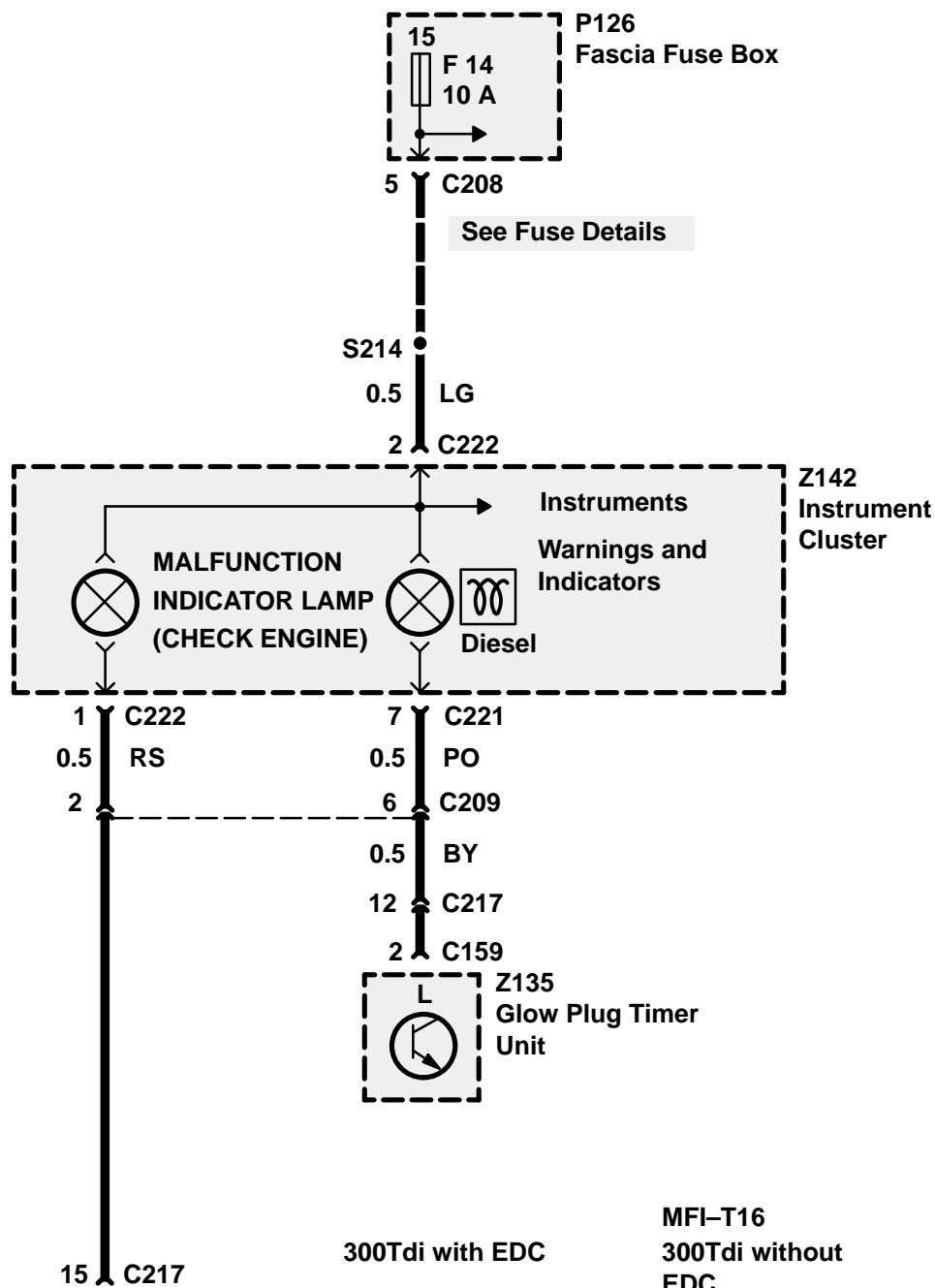
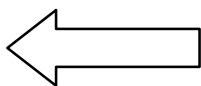

MFI-V8

300Tdi with EDC

MFI-T16  
300Tdi without EDC

Not used

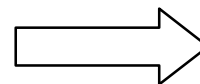
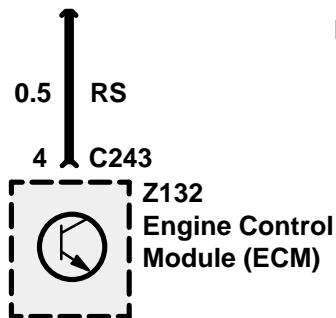
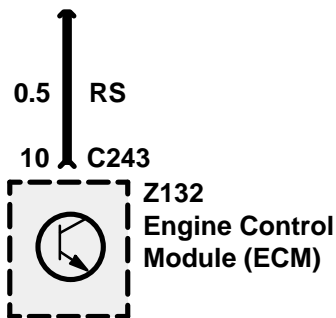

# E2 ETM

## DISCOVERY

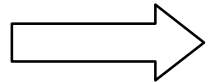
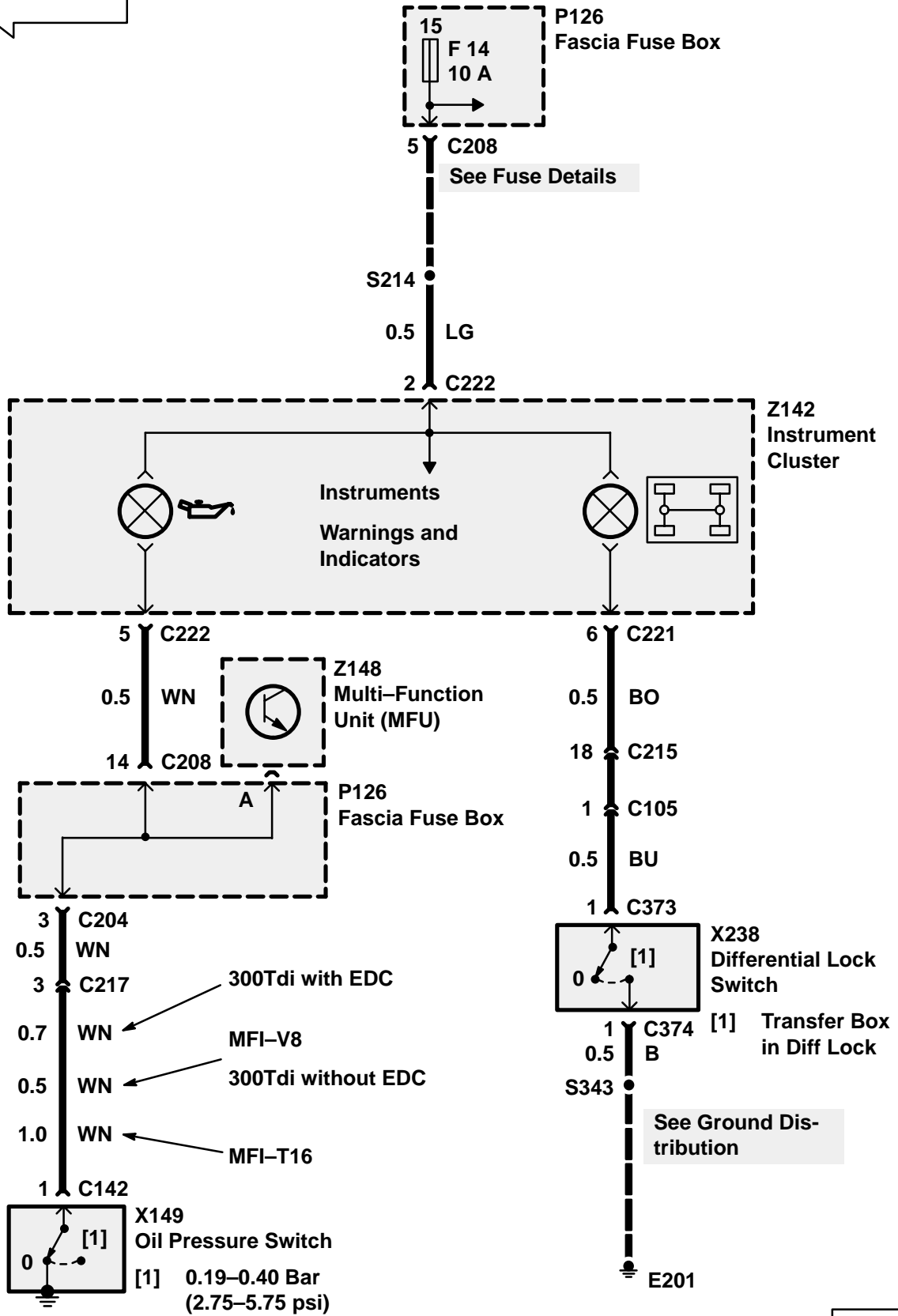
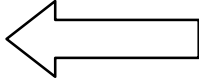

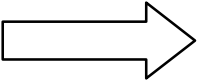
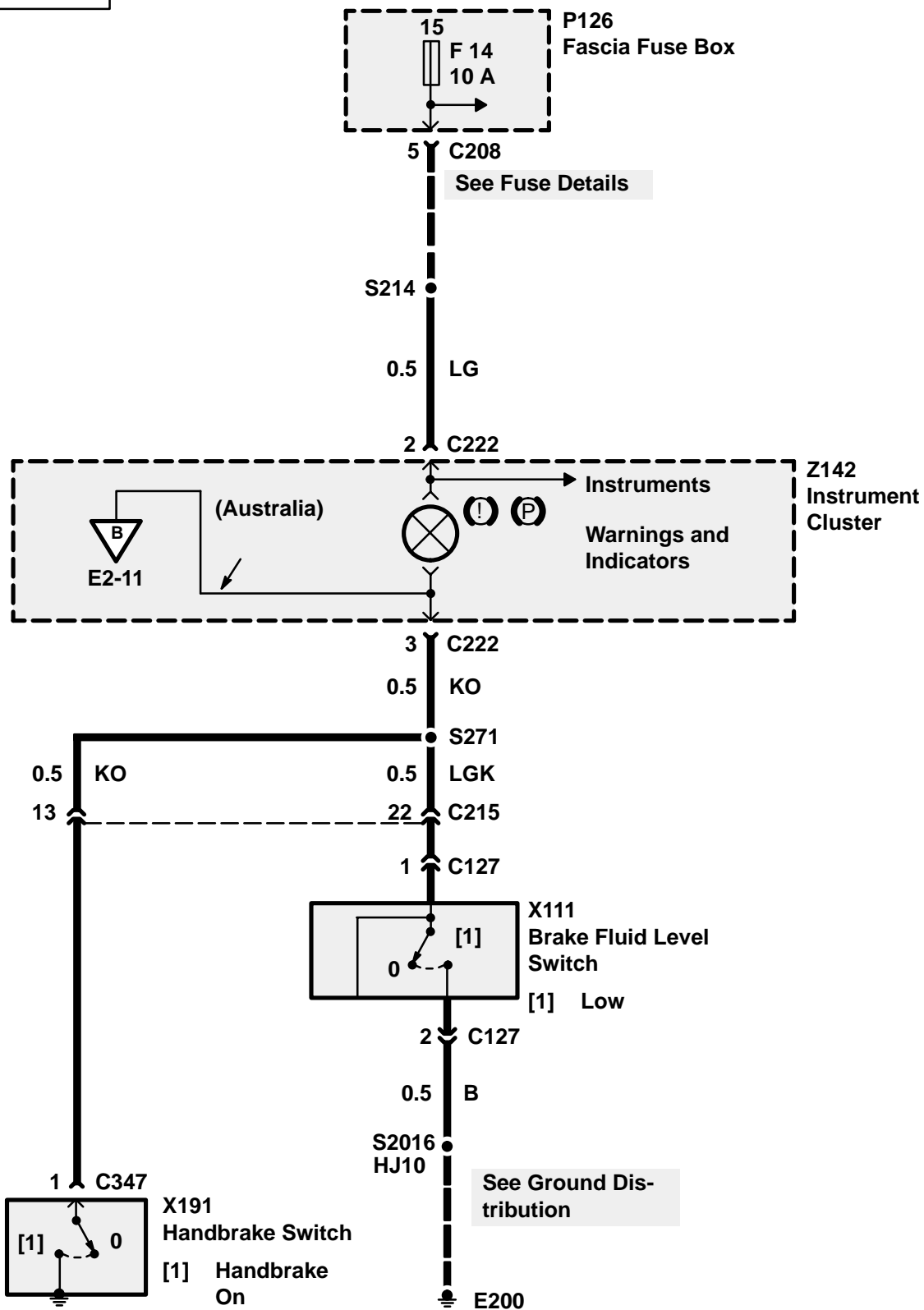
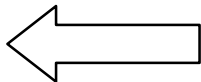

**DISCOVERY**

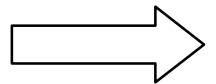
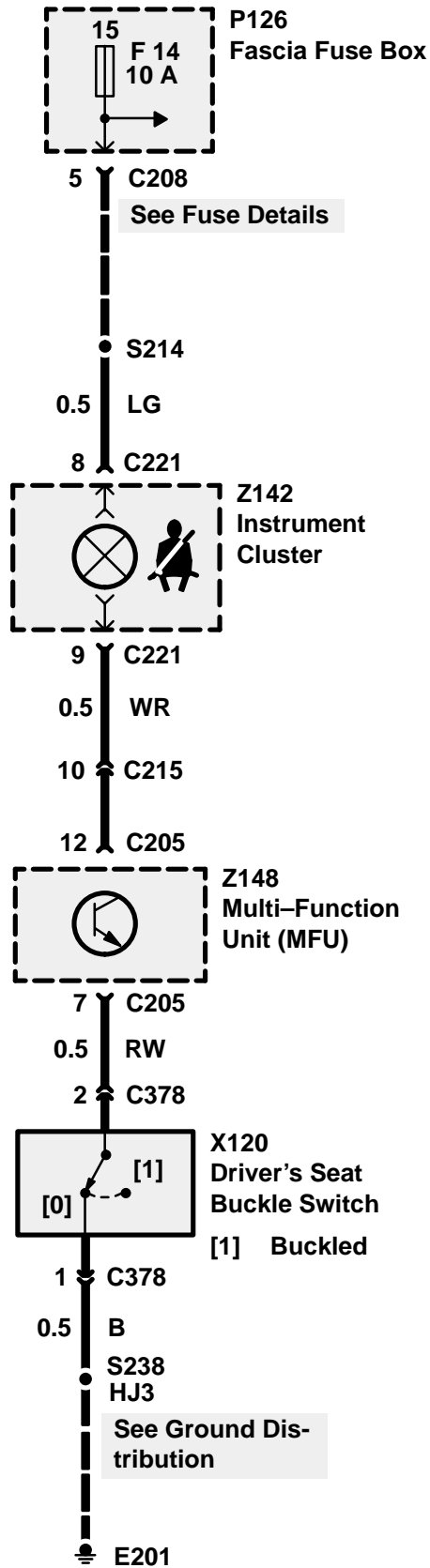
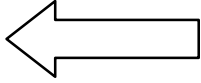

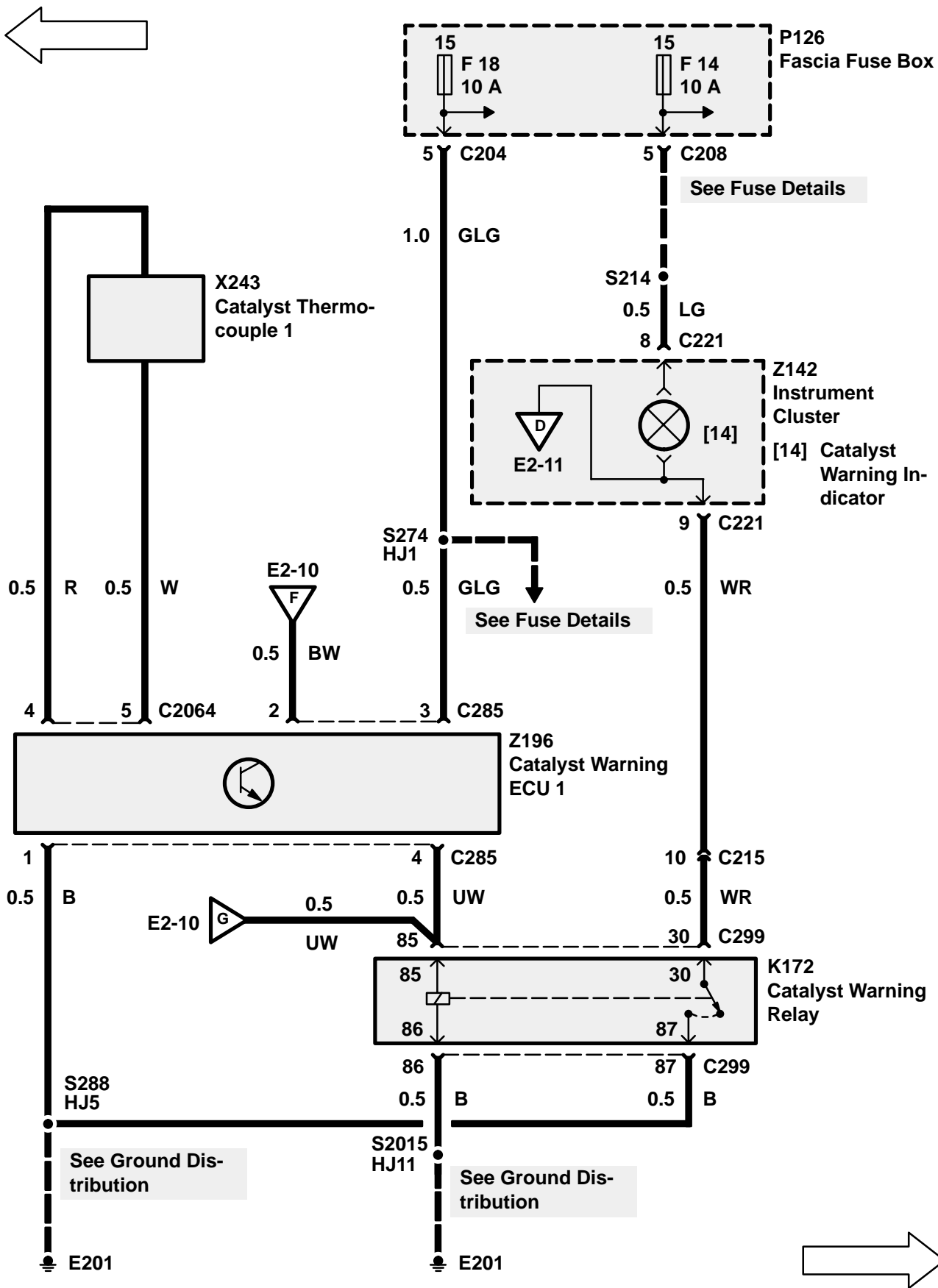

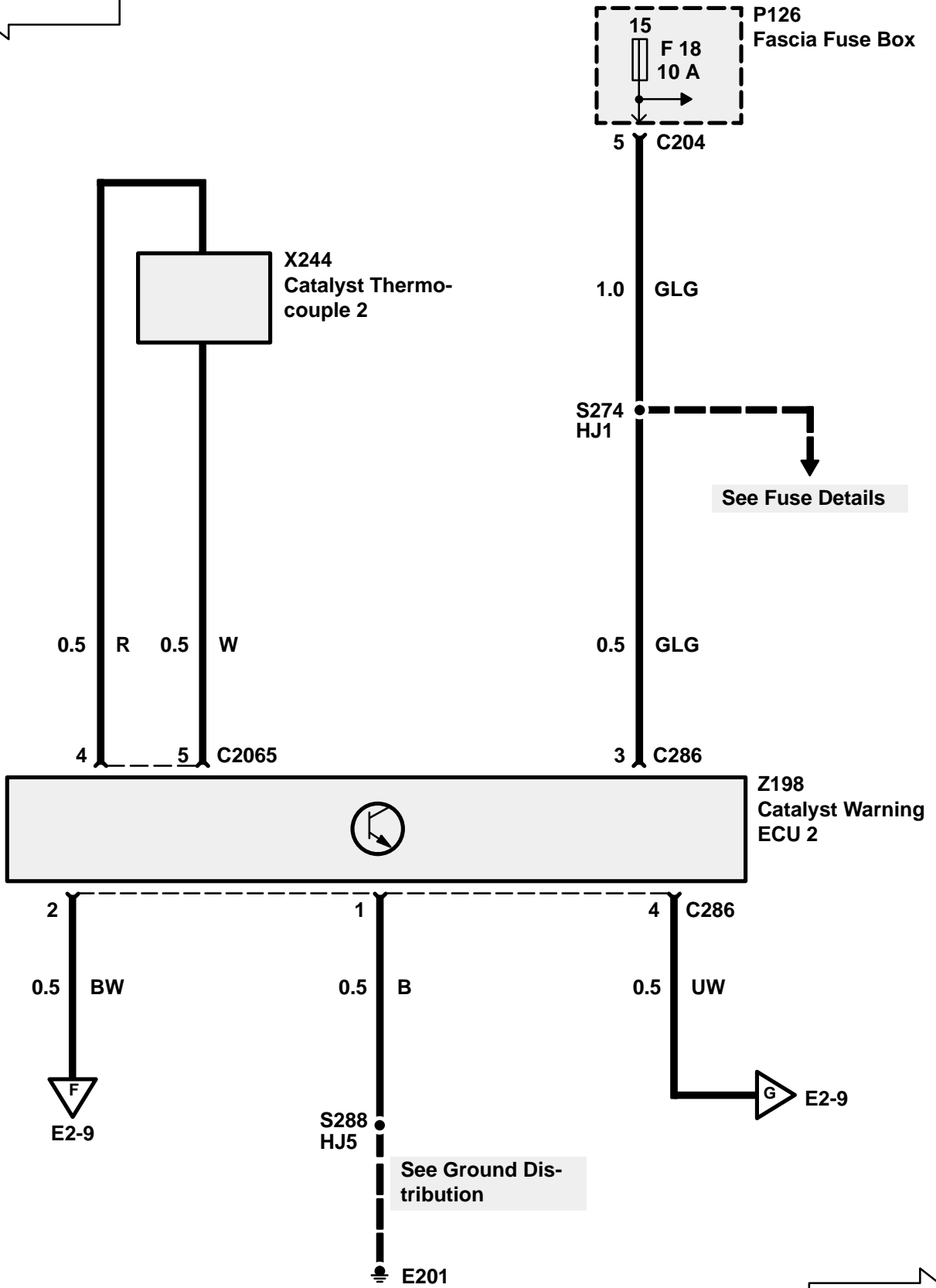

See Fuse Details

See Ground Distribution

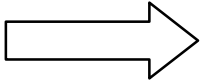



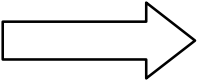
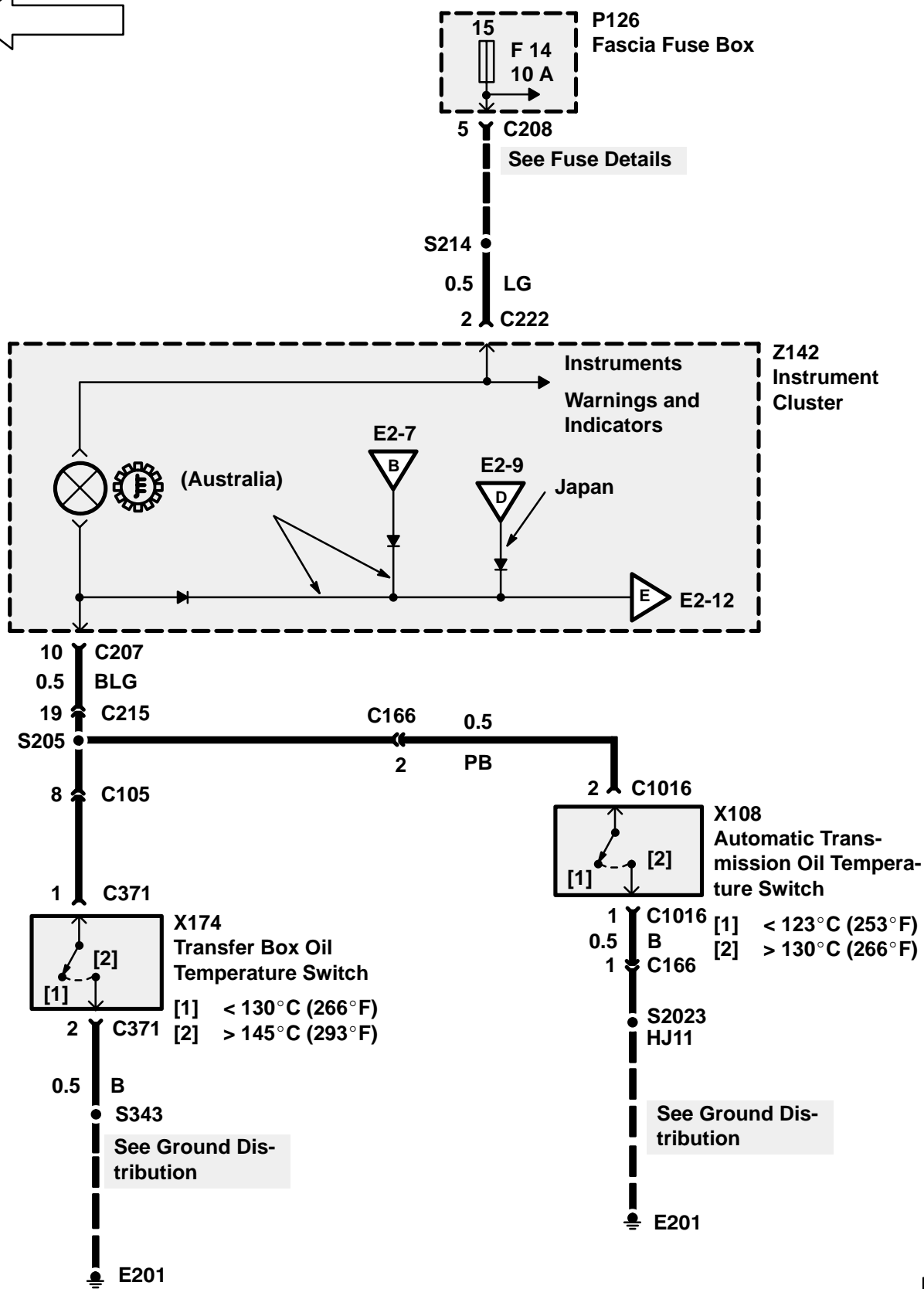
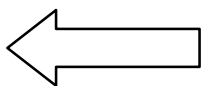

# E2 ETM

## DISCOVERY

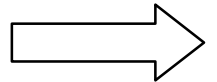
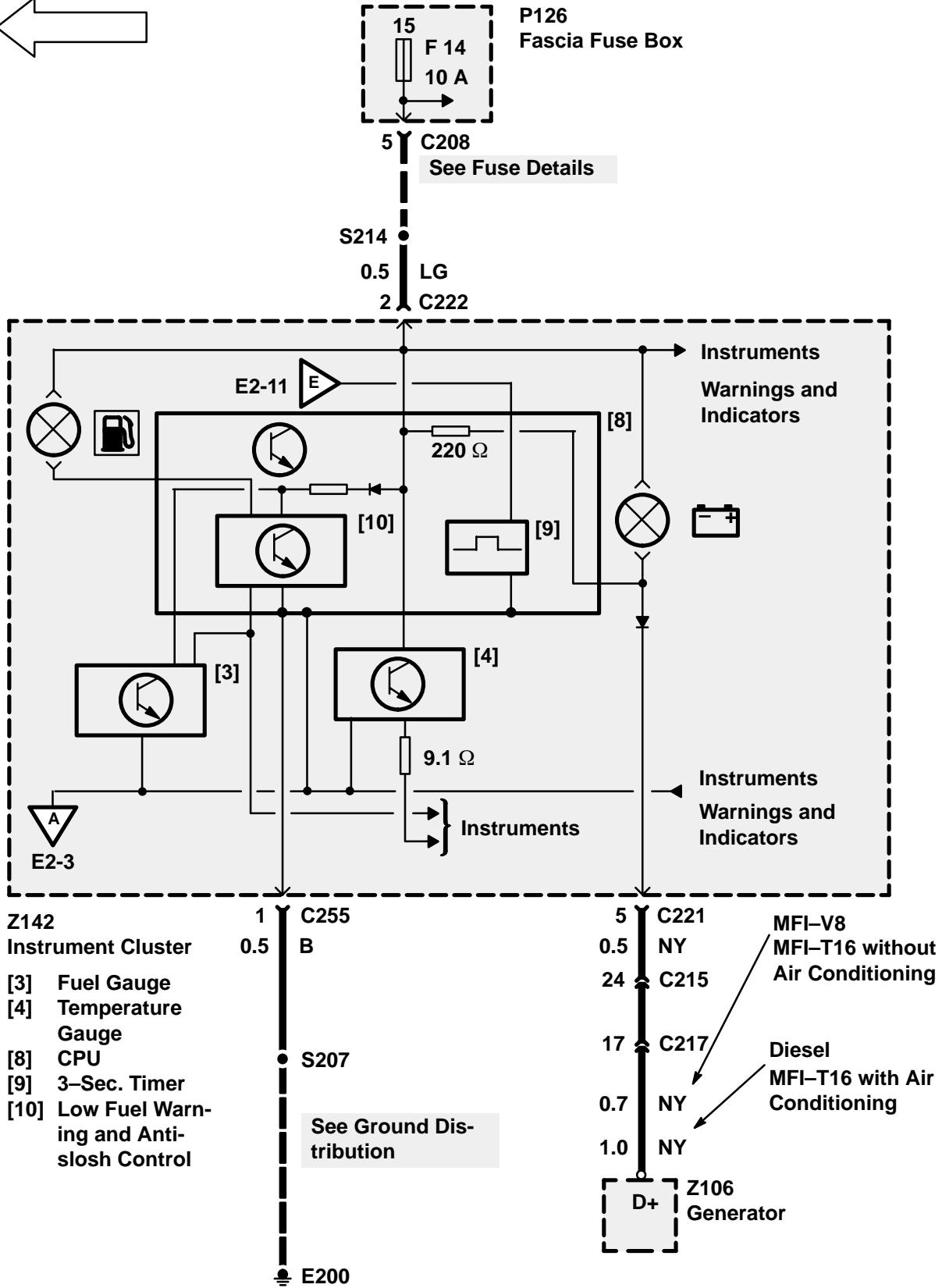
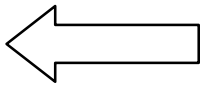

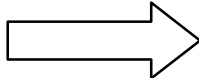
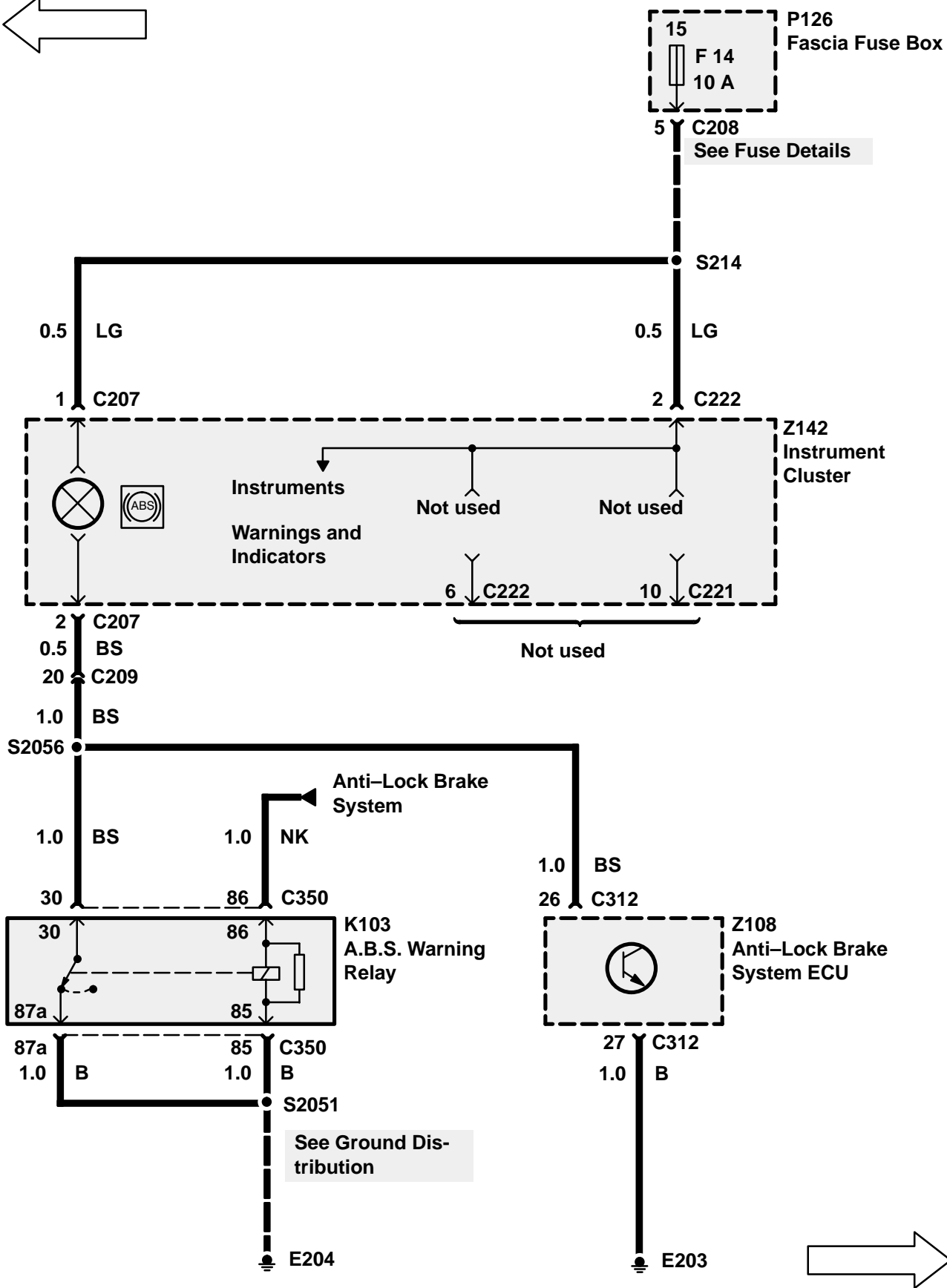
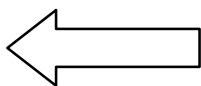

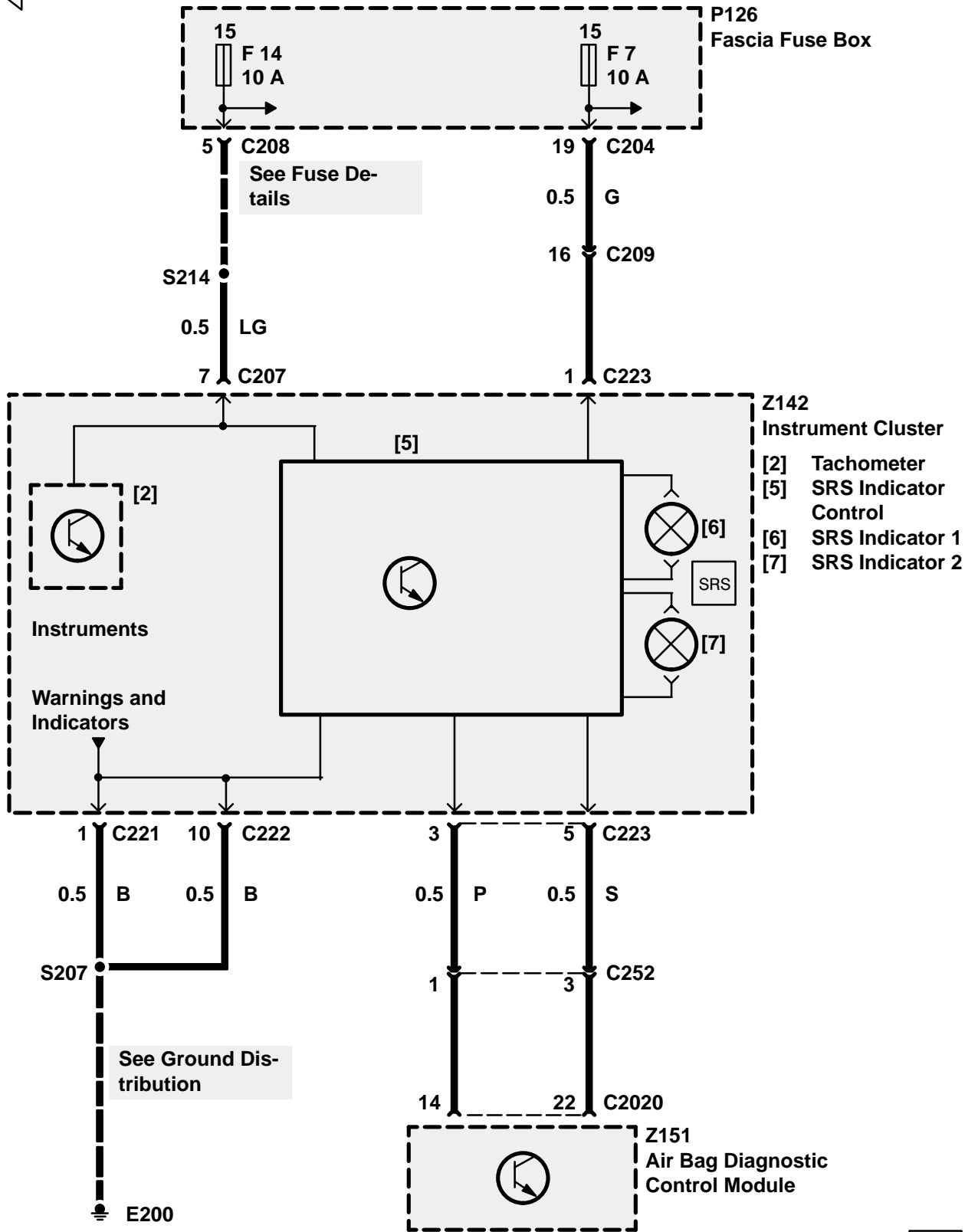
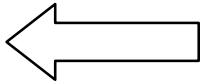

**TROUBLESHOOTING HINTS**

15. If more than one warning light is out, check power and ground wires common to all affected warning lights. If they are OK, replace Instrument Cluster (Z142).
16. If the Brake Warning Light does not operate at all, check Instrument Cluster (Z142) and K Wire.  
For Australian vehicles:
17. If the Brake Warning Light, the Catalyst Warning Indicator, and the Transmission Box Oil Temperature Warning Light don't illuminate, as a bulb test, with the ignition on, replace Instrument Cluster (Z142). If all three indicators don't turn off with the engine running, replace Instrument Cluster (Z142).

**SYSTEM DIAGNOSIS**

1. If the Charge Warning Light does not operate, go to Section B1.
2. If the Oil Pressure Warning Light remains illuminated with the oil pressure OK, do Test A.
3. If the Malfunction Indicator Lamp (Check Engine) does not operate, do Test B for MFI-V8 engines, Test C for 300TDI with EDC engines.
4. If the Glow Plug Indicator does not operate, do Test D.
5. If the Brake Warning Light does not operate with the brake fluid level low, do Test E.
6. If the Brake Warning Light does not operate with the handbrake applied, do Test F.
7. If the Differential Lock Indicator remains on after the differential lock has been disengaged, transmission "wind up" may be present. Drive the vehicle in reverse for a short distance, then drive forward for a short distance. If the light remains on after driving in reverse, do Test G.
8. If the Fasten Seat Belt Indicator does not operate with the ignition on, do Test H.
9. If the Transmission/Transfer Box Oil Temperature Warning Light is illuminated with both the Transfer Box Oil Temperature and the Automatic Oil Temperature OK, do Test I.
10. If a warning light exhibits any symptom not mentioned above, check the associated bulb, wires, switches, and components.

**Test A**

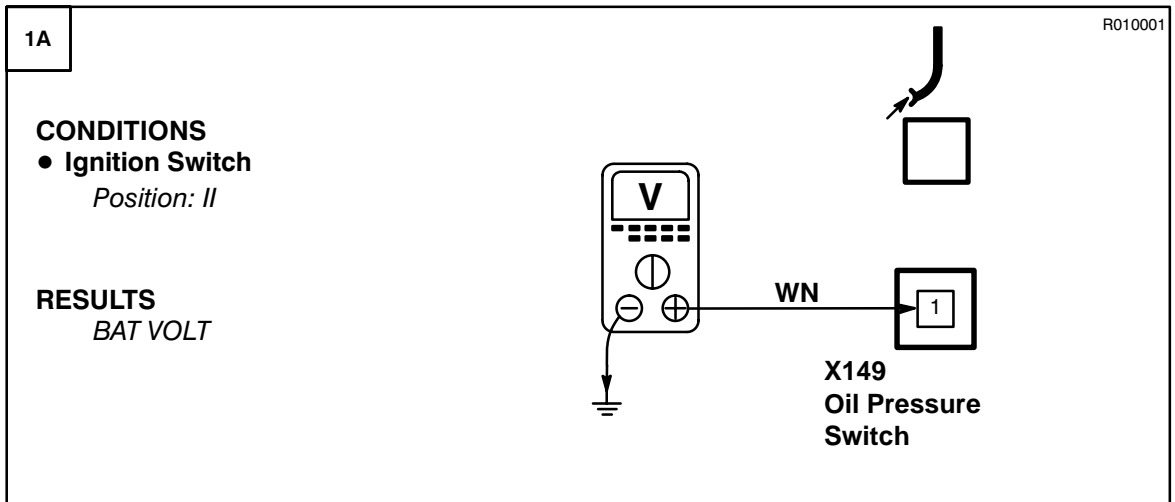

**OK** PROBLEM CAUSE  
- WN Wire

**OK** PROBLEM CAUSE  
- Oil Pressure  
Switch

**Test B**

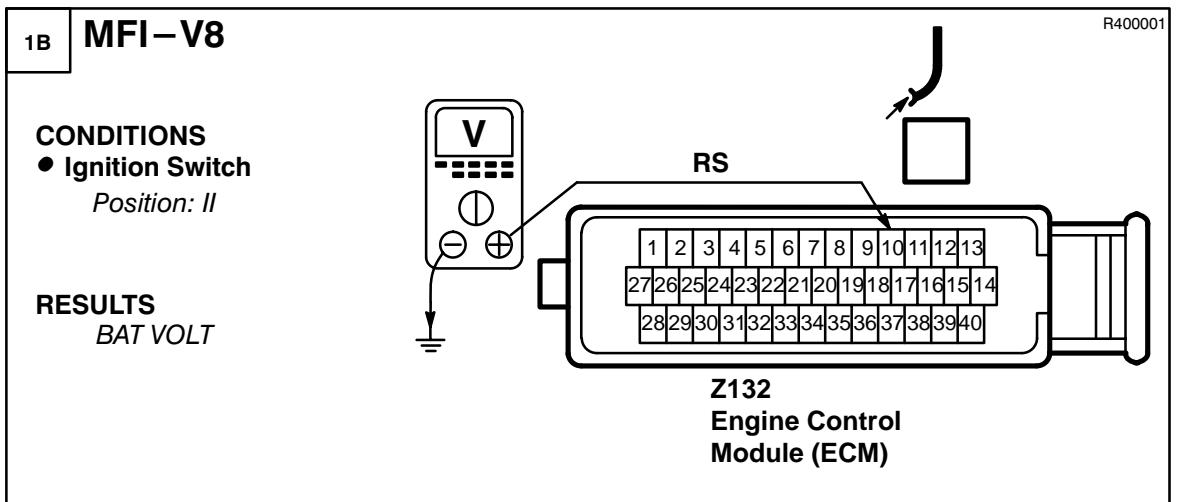

**OK**

↓

**2B**

**OK** PROBLEM CAUSE  
- Engine Control  
Module (ECM)

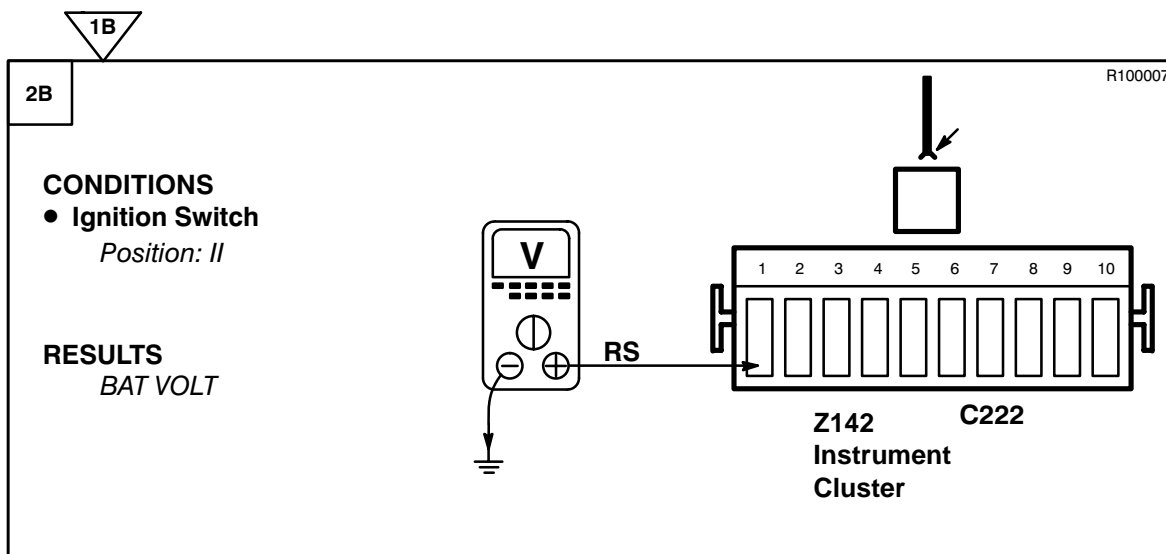

**PROBLEM CAUSE**  
- Instrument Cluster



**PROBLEM CAUSE**  
- LG Wire  
- RS Wire

**Test C**

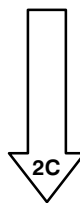
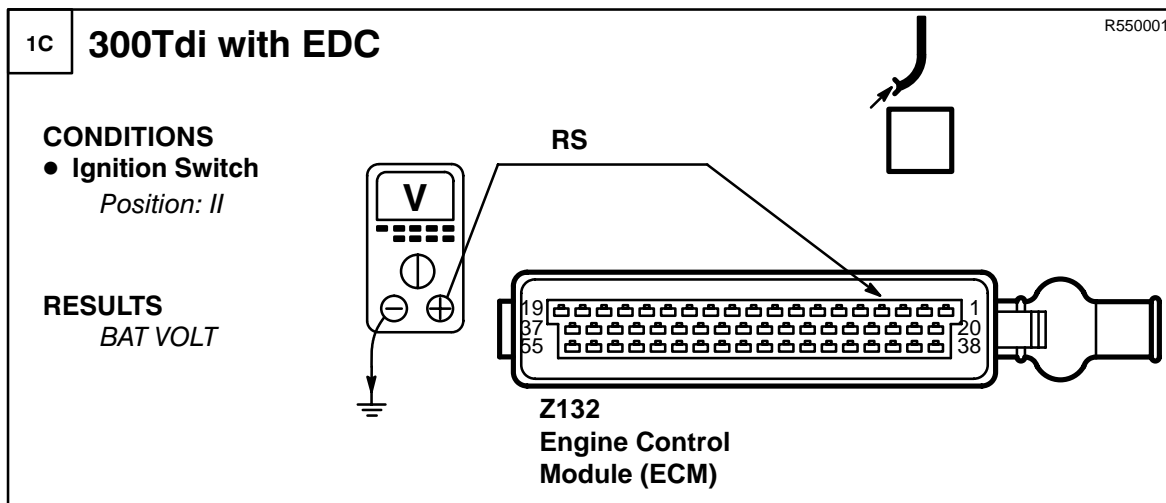

**PROBLEM CAUSE**  
- Engine Control Module (ECM)

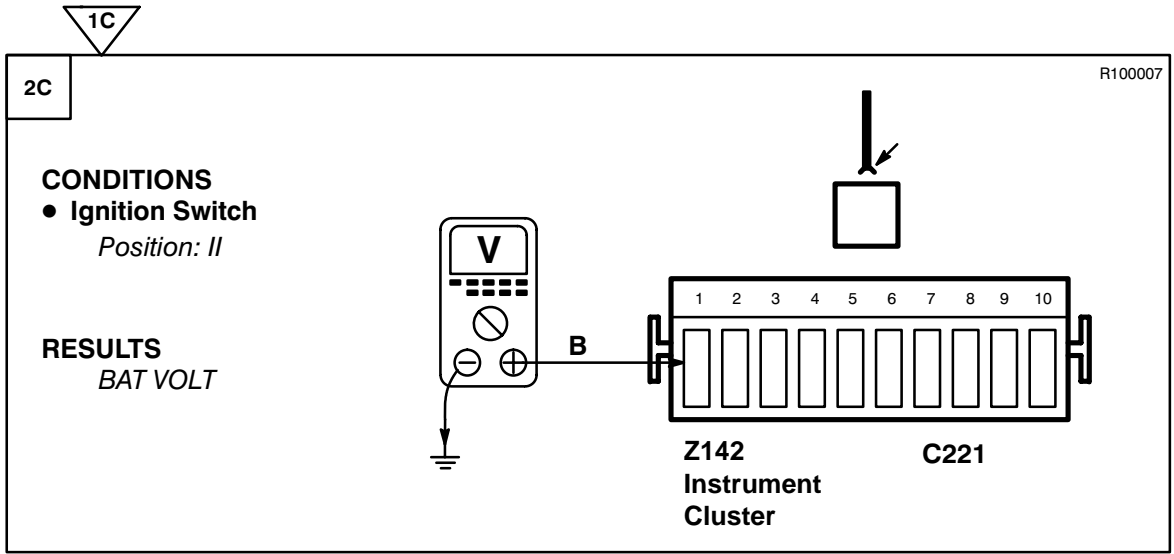

**PROBLEM CAUSE**  
 - Instrument Cluster



**PROBLEM CAUSE**  
 - LG Wire  
 - RS Wire

**Test D**

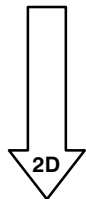
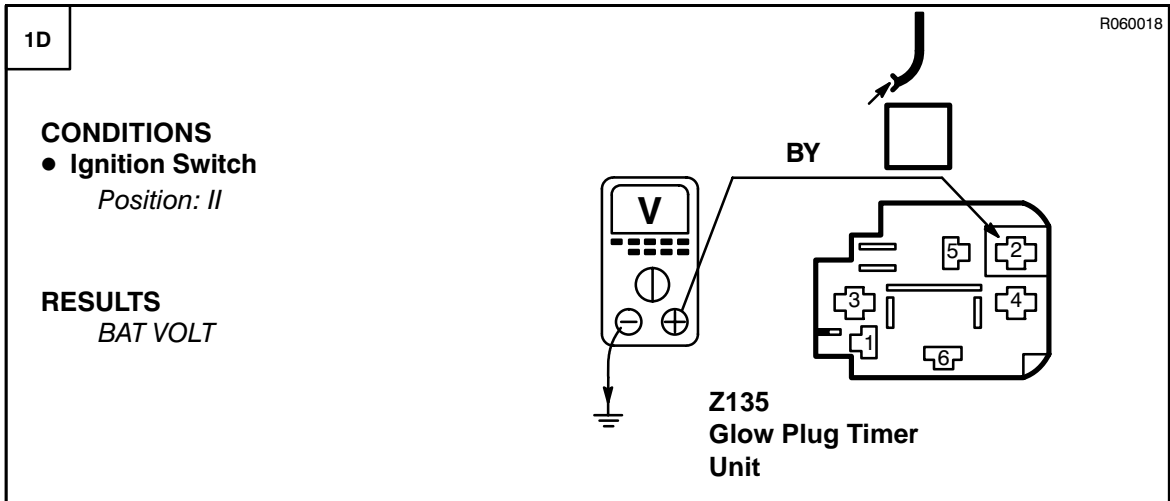

**PROBLEM CAUSE**  
 - Glow Plug Timer Unit



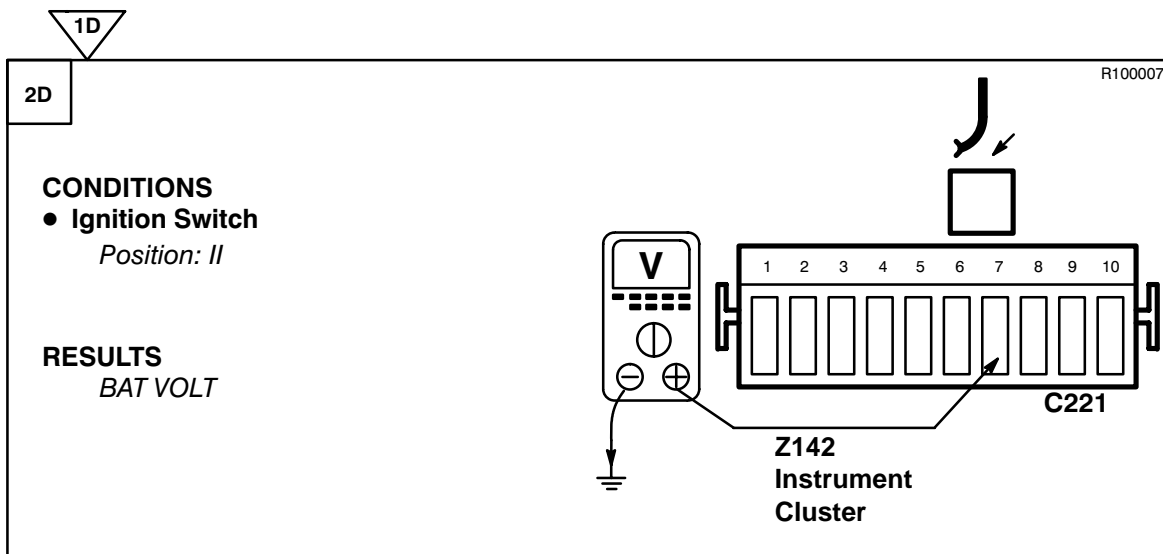

**PROBLEM CAUSE**  
 - Instrument  
 Cluster



**PROBLEM CAUSE**  
 - PO Wire  
 - BY Wire

**Test E**

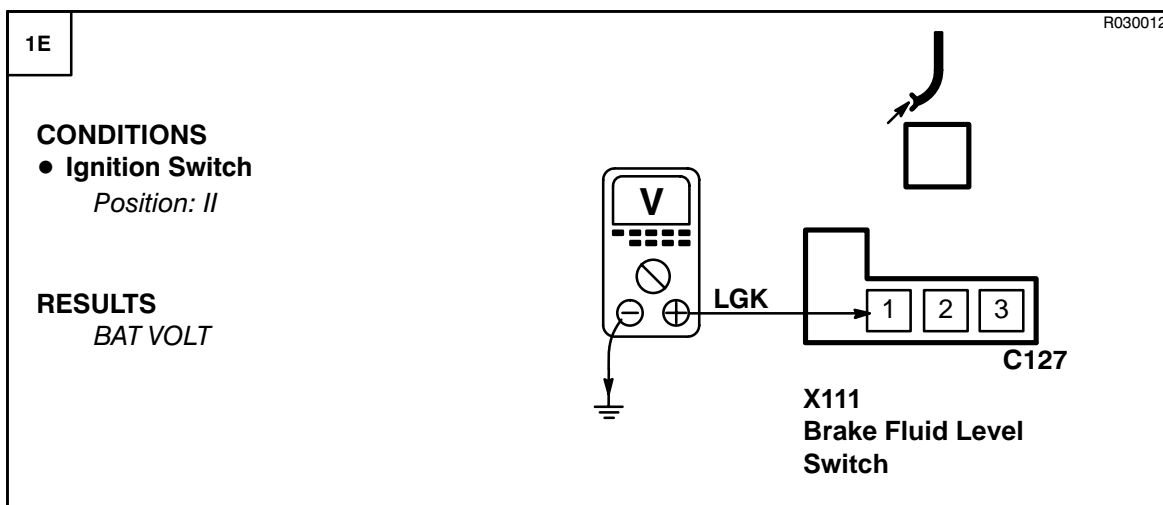

**PROBLEM CAUSE**  
 - LGK Wire  
 - Instrument  
 Cluster



**PROBLEM CAUSE**  
 - B Wire  
 - Brake Fluid Level  
 Switch

### Test F

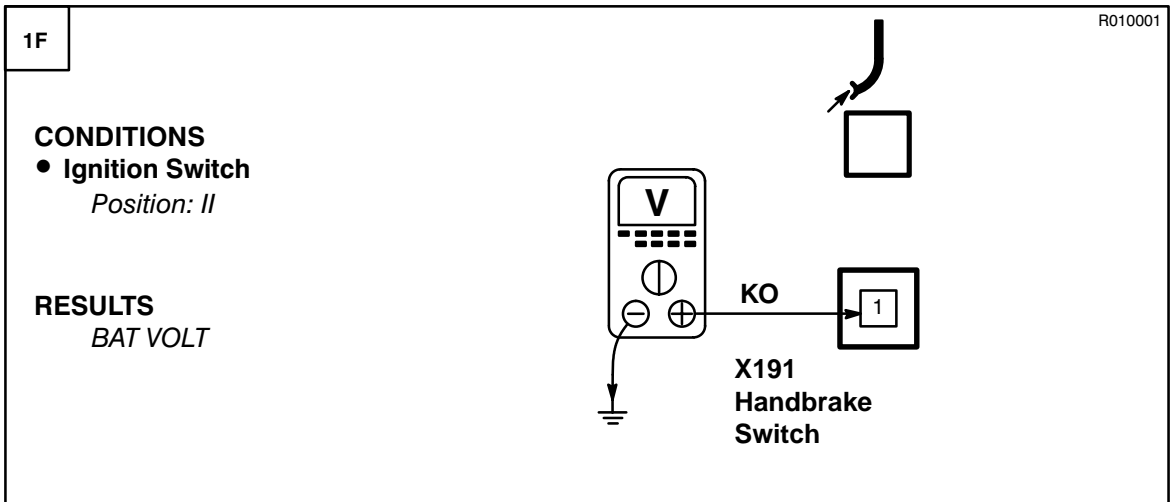

**OK** PROBLEM CAUSE  
- KO Wire

**OK** PROBLEM CAUSE  
- Handbrake Switch

### Test G

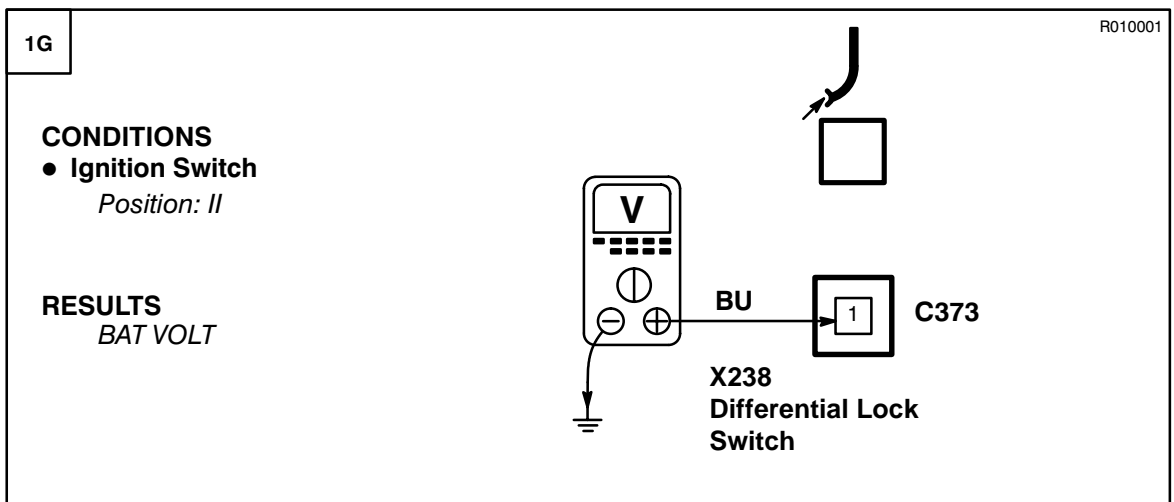

**OK** PROBLEM CAUSE  
- LG Wire  
- BO Wire  
- BU Wire

**OK** PROBLEM CAUSE  
- Differential Lock  
Switch

**Test H**

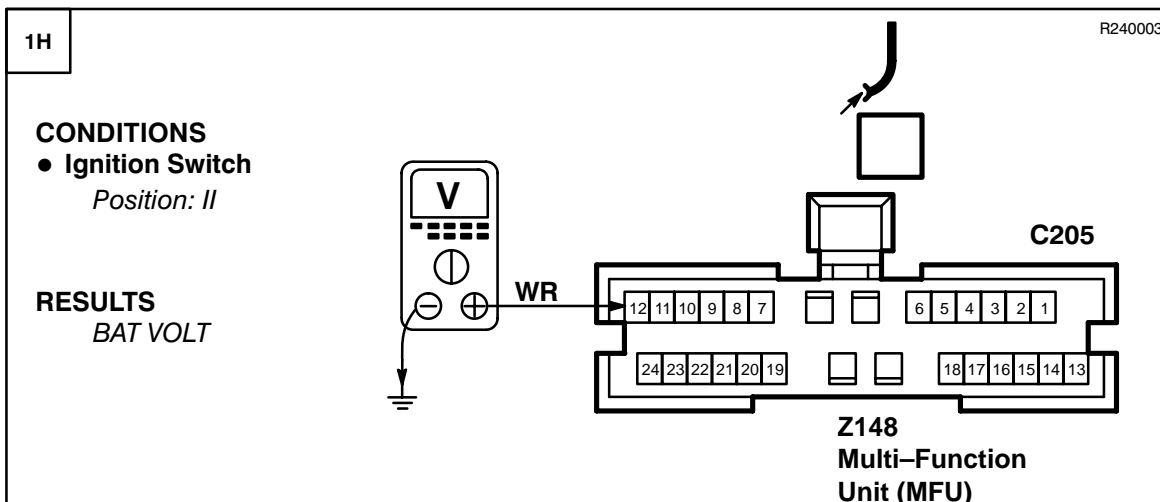

**PROBLEM CAUSE**

- WR Wire
- LG Wire
- Instrument Cluster

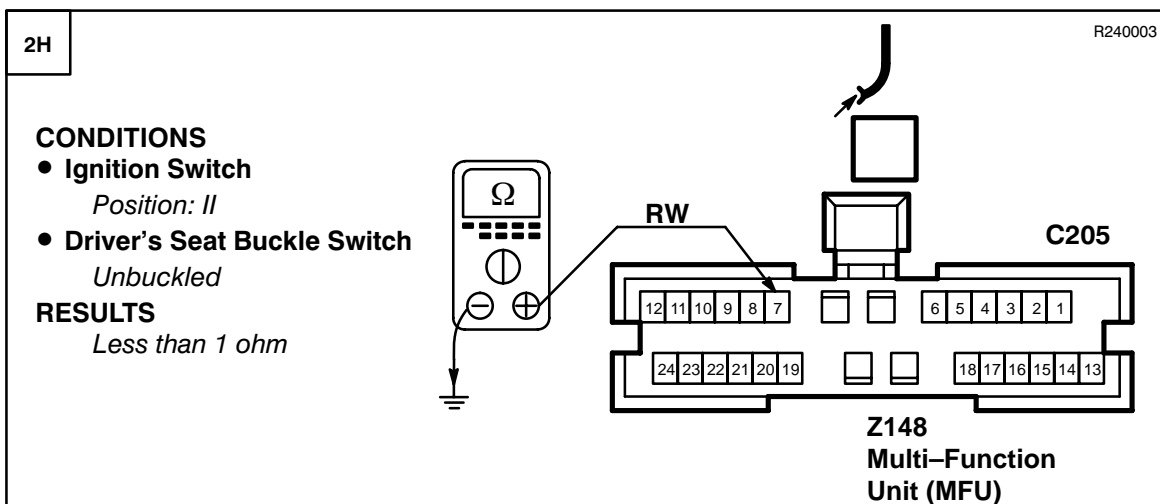
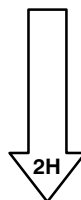

**PROBLEM CAUSE**

- RW Wire
- B Wire
- Driver's Seat Buckle Switch



**PROBLEM CAUSE**

- Multi-Function Unit (MFU)

**Test I**

R020003

11

**CONDITIONS**

- Ignition Switch  
*Position: II*

**RESULTS**  
*BAT VOLT*

**X108**  
Automatic Transmission Oil Temperature Switch

**OK** PROBLEM CAUSE

- BLG Wire
- Transfer Box Oil Temperature Switch

**OK** PROBLEM CAUSE

- Automatic Transmission Oil Temperature Switch

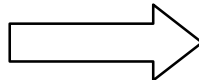
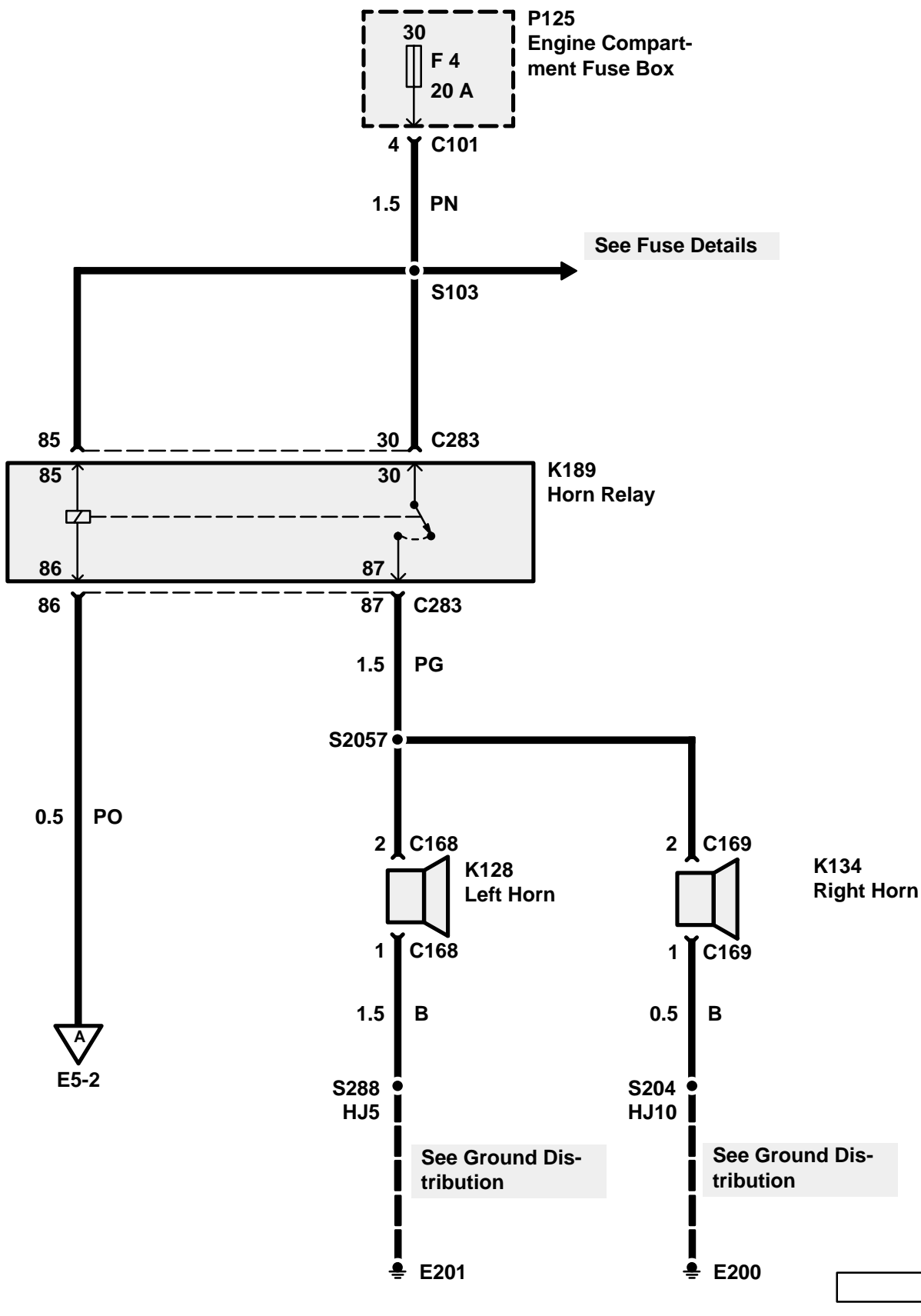

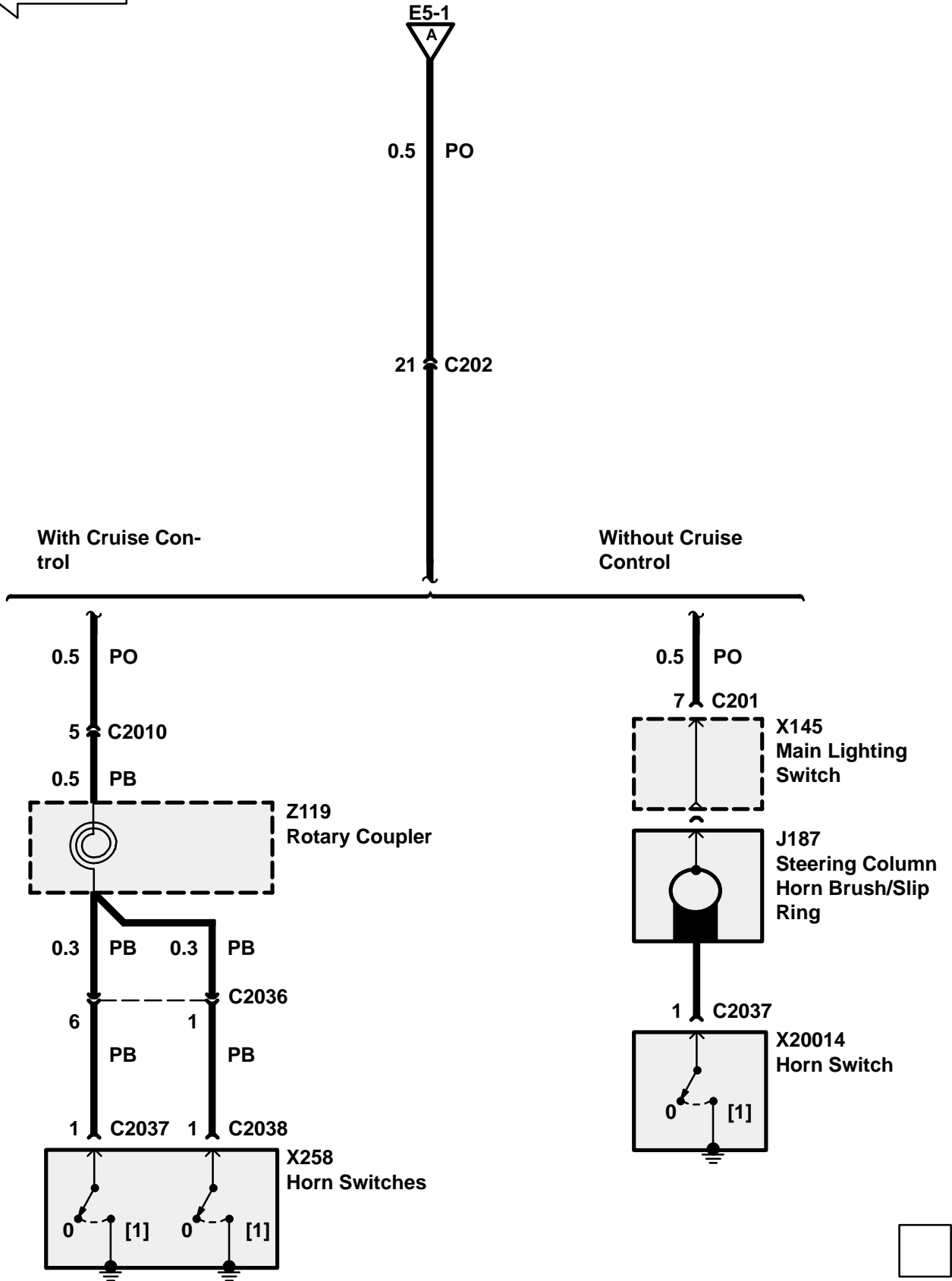
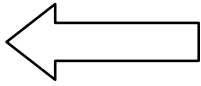

## CIRCUIT OPERATION

The audio system consists of a new head unit and for mid/high range it is equipped with a subwoofer and subwoofer amplifier. For mid and high range the system also is equipped with a radio waveband switch and a tune switch, a volume up and a volume down switch which are located on the fascia next to the instrument cluster.

The control head is equipped with an anti-theft feature which makes the unit inoperative once battery power is removed. A security code must be entered to restore power to the unit. On every level the system is equipped with two rear and two front speakers.

Battery voltage is provided to the control head at all times through the P wire. In addition to monitoring the anti-theft feature, this input keeps the preset station memory alive. Whenever battery power to the unit is lost, the anti-theft code must be entered and the preset stations must be reprogrammed.

When the Radio (Z111) and the ignition are turned on, the voltage signal through the LGO wire and the control head 'wakes up' the unit. The Radio (Z111) plays, the VF display comes on and the control unit buttons illuminate. The VF display is dimmed when the headlights or park lights are turned on. When the lights are on, voltage from fuse F8 of the Fascia Fusebox (P126) is applied to the Radio (Z111) terminal 6, connector 230 signalling the Radio (Z111) to dim the display.





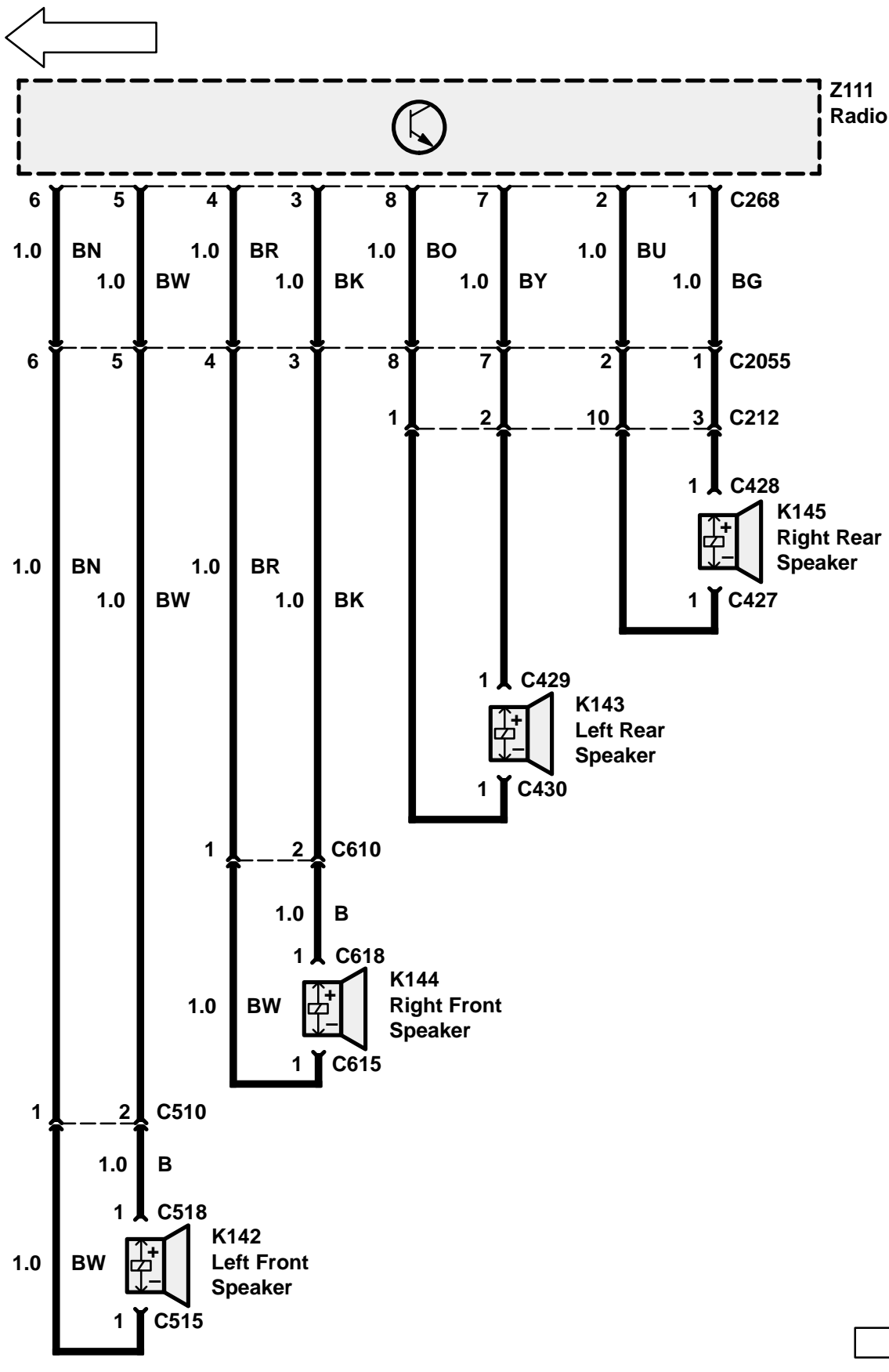

# E6 ETM

## DISCOVERY

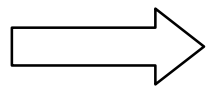
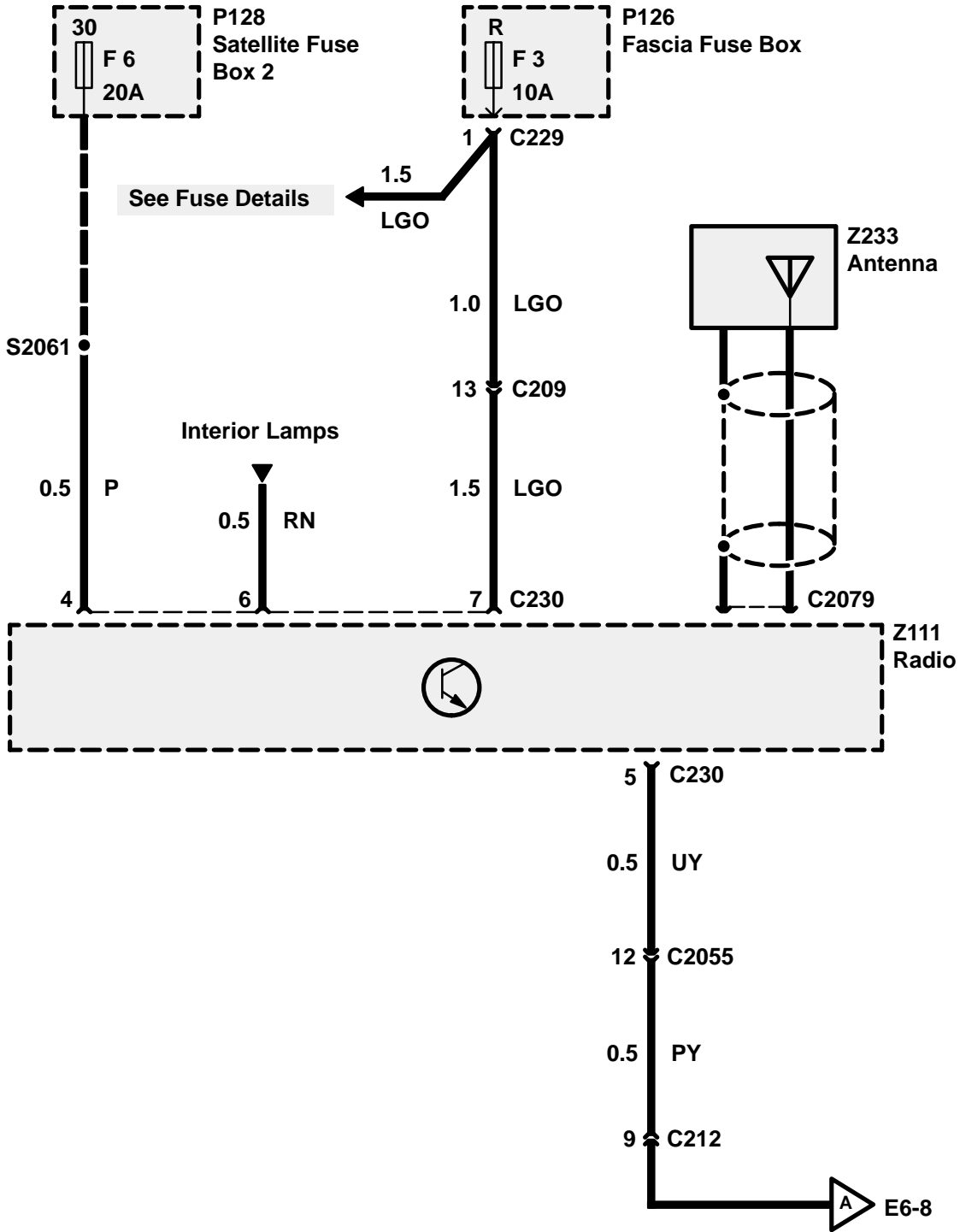
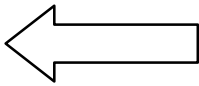

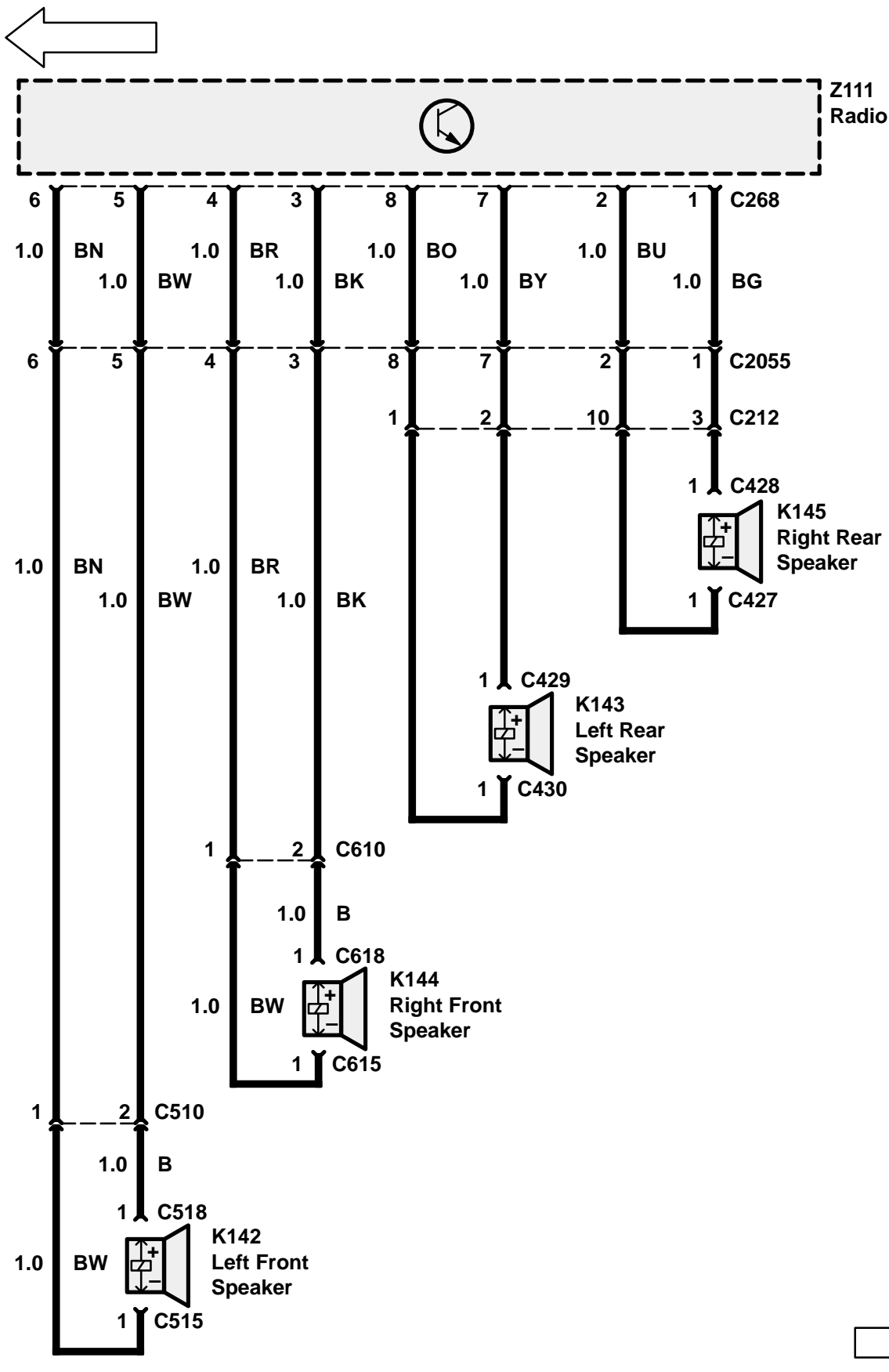

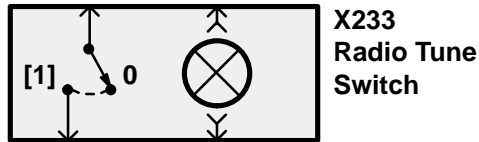
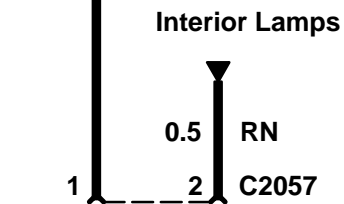
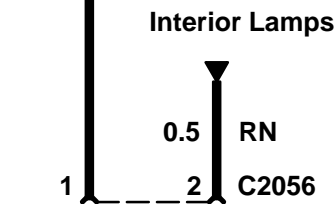
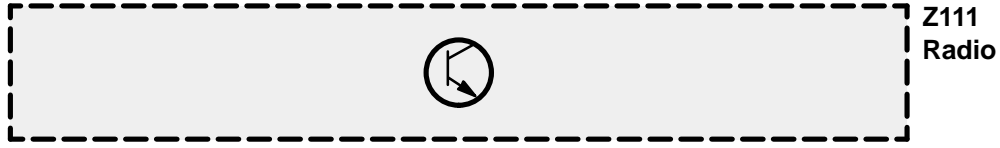
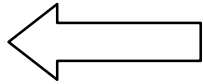

S217

S255 HJ8 See Ground Distribution

See Ground Distribution

E200

E200

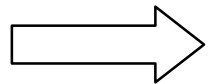

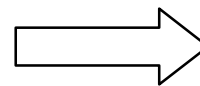
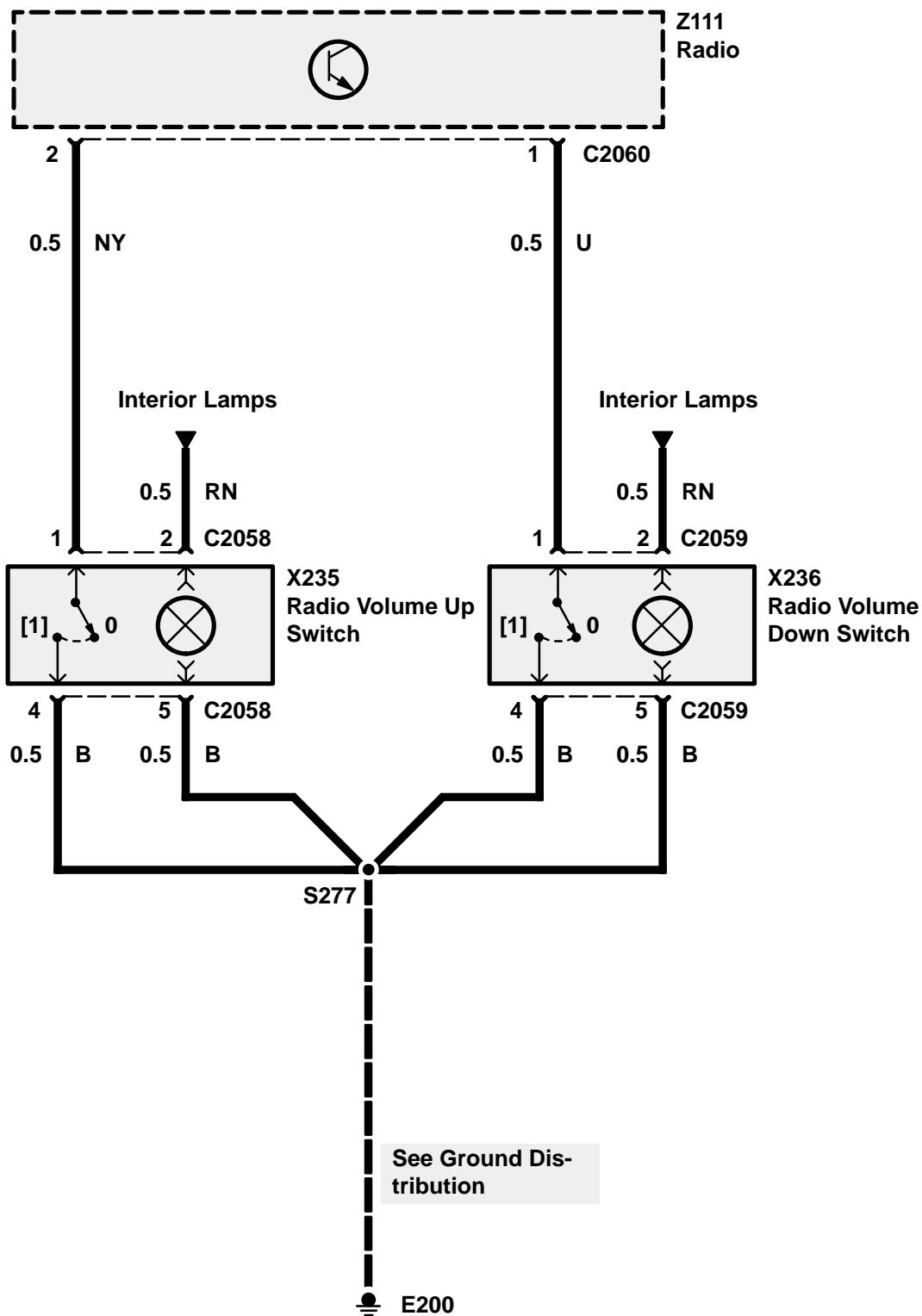
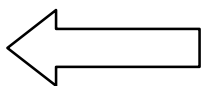

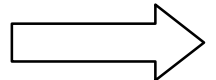
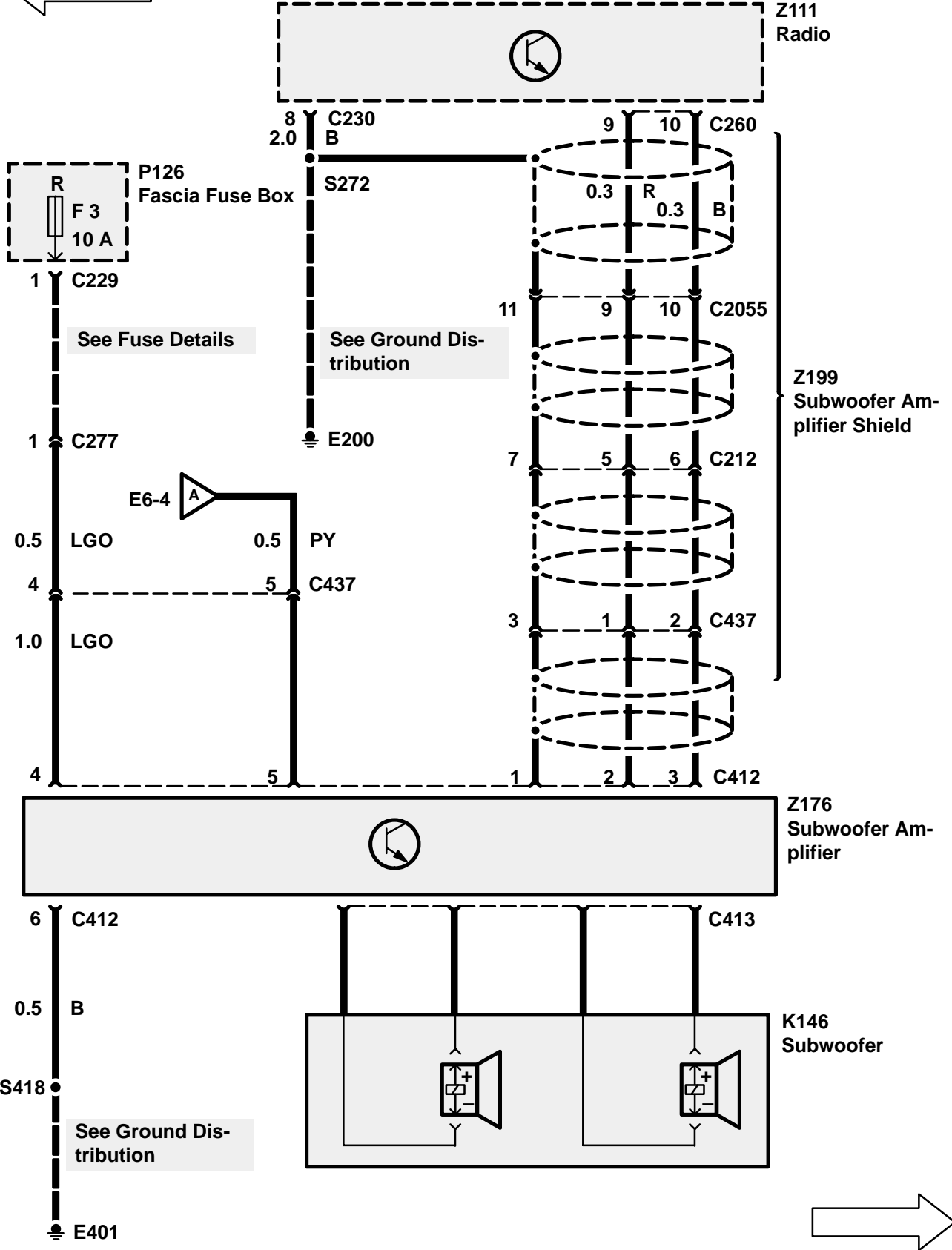

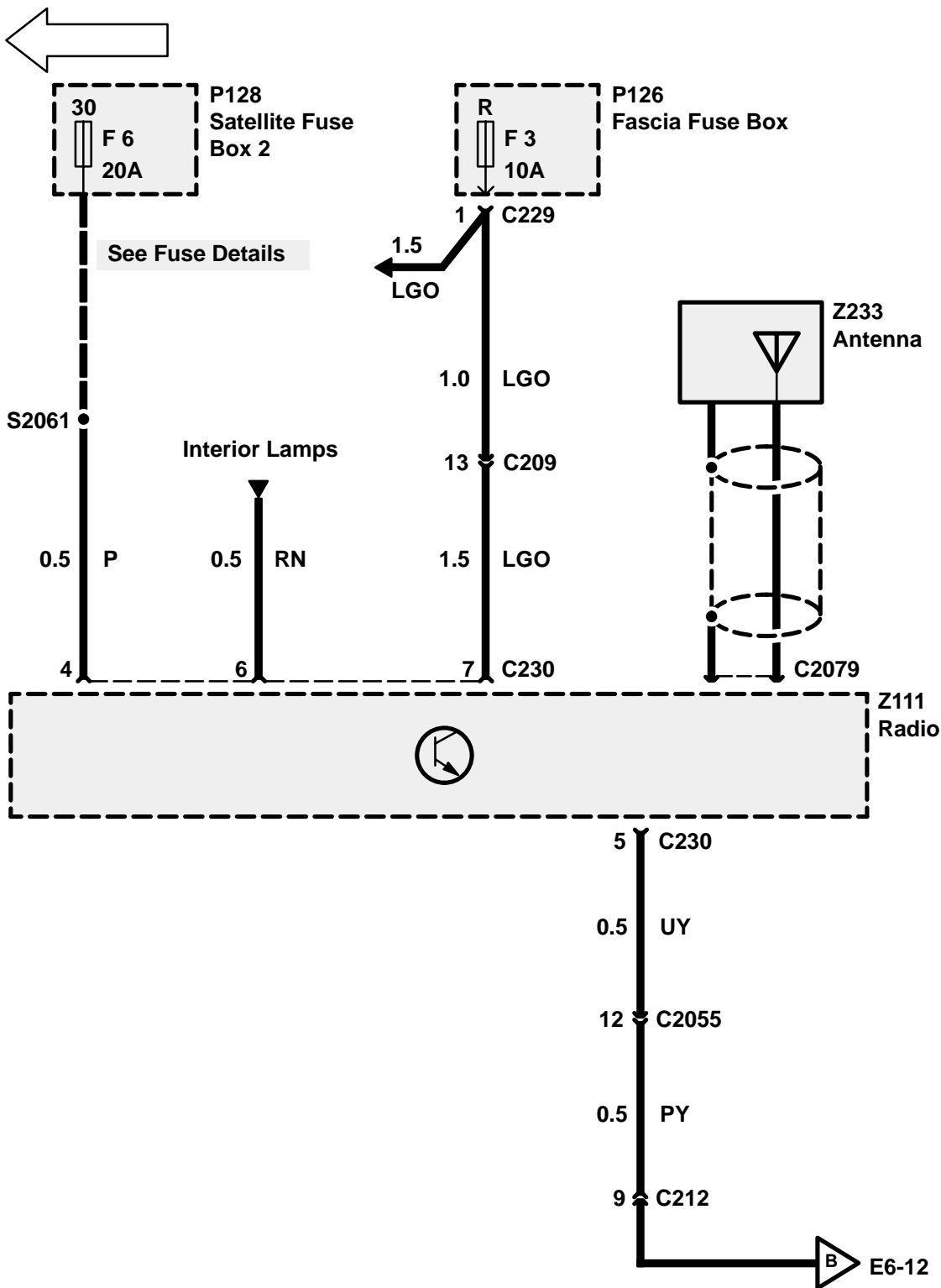





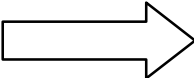
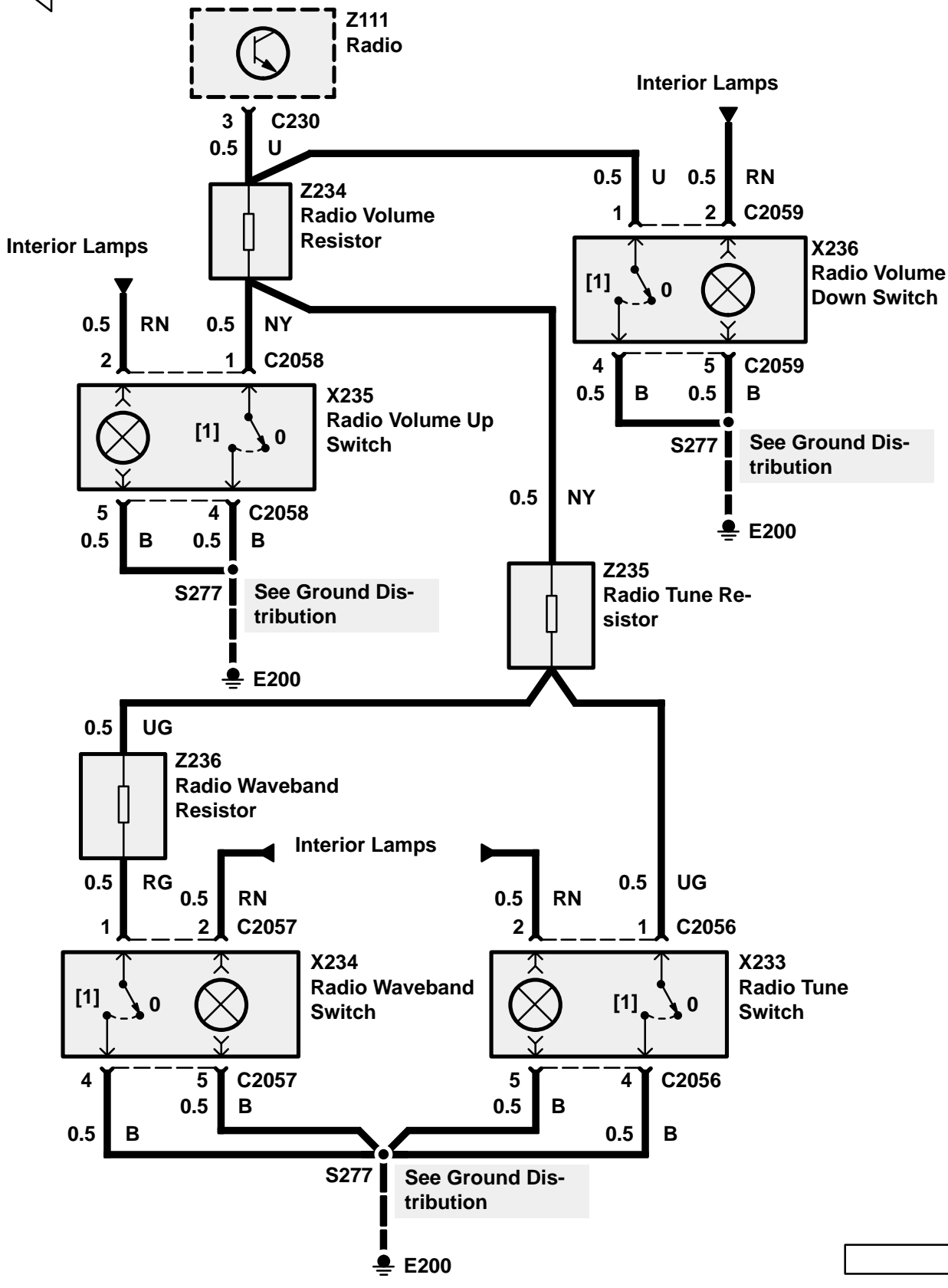
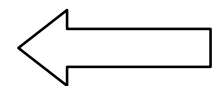



**TROUBLESHOOTING HINTS**

1. Check fuses F6 in the Satellite Fusebox 2 (P128) and F3 in the Fascia Fusebox (P126).
2. Check that Radio (Z111) connectors and coaxial cable are tight and properly connected.
3. For proper Radio (Z111) noise diagnosis, take the vehicle outside where signals are strong. Close the hood and keep away from metal buildings or other sources of radio interference.
4. If Radio (Z111) noise is excessive when an accessory is on, install a Radio noise suppression capacitor to the power lead of that accessory.
5. If Radio (Z111) noise is excessive at all times, check antenna wiring. If OK, check spark plugs, spark plug wiring and wiring close to the ignition system which could transmit noise to the Radio (Z111) wiring.
6. If the Radio (Z111) is inoperative and 'code' is being shown on the display, follow the instructions below.
7. If the radio scans past all frequencies when in seek mode and hiss is present over most stations, substitute antenna with a known good antenna. If the reception is still inadequate, replace radio.

**Security Code Instructions**

1. Obtain 5-digit security code from vehicle owner or manufacturer.
2. Enter the code number using the Radio (Z111) push-button selectors.

NOTE: If the correct code is not entered in 3 successive attempts, the Radio (Z111) will not accept another entry until the Radio has been left on for 1 hour with the ignition on.

NOTE: When entering the code, be sure to complete the sequence numbering of that 5-digit code even if you made a mistake. For example, if the correct code number sequence is 43215 and you mistakenly enter 42 instead of 43, continue the code number sequence of 215 to complete that entry. A 'beep' will sound, 'code' will still be displayed and the Radio will not operate. Re-enter the correct code 43215 and the Radio will operate.

NOTE: If an audible 'beep' is heard while entering the code, STOP immediately. Begin entering the code again, starting with the first number of the 5-digit code.

NOTE: If a push-button is touched accidentally when the ignition is off, a warning tone will sound. Turn the ignition on and the tone will stop.

**SYSTEM DIAGNOSIS**

1. If the Radio (Z111) does not operate at all on vehicles equipped with the Low Line Radio, do Test A.
2. If the Radio (Z111) does not operate at all on vehicles equipped with the Mid Line Radio, do Test B.
3. If the Radio (Z111) does not operate at all on vehicles equipped with the High Line Radio, do Test C.
4. If VF display does not dim when headlamps or park lamps are turned on, do Test D.
5. If one or more speakers do not operate, do Test E.
6. If the Subwoofer (K146) does not operate, do Test F.
7. If none of Remote Radio Waveband, Tune, Volume Up, or Volume Down Switches operate for the Mid Line Radio, do Test R.
8. If the Radio Waveband Switch (X234) does not operate, do Test J for the Mid Line Radio, Test N for the High Line Radio.
9. If the Radio Tune Switch (X233) does not operate, do Test K for the Mid Line Radio, Test O for the High Line Radio.
10. If the Radio Volume Up Switch (X235) does not operate, do Test L for the Mid Line Radio, Test P for the High Line Radio.
11. If the Radio Volume Down Switch (X236) does not operate, do Test M for the Mid Line Radio, Test Q for the High Line Radio.

**Test A**

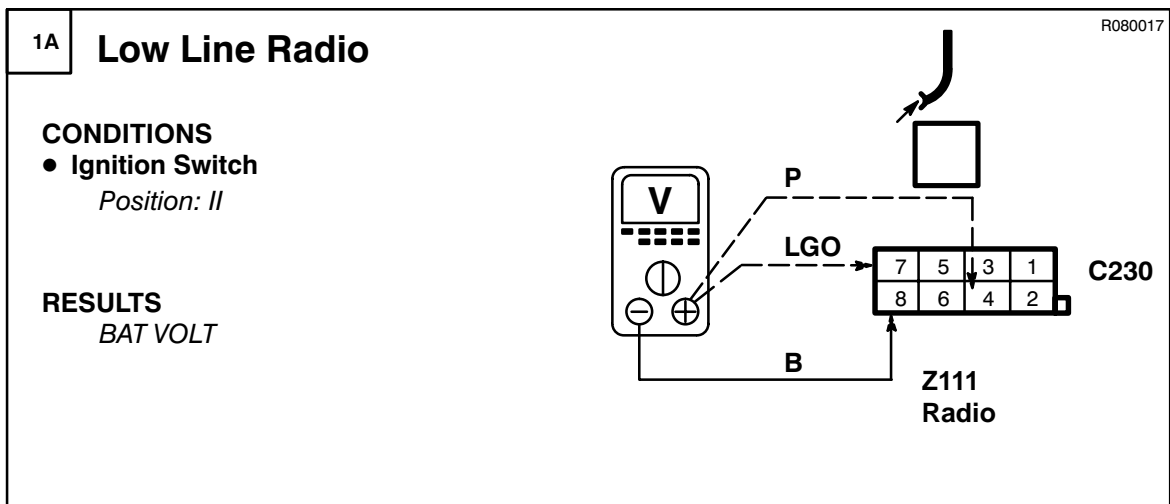

**PROBLEM CAUSE**

- P Wire
- LGO Wire
- F6 Fuse
- F3 Fuse
- B Wire



**PROBLEM CAUSE**

- Radio

**Test B**

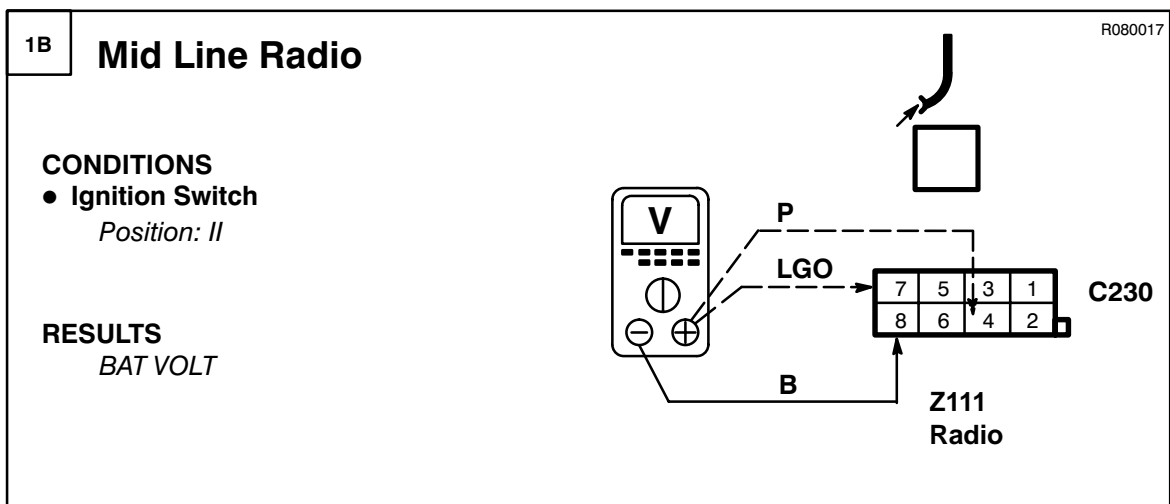

**PROBLEM CAUSE**

- P, LGO Wire
- F6 Fuse
- F3 Fuse
- B Wire

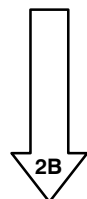

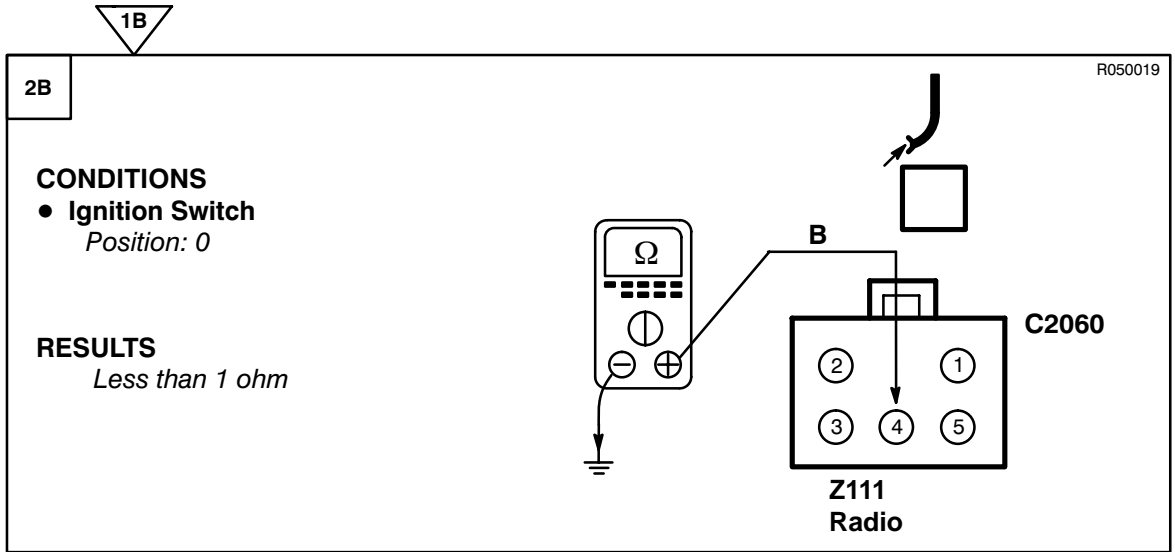

~~OK~~ PROBLEM CAUSE  
- B Wire

OK PROBLEM CAUSE  
- Radio

**Test C**

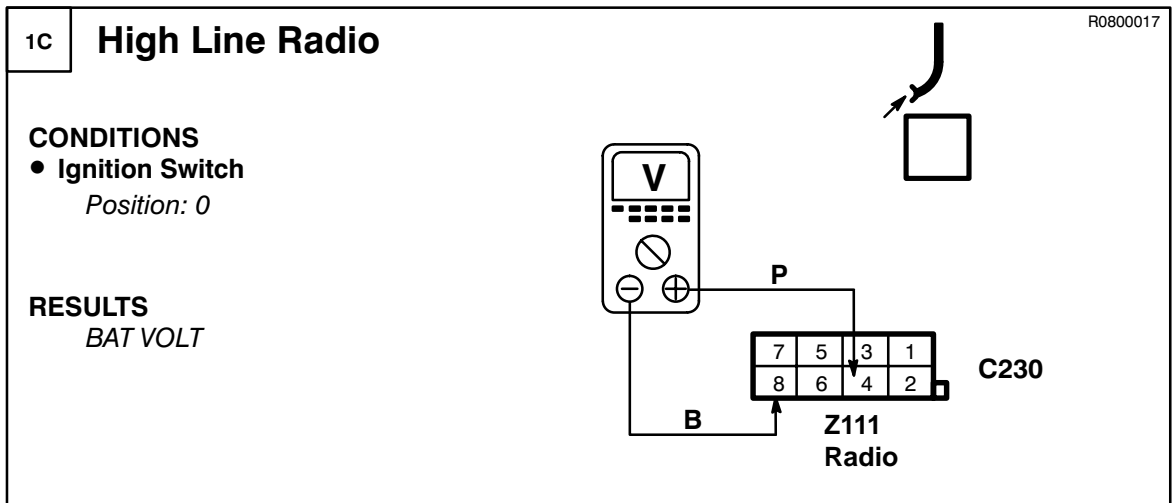

~~OK~~ PROBLEM CAUSE  
- P Wire  
- F6 Fuse  
- B Wire

OK

↓

2C

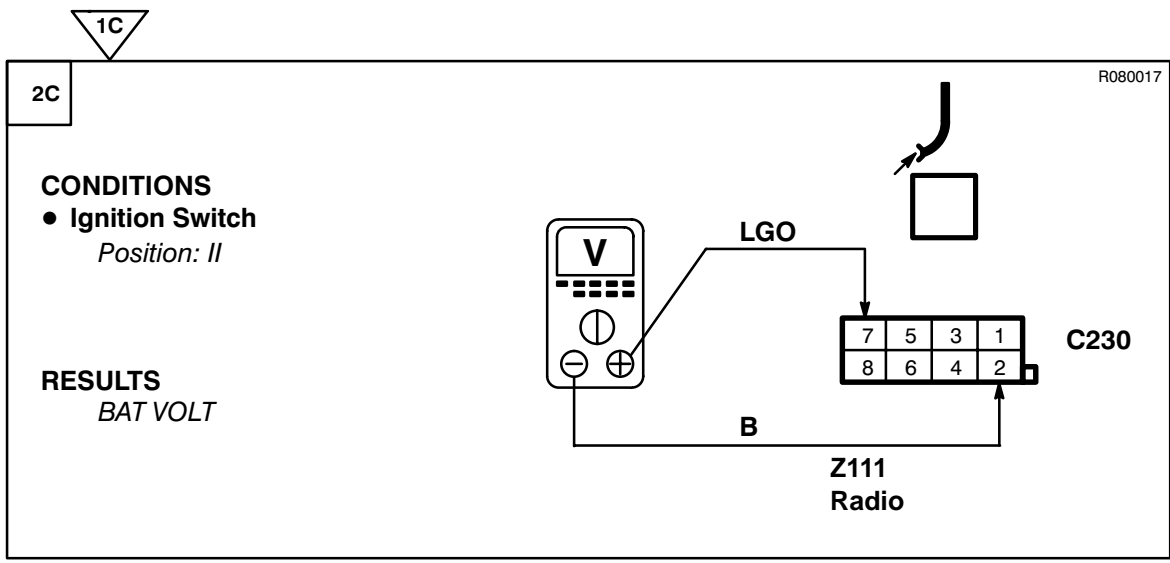

**PROBLEM CAUSE**

- LGO Wire
- F3 Fuse
- B Wire



**PROBLEM CAUSE**

- Radio

**Test D**

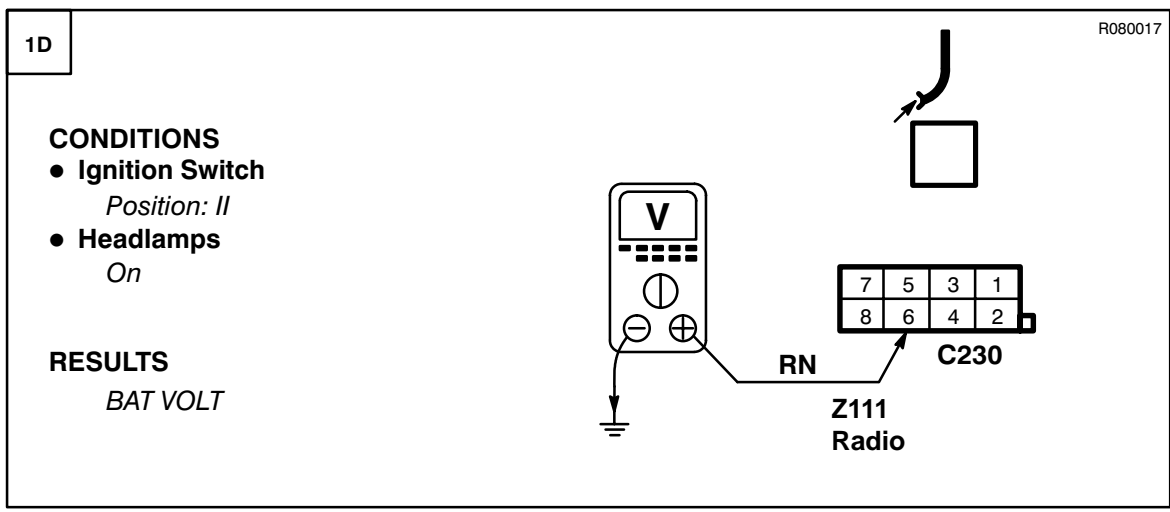

**PROBLEM CAUSE**

- RN Wire



**PROBLEM CAUSE**

- Radio

Test E

R010001

1E

**CONDITIONS**

- Connect at suspect connector
- Connect for less than 1 second

**RESULTS**

*Speaker 'pops'*

Speaker



**PROBLEM CAUSE**  
- Speaker



**PROBLEM CAUSE**  
- Speaker Wiring  
- Radio

Test F

R060012

1F

**CONDITIONS**

- Ignition Switch  
*Position: I*

**RESULTS**

*BAT VOLT*

LGO

C412

B

Z176  
Subwoofer Amplifier



**PROBLEM CAUSE**  
- LGO Wire  
- B Wire

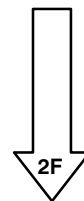



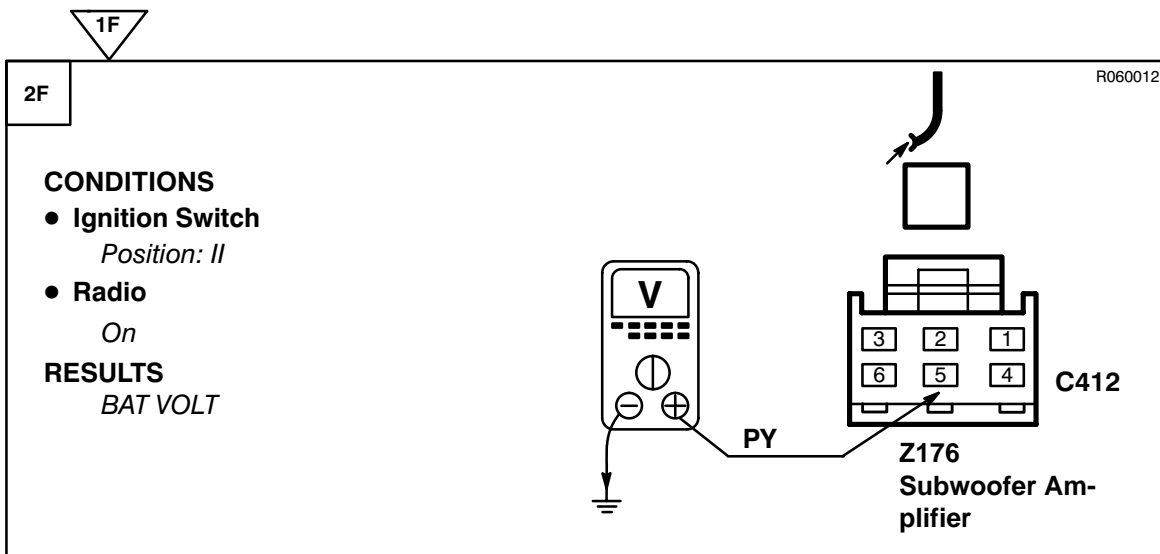

**PROBLEM CAUSE**

- UY Wire
- PY Wire
- Radio

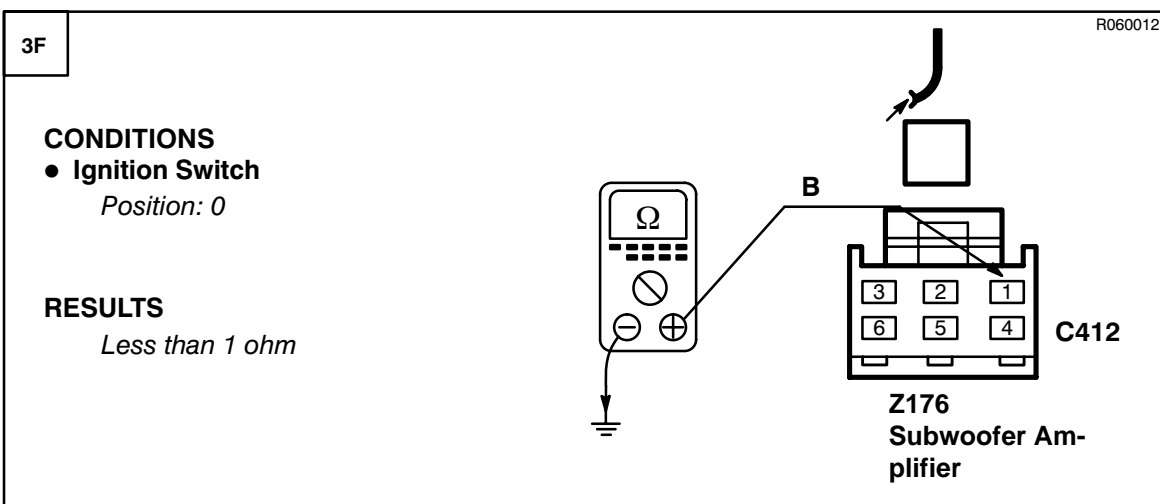
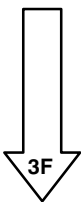

**PROBLEM CAUSE**

- B Wire

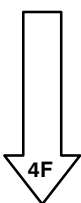

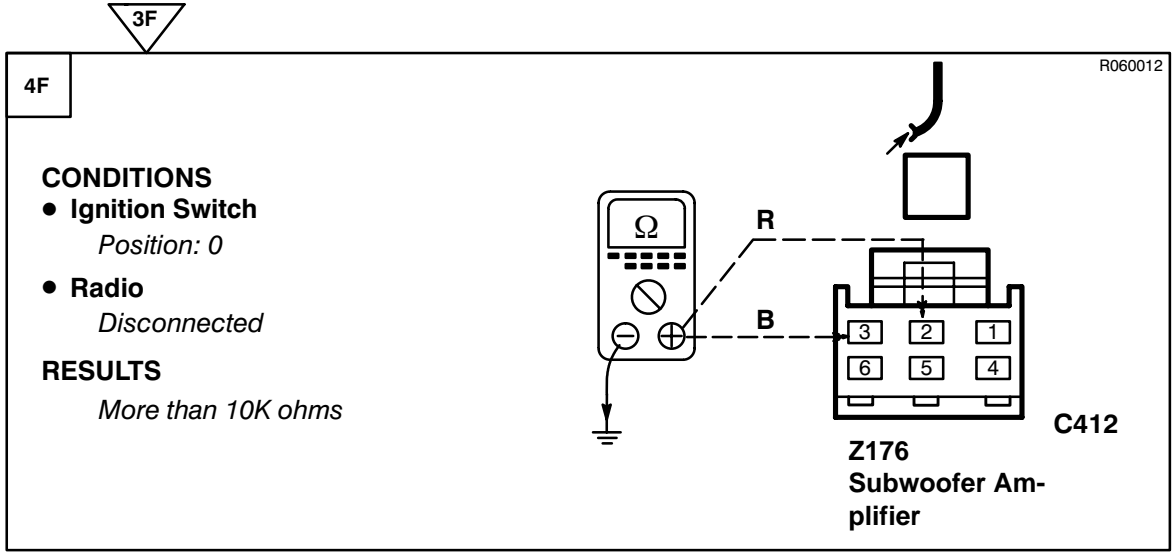

**PROBLEM CAUSE**

- R Wire
- B Wire



**MID LINE RADIO**  
GO TO TEST G  
**HIGH LINE RADIO**  
GO TO TEST H

**Test G**

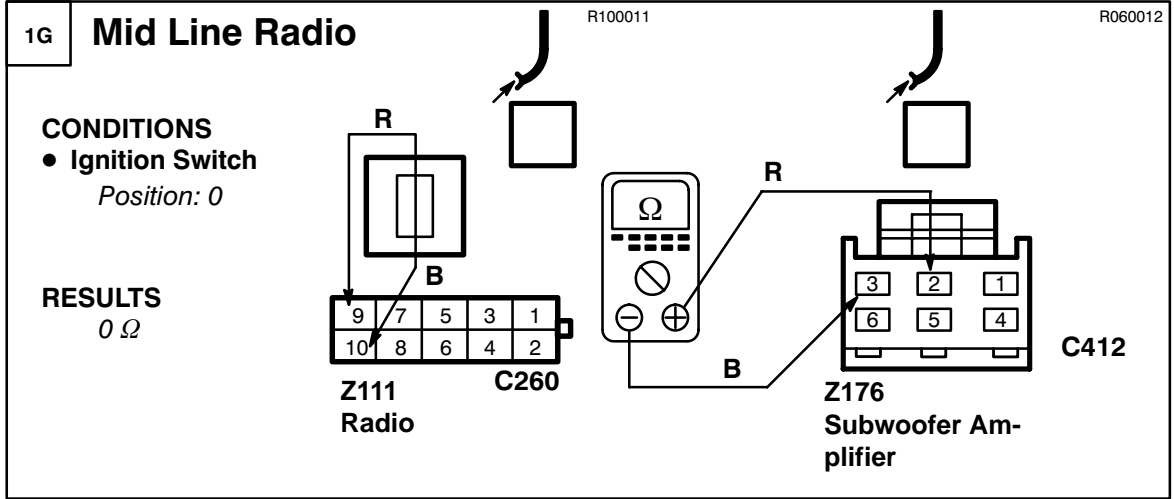

**PROBLEM CAUSE**

- R Wire
- B Wire



**GO TO TEST I**

**Test H**

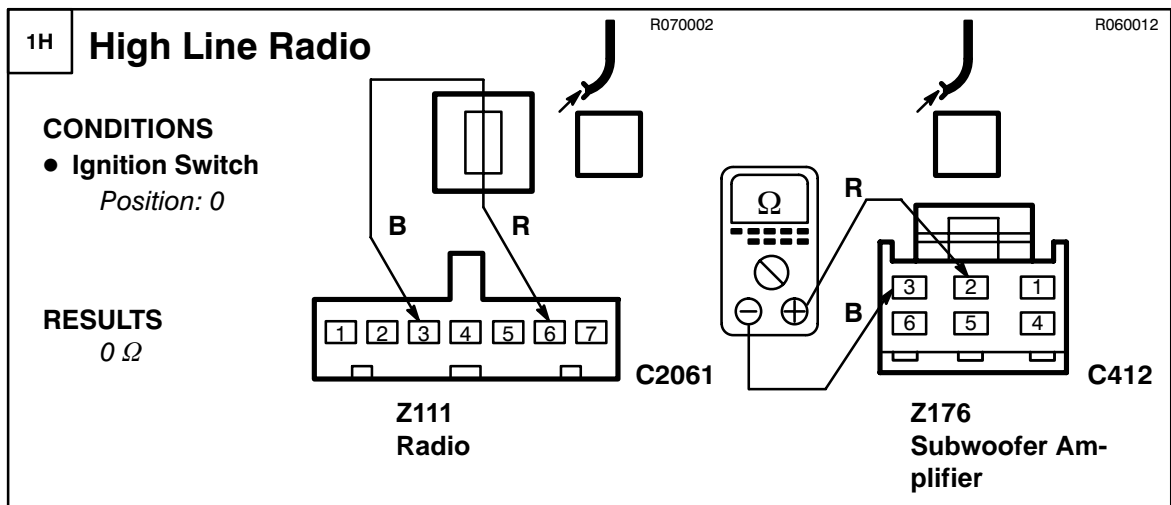

**PROBLEM CAUSE**

- R Wire
- B Wire



**GO TO TEST I**

**Test I**

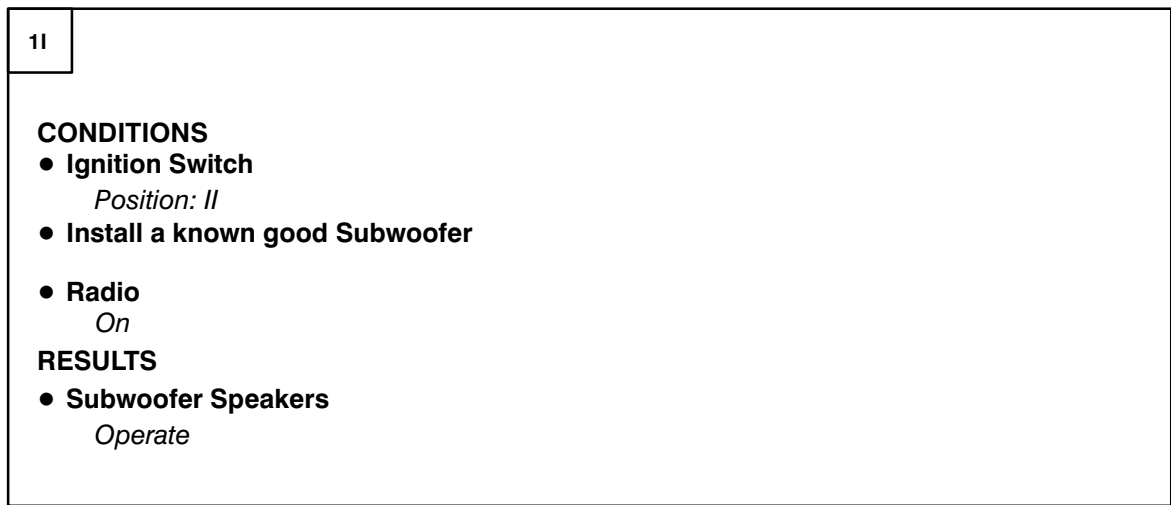

**PROBLEM CAUSE**

- Subwoofer Amplifier
- Radio
- Subwoofer Wiring



**PROBLEM CAUSE**

- Subwoofer

## Test J

**1J Mid Line Radio** R050019

**CONDITIONS**

- Ignition Switch  
*Position: 0*
- Radio Waveband Switch  
*On*

**RESULTS**  
*Less than 1 ohm*



**PROBLEM CAUSE**

- RK Wire
- B Wire
- Radio Waveband Switch



**PROBLEM CAUSE**

- Radio

## Test K

**1K Mid Line Radio** R050019

**CONDITIONS**

- Ignition Switch  
*Position: 0*
- Radio Tune Switch  
*On*

**RESULTS**  
*Less than 1 ohm*



**PROBLEM CAUSE**

- UG Wire
- B Wire
- Radio Tune Switch



**PROBLEM CAUSE**

- Radio

**Test L**

R050019

1L

### Mid Line Radio

**CONDITIONS**

- Ignition Switch  
*Position: 0*
- Radio Volume Up Switch  
*On*

**RESULTS**  
*Less than 1 ohm*

**Z111 Radio**  
C2060



- PROBLEM CAUSE**
- NY Wire
  - B Wire
  - Radio Volume Up Switch



- PROBLEM CAUSE**
- Radio

**Test M**

R050019

1M

### Mid Line Radio

**CONDITIONS**

- Ignition Switch  
*Position: 0*
- Radio Volume Down Switch  
*On*

**RESULTS**  
*Less than 1 ohm*

**Z111 Radio**  
C2060



- PROBLEM CAUSE**
- U Wire
  - B Wire
  - Radio Volume Down Switch



- PROBLEM CAUSE**
- Radio

**Test N**

**1N High Line Radio** R050002.02

**CONDITIONS**

- Ignition Switch  
*Position: 0*
- Radio Waveband Switch  
*On*

**RESULTS**  
*Less than 1 ohm*

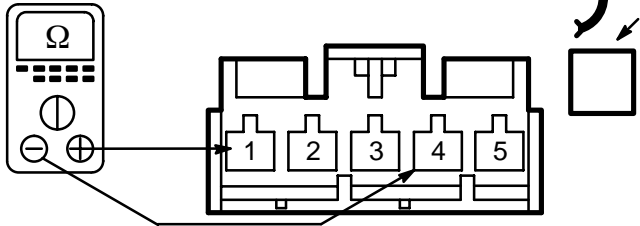

**X234  
Radio Waveband  
Switch**



**PROBLEM CAUSE**  
- Radio Waveband  
Switch



**PROBLEM CAUSE**  
- Radio Waveband Resistor  
- Radio Tune Resistor  
- Radio Volume Resistor  
- RG, UG, NY, U, B Wire  
- Radio

**Test O**

**10 High Line Radio** R050002.02

**CONDITIONS**

- Ignition Switch  
*Position: 0*
- Radio Tune Switch  
*On*

**RESULTS**  
*Less than 1 ohm*

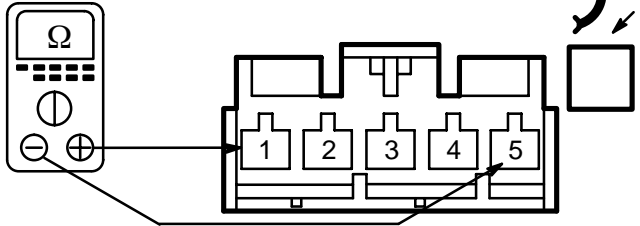

**X233  
Radio Tune  
Switch**



**PROBLEM CAUSE**  
- Radio Tune  
Switch



**PROBLEM CAUSE**  
- Radio Tune Resistor  
- Radio Volume Resistor  
- UG, NY, U, B Wire  
- Radio

**Test P**

1P

### High Line Radio

R050002.02

**CONDITIONS**

- Ignition Switch  
*Position: 0*
- Radio Volume Up Switch  
*On*

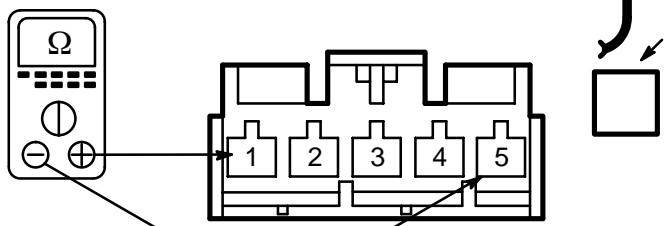

**X235  
Radio Volume Up  
Switch**

**RESULTS**  
*Less than 1 ohm*



**PROBLEM CAUSE**  
- Radio Volume Up  
Switch



**PROBLEM CAUSE**  
- Radio Volume Resistor  
- NY, U, B Wire  
- Radio

**Test Q**

1Q

### High Line Radio

R050002.02

**CONDITIONS**

- Ignition Switch  
*Position: 0*
- Radio Volume Down Switch  
*On*

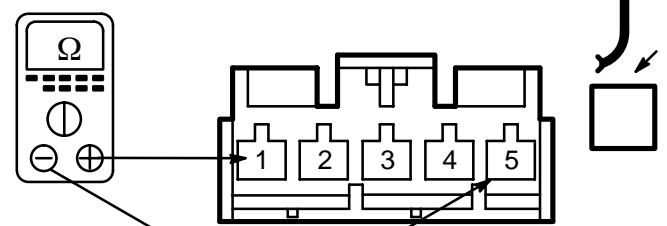

**X236  
Radio Volume  
Down Switch**

**RESULTS**  
*Less than 1 ohm*



**PROBLEM CAUSE**  
- Radio Volume  
Down Switch



**PROBLEM CAUSE**  
- U,B Wire  
- Radio

Test R

1R **Mid Line Radio** R050019

**CONDITIONS**

- Ignition Switch  
*Position: 0*

**RESULTS**  
*Less than 1 ohm*

**Z111  
Radio**



**PROBLEM CAUSE**  
- B Wire



**PROBLEM CAUSE**  
- Radio



## CIRCUIT OPERATION

The audio system consists of a new head unit connected to a Radio Tune Switch, a waveband switch, a volume up and a volume down switch which are located on the fascia next to the Instrument Cluster. The system is also equipped with an amplifier, a subwoofer, a subwoofer amplifier and a CD changer which is connected to the Radio with a DIN cable. The amplifier is connected to power via a Power Amplifier Relay which is energized with Ignition on.

The control head is equipped with an anti-theft feature which makes the unit inoperative once battery power is removed. A security code must be entered to restore power to the unit. The system is equipped with two rear and two front speakers.

Battery voltage is provided to the control head at all times through the P wire. In addition to monitoring the anti-theft feature, this input keeps the preset station memory alive. Whenever battery power to the unit is lost, the anti-theft code must be entered and the preset stations must be reprogrammed.

When the Radio (Z111) and the ignition are turned on, the voltage signal through the LGO wire and the control head 'wakes up' the unit. The Radio (Z111) plays, the VF display comes on and the control unit buttons illuminate. The VF display is dimmed when the headlights or park lights are turned on. When the lights are on, voltage from fuse F8 of the Fascia Fusebox (P126) is applied to the Radio (Z111) terminal 6, Connector 230 signalling the Radio (Z111) to dim the display.

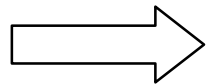
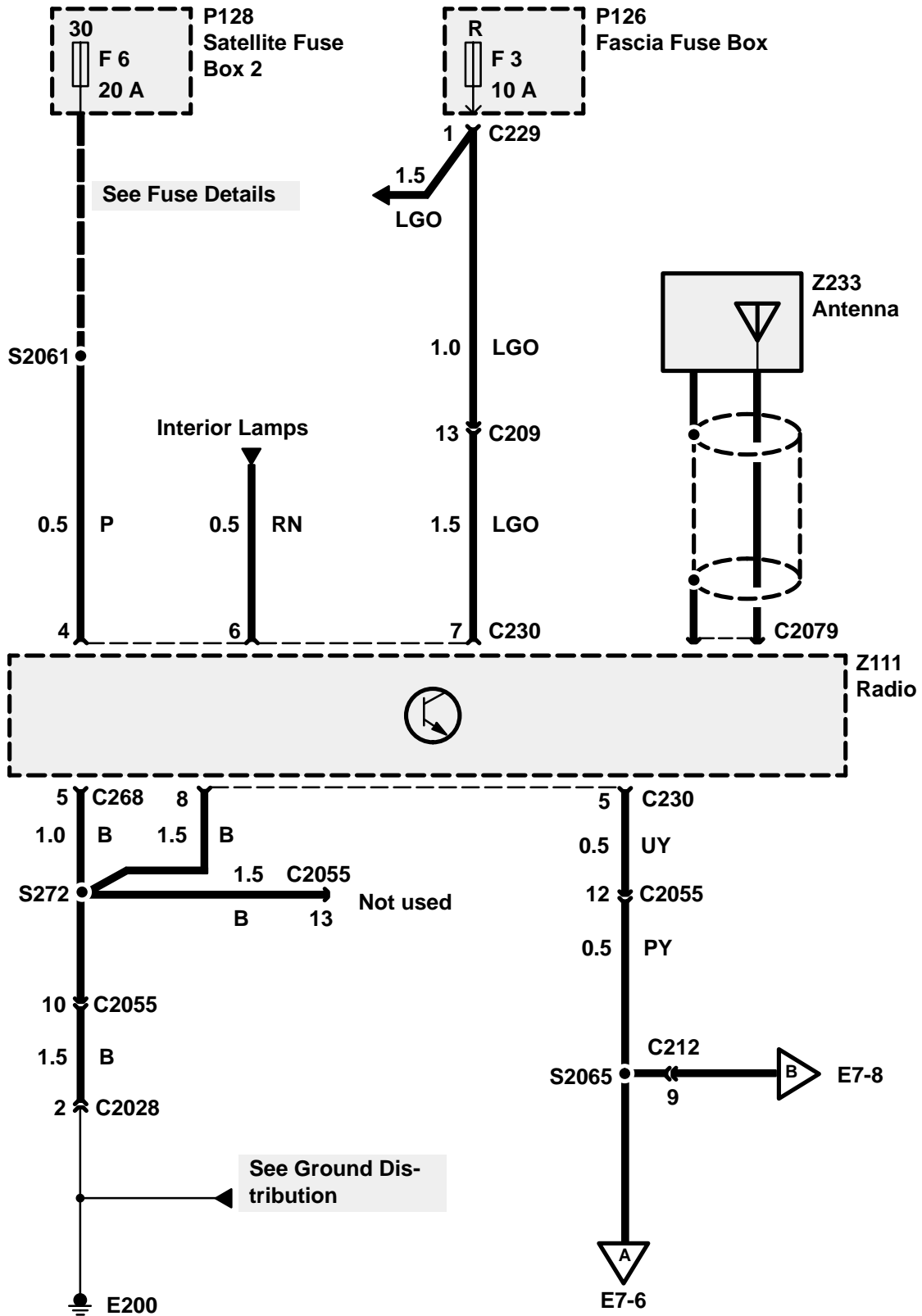

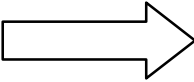
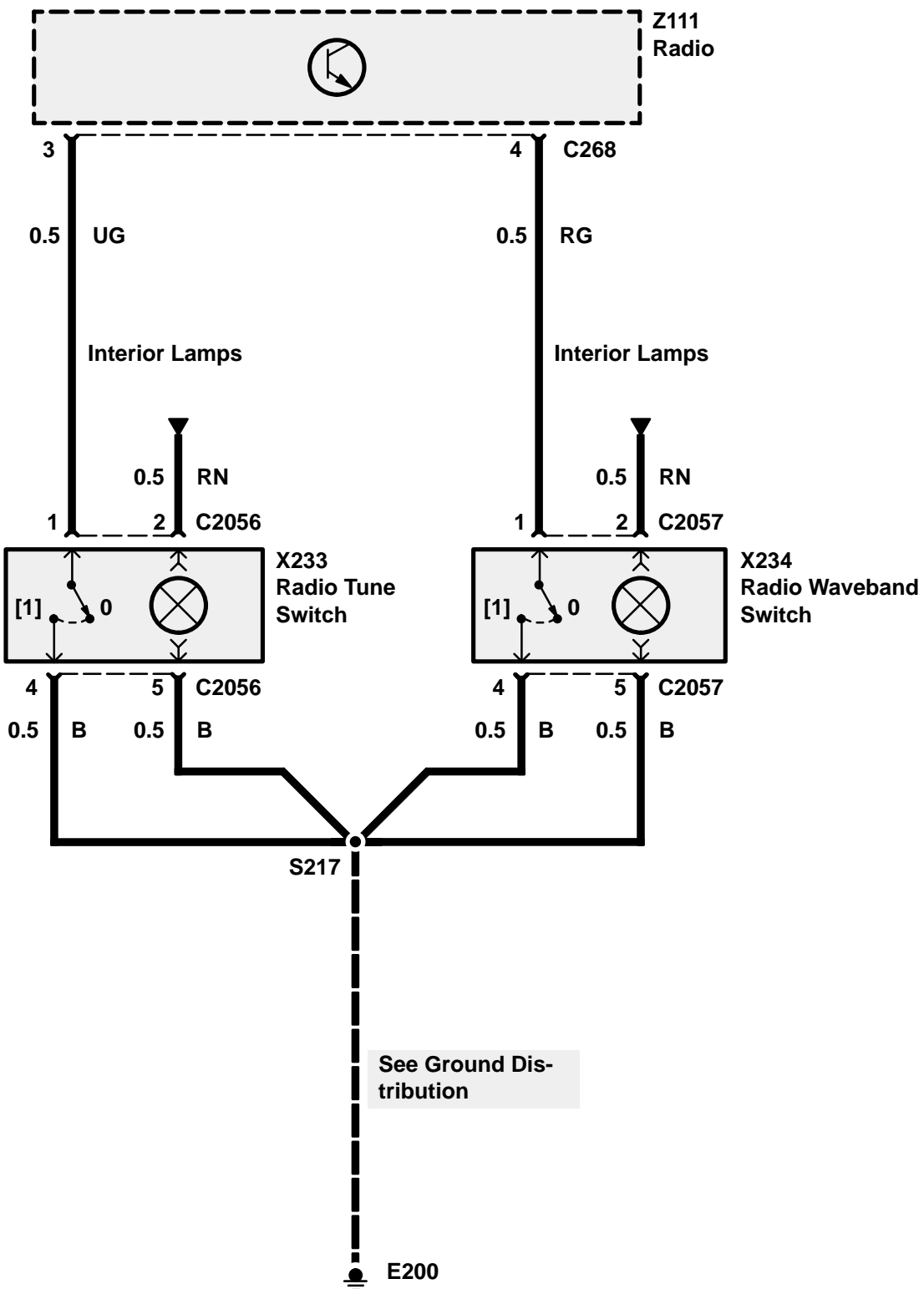
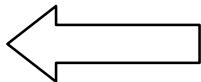

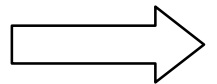
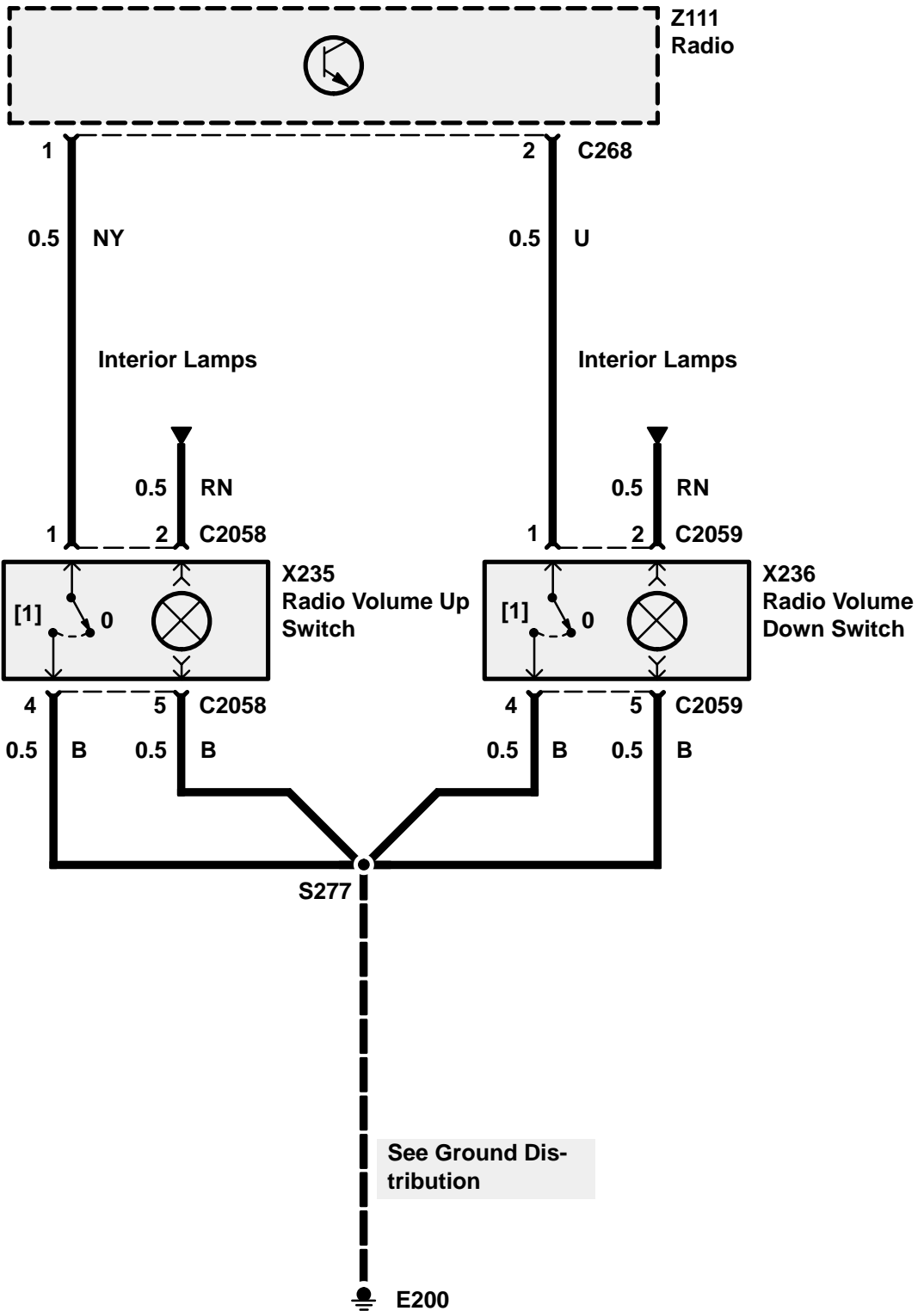
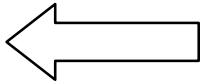

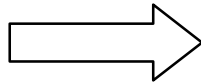
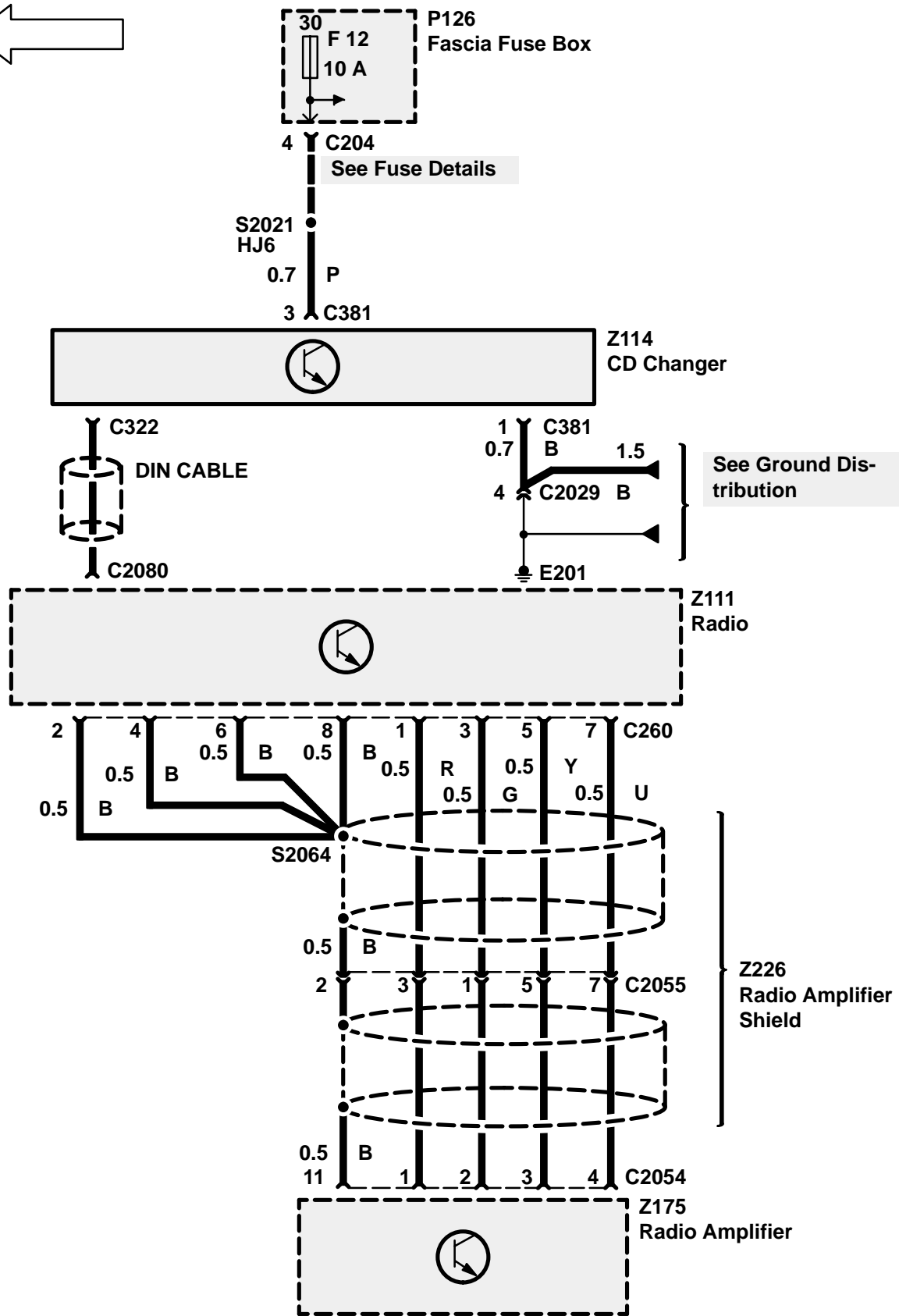
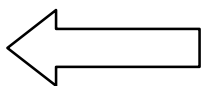

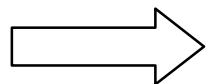
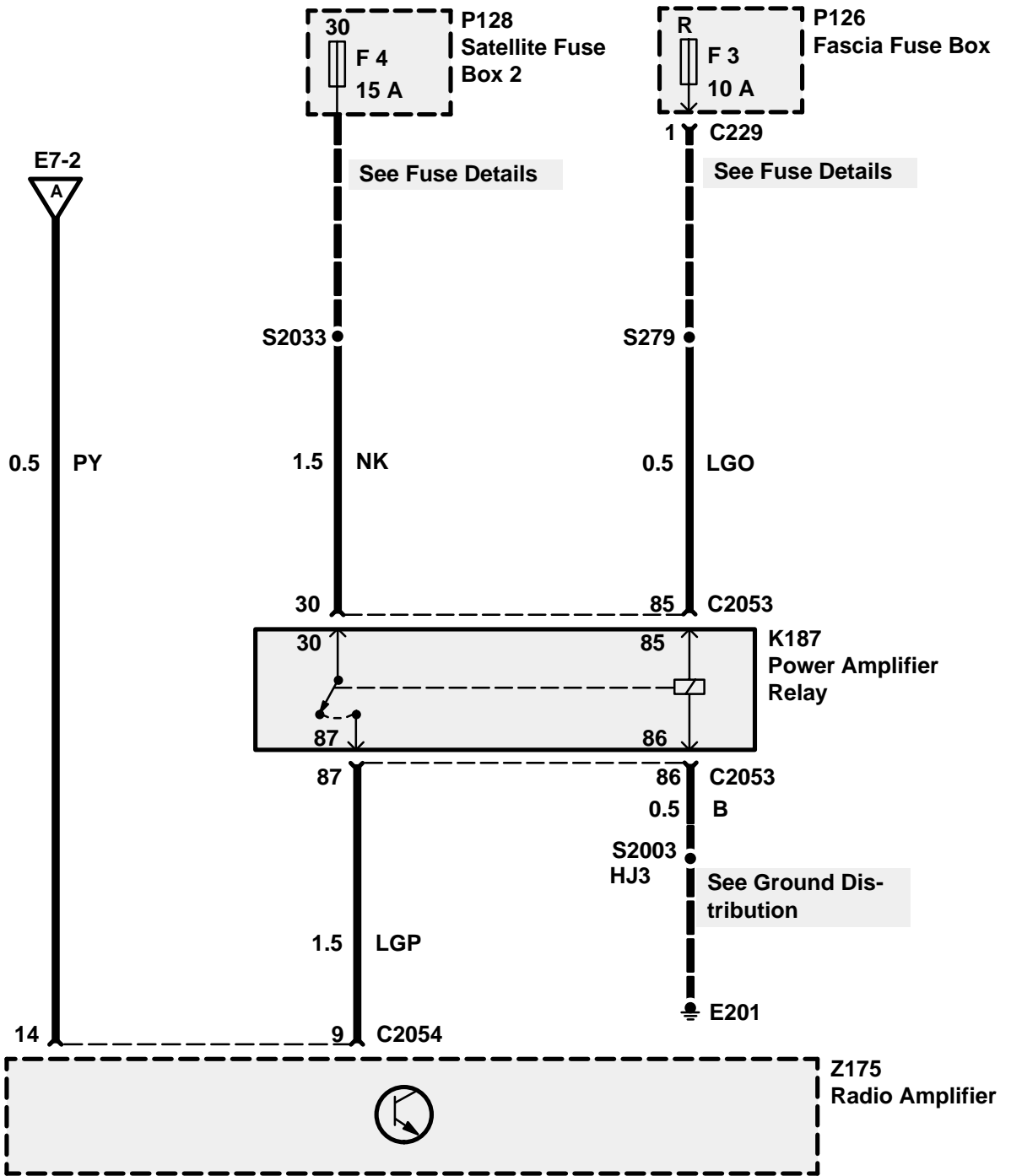
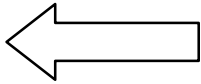

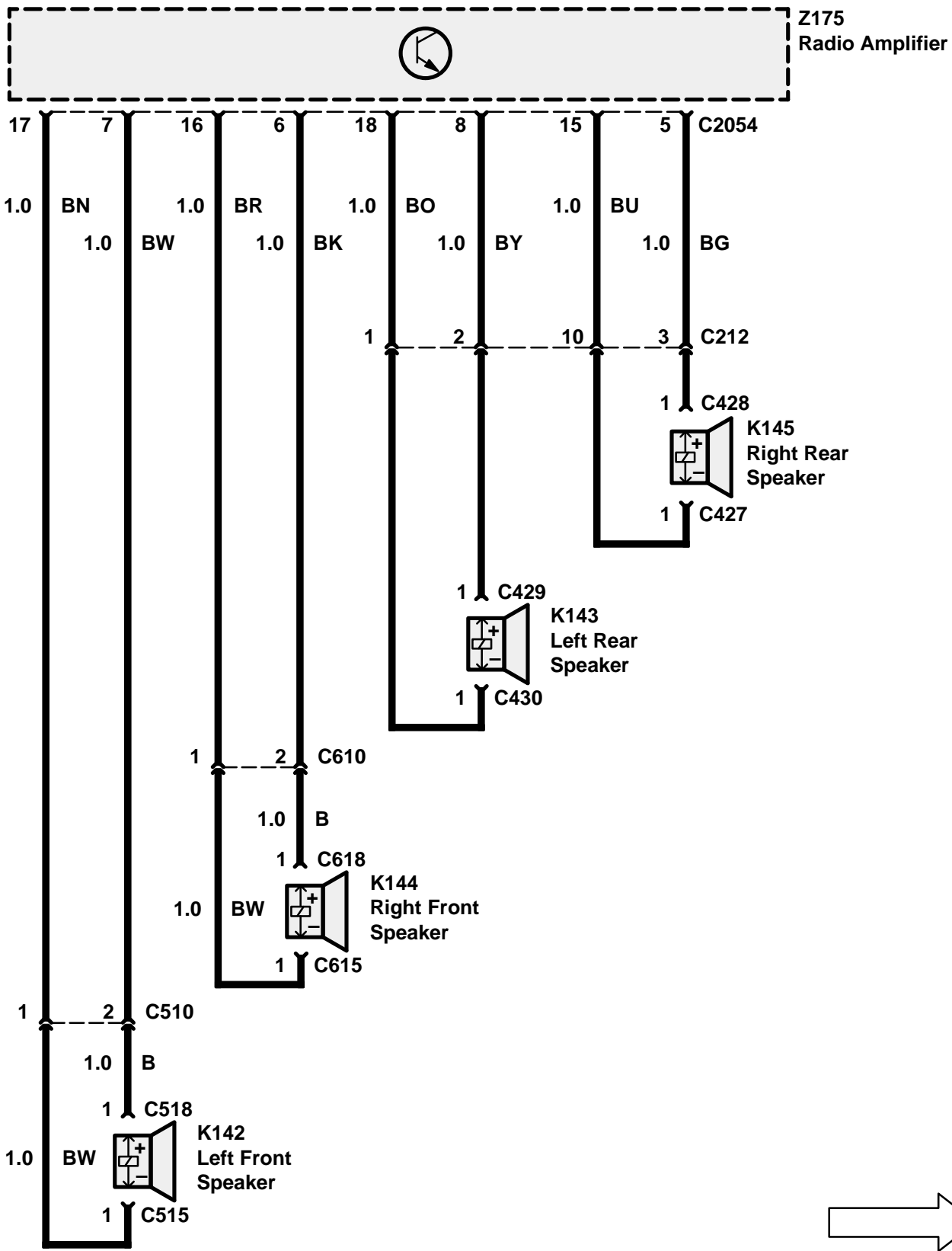
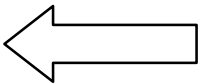

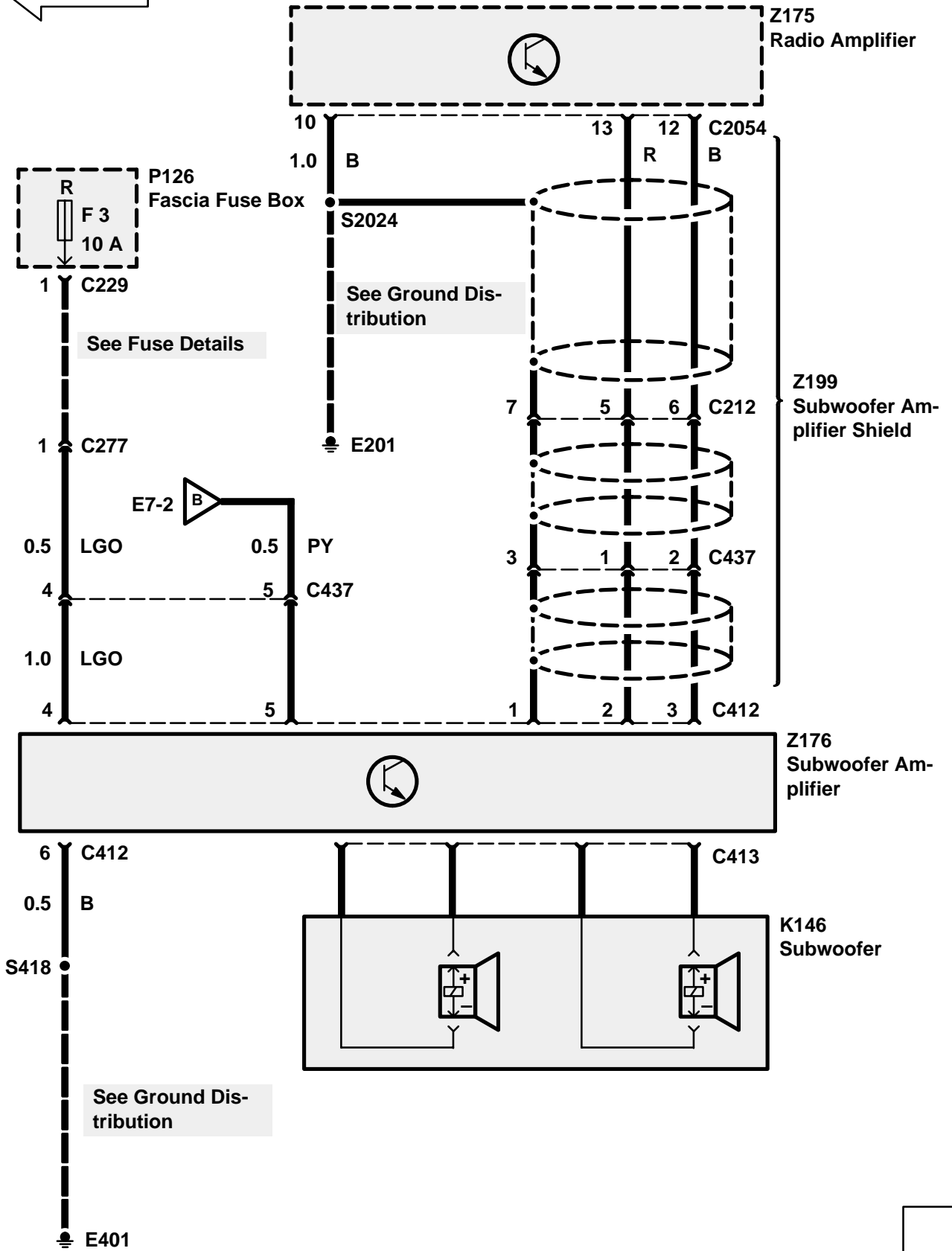
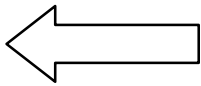



**TROUBLESHOOTING HINTS**

12. Check fuses F6 of Satellite Fusebox 2 (P128) and F3 of Fascia Fusebox (P126).
13. Check that Radio (Z111) connectors and coaxial cable are tight and properly connected.
14. For proper Radio (Z111) noise diagnosis, take the vehicle outside where signals are strong. Close the hood and keep away from metal buildings or other sources of Radio interference.
15. If Radio (Z111) noise is excessive when an accessory is on, install a Radio noise suppression capacitor to the power lead of that accessory.
16. If Radio (Z111) noise is excessive at all times, check antenna wiring. If OK, check spark plugs, spark plug wiring and wiring close to the ignition system which could transmit noise to the Radio (Z111) wiring.
17. If only the CD Changer does not operate, check power, ground, and DIN Cable. If OK, check Radio and CD Changer.
18. If the Radio (Z111) is inoperative and 'code' is being shown on the display, follow the instructions below.
19. If Radio scans past all frequencies when in seek mode and hiss is present over most stations, substitute antenna with a known good antenna. If the reception is still inadequate, replace Radio.

**Security Code Instructions**

1. Obtain 5-digit security code from vehicle owner or manufacturer.
2. Enter the code number using the Radio (Z111) push-button selectors.

NOTE: If the correct code is not entered in 3 successive attempts, the Radio (Z111) will not accept another entry until the Radio has been left on for 1 hour with the ignition on.

NOTE: When entering the code, be sure to complete the sequence numbering of that 5-digit code even if you made a mistake. For example, if the correct code number sequence is 43215 and you mistakenly enter 42 instead of 43, continue the code number sequence of 215 to complete that entry. A 'beep' will sound, 'code' will still be displayed and the Radio will not operate. Re-enter the correct code 43215 and the Radio will operate.

NOTE: If an audible 'beep' is heard while entering the code, STOP immediately. Begin entering the code again, starting with the first number of the 5-digit code.

NOTE: If a push-button is touched accidentally when the ignition is off, a warning tone will sound. Turn the ignition on and the tone will stop.

**SYSTEM DIAGNOSIS**

1. If the Radio (Z111) does not operate at all, do Test A.
2. If VF display does not dim when head lamps or park lamps are turned on, do Test B.
3. If one or more speakers do not operate, do Test C.
4. If the Radio (Z111) appears to operate properly, but the Subwoofer (K146) and/or none of the Speakers operate, do Test D.
5. If the Subwoofer (K146) does not operate, do Test E.
6. If none of the Remote Radio Waveband, Tune, Volume Up, or Volume Down Switches operate for the Mid Line Radio, do Test J.
7. If the Radio Waveband Switch (X234) does not operate, do Test F.
8. If the Radio Tune Switch (X233) does not operate, do Test G.
9. If the Radio Volume Up Switch (X235) does not operate, do Test H.
10. If the Radio Volume Down Switch (X236) does not operate, do Test I.

**Test A**

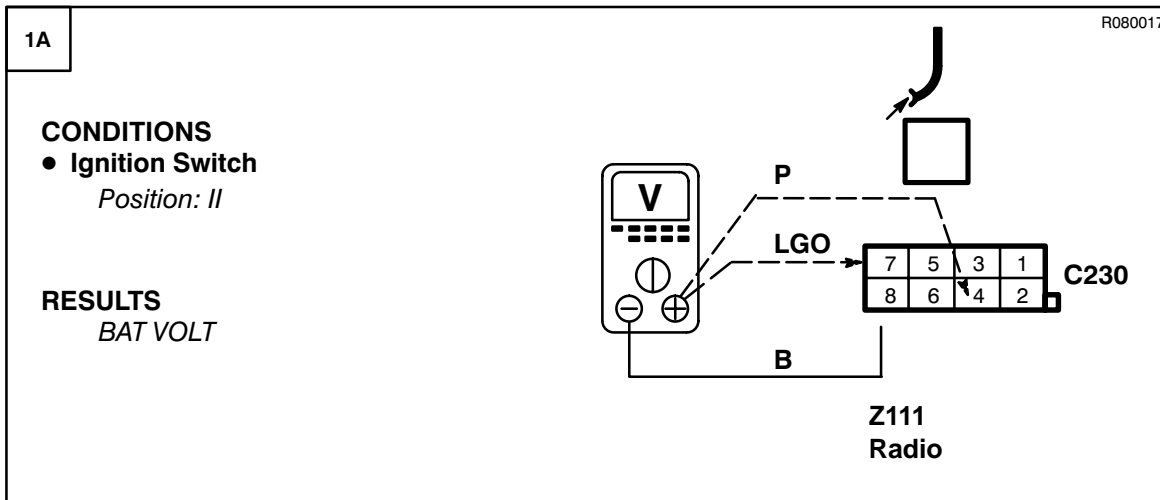

**PROBLEM CAUSE**

- P Wire
- LGO Wire
- F6 Fuse
- F3 Fuse
- B Wire

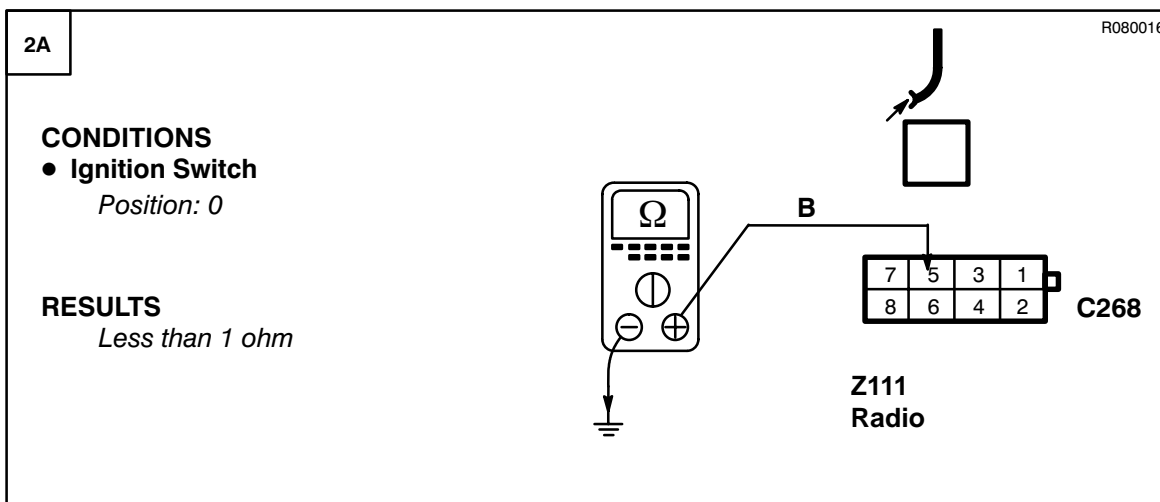

**PROBLEM CAUSE**

- B Wire



**PROBLEM CAUSE**

- Radio

**Test B**

R080017

1B

**CONDITIONS**

- Ignition Switch  
*Position: II*
- Headlamps  
*On*

**RESULTS**  
*BAT VOLT*

RN  
Z111  
Radio



**PROBLEM CAUSE**  
- RN Wire



**PROBLEM CAUSE**  
- Radio

**Test C**

R010001

1C

**CONDITIONS**

- Connect at suspect connector
- Connect for less than 1 second

**RESULTS**  
*Speaker 'pops'*

Speaker



**PROBLEM CAUSE**  
- Speaker



**PROBLEM CAUSE**  
- Speaker Wiring  
- Radio

**Test D**

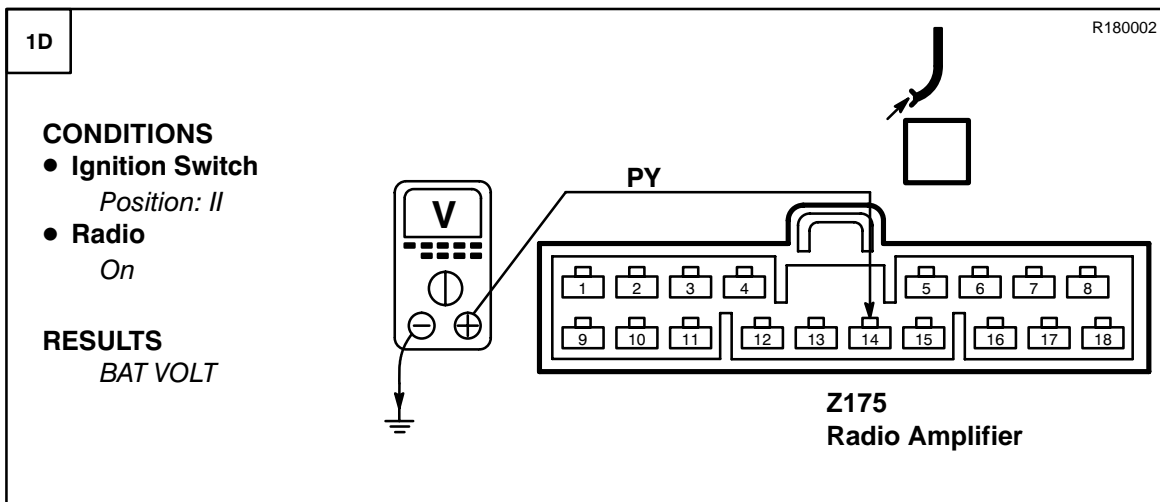

**PROBLEM CAUSE**

- UY Wire
- PY Wire
- Radio

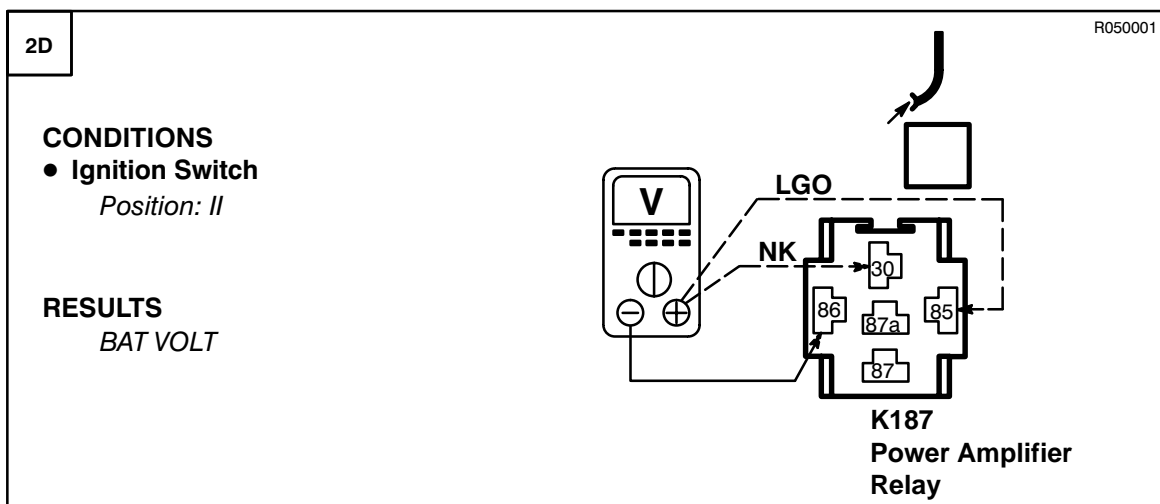
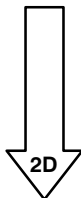

**PROBLEM CAUSE**

- F4 Fuse
- F3 Fuse
- NK Wire
- LGO Wire
- B Wire

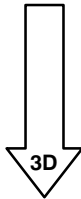

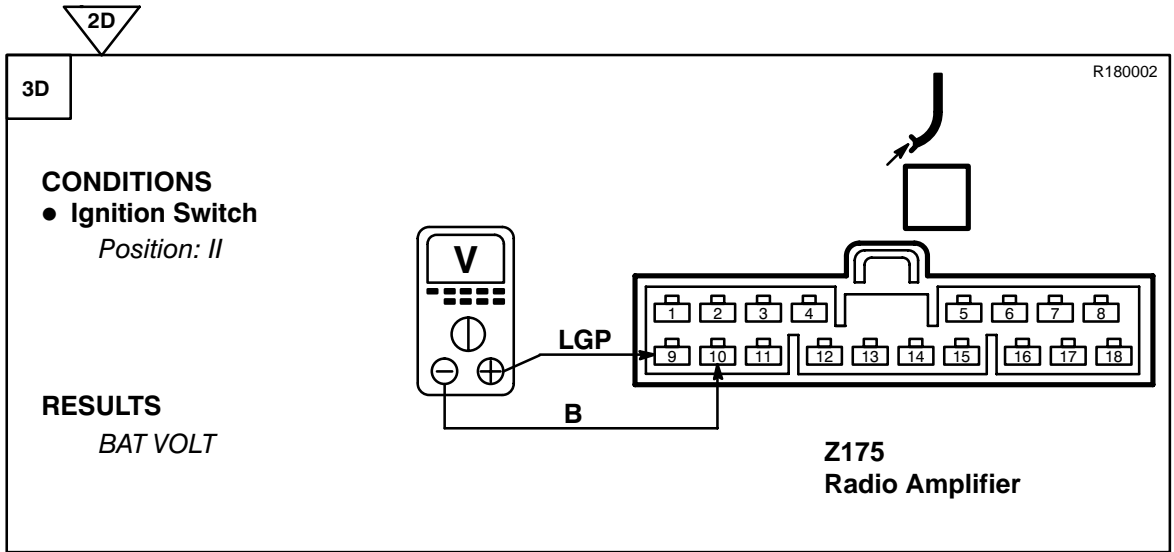

**PROBLEM CAUSE**

- LGP Wire
- B Wire
- Power Amplifier Relay

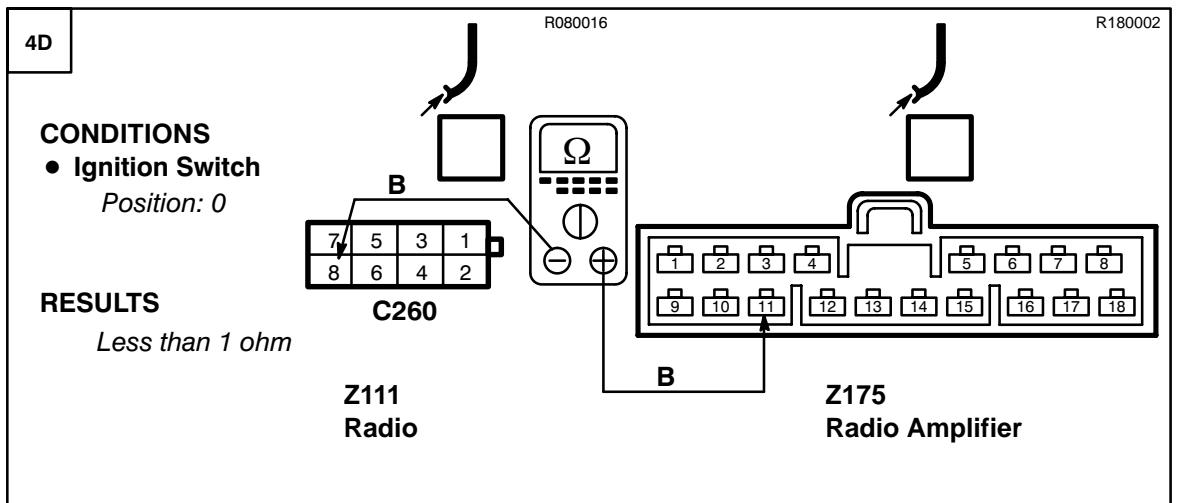
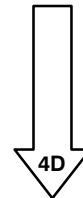

**PROBLEM CAUSE**

- B Wire



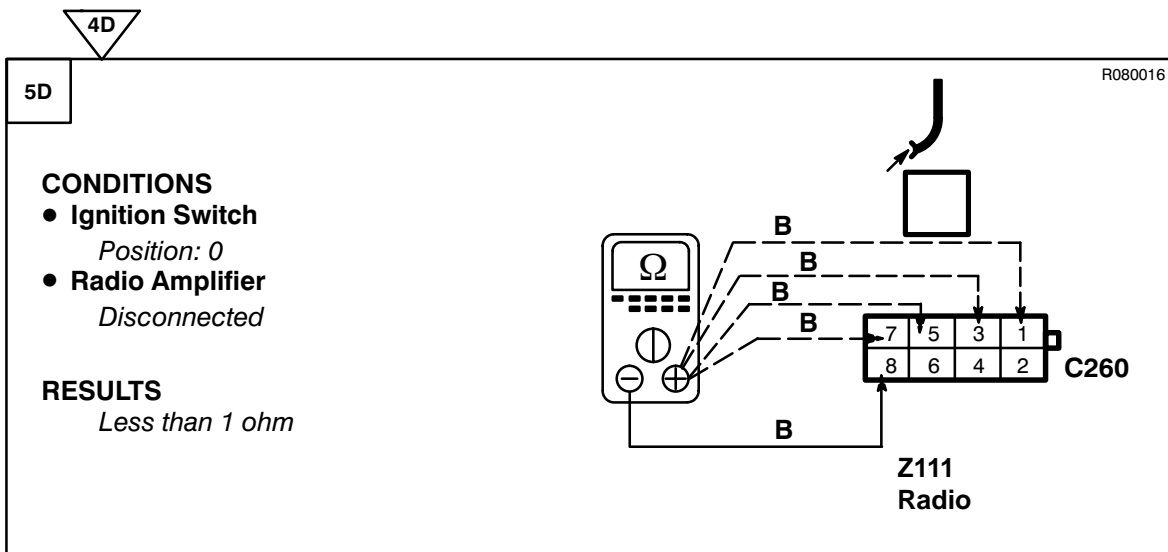

~~OK~~ **PROBLEM CAUSE**  
- B Wire

OK

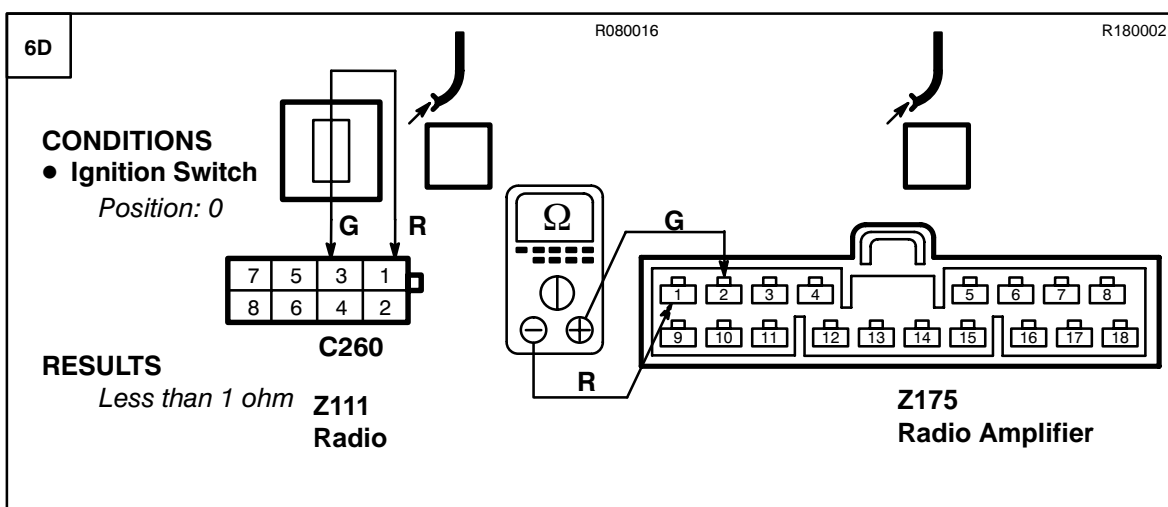
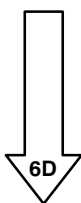

~~OK~~ **PROBLEM CAUSE**  
- G Wire  
- R Wire

OK

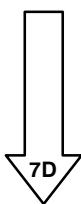

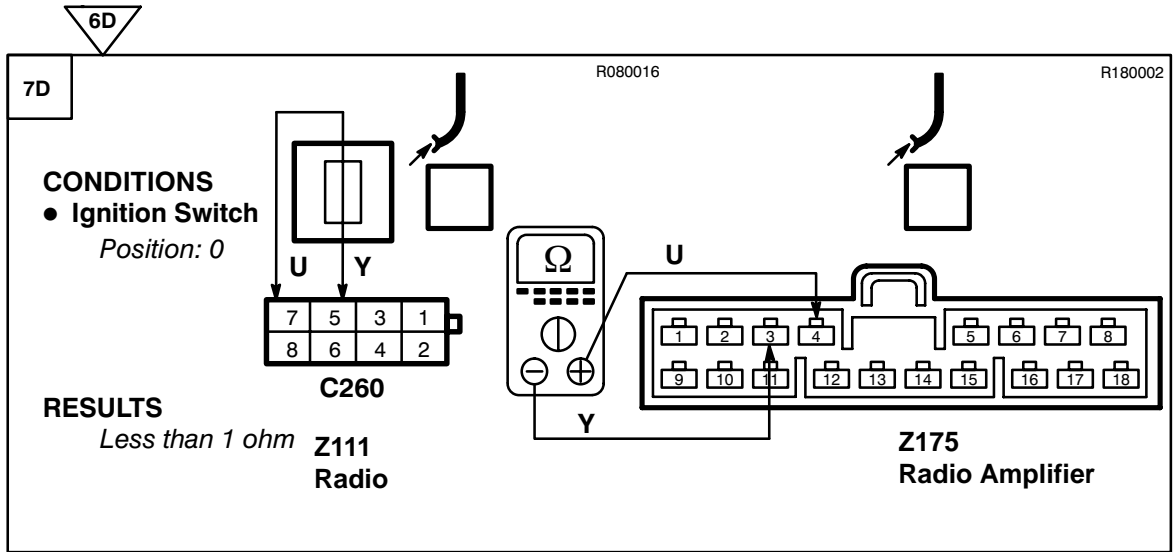

**PROBLEM CAUSE**

- U Wire
- Y Wire



**PROBLEM CAUSE**

- Radio
- Radio Amplifier

**Test E**

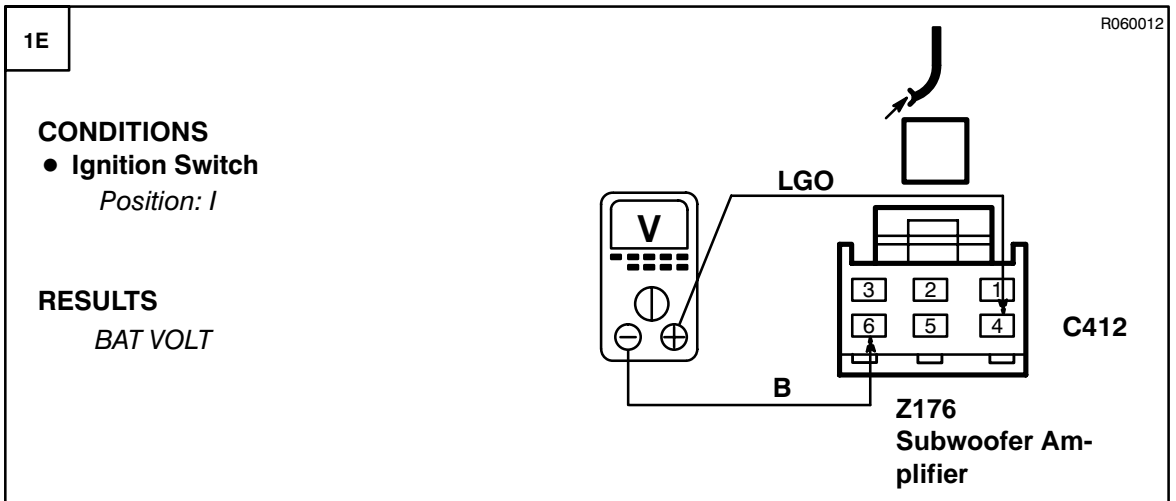

**PROBLEM CAUSE**

- LGO Wire
- B Wire

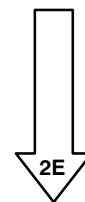



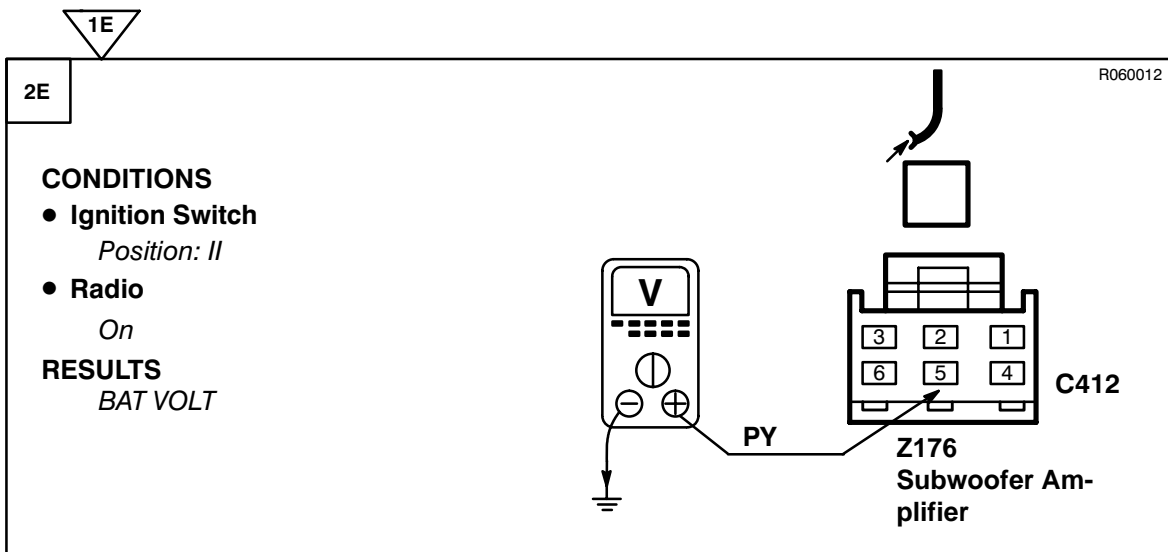

~~OK~~ **PROBLEM CAUSE**  
- PY Wire

OK

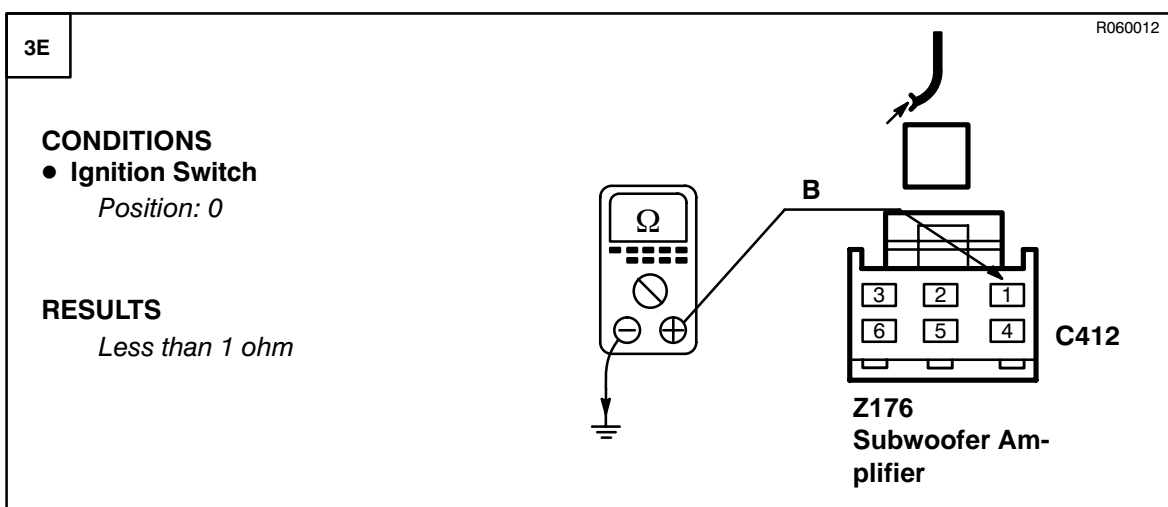
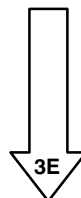

~~OK~~ **PROBLEM CAUSE**  
- B Wire

OK

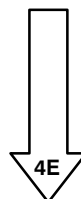

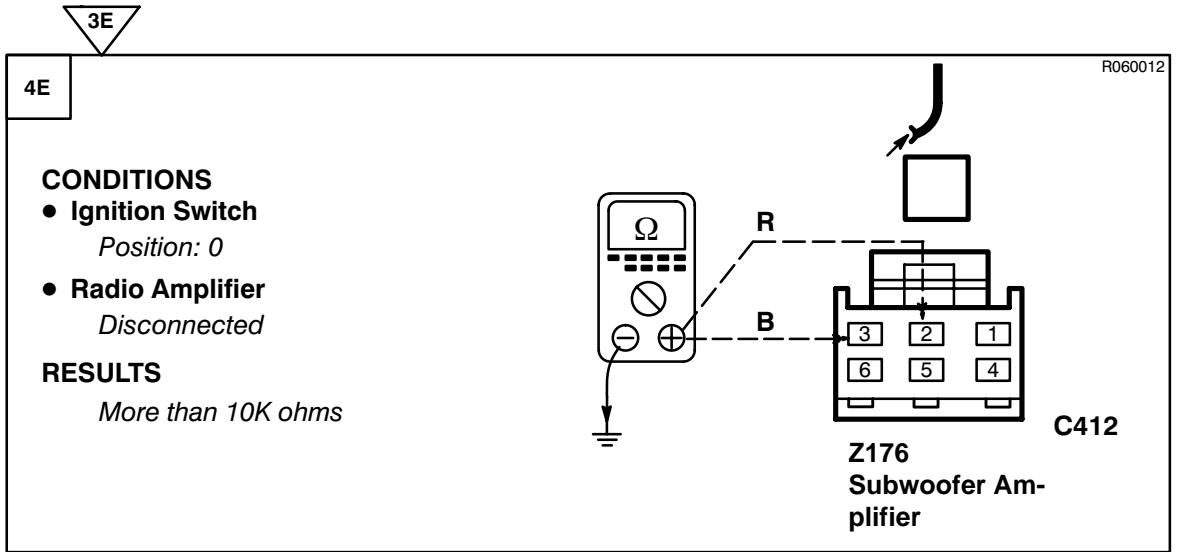

**PROBLEM CAUSE**

- R Wire
- B Wire

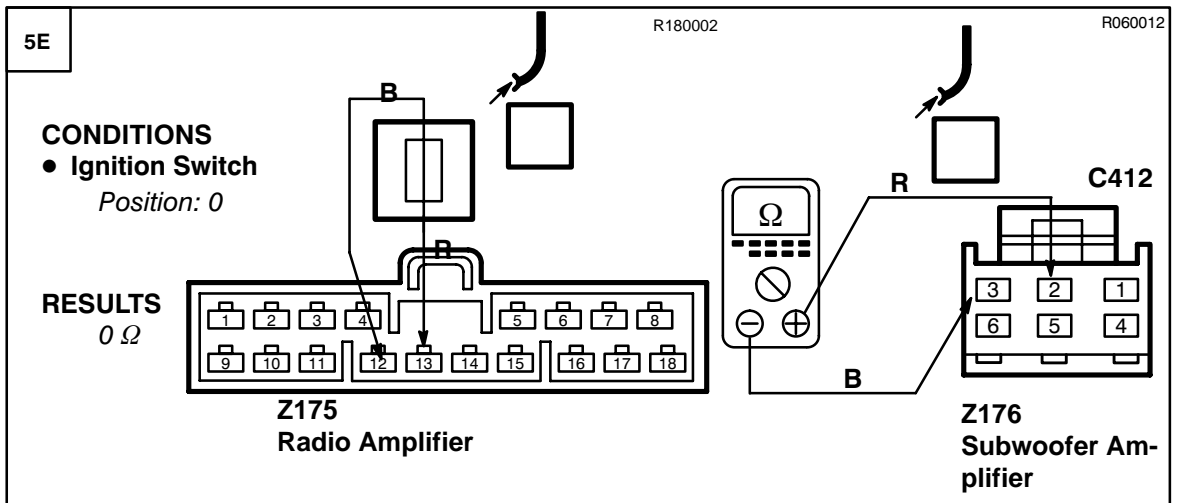
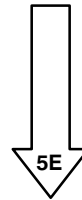

**PROBLEM CAUSE**

- R Wire
- B Wire

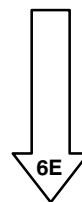

5E

6E

**CONDITIONS**

- Ignition Switch  
*Position: II*
- Install a known good Subwoofer
- Radio  
*On*

**RESULTS**

- Subwoofer Speakers  
*Operate*



**PROBLEM CAUSE**

- Subwoofer Amplifier
- Radio
- Subwoofer Wiring



**PROBLEM CAUSE**

- Subwoofer

**Test F**

1F

**CONDITIONS**

- Ignition Switch  
*Position: 0*
- Radio Waveband Switch  
*On*

**RESULTS**

*Less than 1 ohm*

R080016



**PROBLEM CAUSE**

- RG Wire
- B Wire
- Radio Waveband Switch



**PROBLEM CAUSE**

- Radio

**Test G**

1G

R080016

**CONDITIONS**

- Ignition Switch  
Position: 0
- Radio Tune Switch  
On

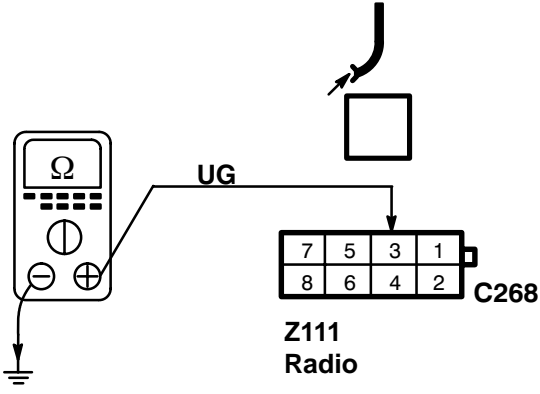

**RESULTS**  
Less than 1 ohm

**PROBLEM CAUSE**

- UG Wire
- B Wire
- Radio Tune Switch

**PROBLEM CAUSE**

- Radio

**Test H**

1H

R080016

**CONDITIONS**

- Ignition Switch  
Position: 0
- Radio Volume Up Switch  
On

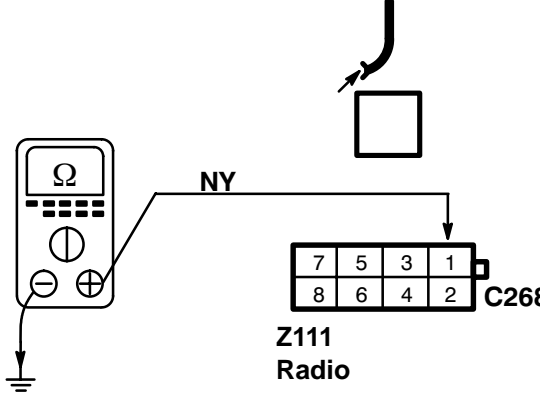

**RESULTS**  
Less than 1 ohm

**PROBLEM CAUSE**

- NY Wire
- B Wire
- Radio Volume Up Switch

**PROBLEM CAUSE**

- Radio

**Test I**

R080016

1I

**CONDITIONS**

- Ignition Switch  
*Position: 0*
- Radio Volume Down Switch  
*On*

**RESULTS**  
*Less than 1 ohm*

**Z111 Radio**

**C268**



**PROBLEM CAUSE**

- U Wire
- B Wire
- Radio Volume Down Switch



**PROBLEM CAUSE**

- Radio

**Test J**

R080016

1J

**CONDITIONS**

- Ignition Switch  
*Position: 0*

**RESULTS**  
*Less than 1 ohm*

**Z111 Radio**

**C268**



**PROBLEM CAUSE**

- B Wire



**PROBLEM CAUSE**

- Radio

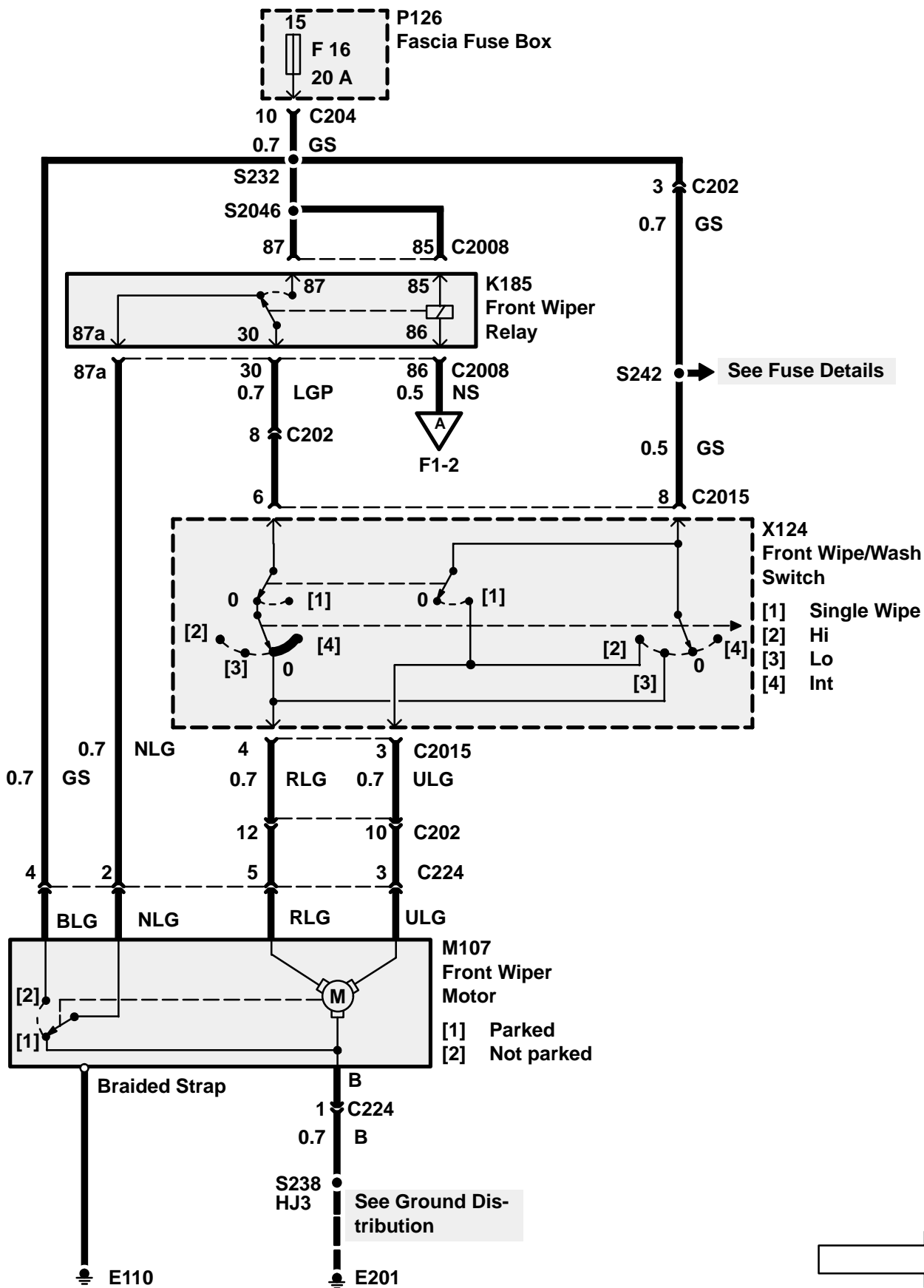

# F1 ETM

## DISCOVERY

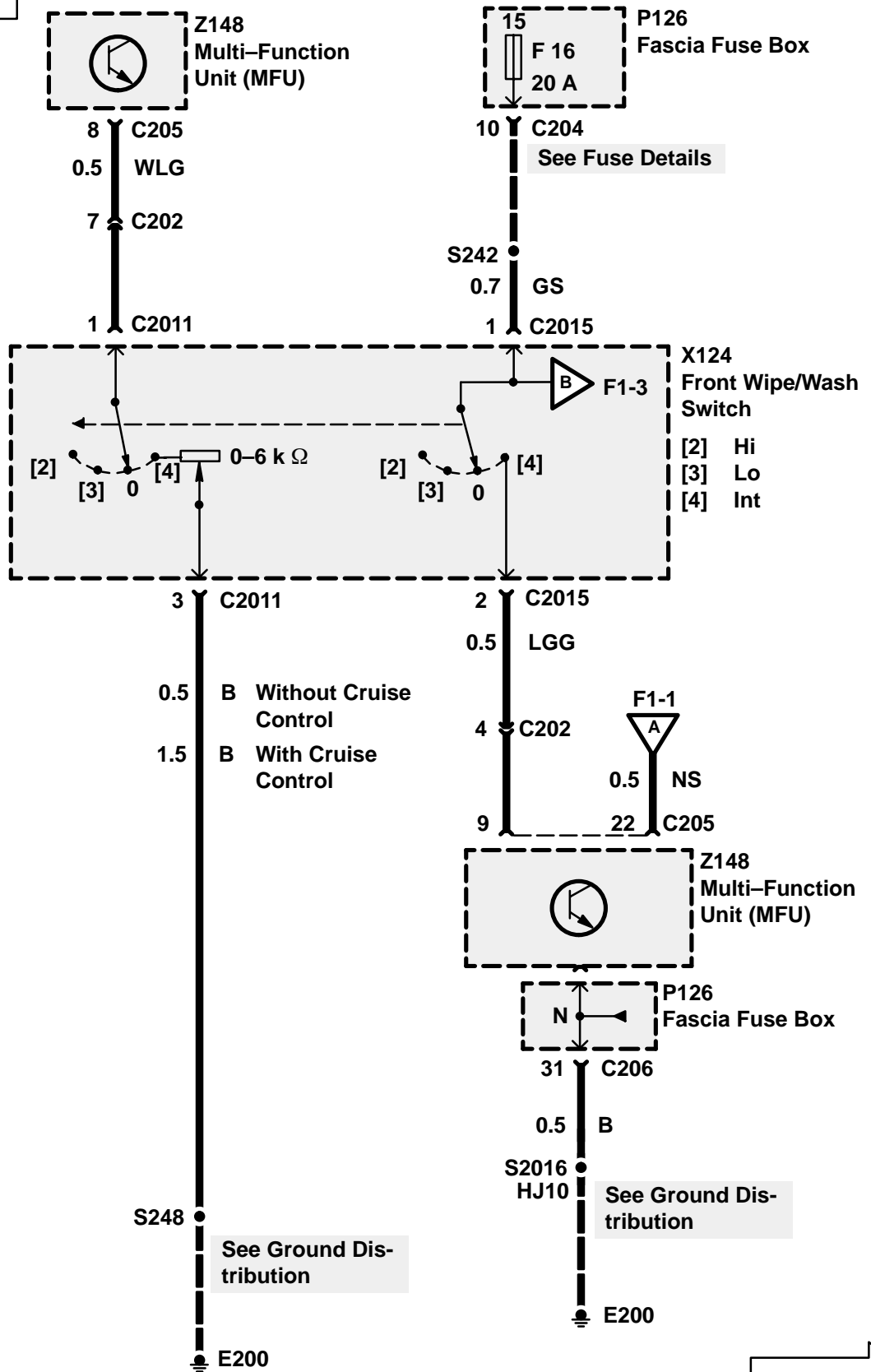

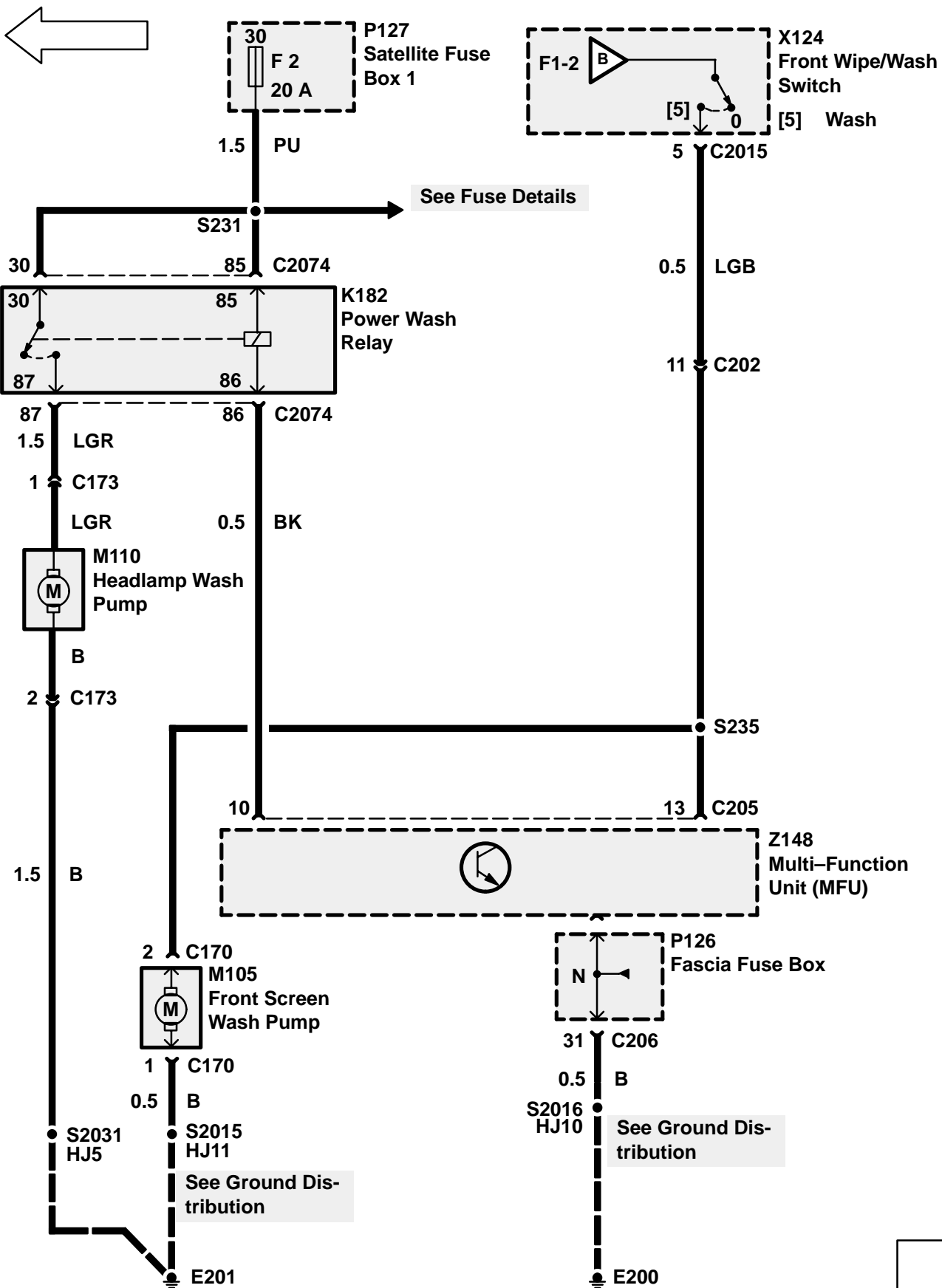



**CIRCUIT OPERATION****Washer**

The Rear Screen Wash Pump (M119) motor is grounded at all times. The motor runs when battery voltage is applied to the motor through the Rear Screen Wash Switch (X222) when the switch is switched to the WASH position.

**Wiper**

When the Rear Wipe Switch (X221) is pulled to the WIPE position, the Multifunction Unit (MFU) (Z148) applies ground to the Rear Wipe Relay (K183). Battery voltage is then applied to the Rear Wiper Motor (M120) from Fuse F18.

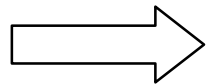
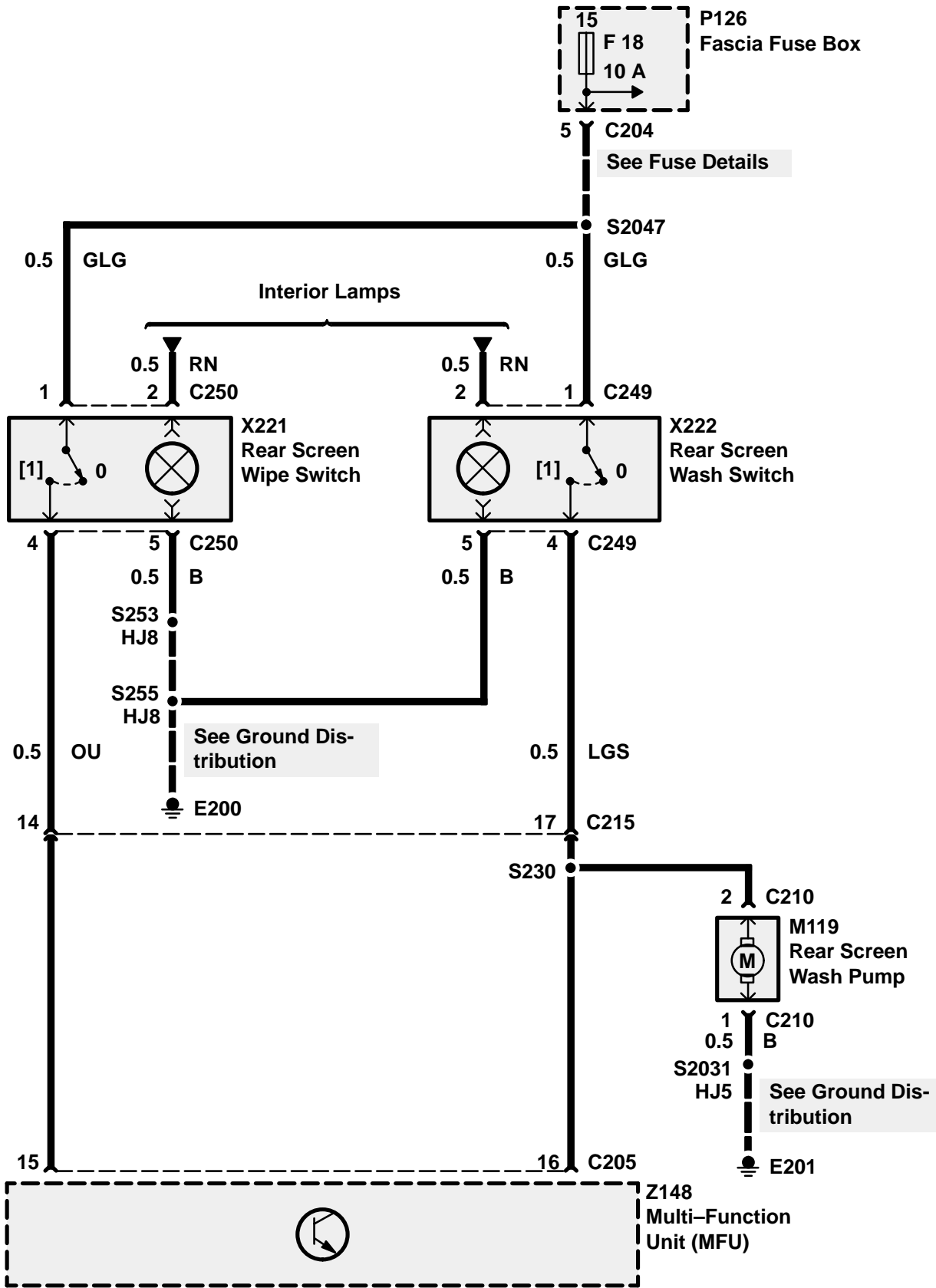

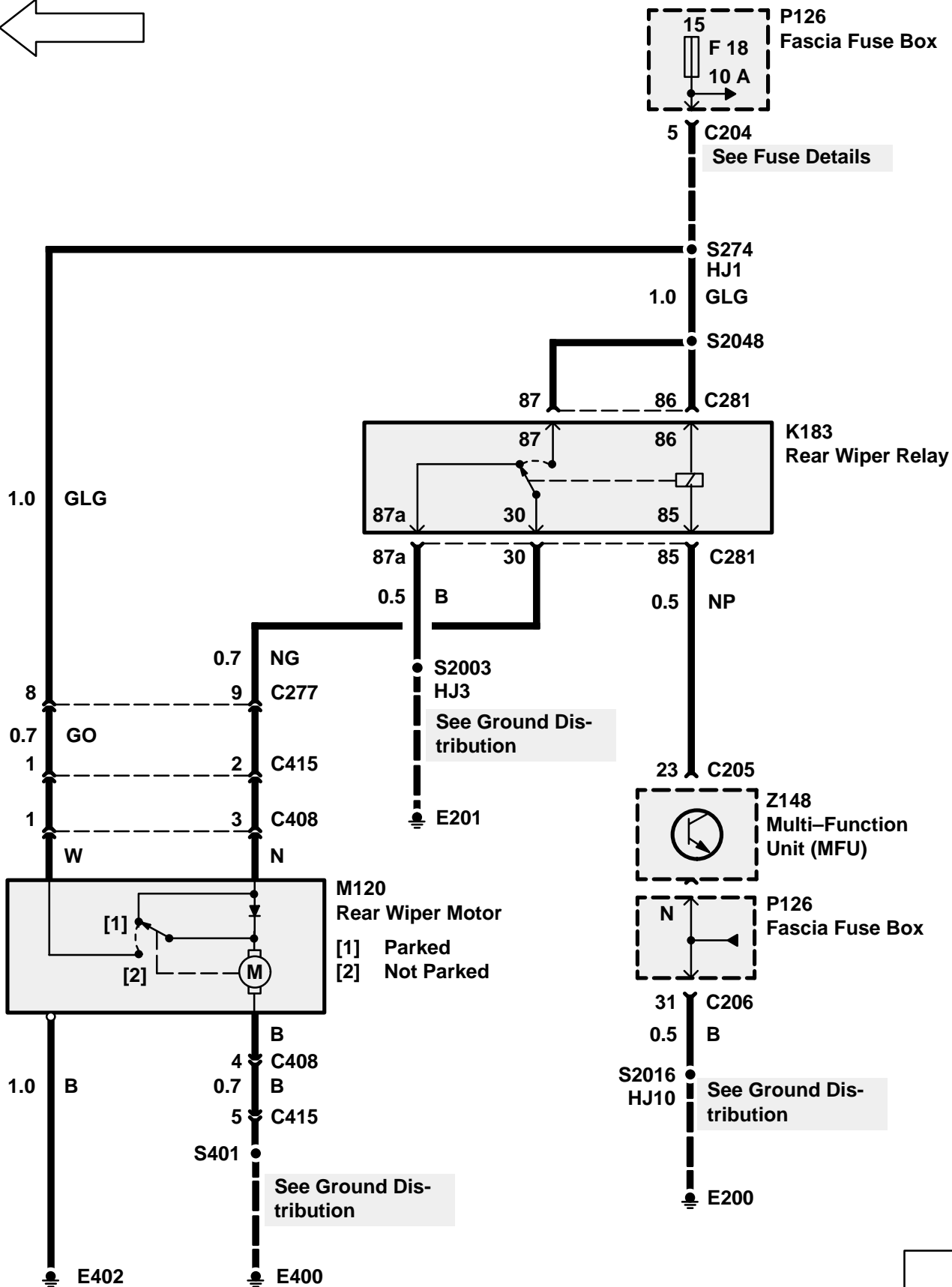
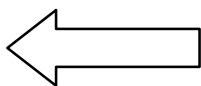

**TROUBLESHOOTING HINTS**

11. If the washer does not operate, check the washer fluid hoses for kinks or blockage.
12. If the wiper does not operate only when washer is requested, check LGS wire and Multifunction Unit (MFU) (Z148).
13. If the wiper operates with tailgate open, check Tailgate Switch (X170) and PB wires.
14. If the sunroof operates, see section L4, Sunroof.
15. If the washer runs continuously, replace the Rear Screen Wash Switch (X222).
16. If wiper and washer do not operate, check GLG wire and Fuse F18.
17. If the wiper will not return to it's parked position when the ignition switch is turned off, check sunroof operation within 45 seconds after turning the ignition off. If the sunroof does not operate check Sunroof Load Relay (K138) and Window Lift ECU (Z147), otherwise check Rear Wiper Motor (M120).

**SYSTEM DIAGNOSIS**

1. If the wiper does not operate, do Test A.
2. If the washer does not operate, do Test B.
3. If the wiper runs with Rear Screen Wipe Switch off, do Test C.

Test A

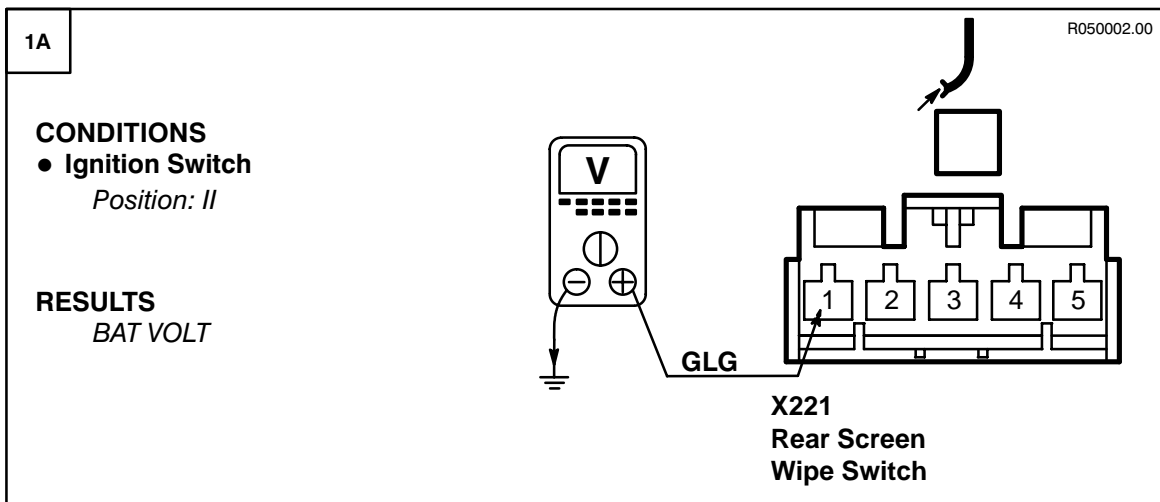

~~OK~~ PROBLEM CAUSE  
- GLG Wire

OK

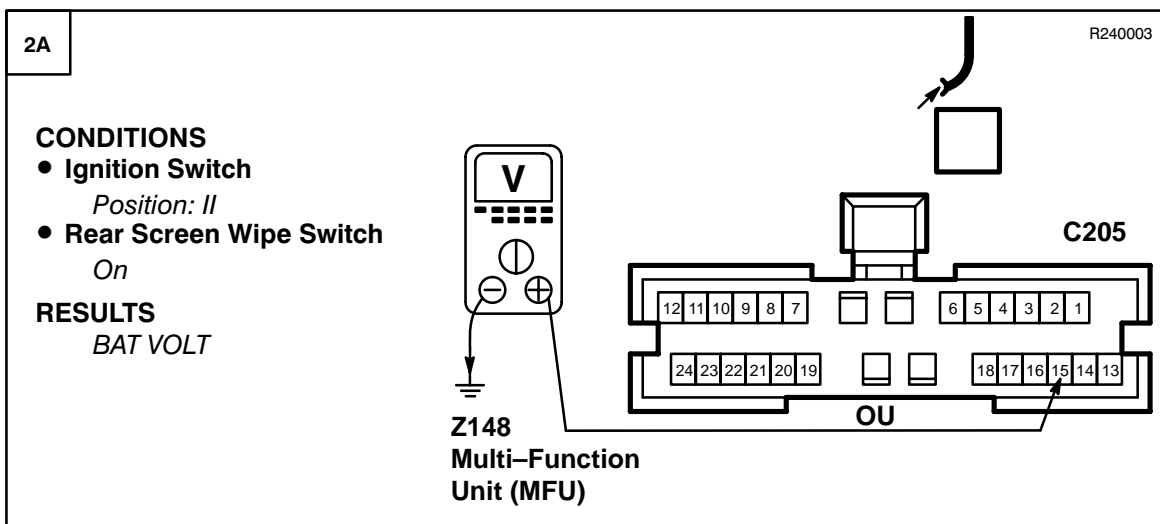
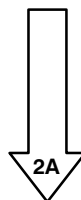

~~OK~~ PROBLEM CAUSE  
- OU Wire  
- Rear Screen  
Wipe Switch

OK

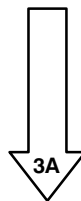

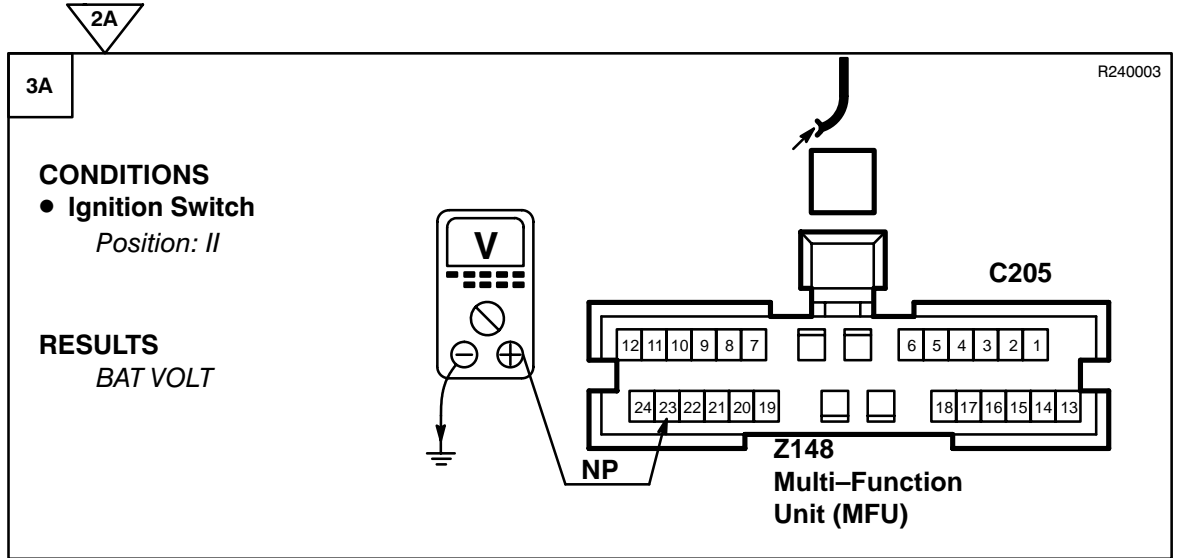

**PROBLEM CAUSE**

- GLG Wire
- NP Wire
- Rear Wiper Relay

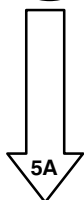
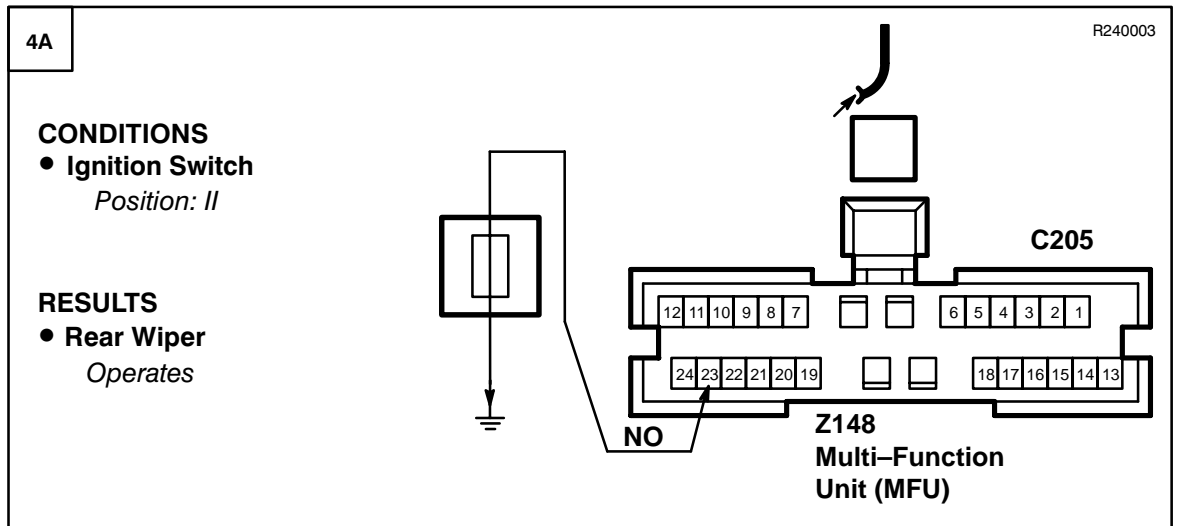
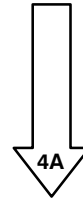

**PROBLEM CAUSE**

- B Wire
- Fascia Fuse Box
- Multi-Function Unit (MFU)

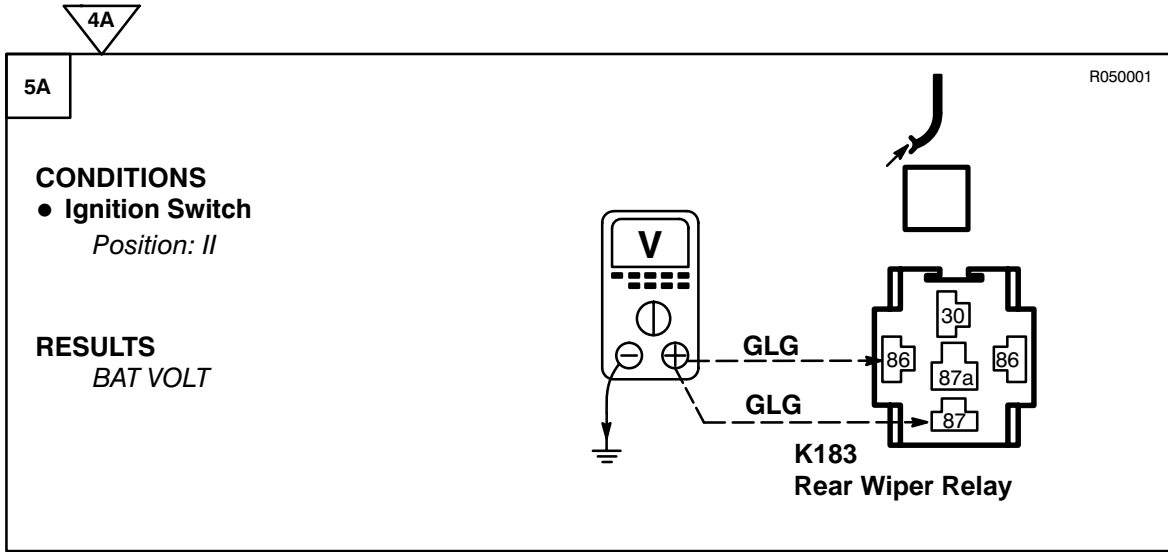

**OK** PROBLEM CAUSE

- GLG Wire
- F18 Fuse

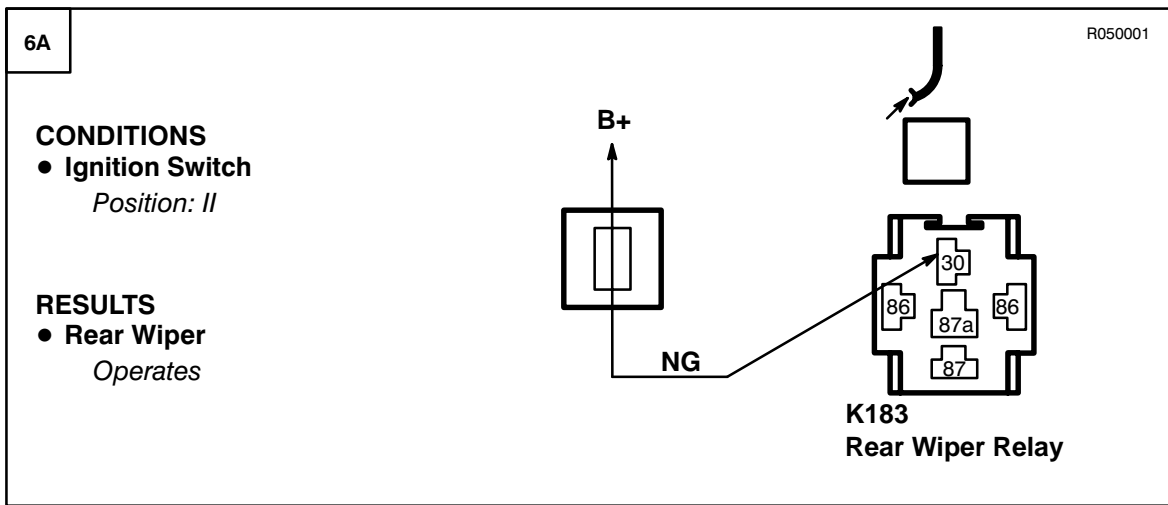
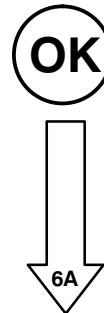

**OK** PROBLEM CAUSE

- NG Wire
- B Wire
- Rear Wiper Motor

**OK** PROBLEM CAUSE

- Rear Wiper Relay

Test B

1B R020037

**CONDITIONS**

- Ignition Switch  
*Position: II*
- Rear Screen Wash Switch  
*WASH*

**RESULTS**  
*BAT VOLT*

M119  
Rear Screen  
Wash Pump



**PROBLEM CAUSE**

- GLG Wire
- LGS Wire
- Rear Screen Wash Switch



2B

2B R020037

**CONDITIONS**

- Ignition Switch  
*Position: 0*

**RESULTS**

- Rear Wiper  
*Less than 2 ohms*

M119  
Rear Screen  
Wash Pump



**PROBLEM CAUSE**

- B Wire



**PROBLEM CAUSE**

- Rear Screen Wash Pump



**Test C**

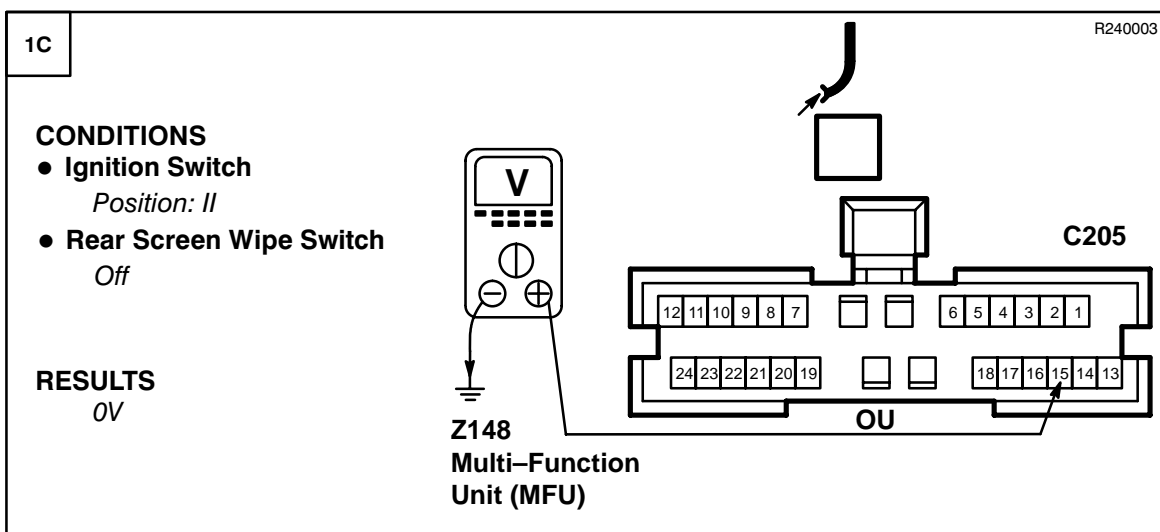

**PROBLEM CAUSE**  
- Rear Screen  
Wipe Switch

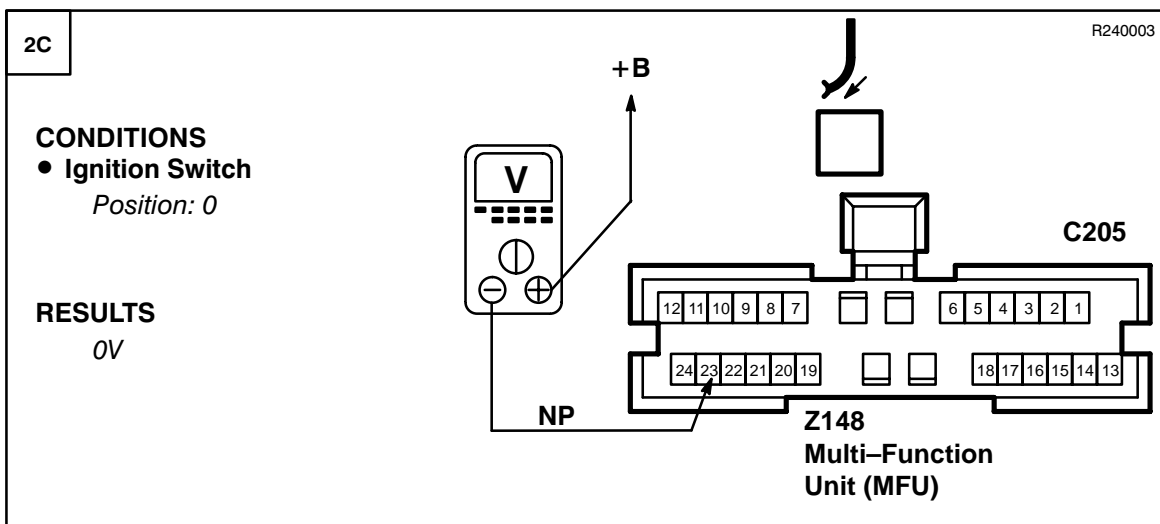
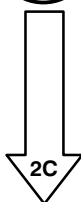

**PROBLEM CAUSE**  
- Multi-Function  
Unit (MFU)



**PROBLEM CAUSE**  
- Rear Wiper Relay

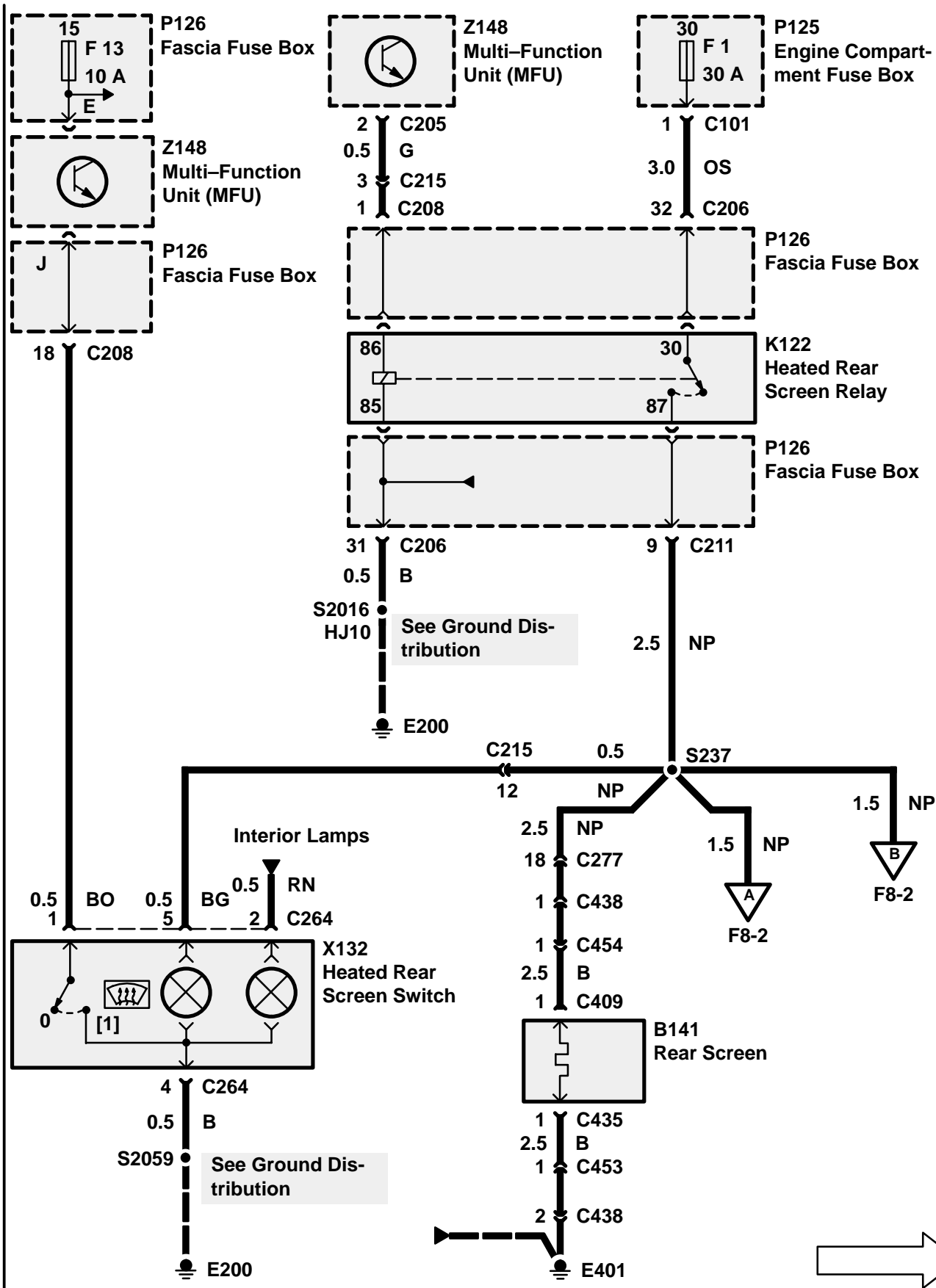

# F8 ETM

## DISCOVERY

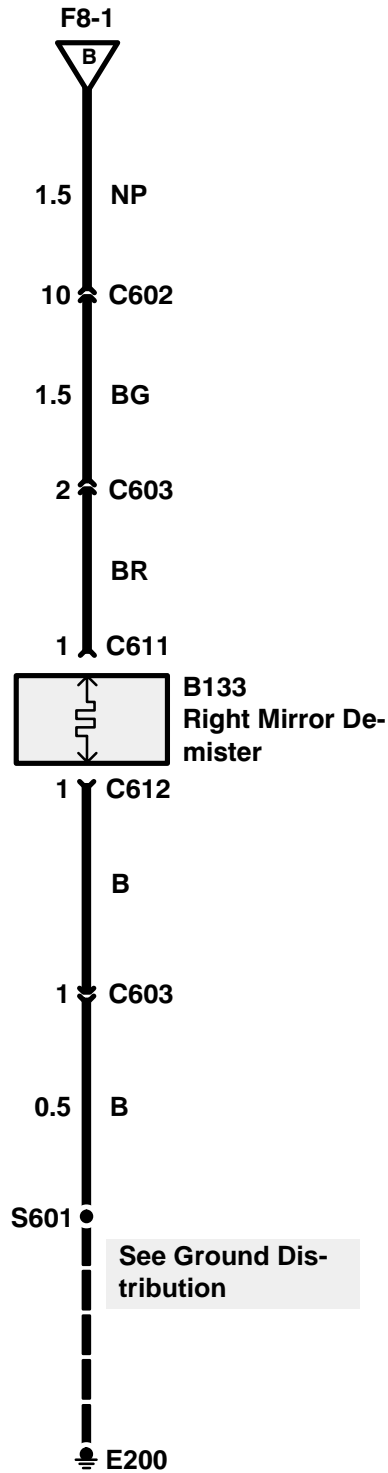
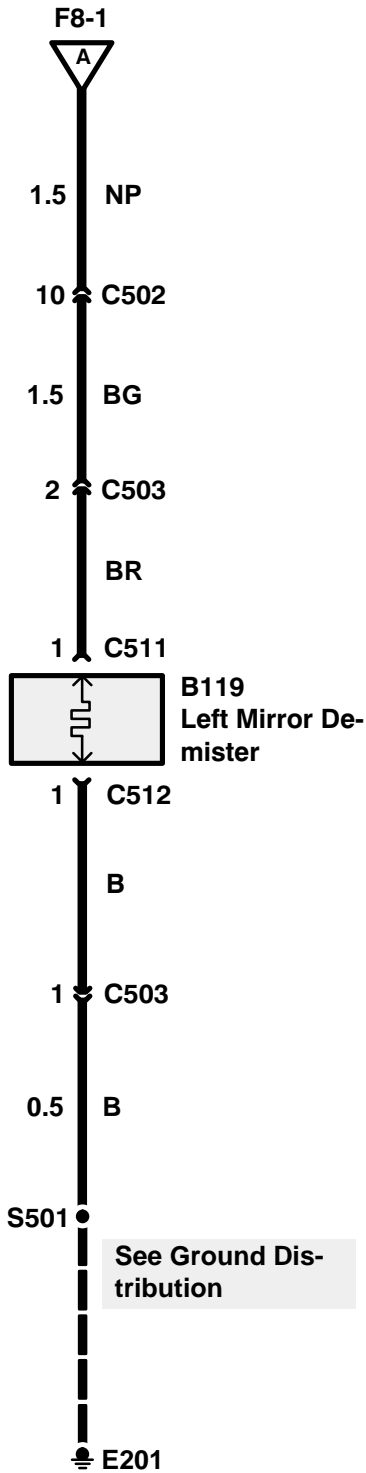
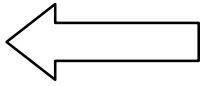

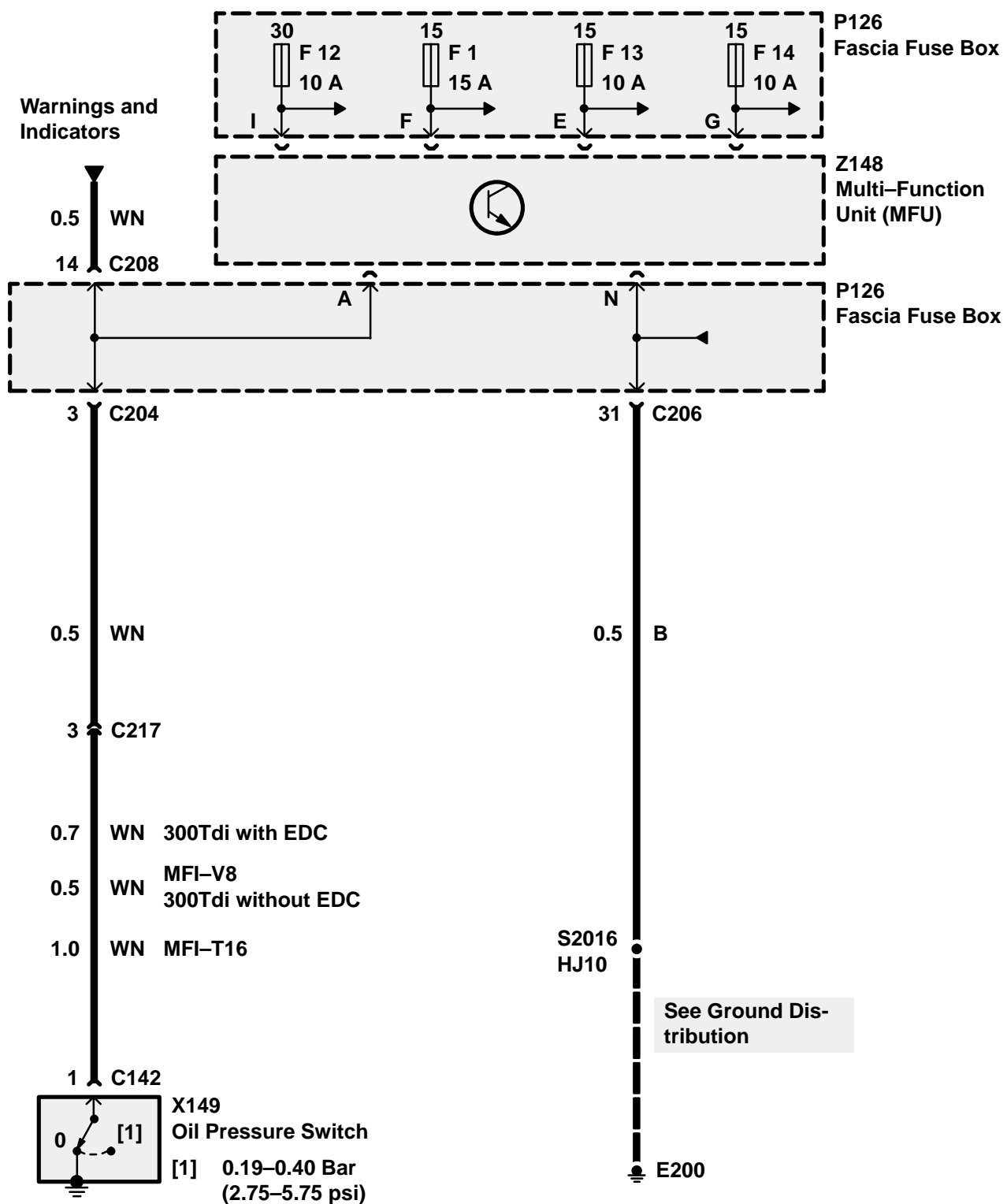



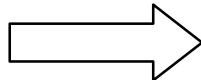
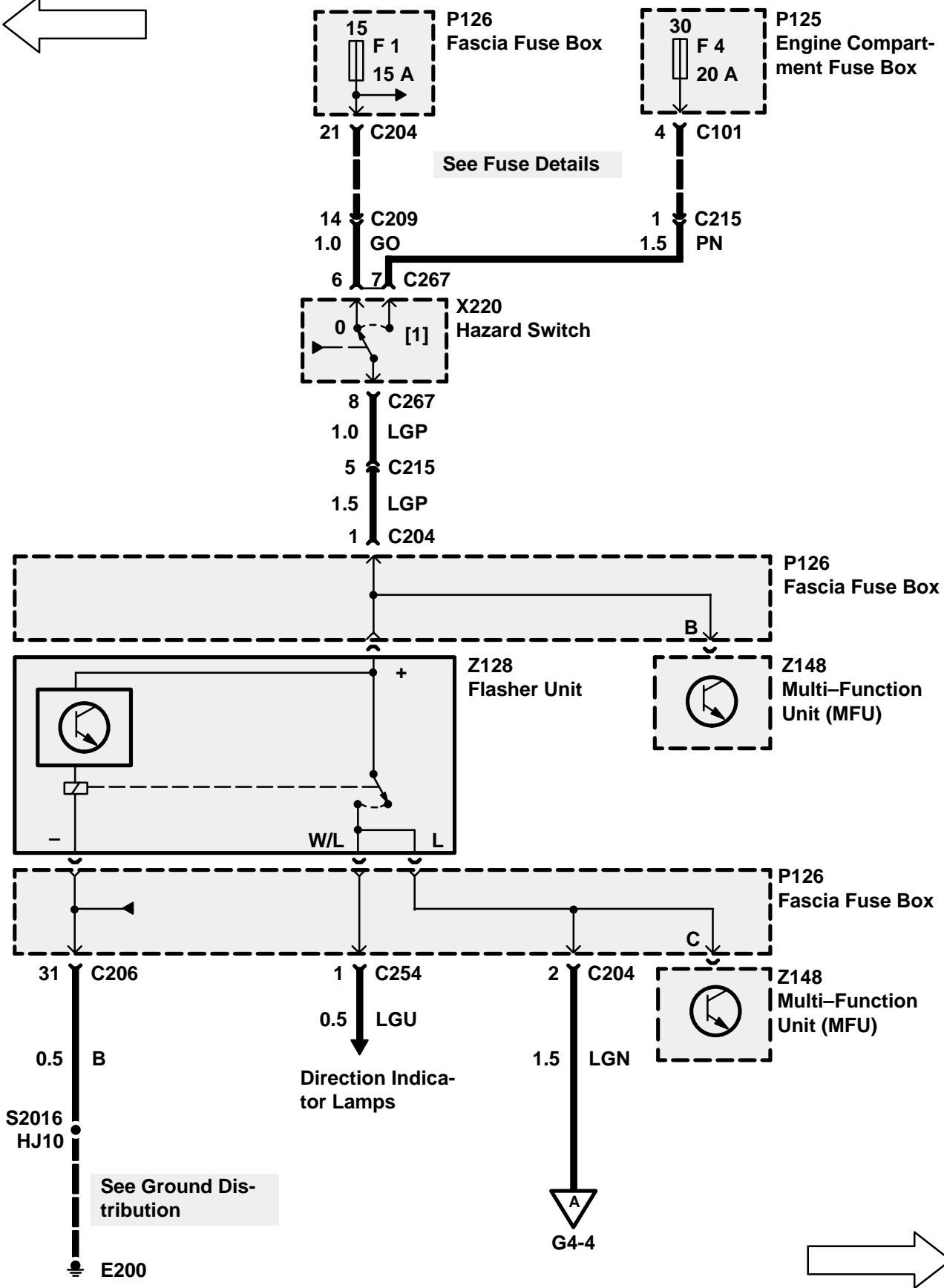
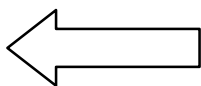







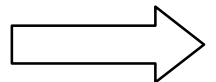
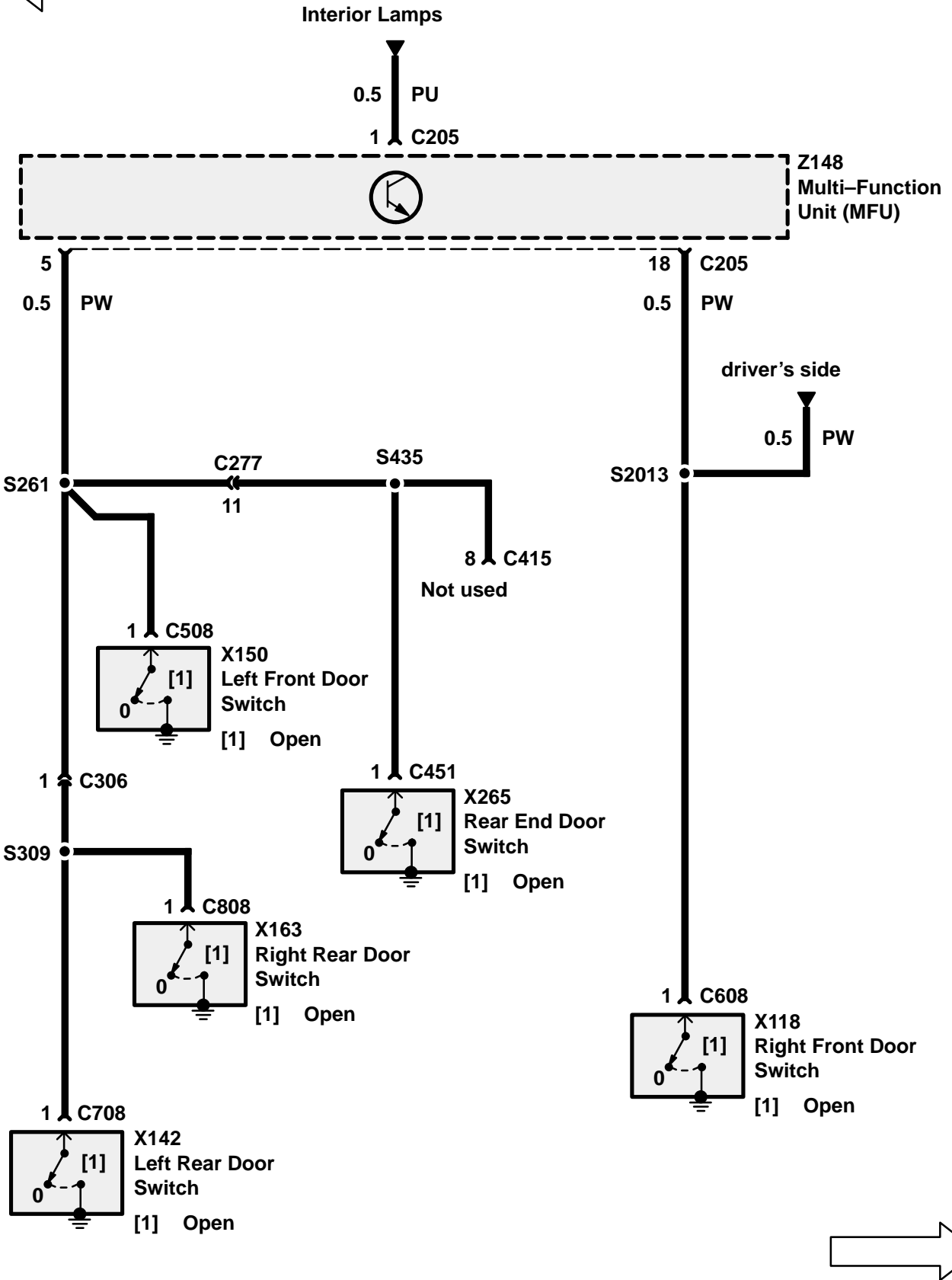
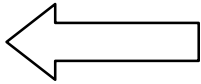

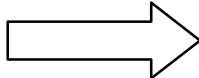
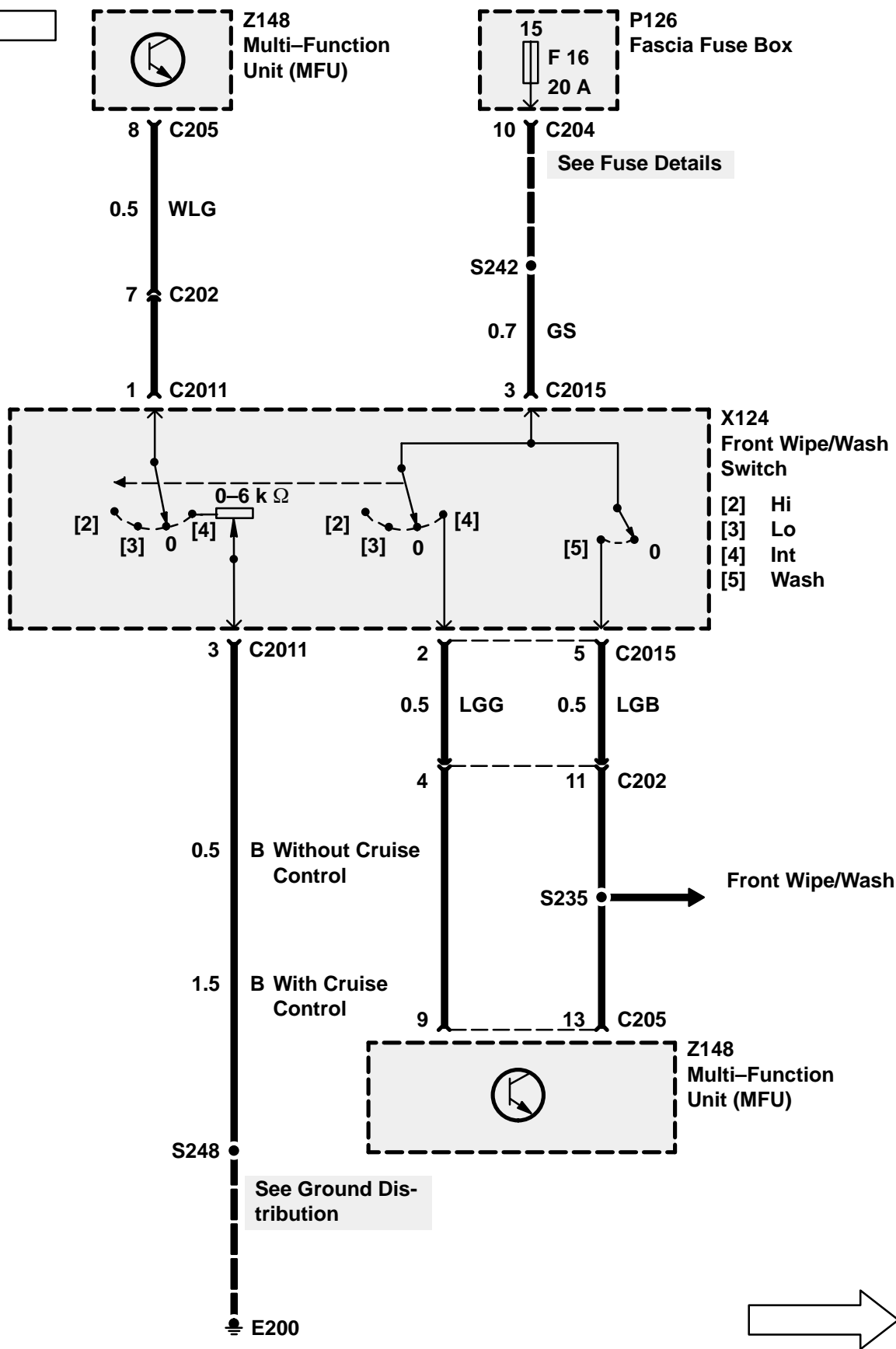
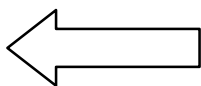

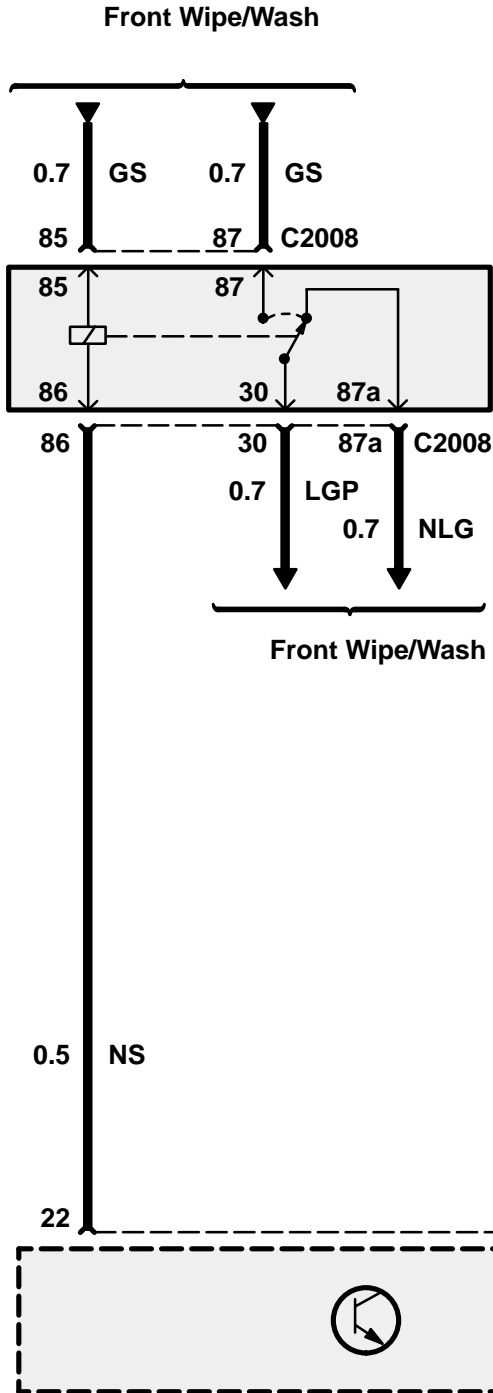
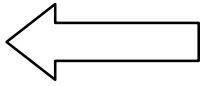

K185 Front Wiper Relay

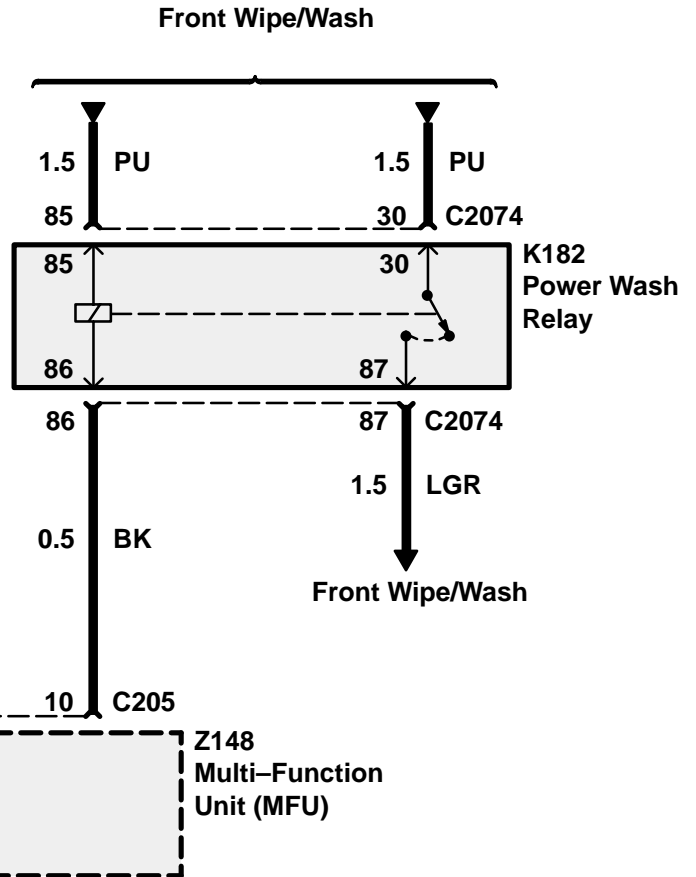

K182 Power Wash Relay

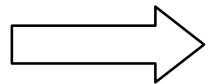

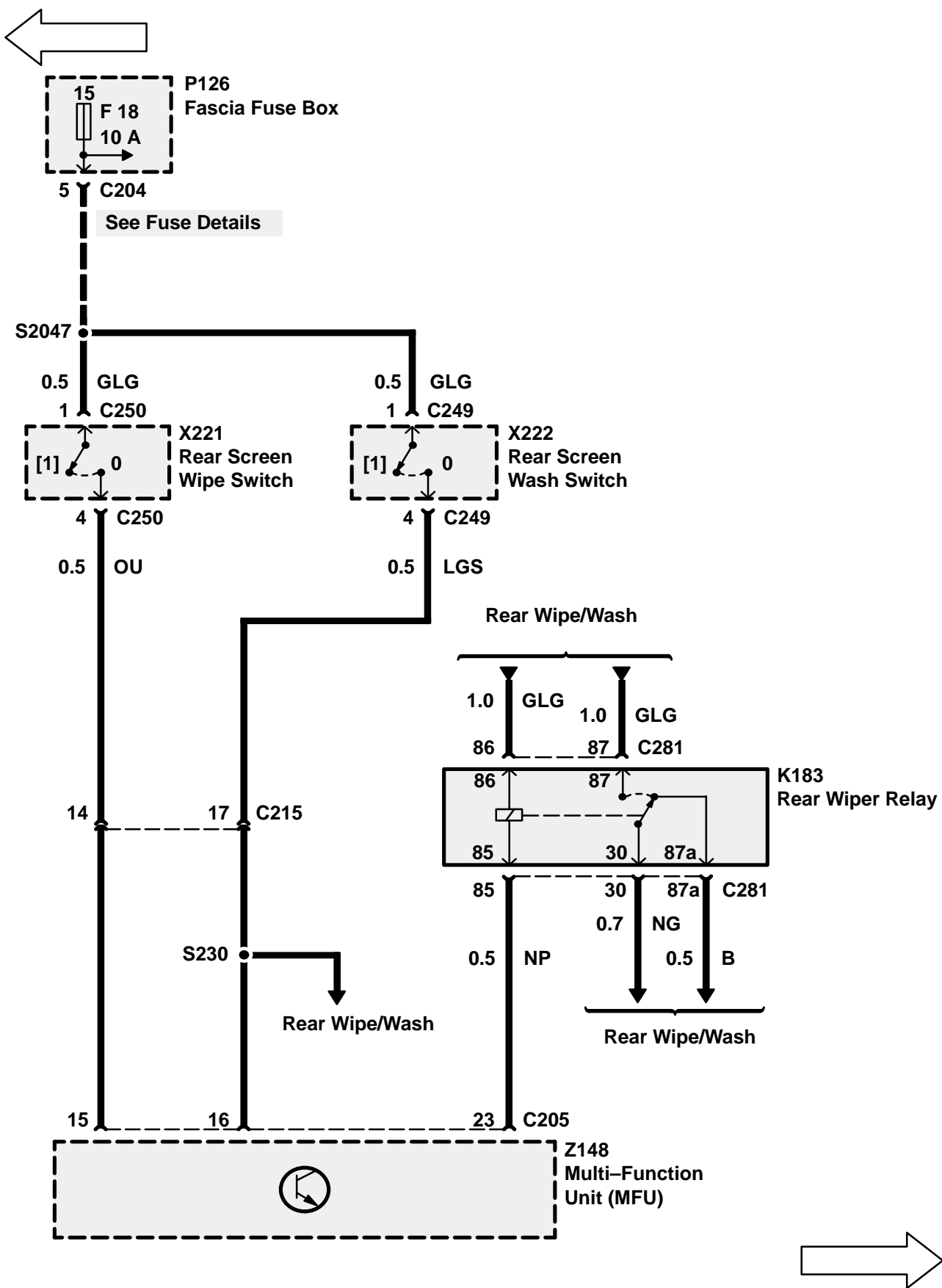

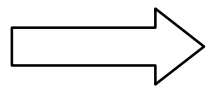
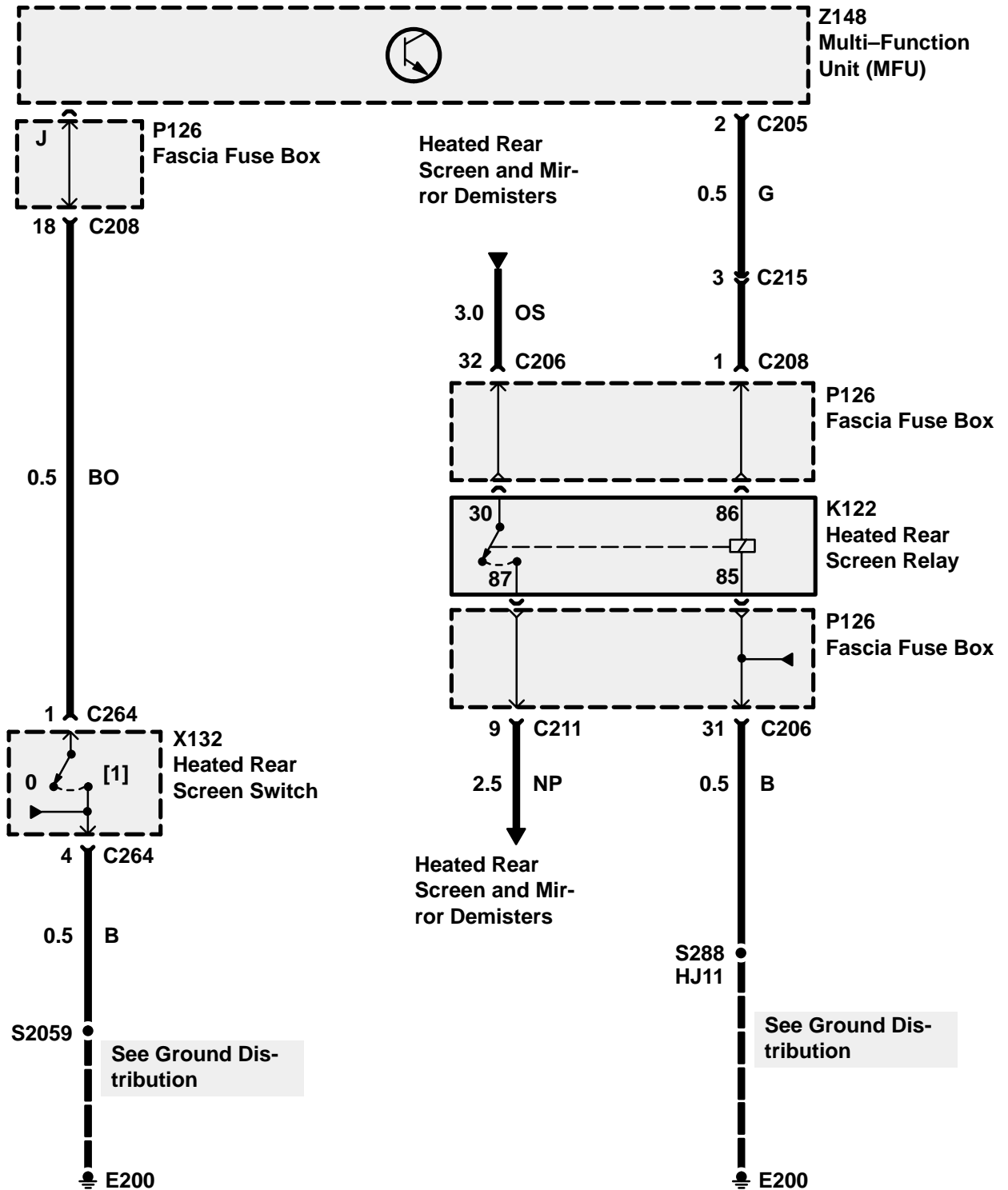
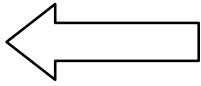

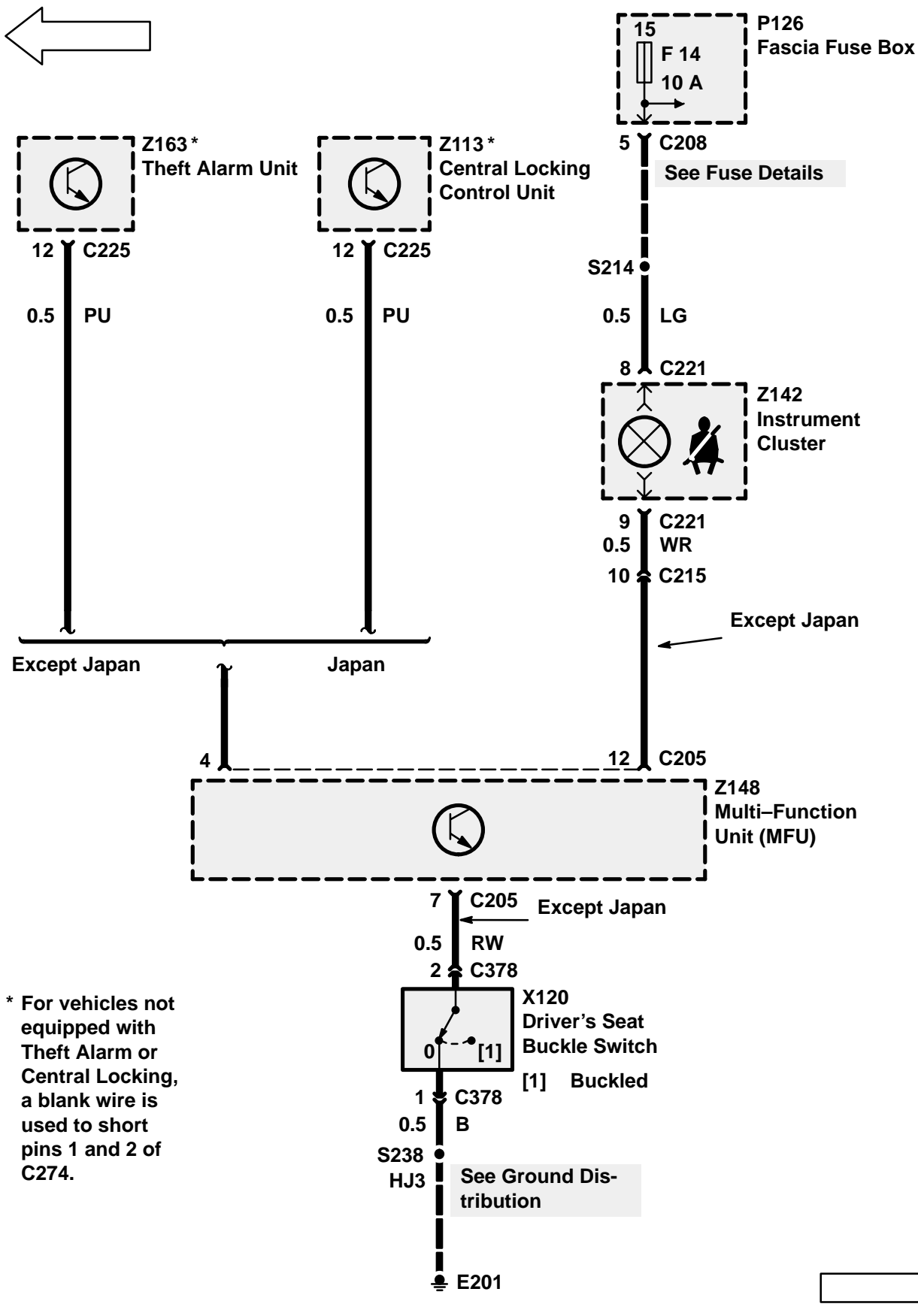

\* For vehicles not equipped with Theft Alarm or Central Locking, a blank wire is used to short pins 1 and 2 of C274.

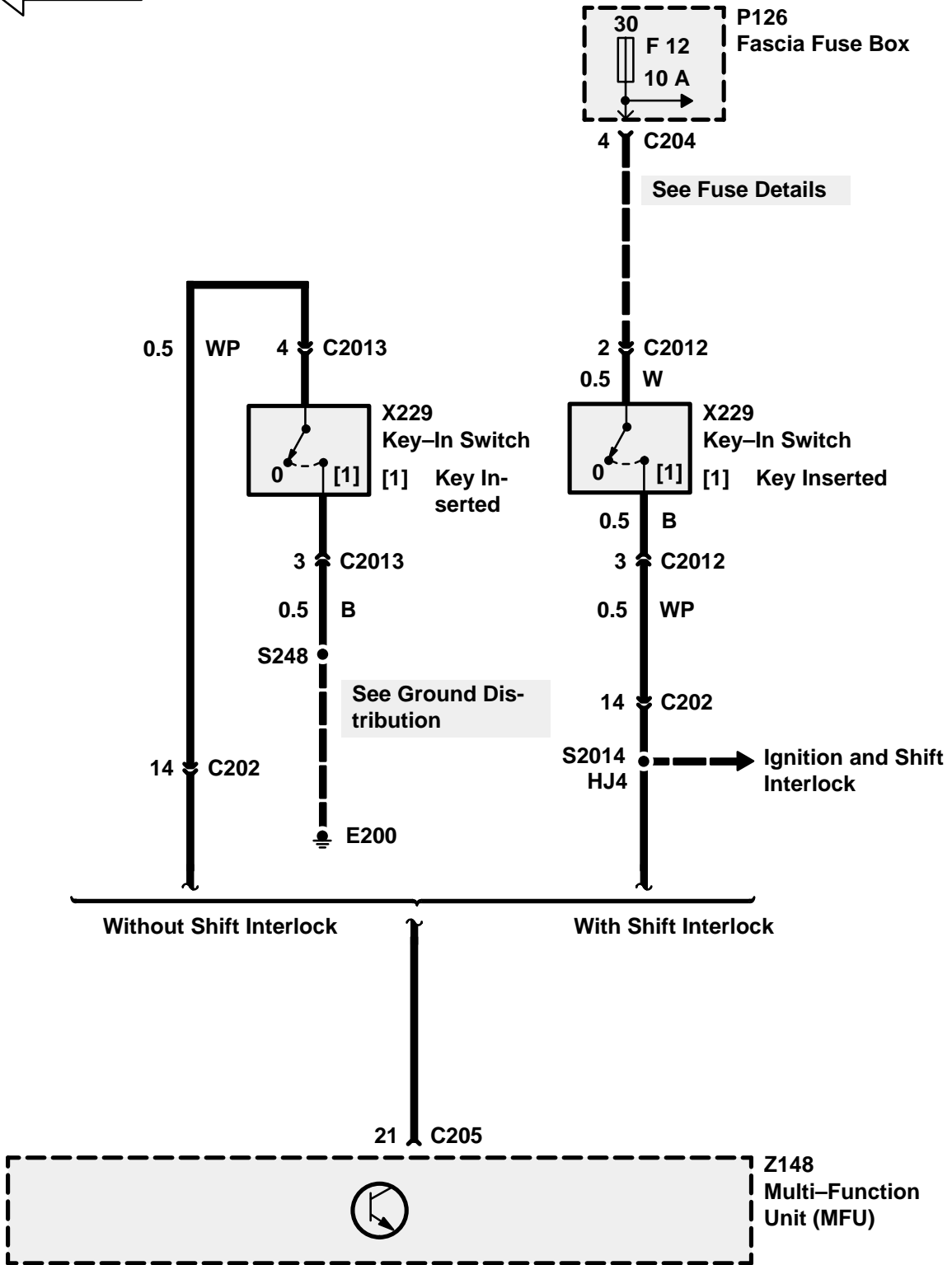

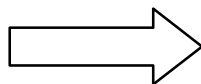
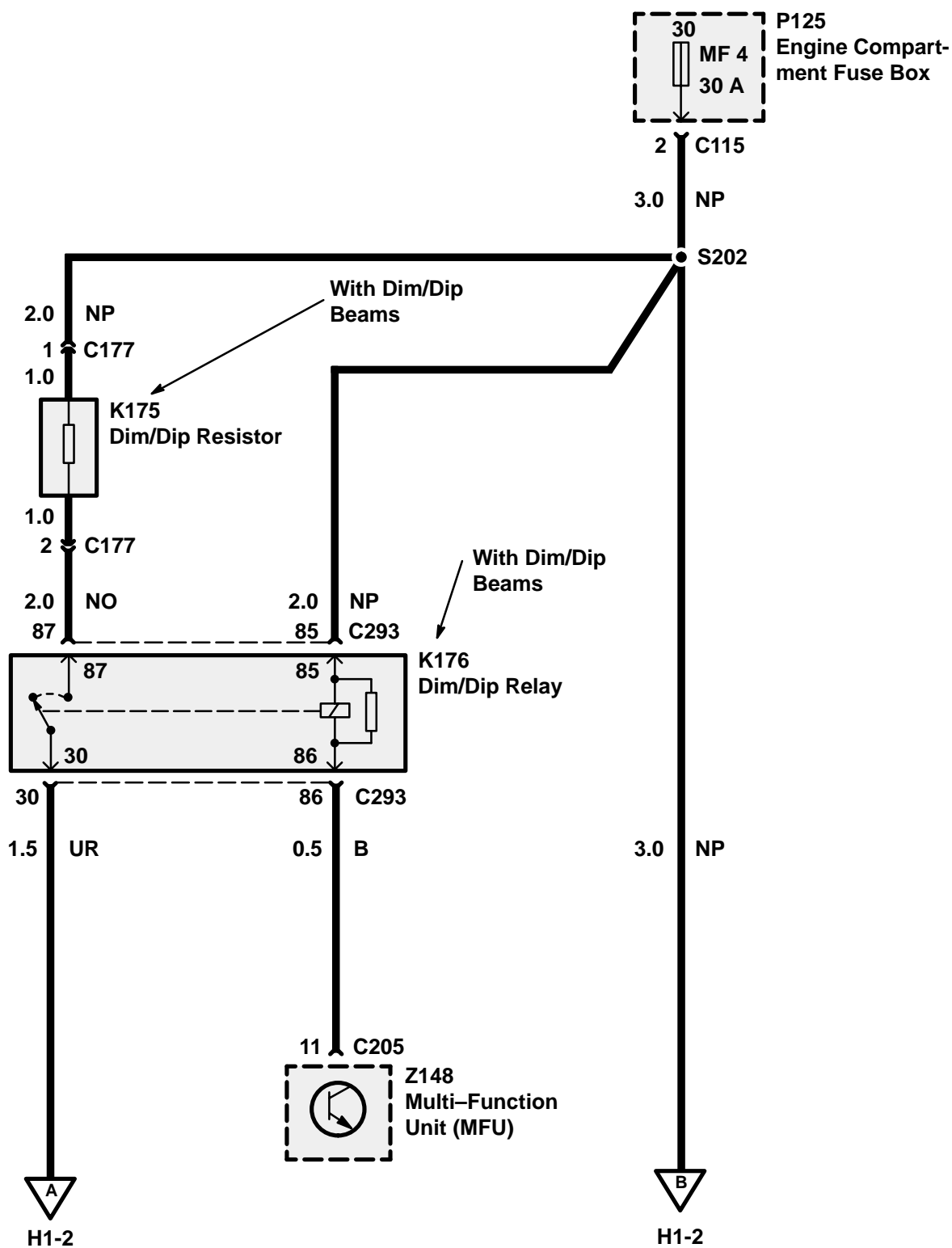



# H1 ETM

## DISCOVERY

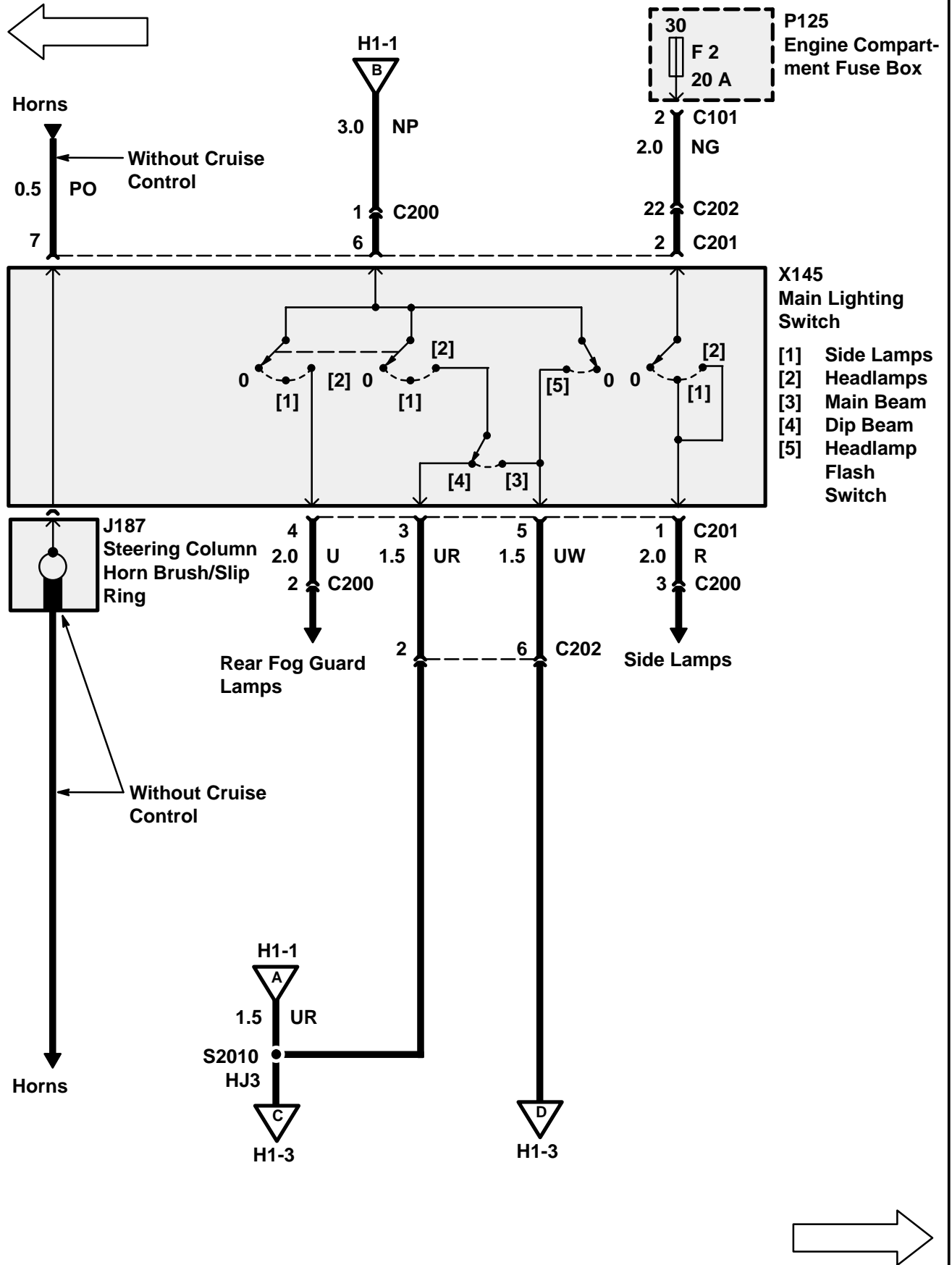

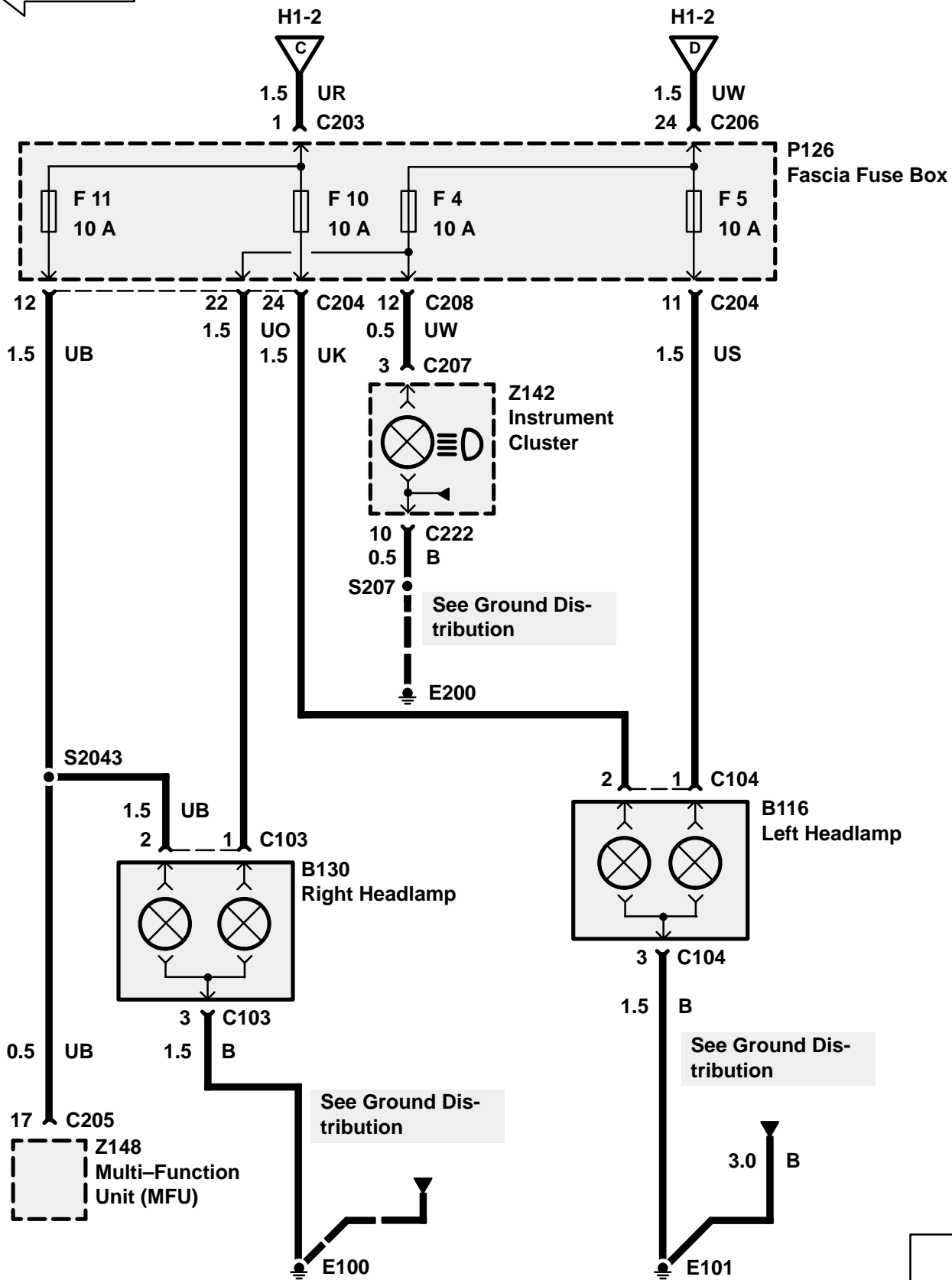
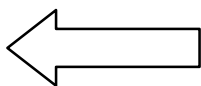



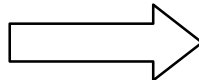
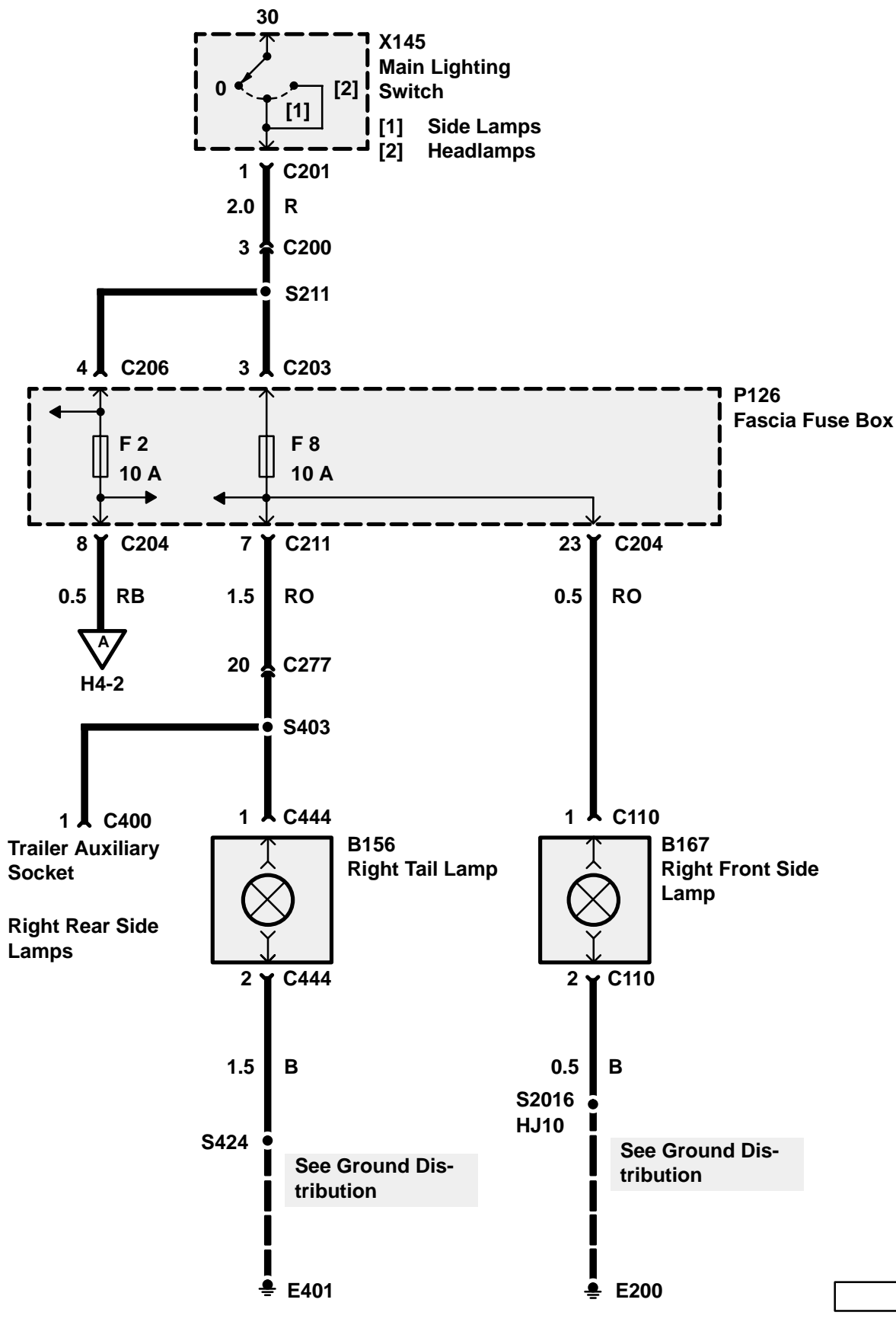

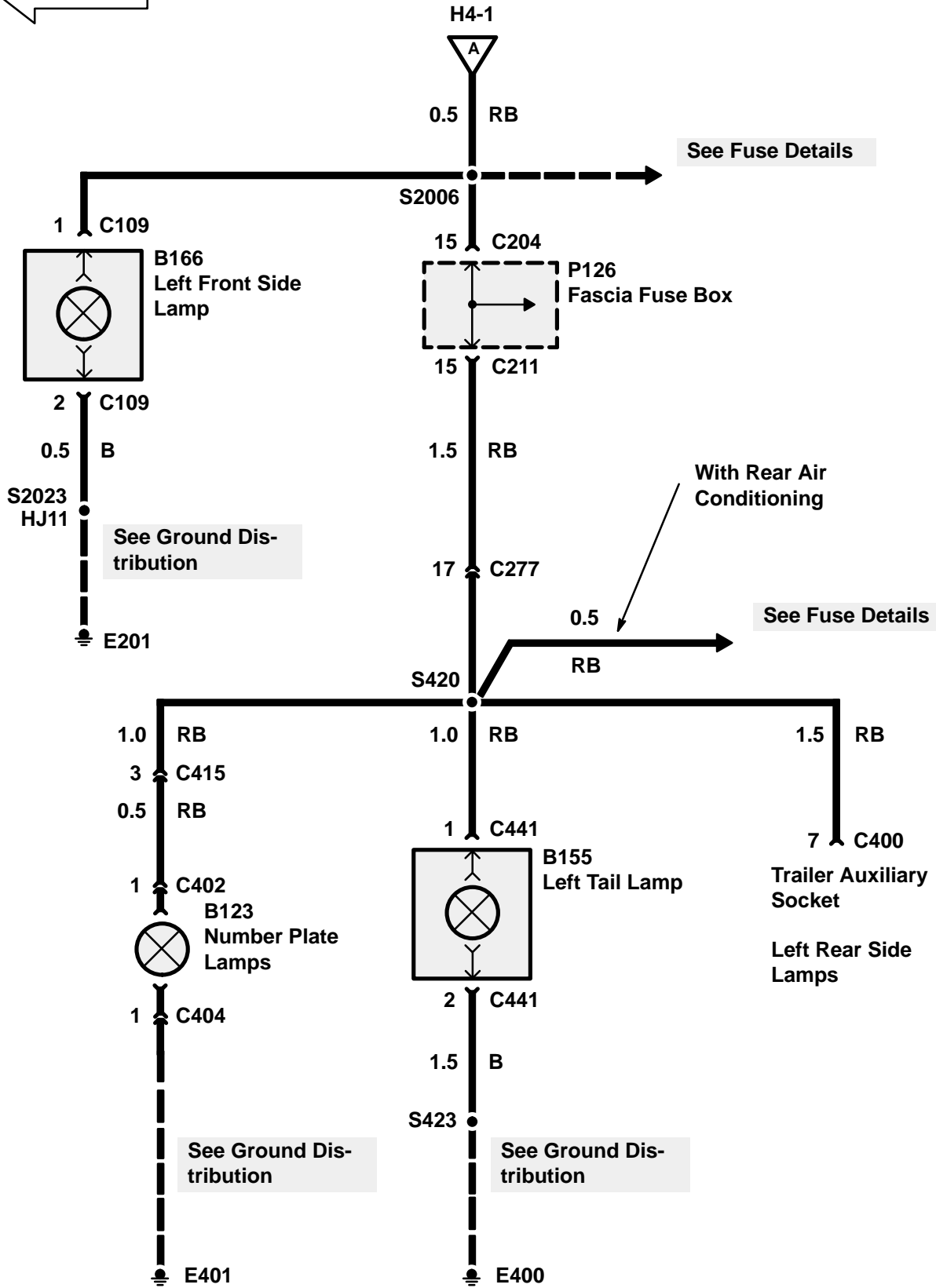
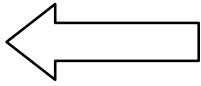

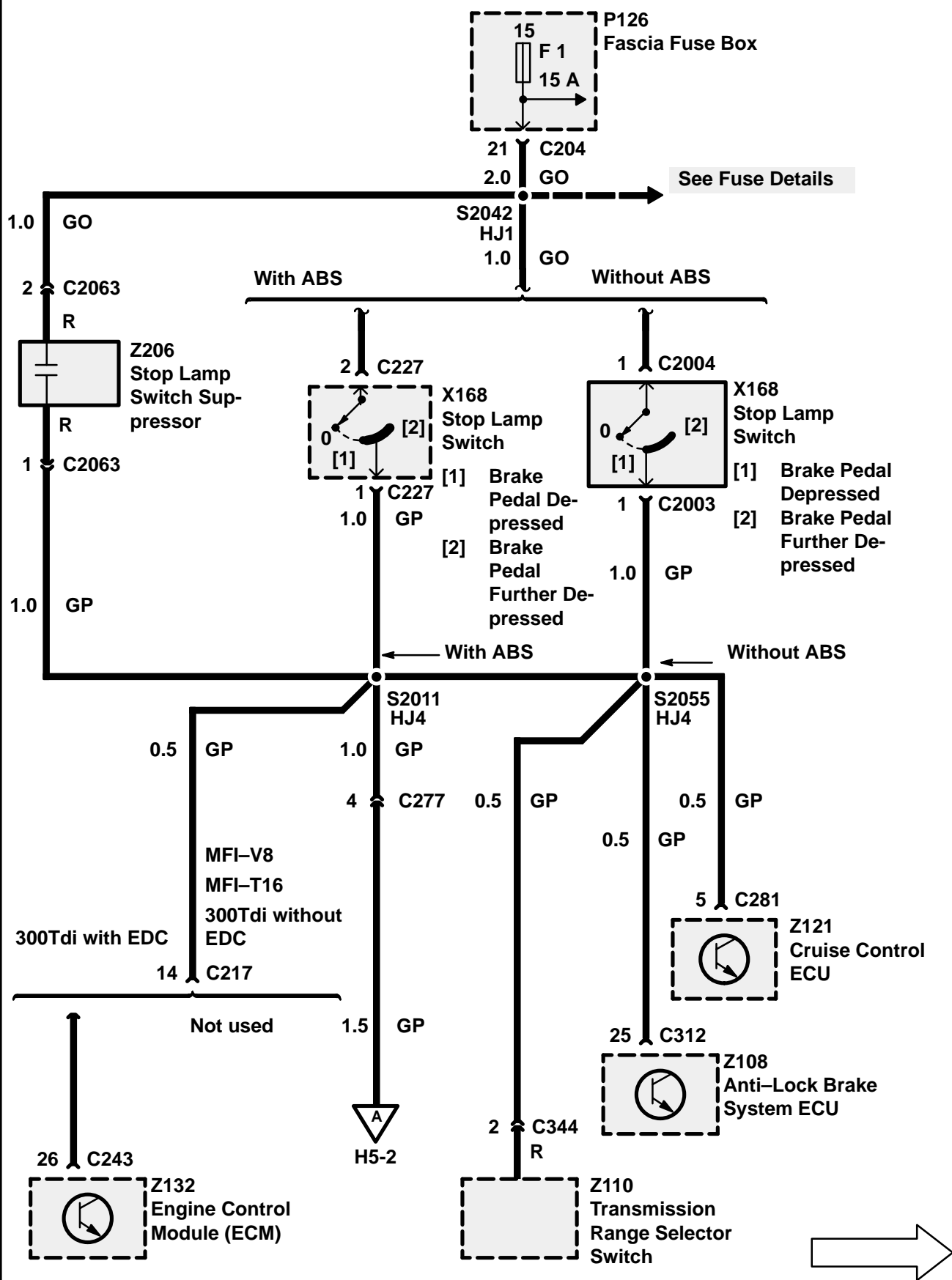

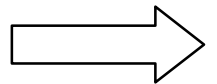
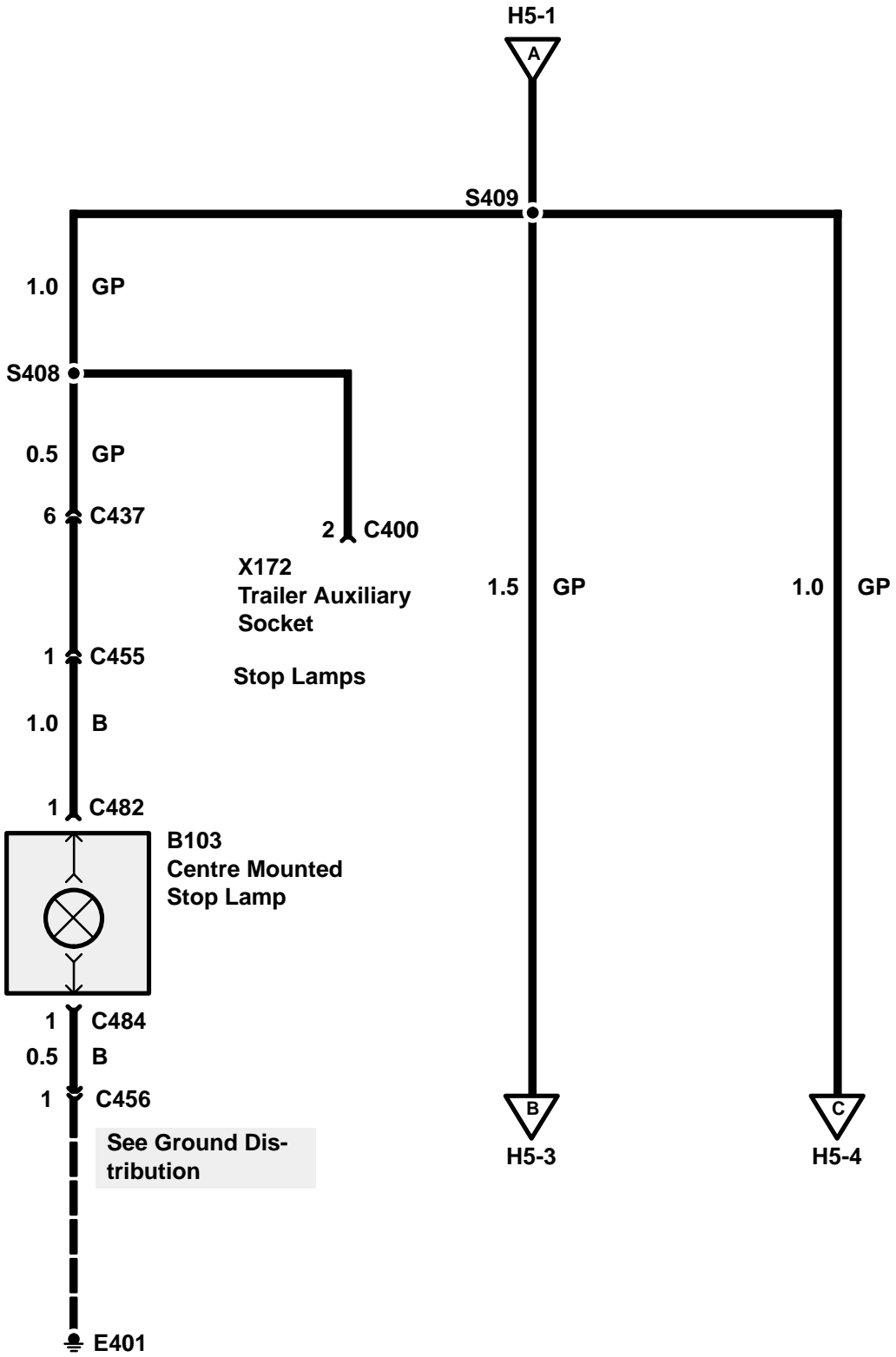
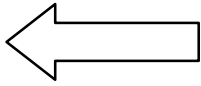

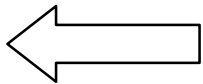

Rear Fog Guard Lamps



Reversing Lamps

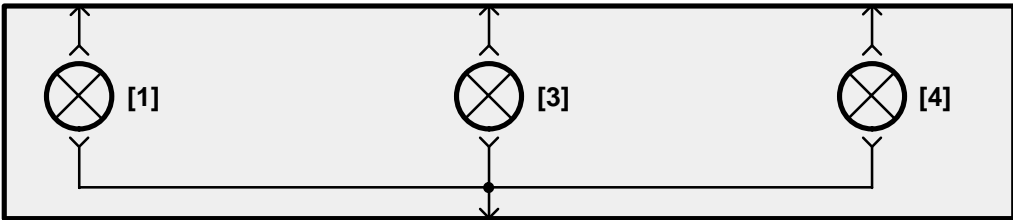
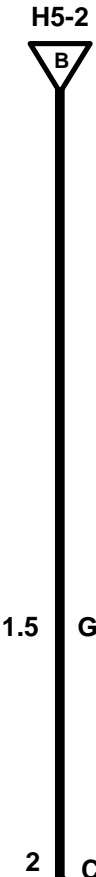

- B121 Left Rear Lamp Assembly
- [1] Rear Fog Lamp
- [3] Reverse Lamp
- [4] Stop Lamp

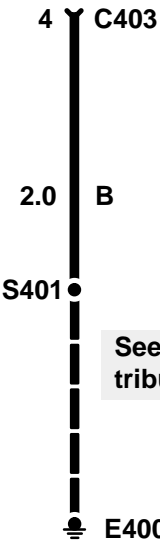

See Ground Distribution

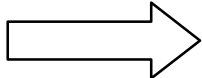



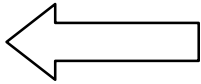

Rear Fog Guard Lamps

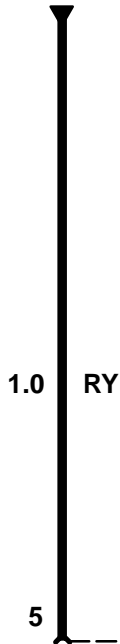

Reversing Lamps

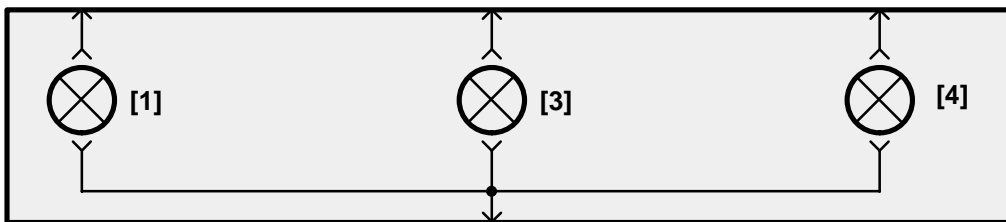
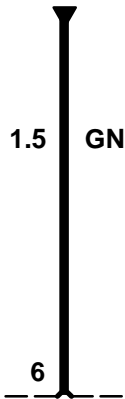

- B136  
Right Rear Lamp  
Assembly**
- [1] Rear Fog Lamp
  - [3] Reverse Lamp
  - [4] Stop Lamp

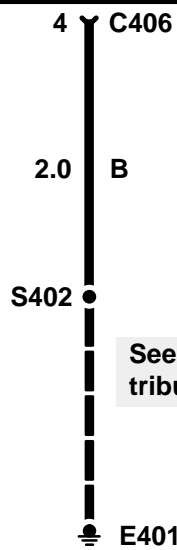

See Ground Dis-tribution



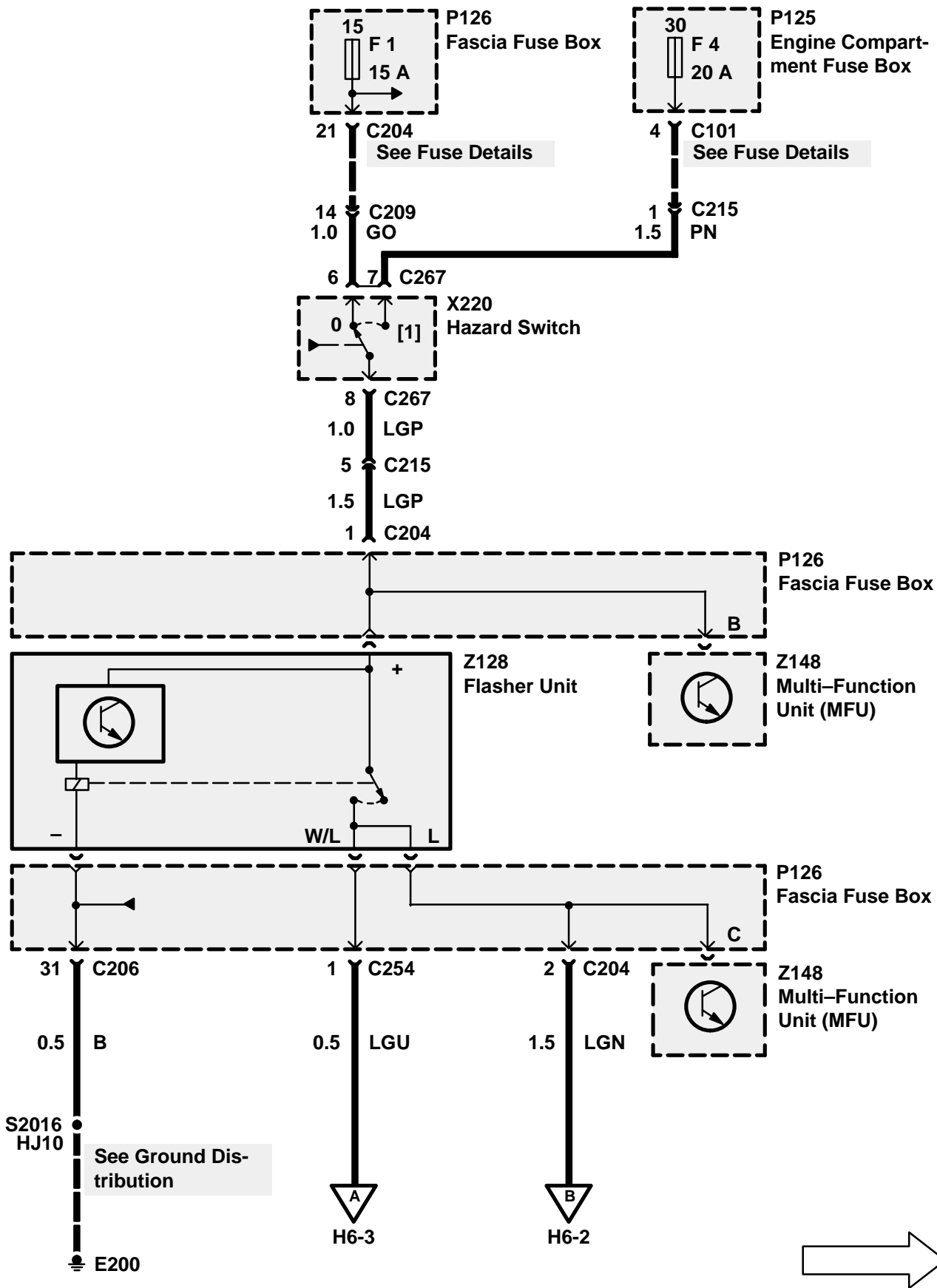

# H6 ETM

## DISCOVERY

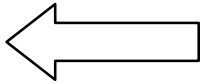

Interior Lamps

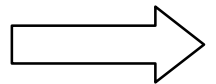
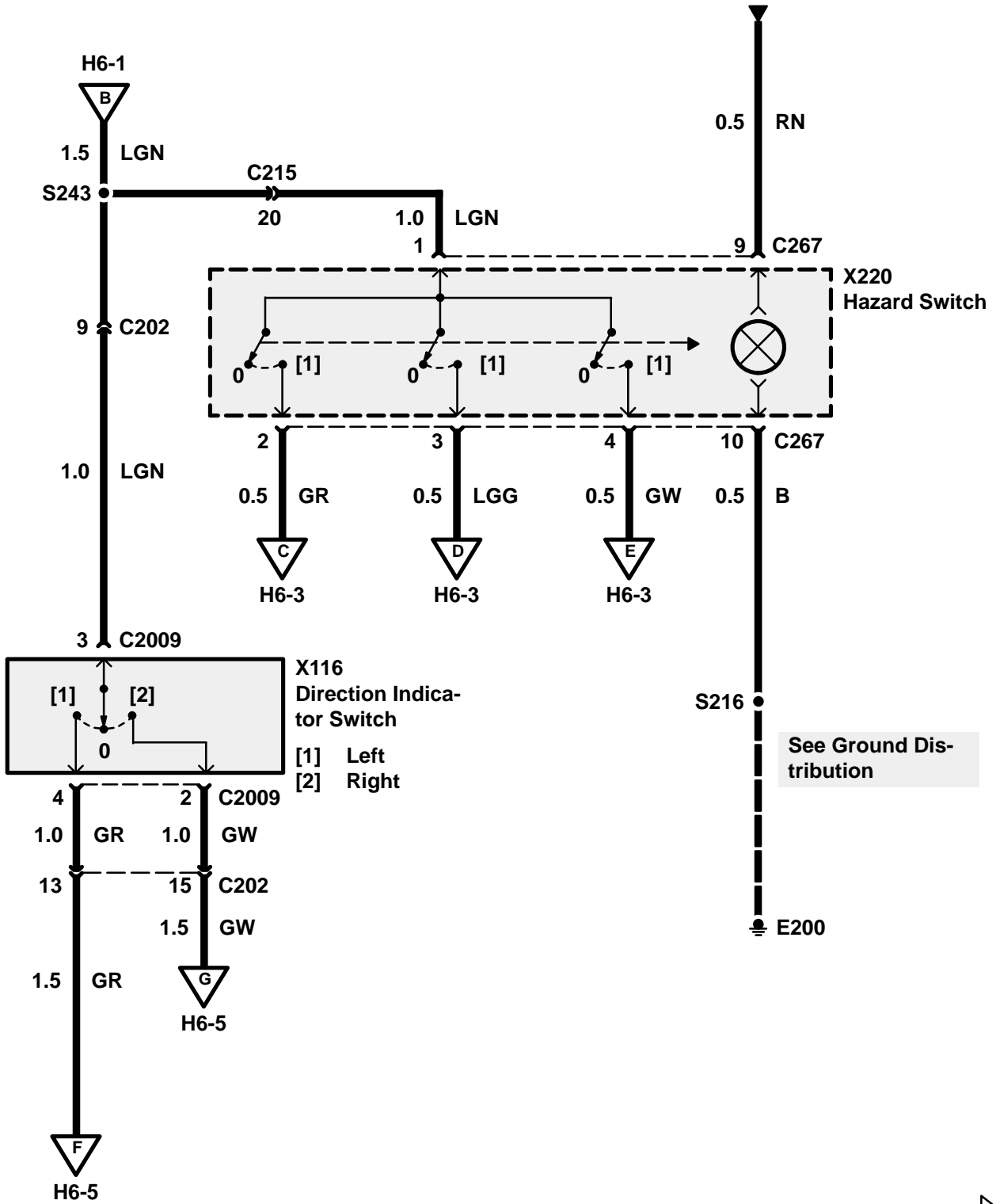

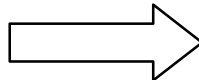
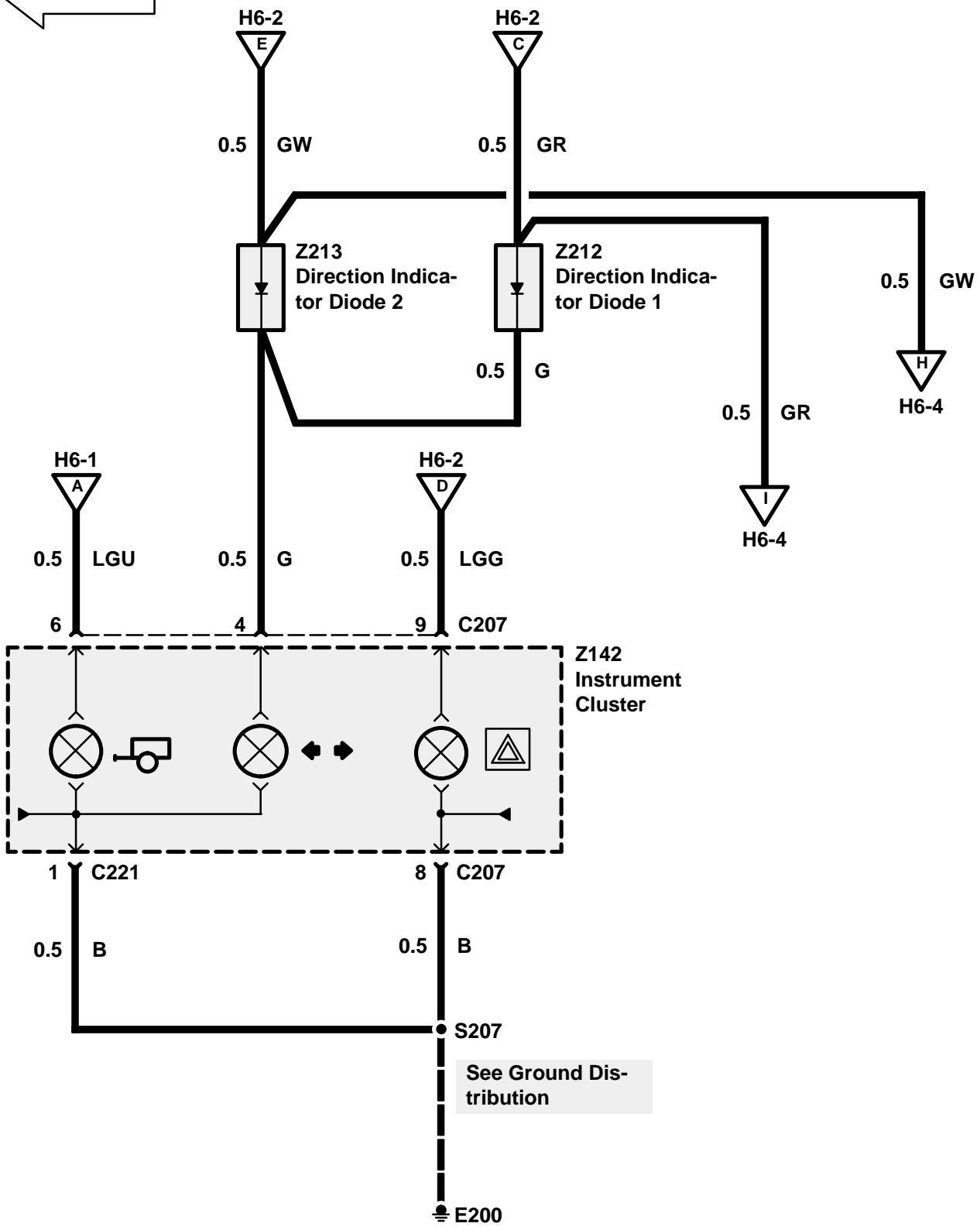
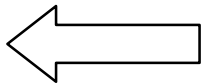

# H6 ETM

## DISCOVERY

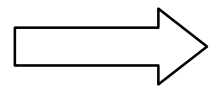
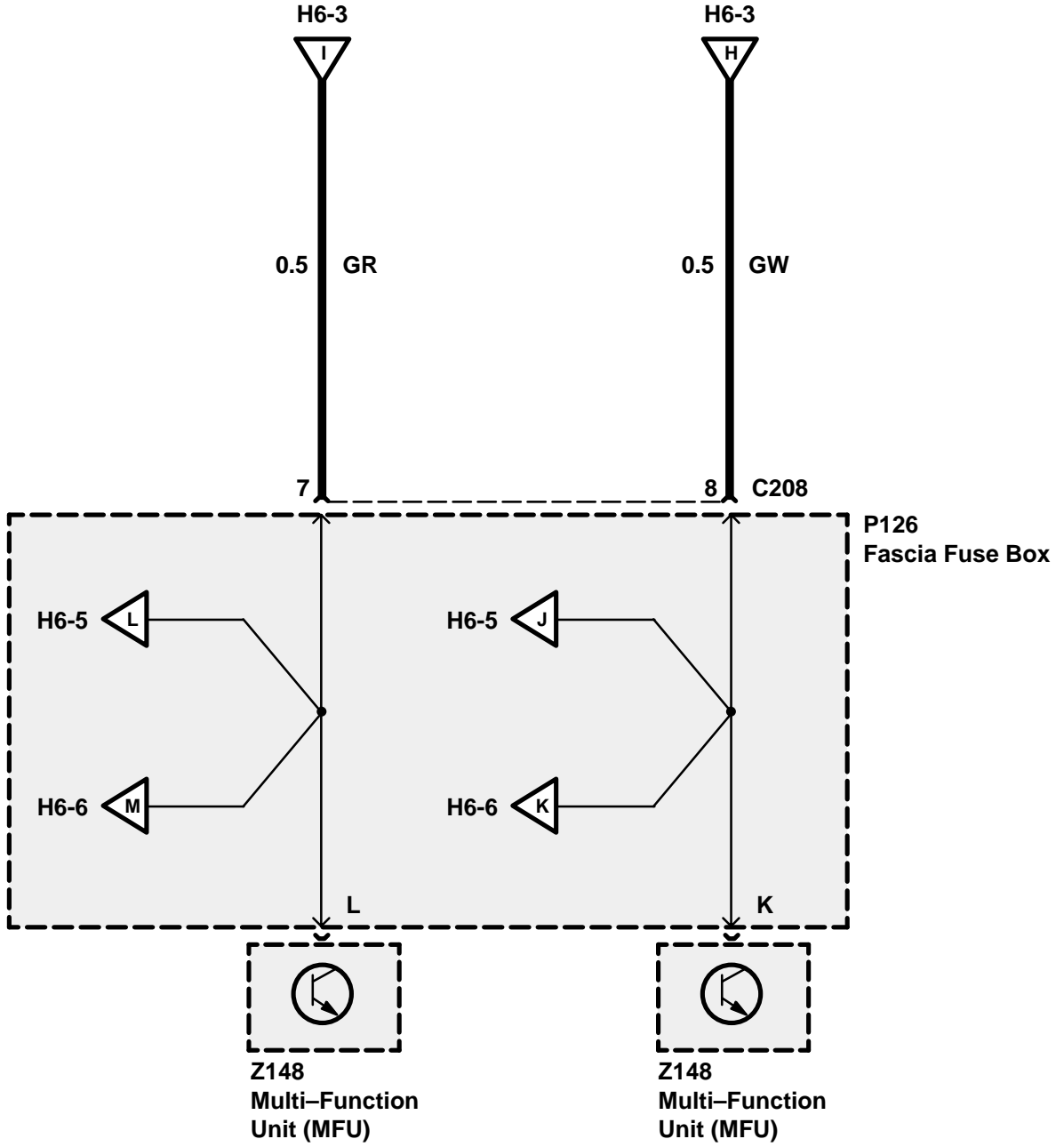
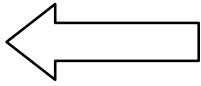

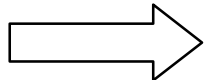
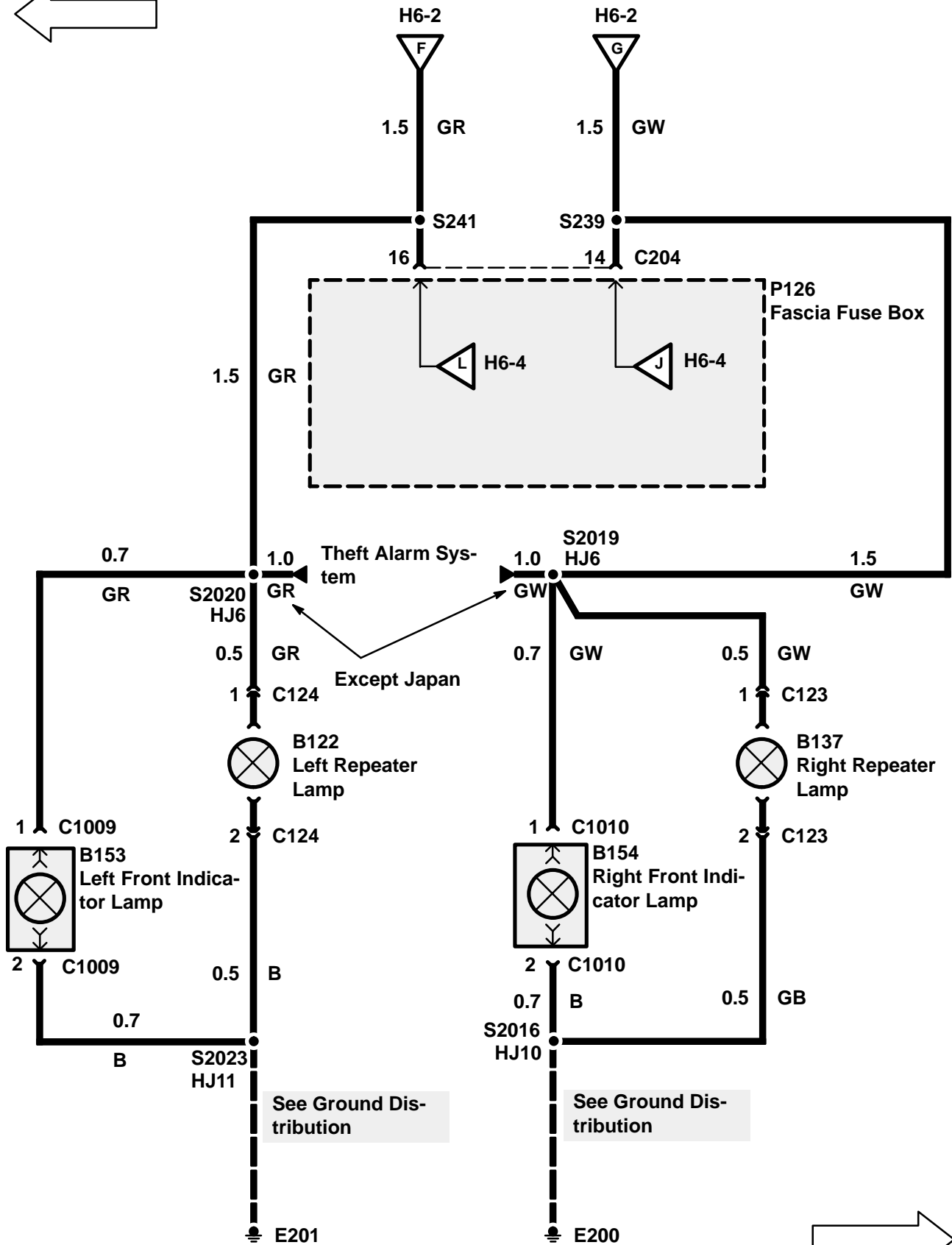
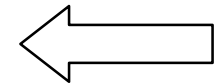

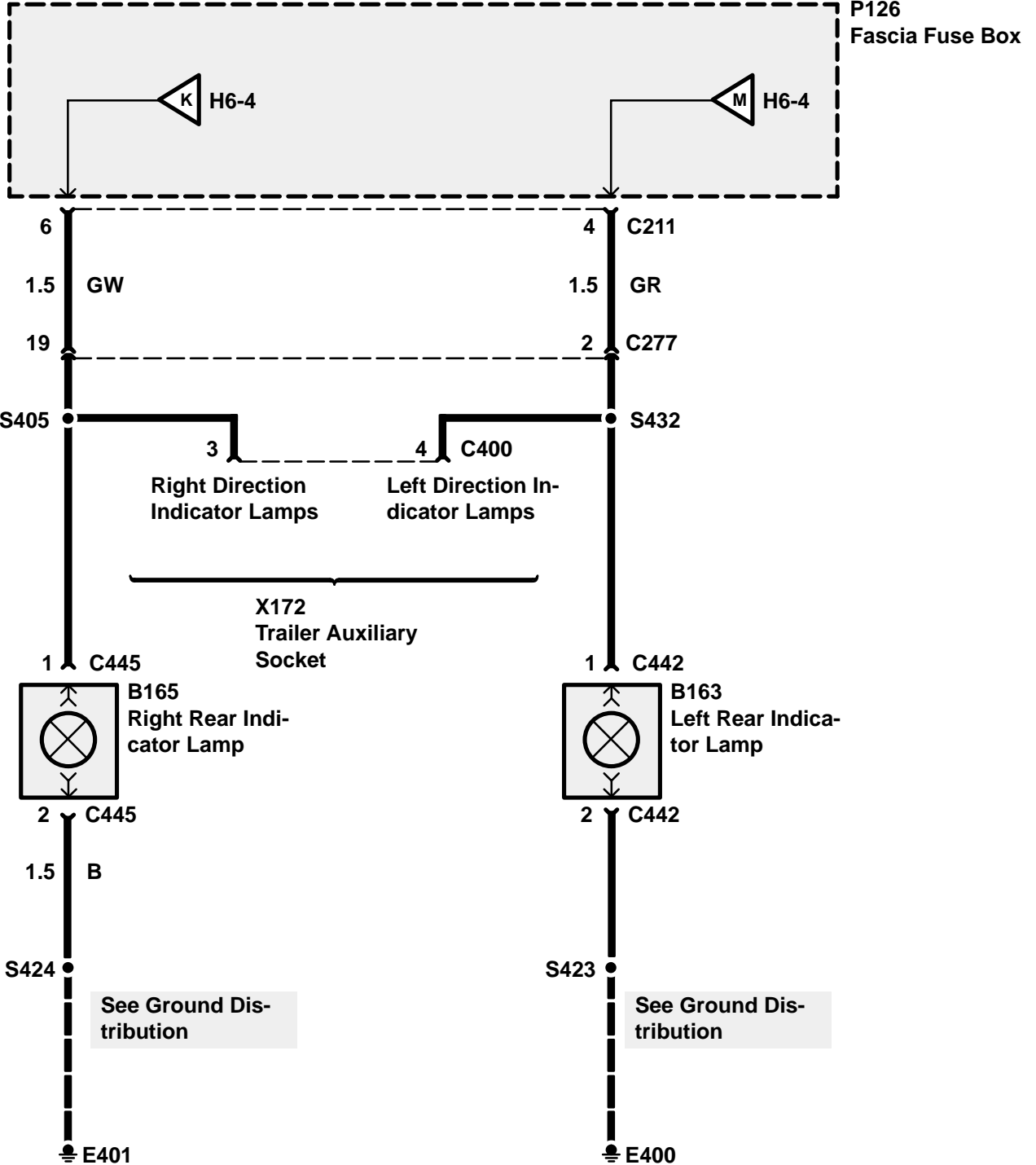
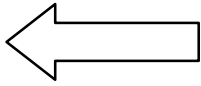

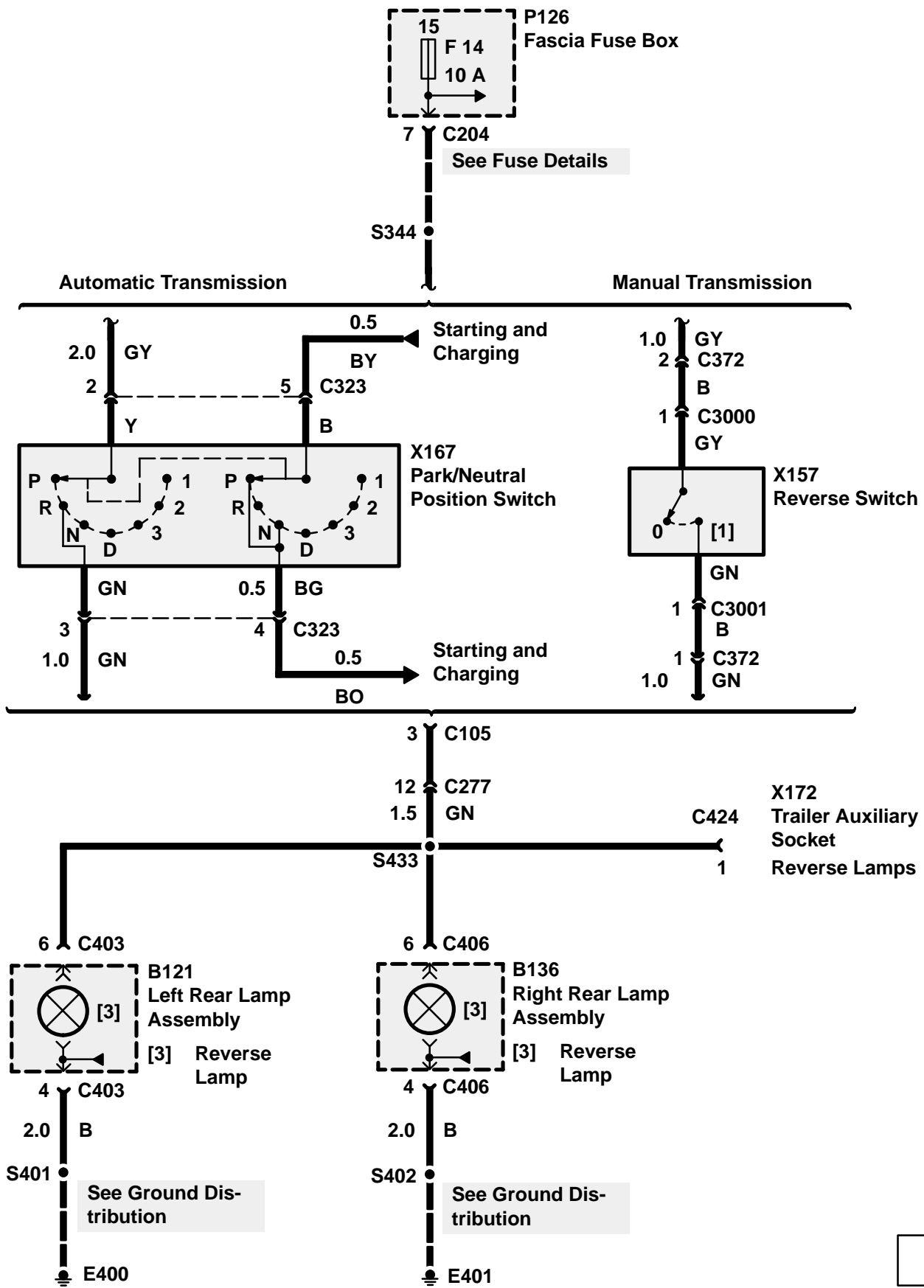



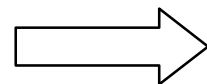
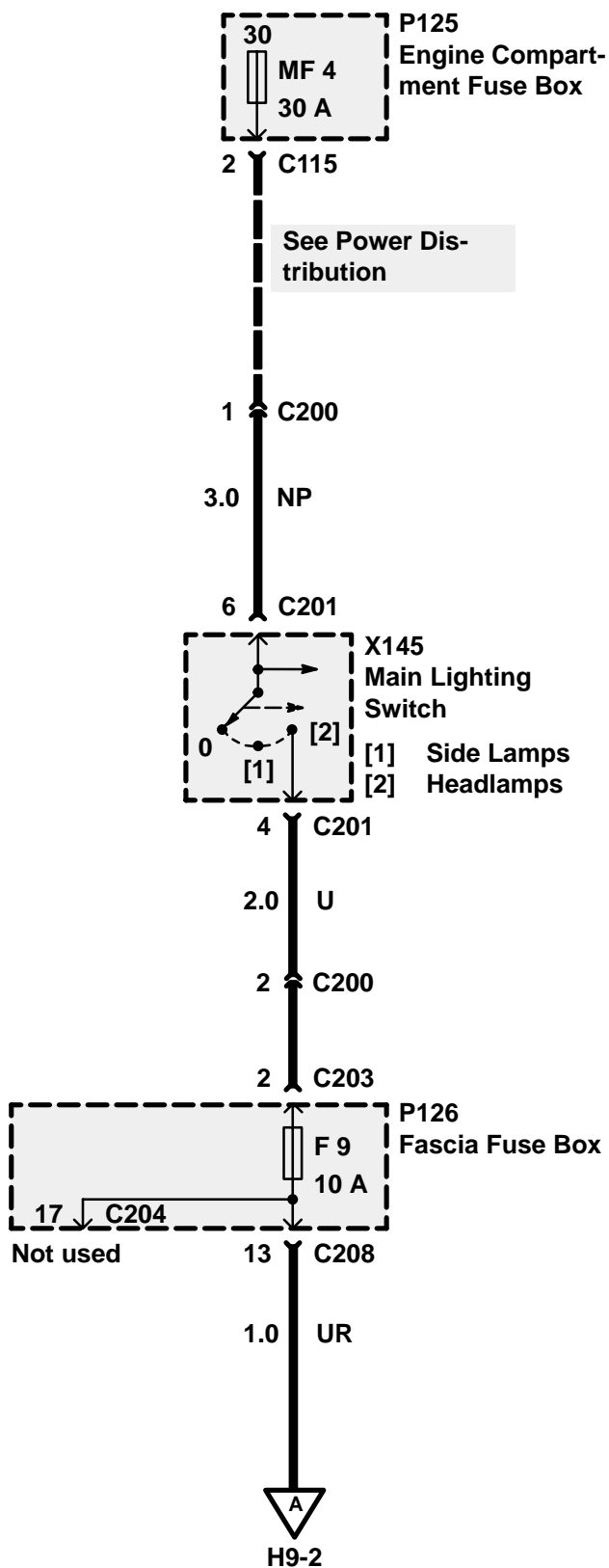

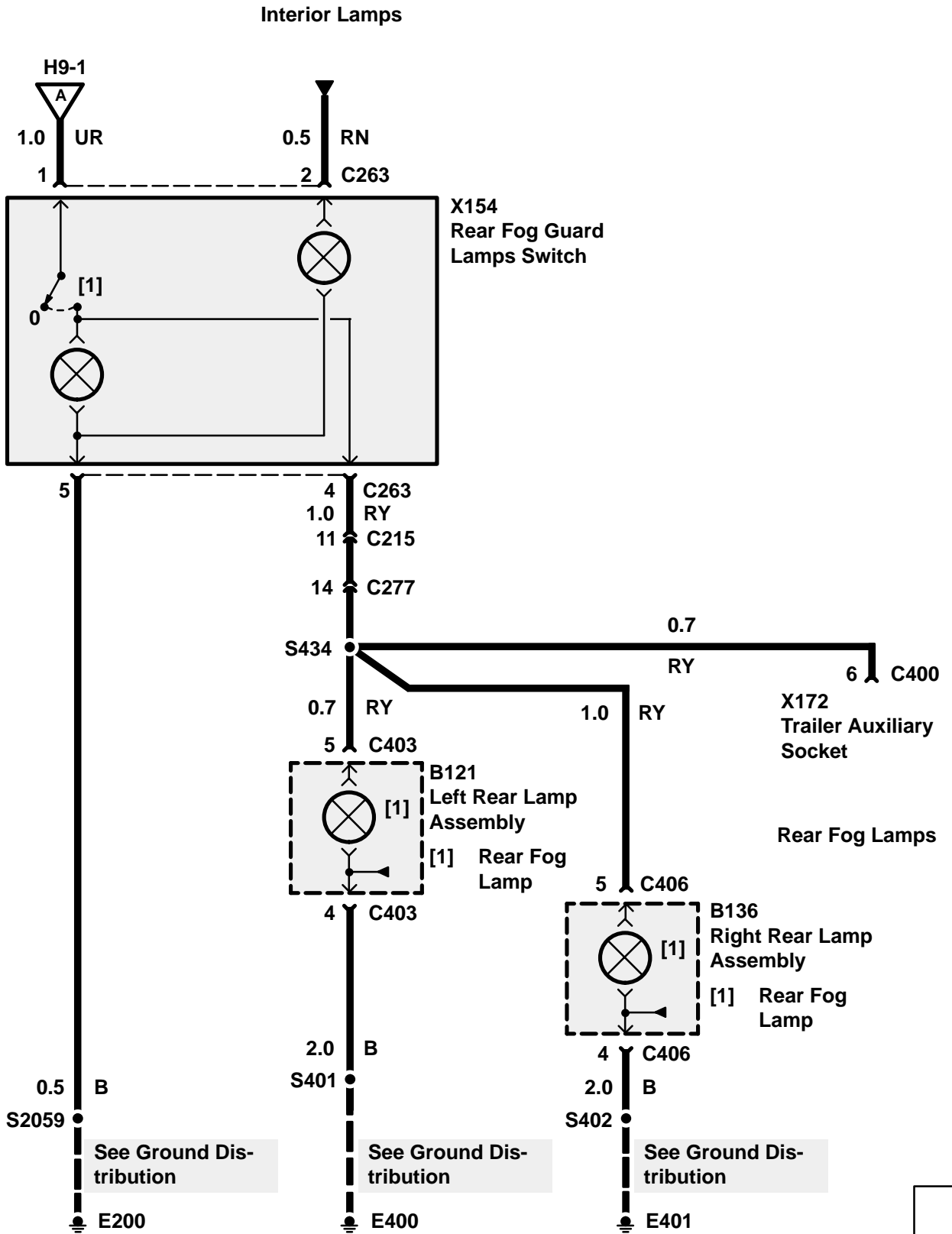
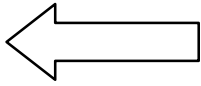

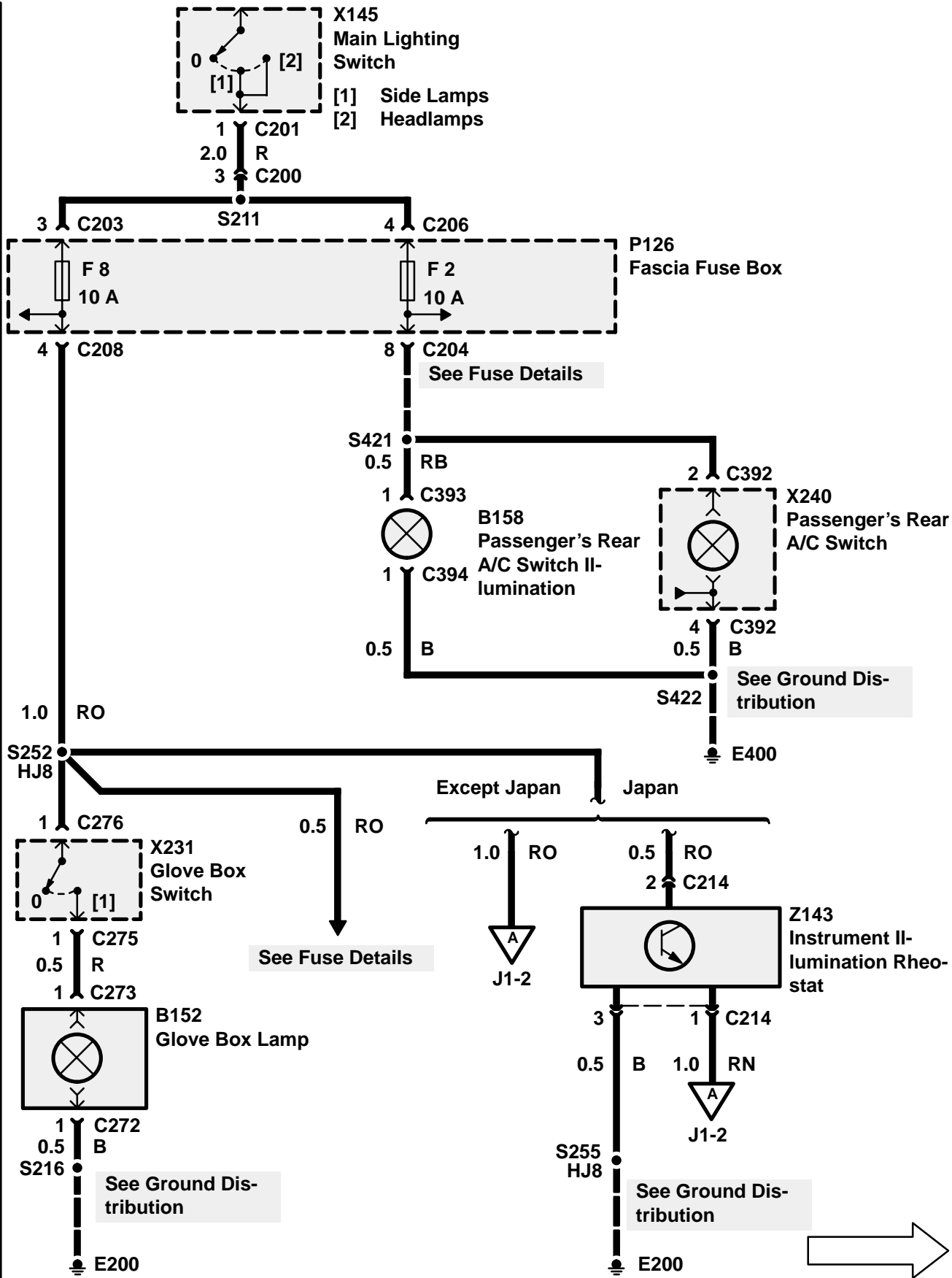

# J1 ETM

## DISCOVERY

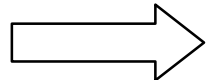
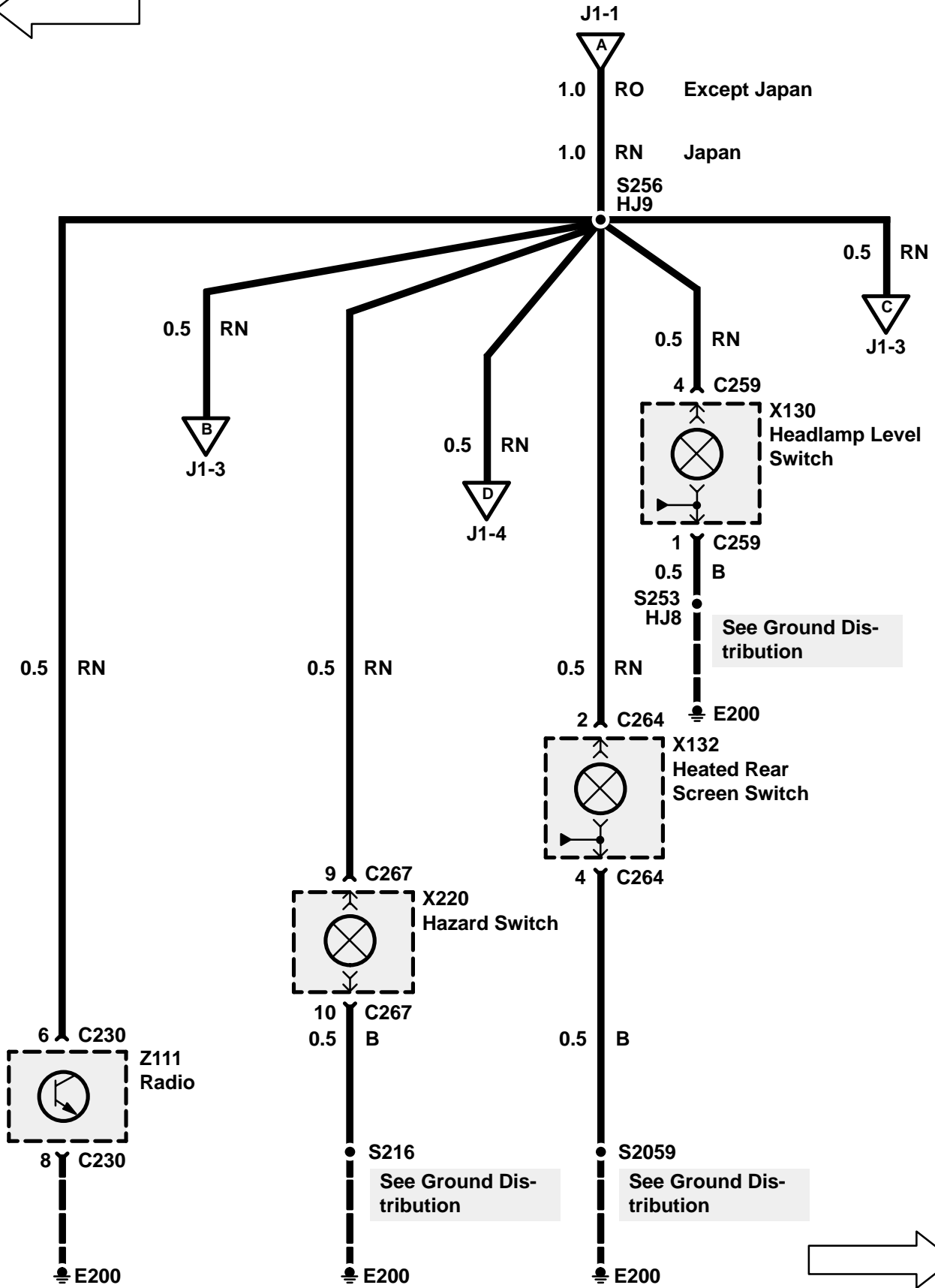
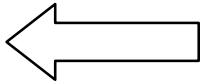

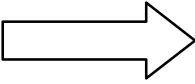
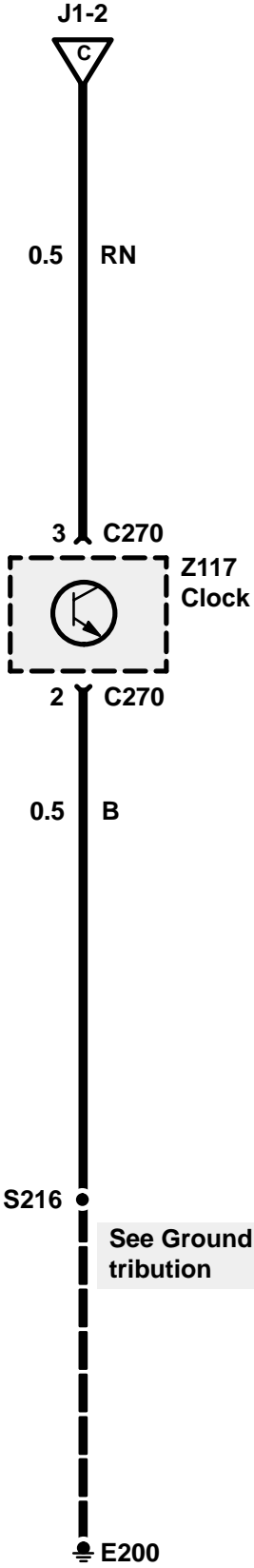
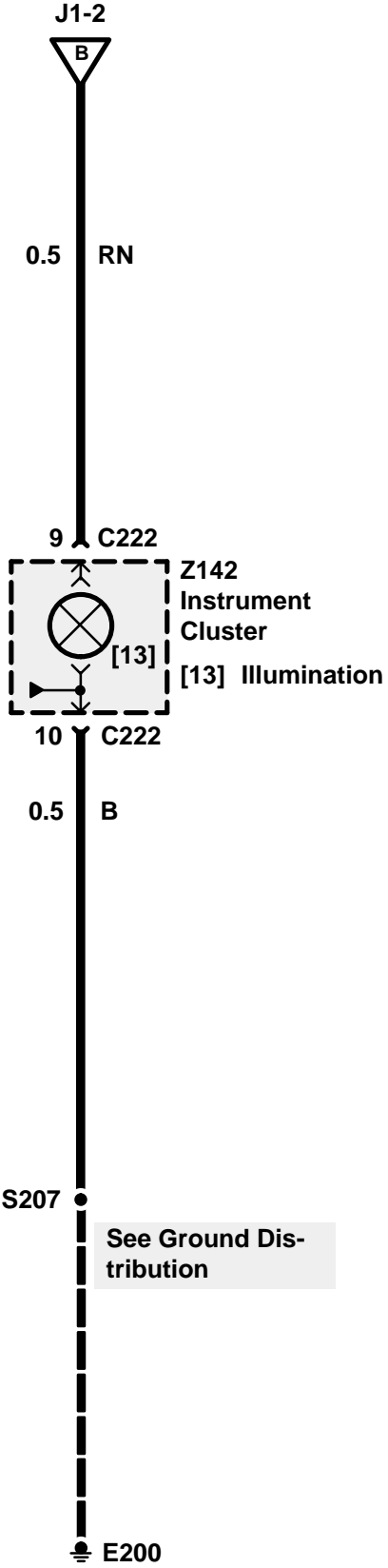
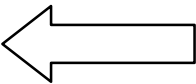

# J1 ETM

## DISCOVERY

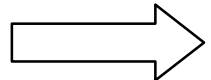
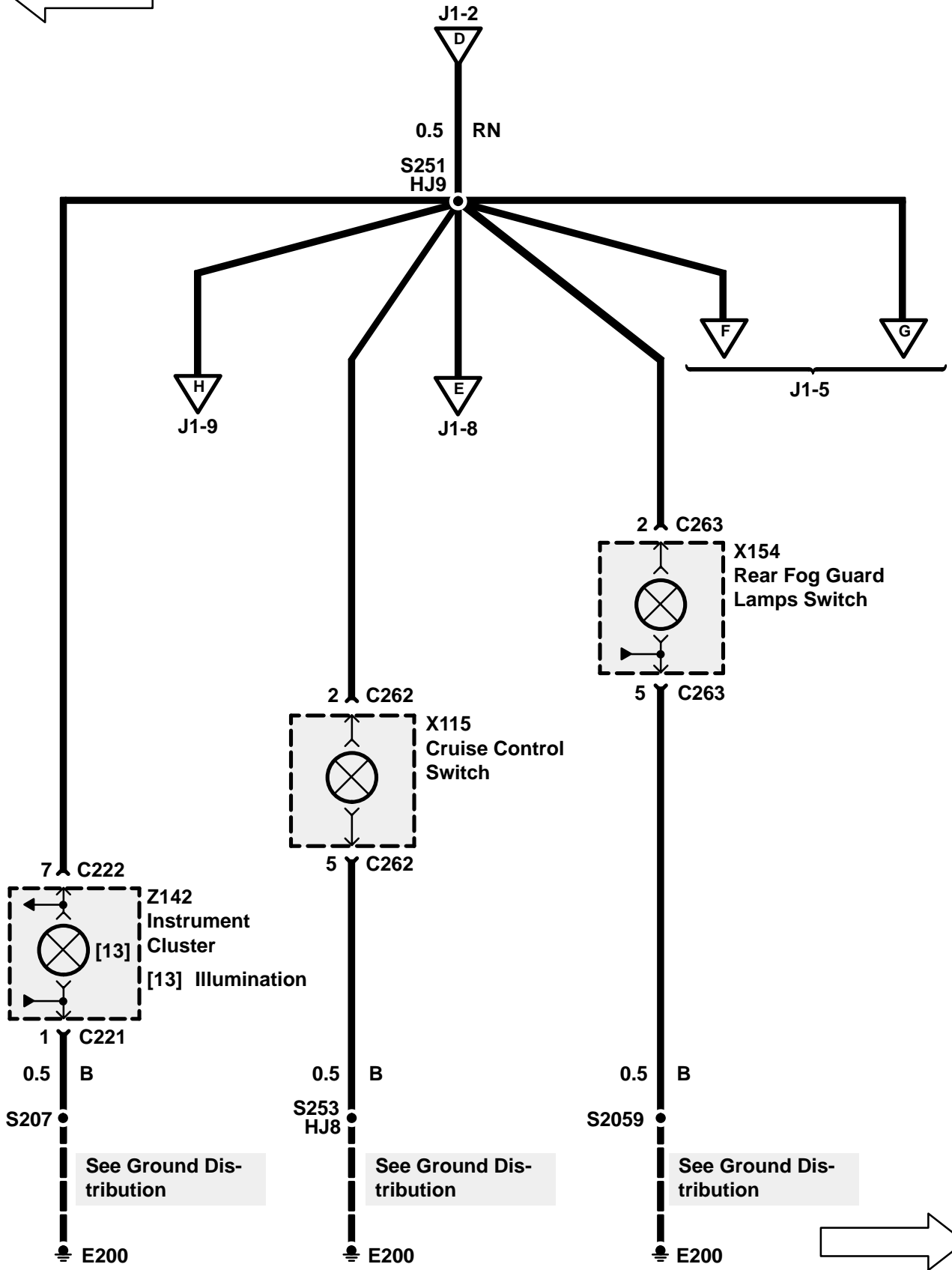
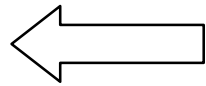

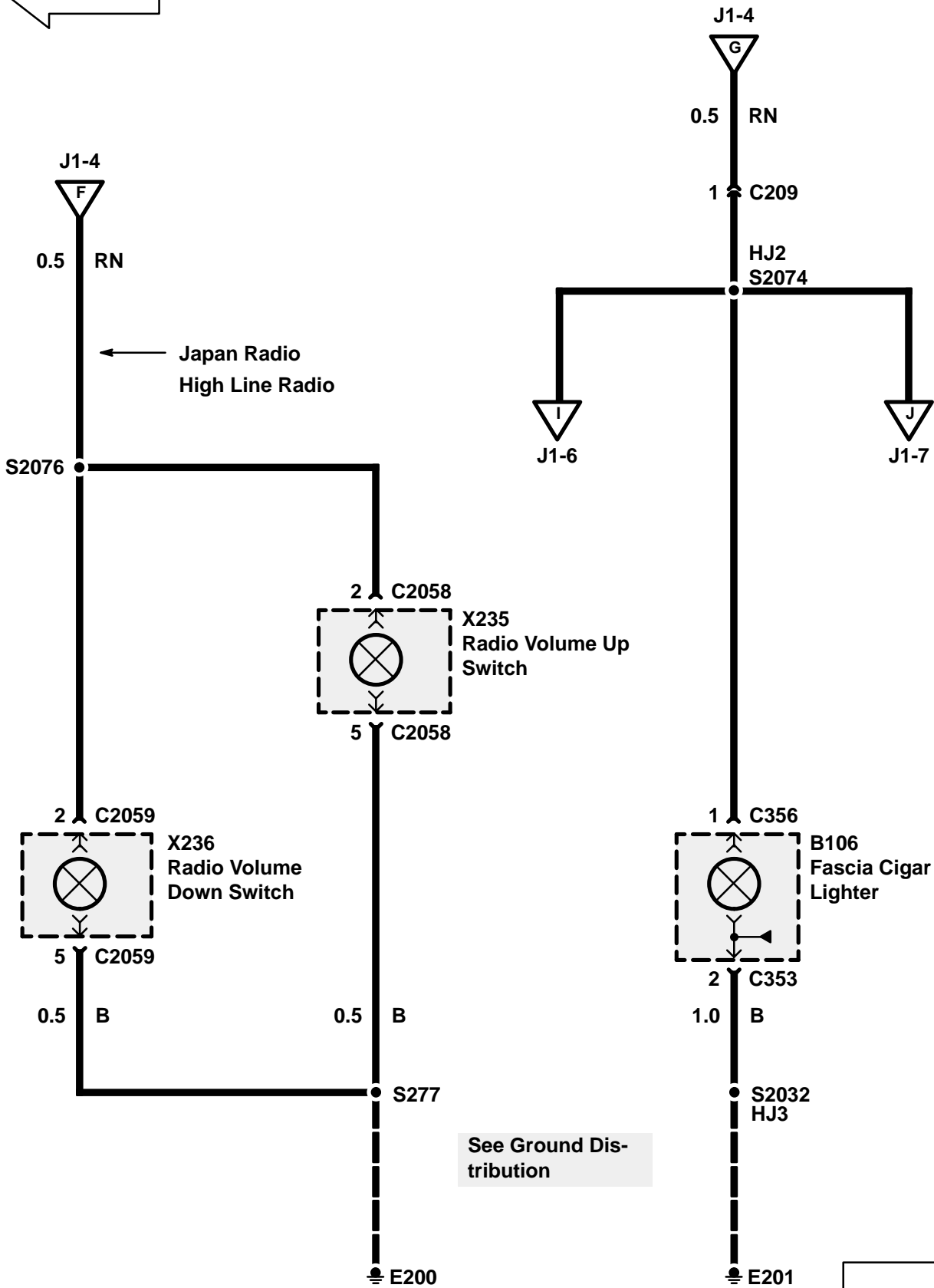
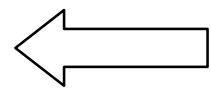

See Ground Dis-  
tribution

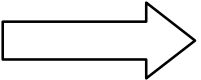

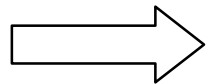
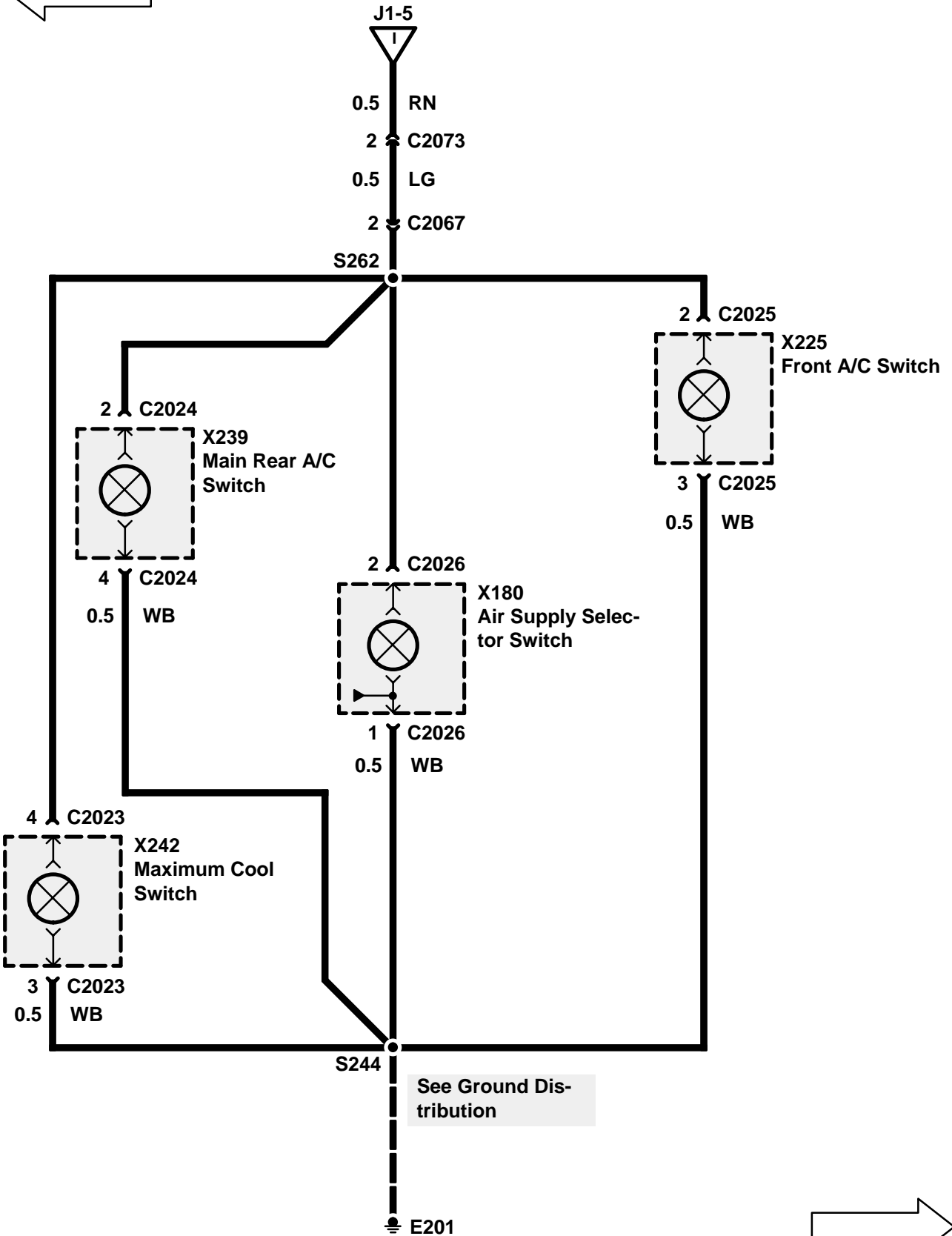
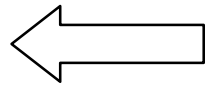



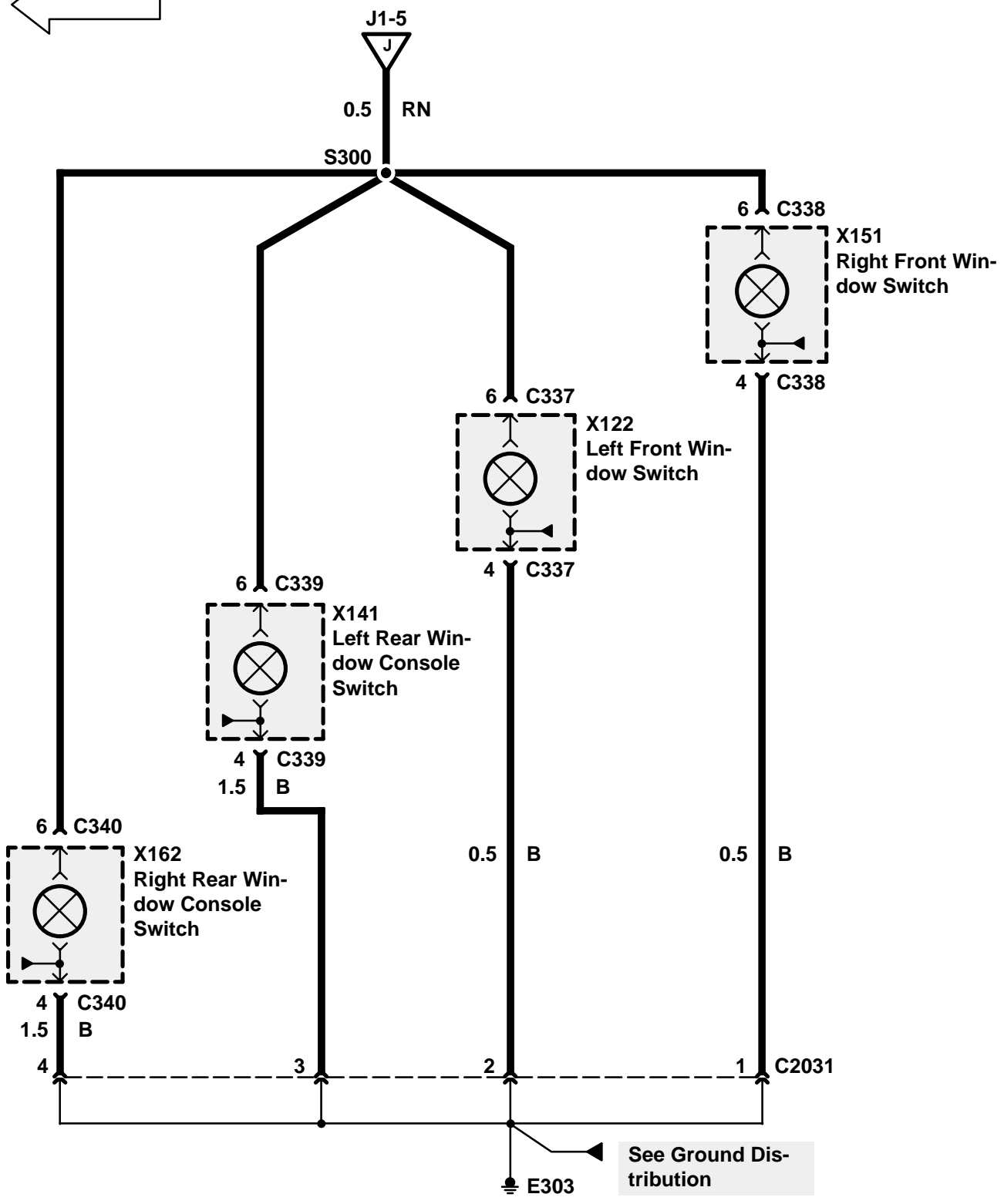
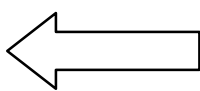

See Ground Distribution

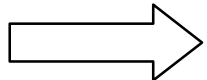

# J1 ETM

## DISCOVERY

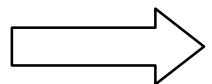
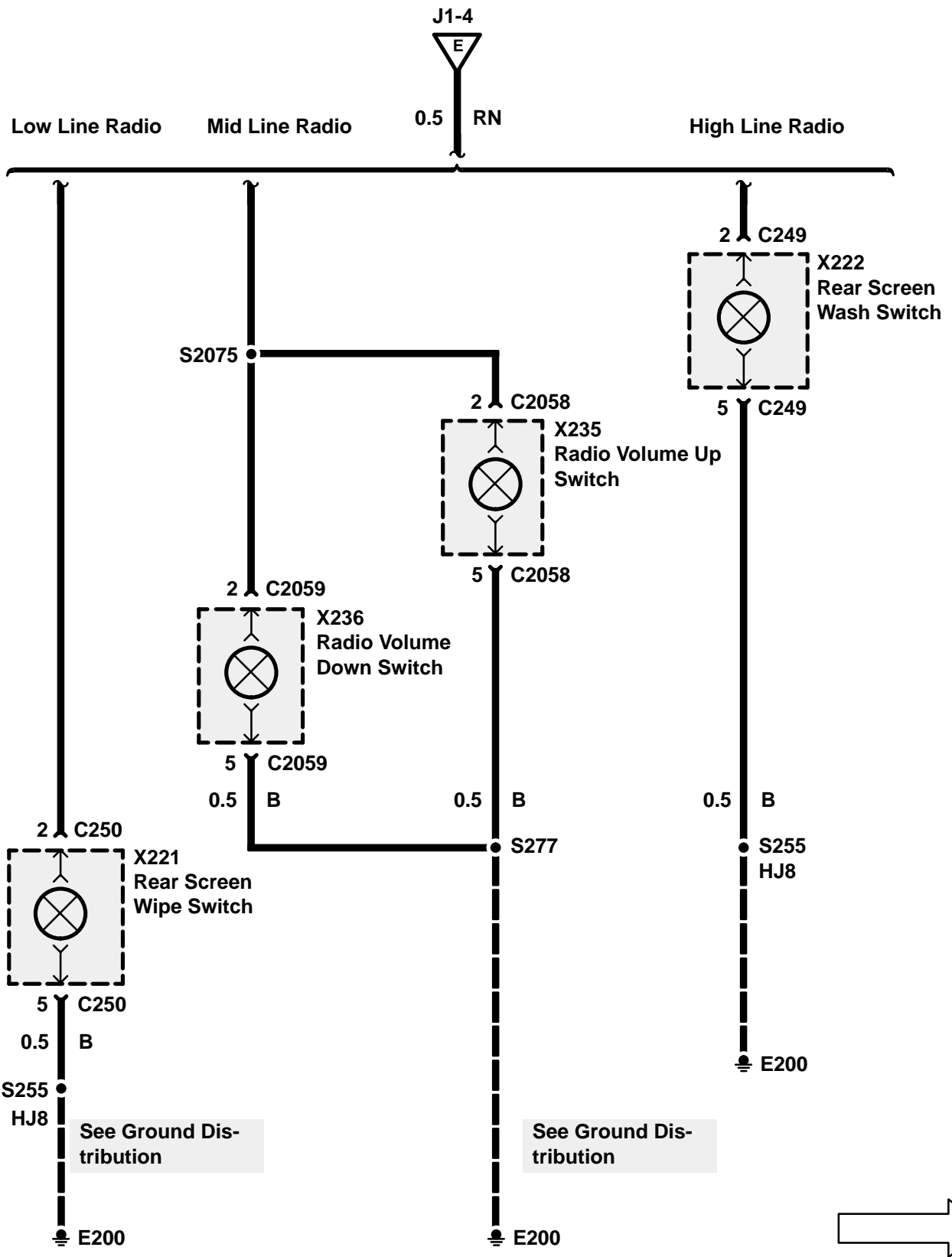
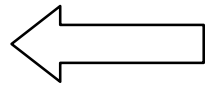

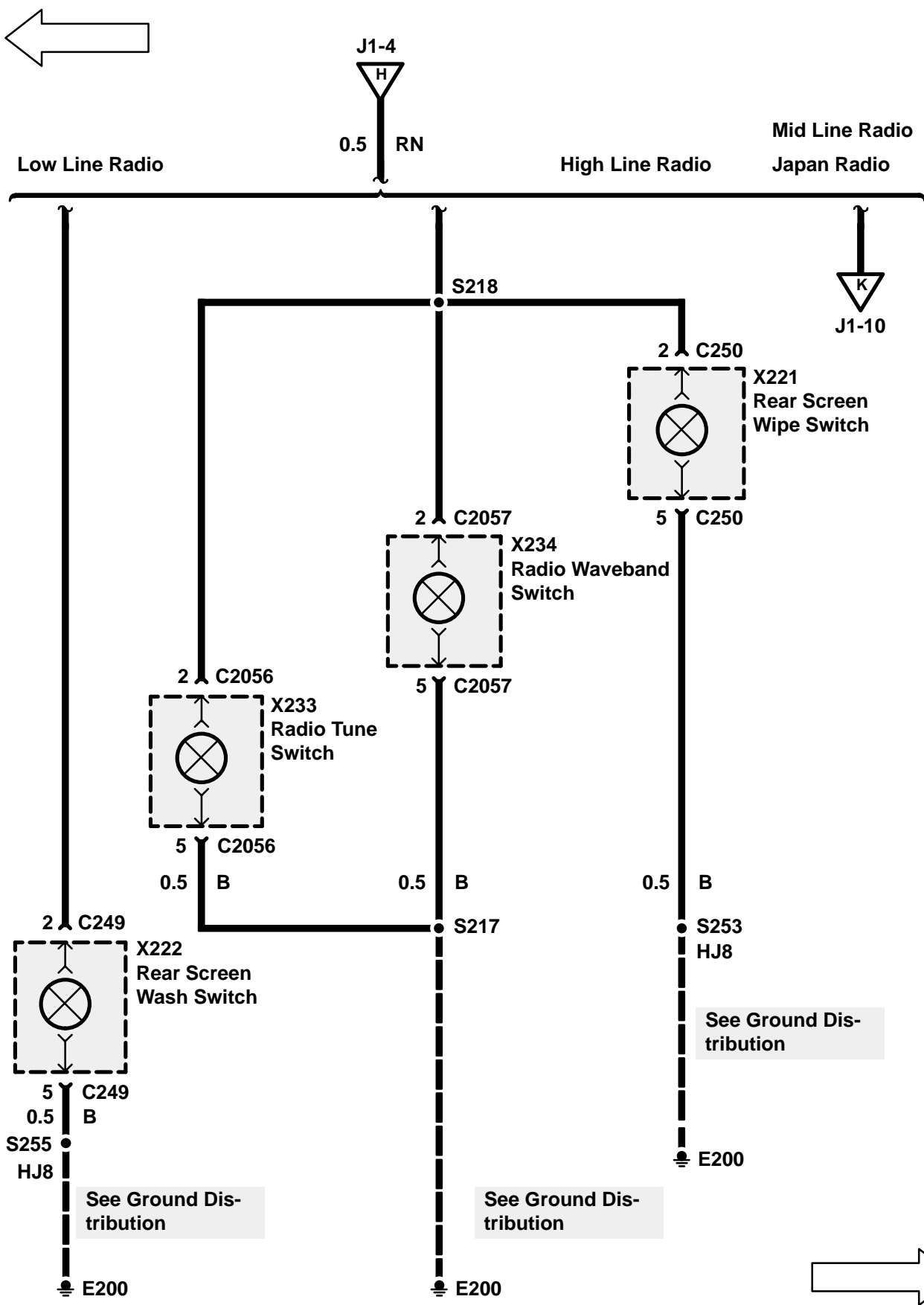

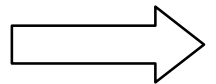
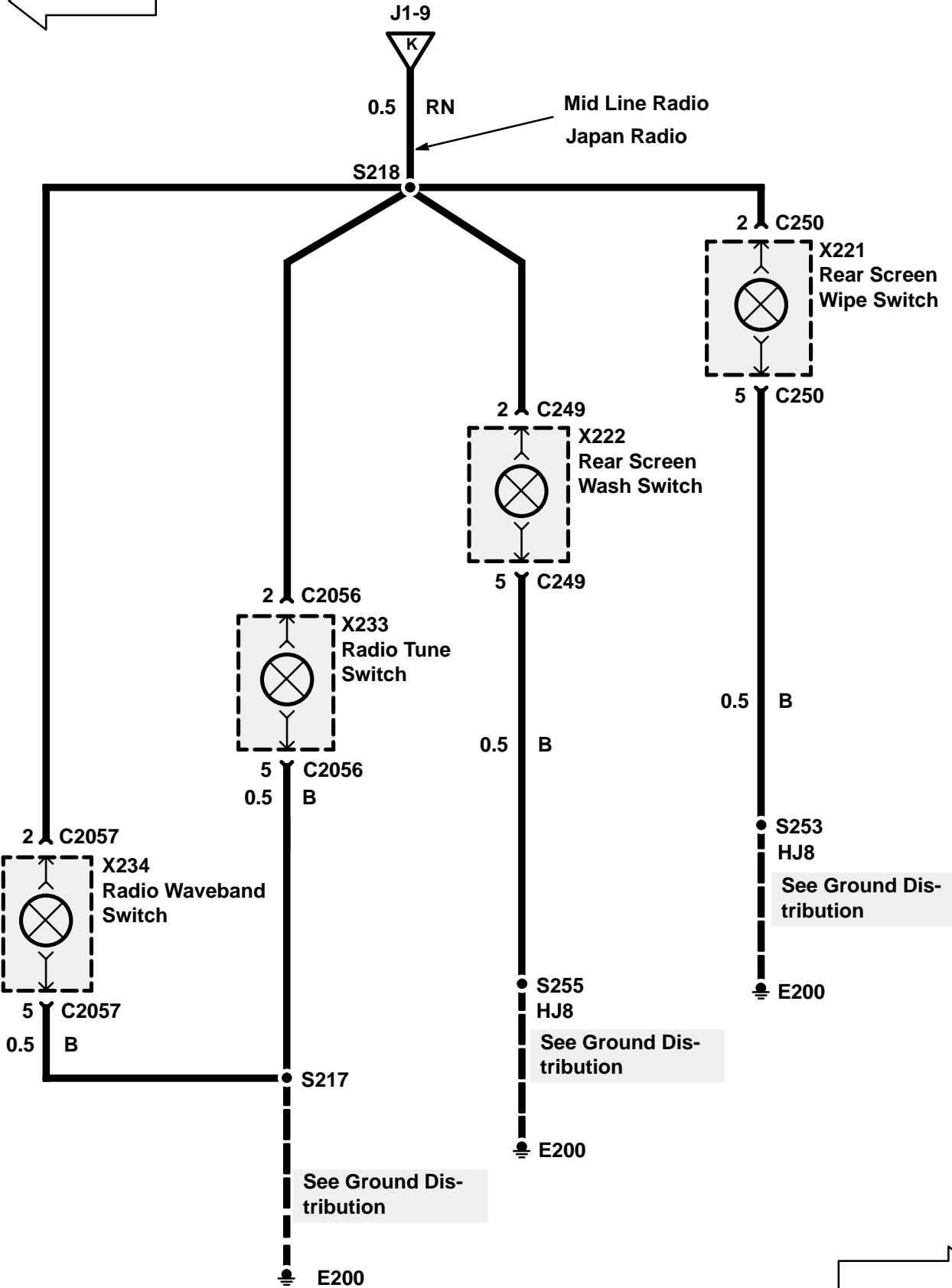
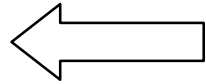

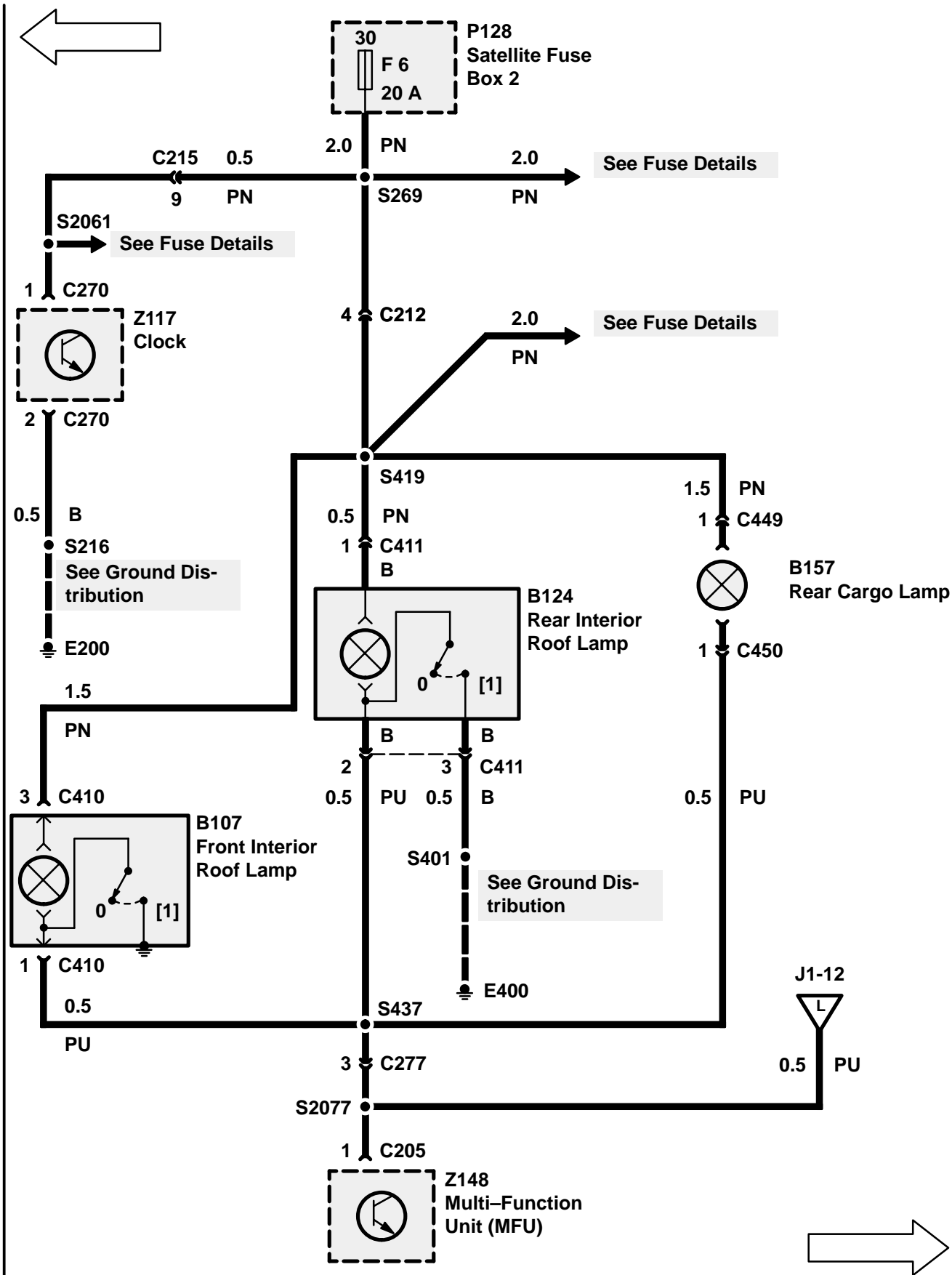

# J1 ETM

## DISCOVERY

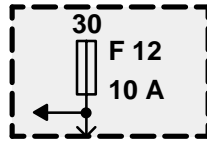
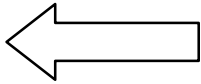

P126  
Fascia Fuse Box

4 C204

See Fuse Details

19 C202  
0.5 PN

Without Shift Interlock

With Shift Interlock

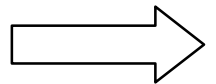
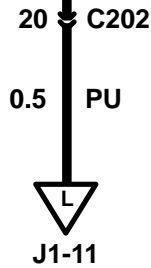
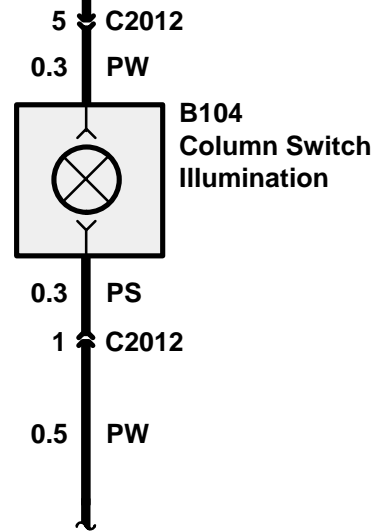
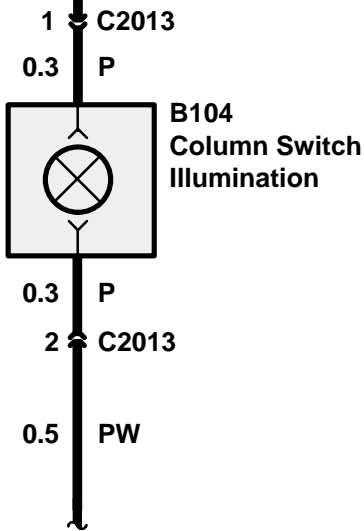

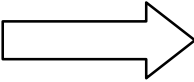
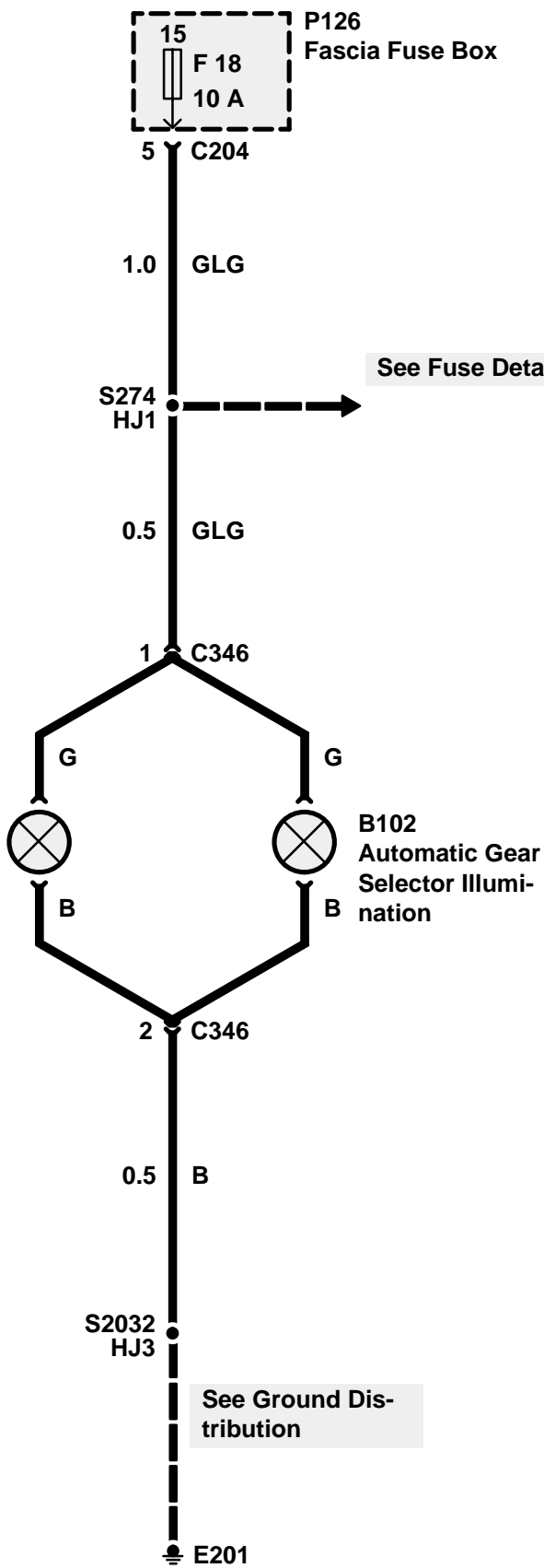
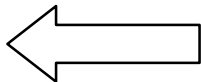

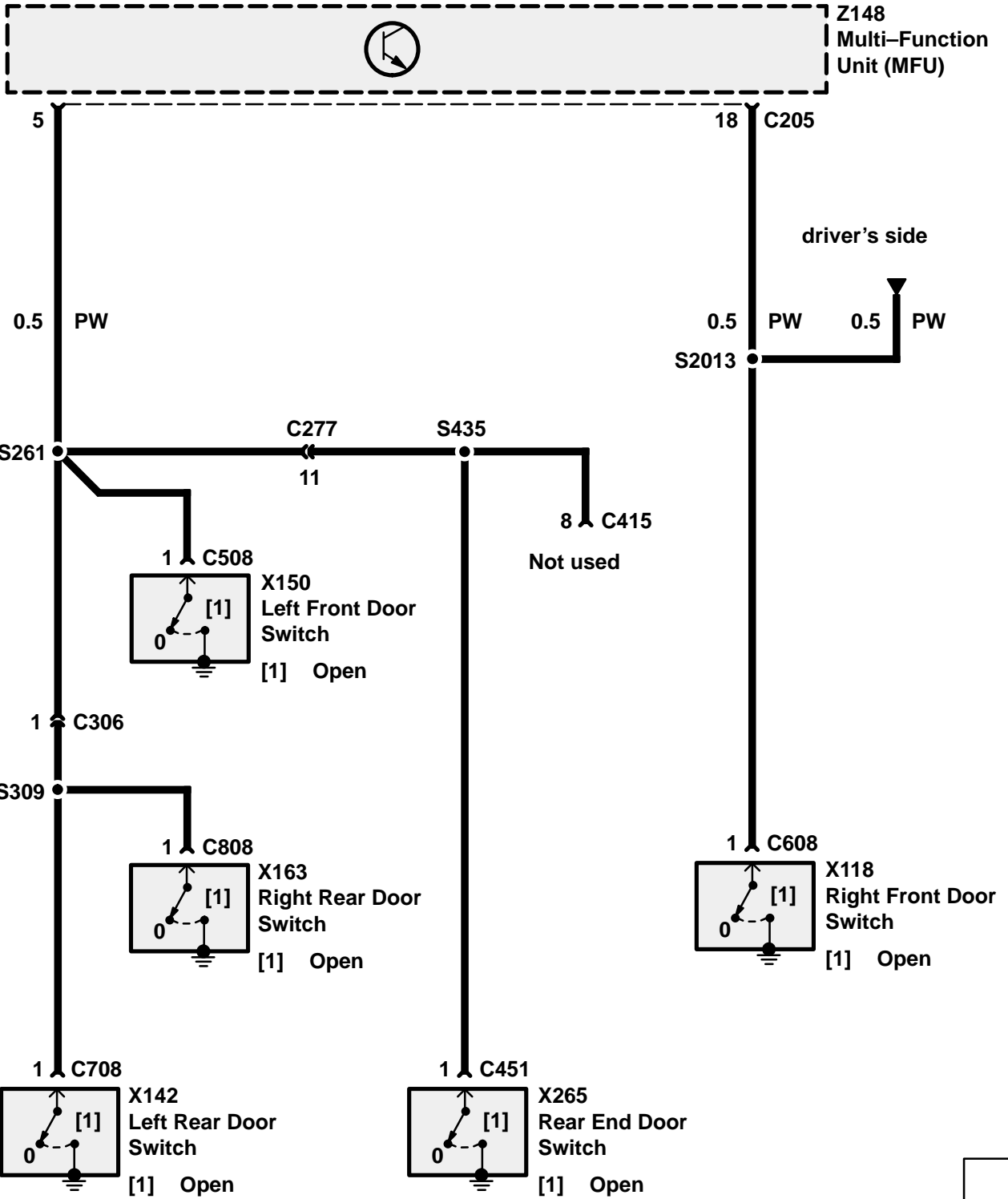
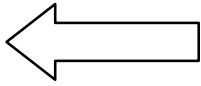



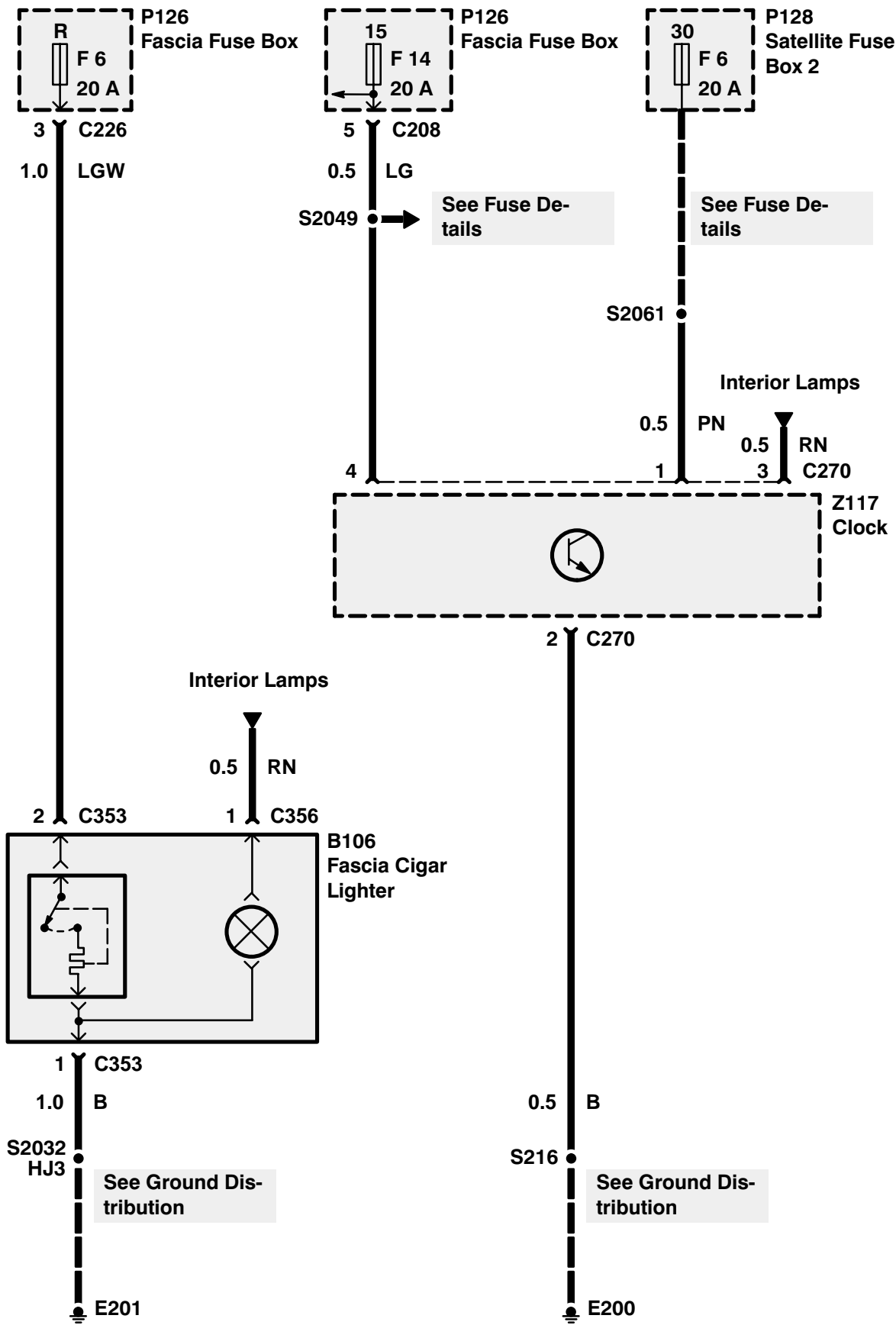

## CIRCUIT OPERATION

### Front Blower

With the Ignition Switch (X134) in position II, battery voltage is applied to the Ignition Load Relay (K127). The relay is energized, applying battery voltage to the Front Blower Motor Relay (K192).

When the Front Fan Speed Switch (X247) is turned to position I, ground is applied to terminal 85 of the Front Blower Motor Relay (K192). The relay is energized, applying battery voltage to terminal 2 of the Front Blower Motor (M101). Ground is applied to the Front Blower Motor (M101) through all three resistors of the Front Blower Resistor Unit (Z214). The Front Blower Motor (M101) then runs at low speed. When the Front Fan Speed Switch (X247) is turned to position II, the Front Blower Motor Relay (K192) remains energized. Battery voltage is still applied to terminal 2 of the Front Blower Motor (M101). Ground is now applied to the Front Blower Motor (M101) through two resistors of the Front Blower Resistor Unit (Z214) and the Front Fan Speed Switch (X247). The motor then runs at the low-medium speed. When the Front Fan Speed Switch (X247) is turned to position III, the Front Blower Motor Relay (K192) remains energized. Ground is now applied to the Front Blower Motor (M101) through one resistor of the Front Blower Resistor Unit (Z214) and the Front Fan Speed Switch (X247). The motor then runs at the medium-high speed. When the Front Fan Speed Switch (X247) is turned to position IV, the Front Blower Motor Relay (K192) remains energized. Ground is now applied directly to the Front Blower Motor (M101) through the Front Fan Speed Switch (X247). The motor then runs at high speed.

### Fresh Air Mode

With the Ignition Switch (X134) in position II, battery voltage is applied to the Ignition Load Relay (K127). The relay is energized, applying battery voltage to the Air Recirculation Solenoid In-Line Fuse (P138) and Air Recirculation Solenoid (K123). When the Air Supply Selector Switch is moved to the Fresh Air position, ground is applied to the Air Recirculation Solenoid (K123). The solenoid now opens the fresh air intake flap allowing fresh air to enter the vehicle cabin. When the fresh air intake flap has been fully opened, the microswitch inside the Air Recirculation Solenoid (K123) moves to the

Fresh Air position interrupting the ground supply. The solenoid now stops and remains in the Fresh Air position.

### Recirculated Air Mode

With the Ignition Switch (X134) in position II, battery voltage is applied to the Ignition Load Relay (K127). The relay is energized, applying battery voltage to the Air Recirculation Solenoid In-Line Fuse (P138) and Air Recirculation Solenoid (K123). When the Air Supply Selector Switch is moved to Recirculate Air position, ground is applied to the Air Recirculation Solenoid (K123). The solenoid now closes the fresh air intake flap allowing only the air inside the vehicle cabin to circulate. When the fresh air intake flap has been fully closed, the microswitch inside the Air Recirculation Solenoid (K123) moves to the Recirculate Air position interrupting the ground supply. The solenoid now stops and remains in the Recirculate Air position.

### Heated Air

With the Ignition Switch (X134) in position II, battery voltage is applied to the Ignition Load Relay (K127). The relay is energized, applying battery voltage to the Left Maximum Cool Switch (X267). When the Left and Right Temperature Controls are turned to the maximum cool position, the Left Maximum Cool Switch (X267) and Right Maximum Cool Switch (X268) close. Battery voltage is now applied to the Water Valve (K206). The Water Valve (K206) closes and prevents heated engine coolant from entering the heater matrix. When one or both of the Temperature Controls are not in the maximum cool position, battery voltage is not applied to the Water Valve (K206). The valve then opens and allows heated engine coolant to enter the heater matrix.

### Rear Blower

With the Ignition Switch (X134) in position II, battery voltage is applied to the Ignition Load Relay (K127). The relay is energized, applying battery voltage to the Rear Blower Motor Relay (K193), the Rear A/C Fan Speed Relay (K205) and the Rear A/C Control Relay (K194).

When the Rear A/C System is turned on, the Rear A/C Switch Amplifier provides ground to the Rear A/C Control Relay (K194). The relay is energized, applying ground to the Rear A/C Fan Speed Relay (K205). The Rear A/C Fan Speed Relay (K205) then energizes. When the Passenger's Rear Fan Speed Switch (X246) is turned to position I, ground is applied to terminal 85 of the Rear Blower Motor Relay (K193) through the closed switch contacts of the Rear A/C Fan Speed Relay (K205). The Rear Blower Motor Relay (K193) energizes, applying battery voltage to terminal 1 of the Rear Blower Motor (M145).

Ground is applied to the Rear Blower Motor (M145) through all three resistors of the Rear Blower Resistor Unit (Z215). The Rear Blower Motor (M145) then runs at low speed. When the Passenger's Rear Fan Speed Switch (X246) is turned to position II, the Rear Blower Motor Relay (K193) remains energized. Battery voltage is still applied to terminal 1 of the Rear Blower Motor (M145). Ground is now applied to the Rear Blower Motor (M145) through two resistors of the Rear Blower Motor Resistor Unit (Z215) and the Passenger's Rear Fan Speed Switch (X246). The

motor then runs at the low–medium speed. When the Passenger's Rear Fan Speed Switch (X246) is turned to position III, the Rear Blower Motor Relay (K193) remains energized. Ground is now applied to the Rear Blower Motor (M145) through one resistor of the Rear Blower Motor Resistor Unit (Z215) and the Passenger's Rear Fan Speed Switch (Z246).

The motor then runs at medium–high speed. When the Passenger's Rear Fan Speed Switch (X246) is turned to position IV, the Rear Blower Motor Relay (K193) remains energized. Ground is now applied directly to the Rear Blower Motor (M145) through the Passenger's Rear Fan Speed Switch (X246). The motor then runs at high speed.





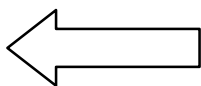

Interior Lamps

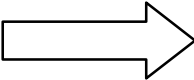
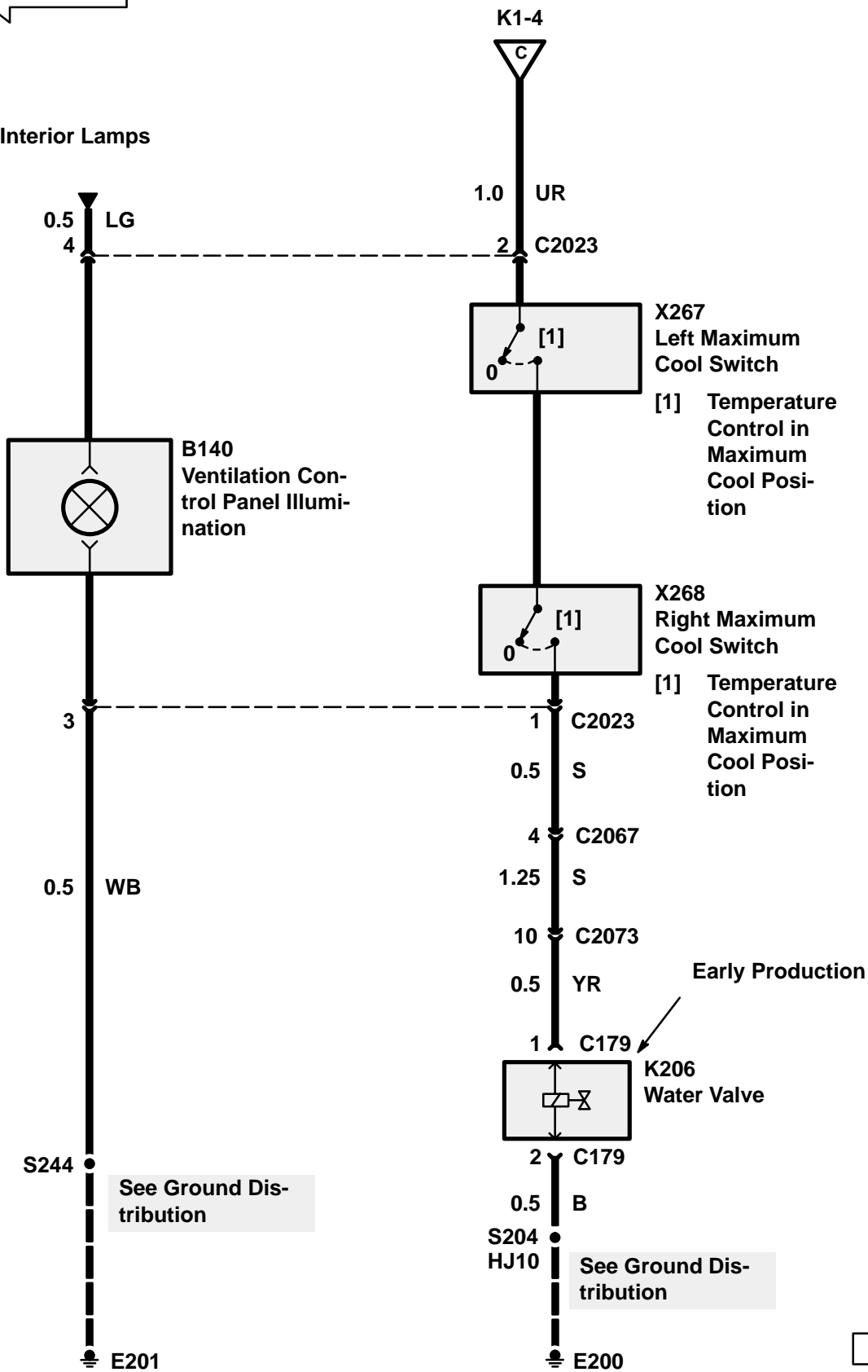

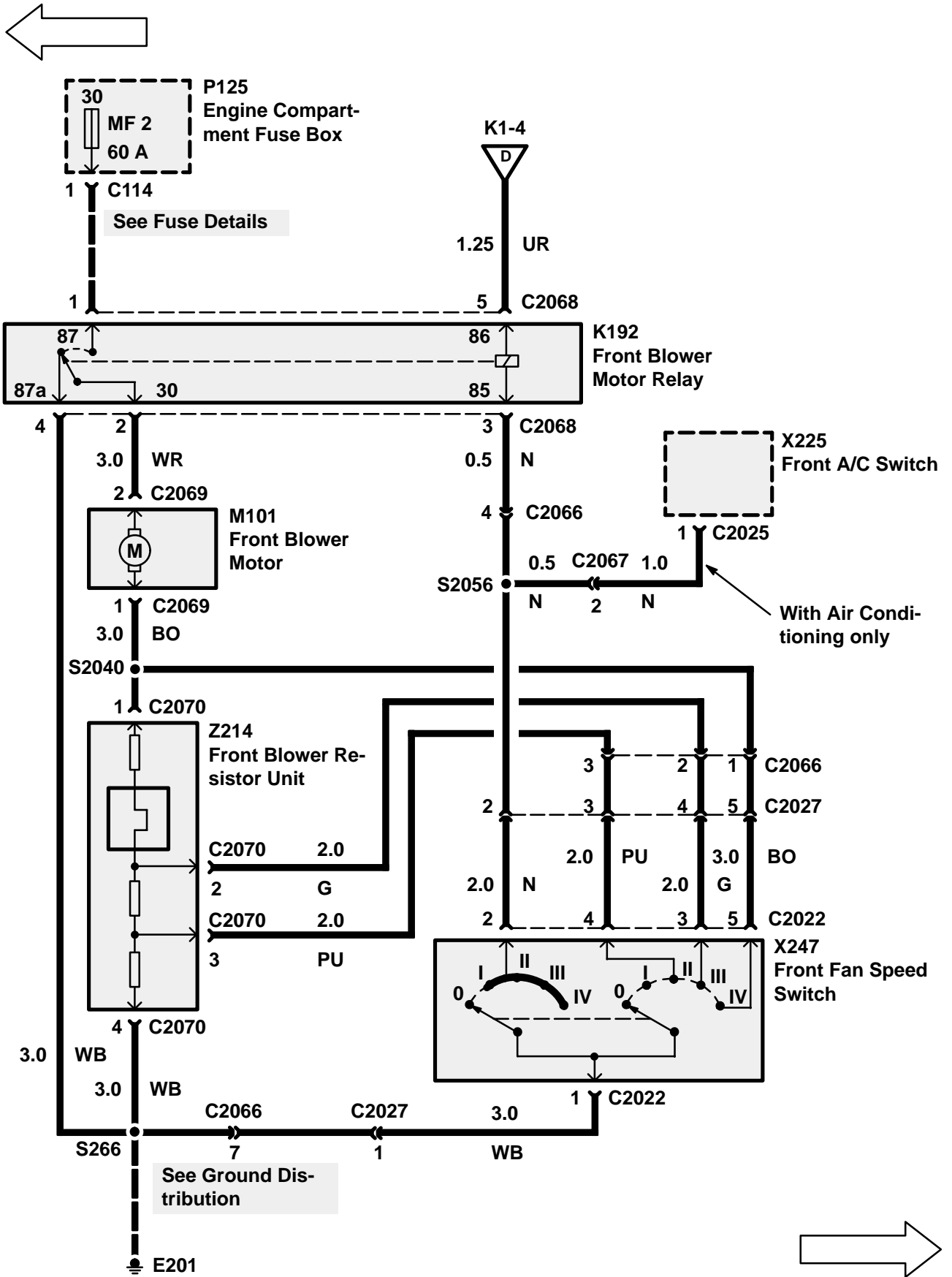

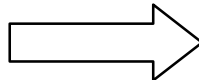
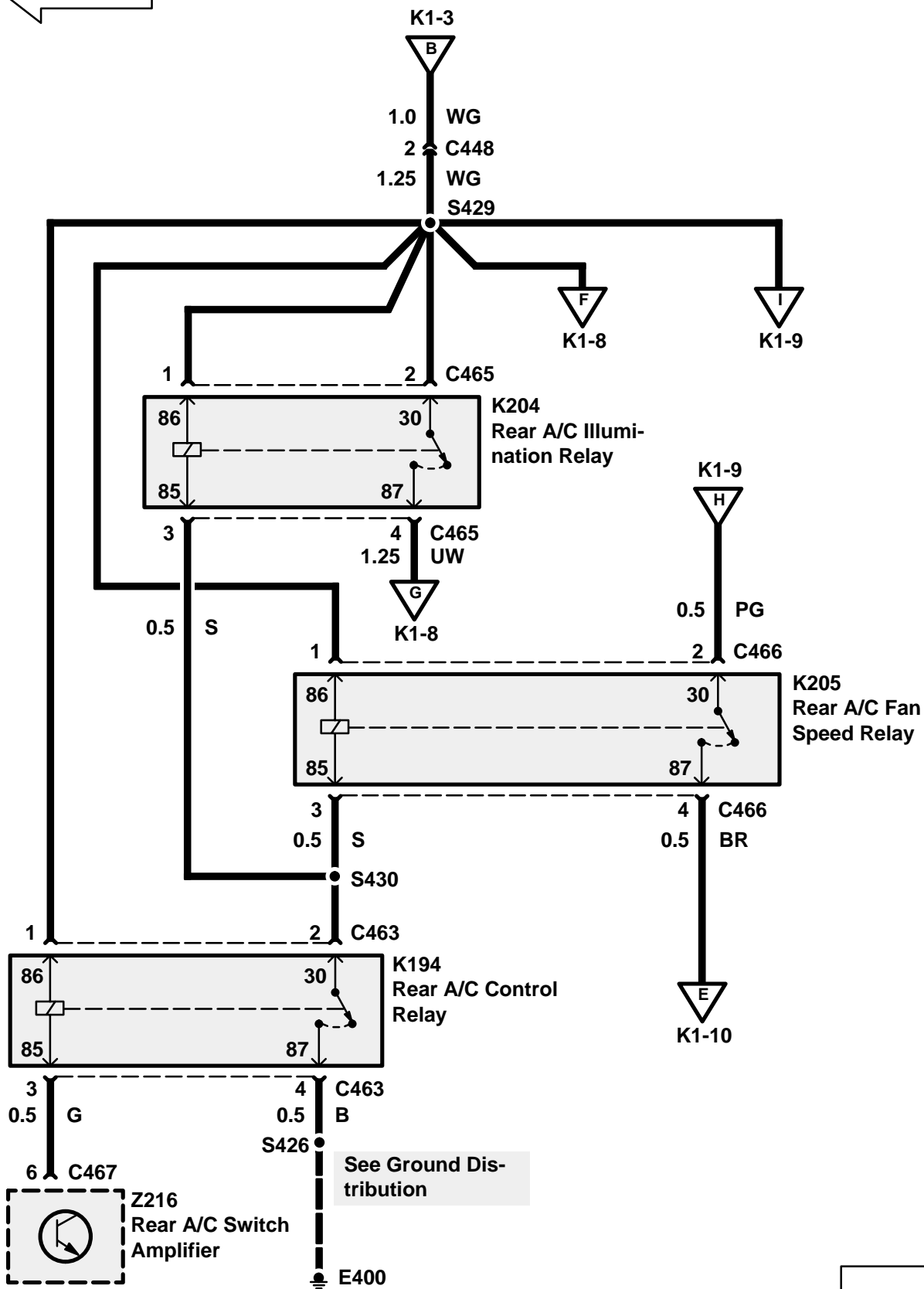
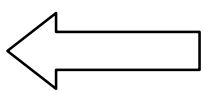



# K1 ETM

## DISCOVERY

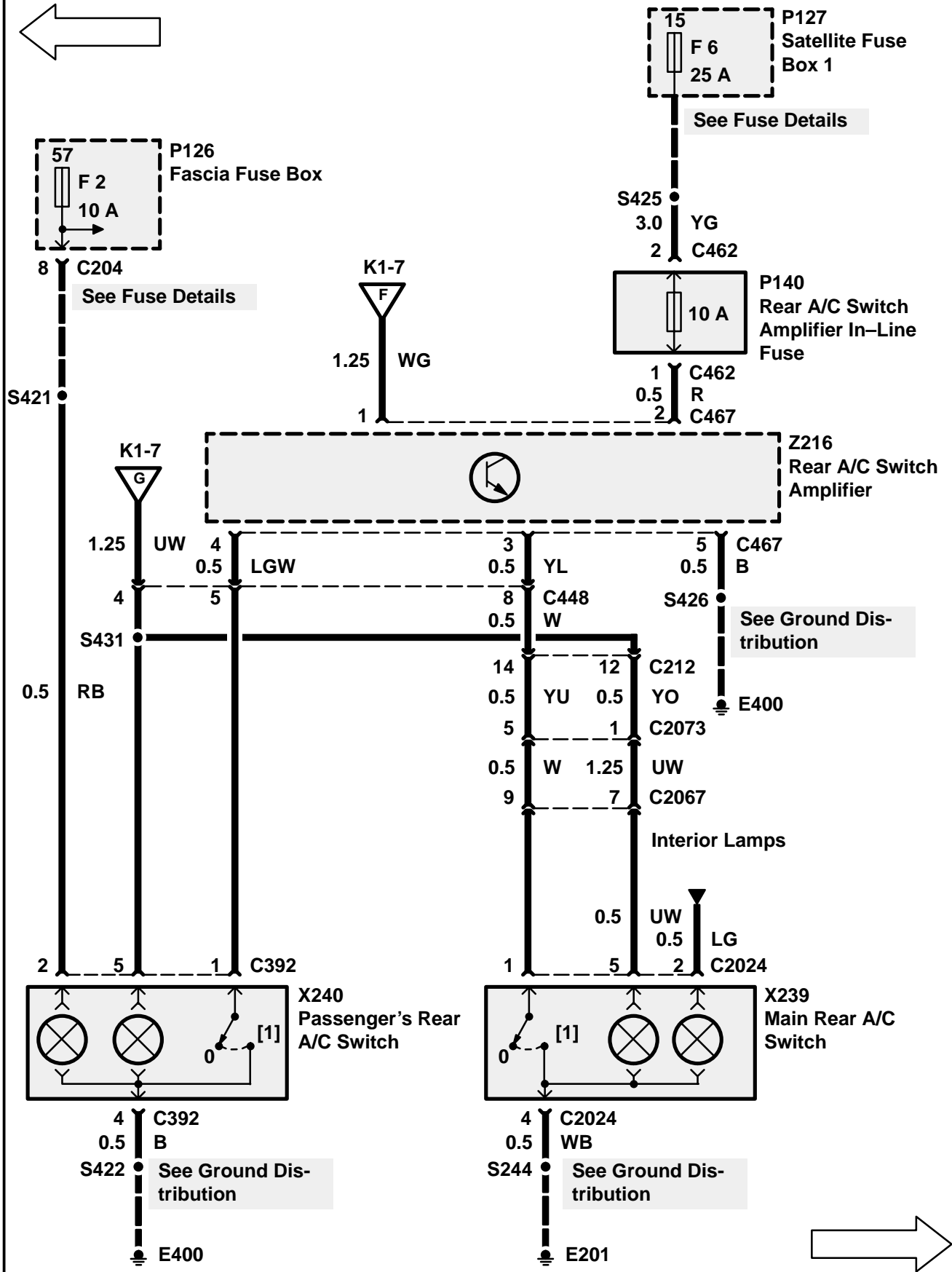



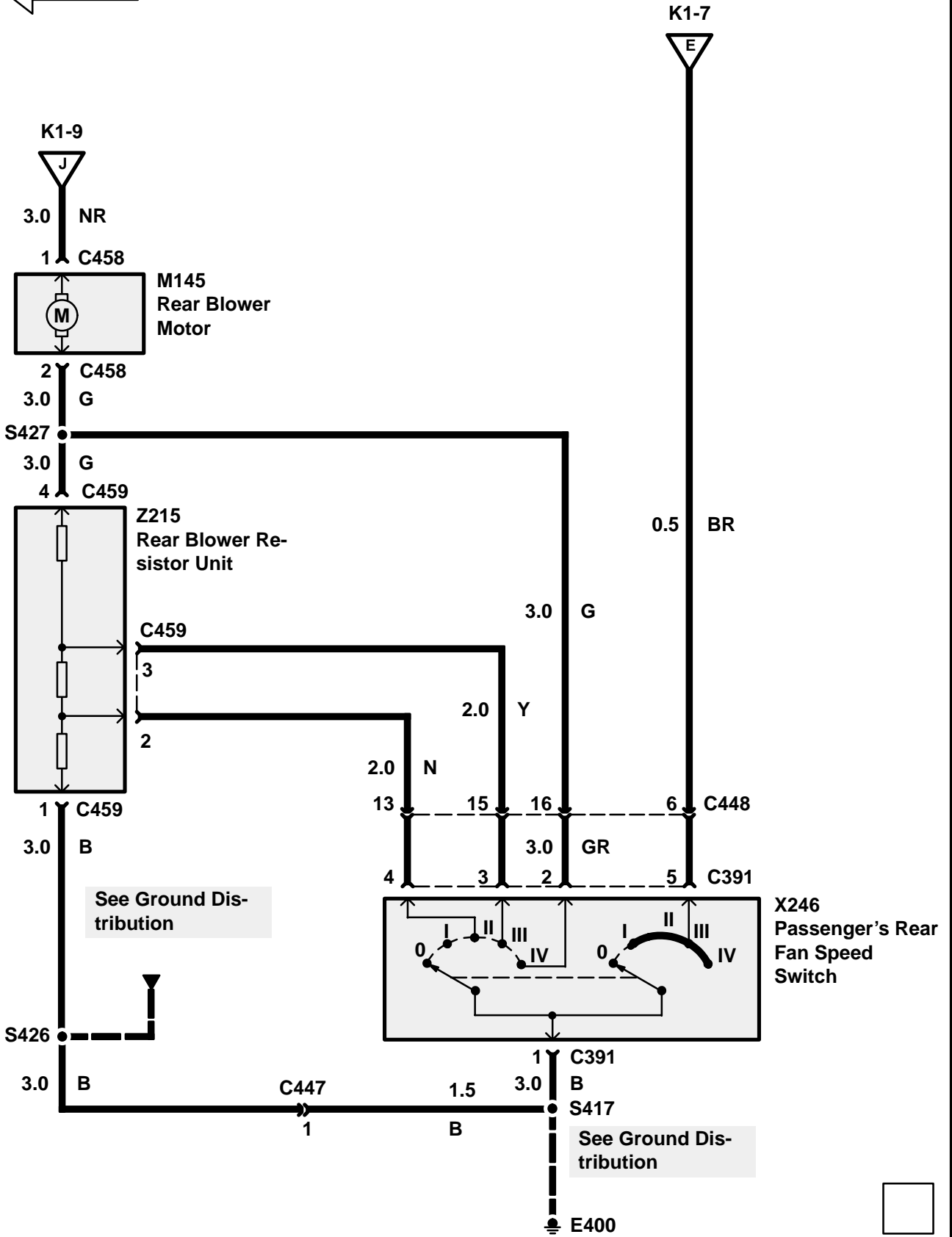
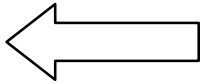

**TROUBLESHOOTING HINTS**

4. Check Maxi-Fuse<sup>®</sup> MF2 of the Engine Compartment Fuse Box (P125).
  5. Check Fuse F15 of the Fascia Fuse Box (P126).
  6. Check Fuse F6 of the Satellite Fuse Box 1 (P127).
  7. If the Front Blower Motor (M101) does not stop running with the Front Fan Speed Switch (X247) in Position 0, replace the Front Fan Speed Switch (X247).
  8. If the Rear Blower Motor (M145) does not stop running with the Passenger's Rear Fan Speed Switch (X246) in Position O, replace the Passenger's Rear Fan Speed Switch (K246).
  9. If fresh air does not enter the vehicle cabin with the Air Supply Selector Switch (X180) in the Fresh Air position, check the Air Recirculation Solenoid (K123) and linkage for sticking or binding.
  10. If the blower motor(s) operate with the ignition key removed, replace the Ignition Load Relay (K127).
  11. If the blower motor(s) run but not at the speed indicated by the Fan Speed Switches (X179), replace the appropriate Fan Speed Switch.
7. With the engine running and the Fan Speed Switch (X179) in position III, put the Air Supply Selector Switch (X180) to Recirculation mode. Place a piece of paper in front of the fresh air intake vents on the vehicle hood. If the paper is drawn toward the vents, do Test D.
  8. With the engine running and the Fan Speed Switch (X179) in position III, put the Air Supply Selector Switch (X180) to Fresh Air Mode. Place a piece of paper in front of the recirculation air intake vents. If the paper is drawn toward the intake, do Test D.

**SYSTEM DIAGNOSIS**

1. If the Blower Motor(s) do not run at any speed, do Test A.
2. If the Front Blower Motor (M101) does not run at any speed, but the Rear Blower Motor (M145) operates correctly, do Test B.
3. If the Rear Blower Motor (M145) does not run at any speed, but the Front Blower Motor (M101) operates correctly, do Test E.
4. If the Front Blower Motor (M101) runs in some but not all Front Fan Speed Switch (X247) positions, do Test C.
5. If the Rear Blower Motor (M145) runs in some but not all Rear Fan Speed Switch (X246) positions, do Test F.
6. If the Air Supply Selector Switch (X180) does not allow the driver to change between recirculation and fresh air modes, do Test D.

### Test A

1A

R050001

**CONDITIONS**

- Ignition Switch  
*Position: II*

**RESULTS**  
*BAT VOLT*

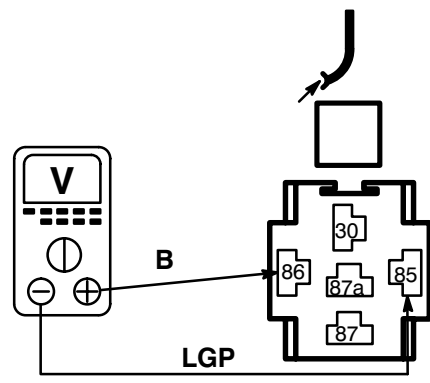

**K127**  
Ignition Load  
Relay

OK **PROBLEM CAUSE**

- F15 Fuse
- LGP Wire
- B Wire

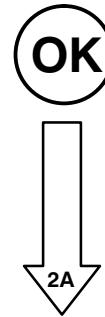

2A

R050001

**CONDITIONS**

- Ignition Switch  
*Position: 0*

**RESULTS**  
*BAT VOLT*

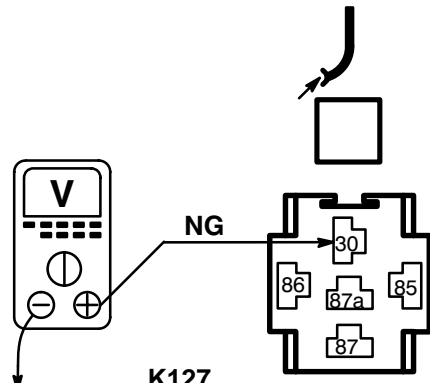

**K127**  
Ignition Load  
Relay

OK **PROBLEM CAUSE**

- F6 Fuse
- NG Wire

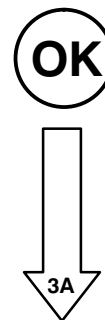

R050001

2A

3A

**CONDITIONS**

- Ignition Switch  
*Position: II*
- Front Fan Speed Switch  
*Position: III*

**RESULTS**

- Front Blower Motor  
*Operates*

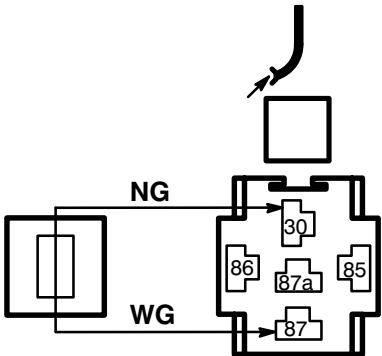

K127  
Ignition Load  
Relay

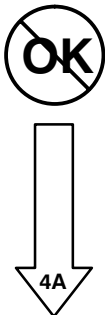

**OK** PROBLEM CAUSE  
- Ignition Load Relay

R050016

4A

**CONDITIONS**

- Ignition Switch  
*Position: 0*

**RESULTS**

*BAT VOLT*

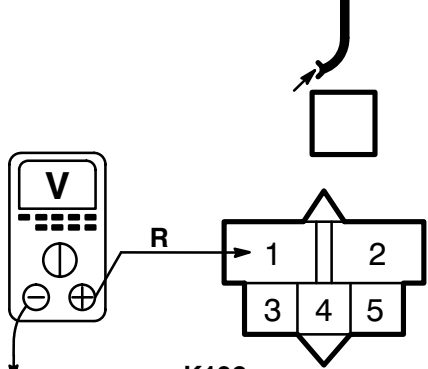

K192  
Front Blower  
Motor Relay

~~**OK**~~ PROBLEM CAUSE

- MF2 Maxi-Fuse
- NK Wire
- R Wire

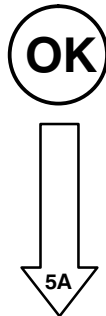

# K1 ETM

## DISCOVERY

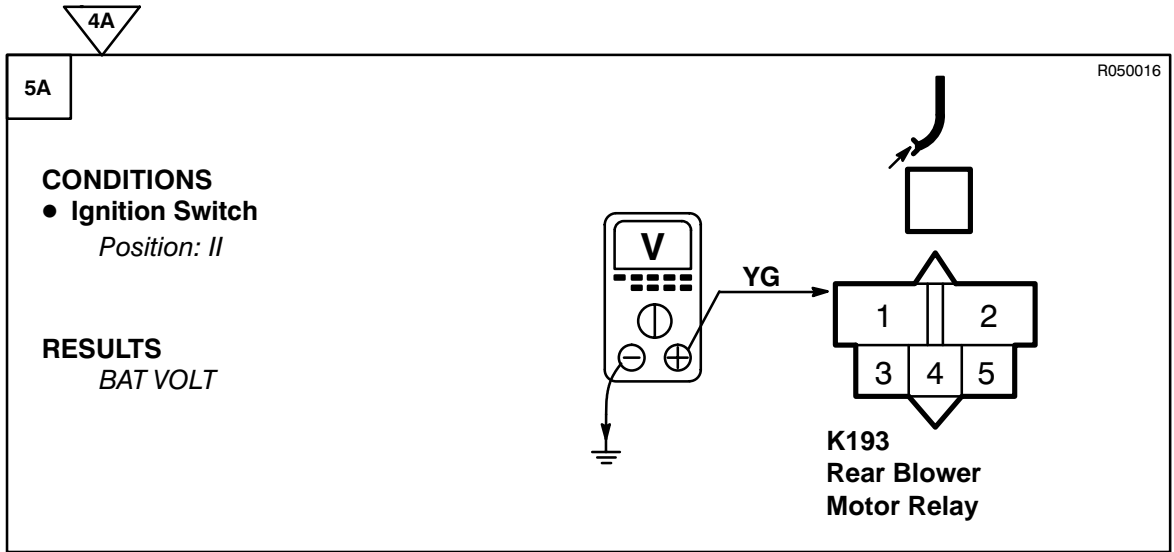

~~OK~~ **PROBLEM CAUSE**

- YG Wire
- NG Wire

OK **PROBLEM CAUSE**

- WG Wire
- UR Wire

### Test B

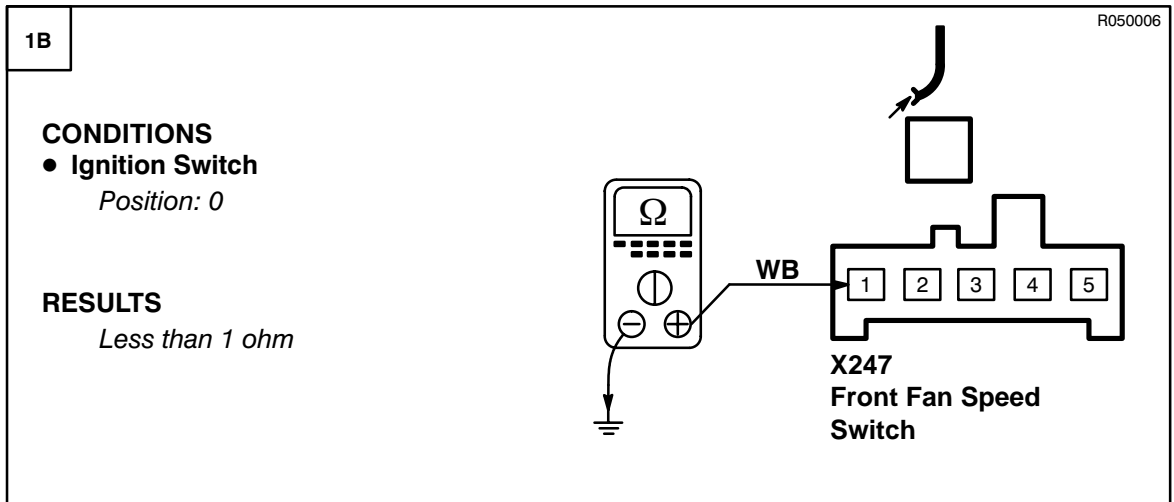

~~OK~~ **PROBLEM CAUSE**

- WB Wire
- B Wire

OK

↓

2B

R050016

**1B**

**2B**

**CONDITIONS**

- Ignition Switch  
*Position: 0*
- Front Fan Speed Switch  
*Position: I*  
*Position: II*  
*Position: III*  
*Position: IV*

**RESULTS**  
*Less than 1 ohm*

**K192**  
**Front Blower**  
**Motor Relay**

~~OK~~ **PROBLEM CAUSE**

- N Wire
- WB Wire
- Front Fan Speed Switch

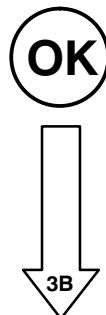

R020049

**3B**

**CONDITIONS**

- Ignition Switch  
*Position: II*
- Front Fan Speed Switch  
*Position: I*

**RESULTS**  
*BAT VOLT*

**M101**  
**Front Blower**  
**Motor**

~~OK~~ **PROBLEM CAUSE**

- WR Wire
- Front Blower Motor Relay

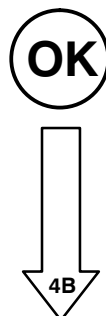



4B
3B
R040022

**CONDITIONS**

- Ignition Switch  
*Position: 0*

**RESULTS**

*Less than 1 ohm*

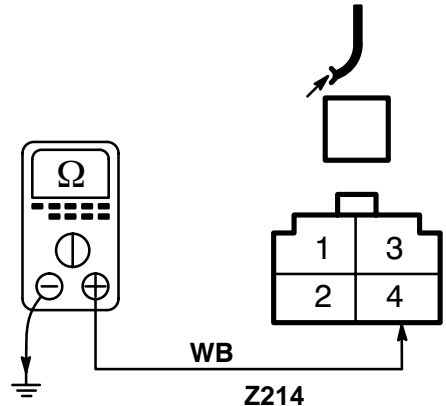

**Z214**  
Front Blower Re-  
sistor Unit



**PROBLEM CAUSE**  
- WB Wire

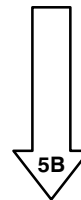

5B
R040022

**CONDITIONS**

- Ignition Switch  
*Position: II*
- Front Fan Speed Switch  
*Position: I*

**RESULTS**

- Front Blower Motor  
*Operates*

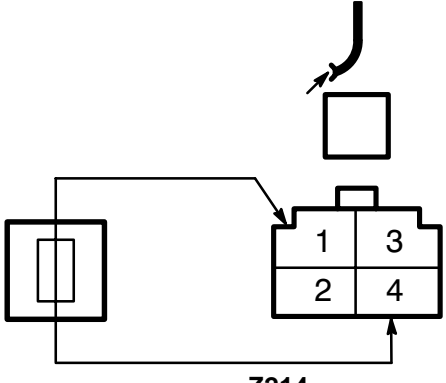

**Z214**  
Front Blower Re-  
sistor Unit



**PROBLEM CAUSE**  
- BO Wire  
- Front Blower  
Motor



**PROBLEM CAUSE**  
- Front Blower Resistor Unit

Test C

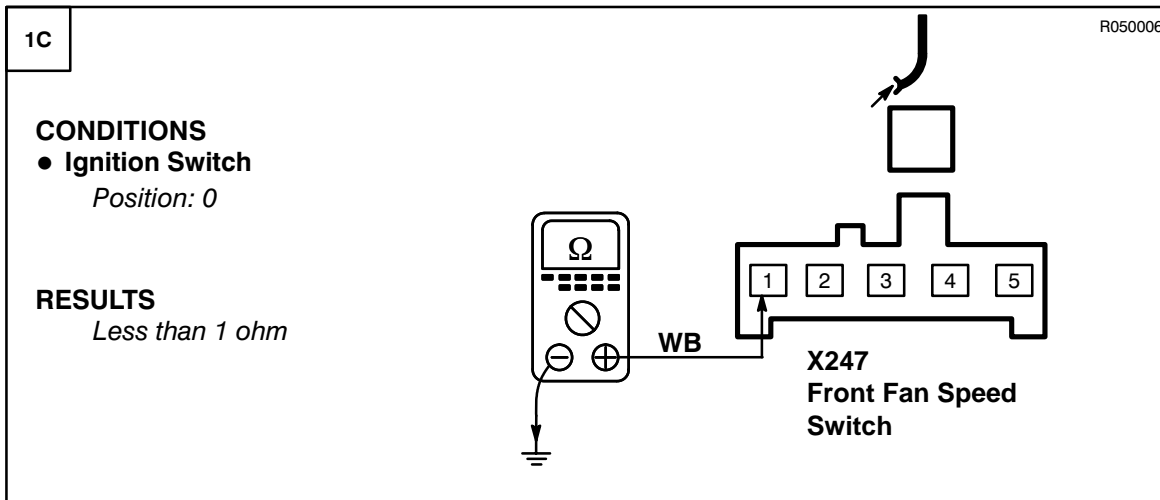

**PROBLEM CAUSE**

- WB Wire
- B Wire

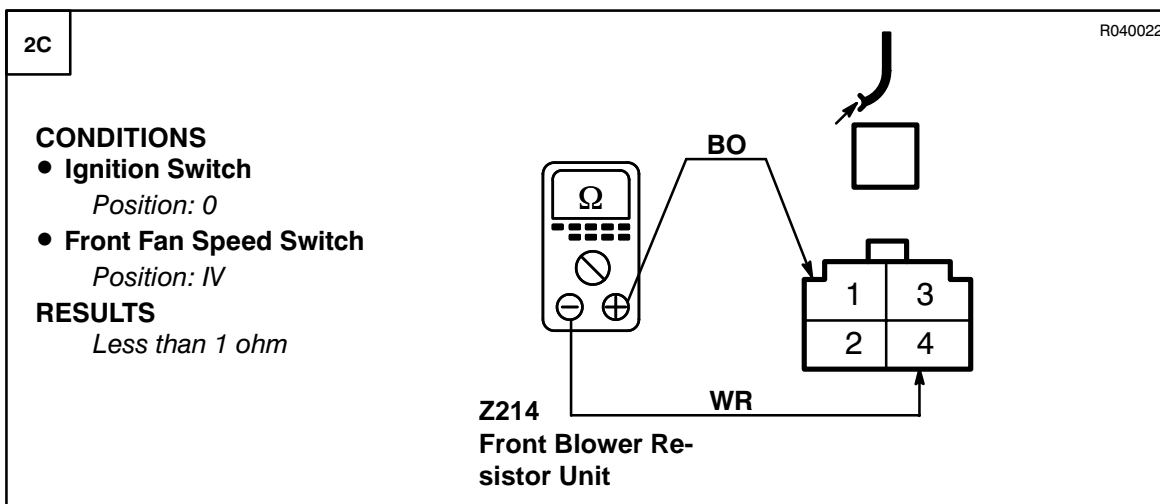

**PROBLEM CAUSE**

- BO Wire
- WB Wire
- Front Fan Speed Switch

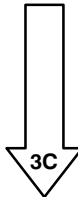

3C
2C
R040022

**CONDITIONS**

- Ignition Switch  
*Position: 0*
- Front Fan Speed Switch  
*Position: III*

**RESULTS**  
*Less than 1 ohm*

**Z214**  
Front Blower Resistor Unit



**PROBLEM CAUSE**

- G Wire
- Front Fan Speed Switch

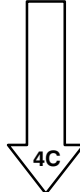

4C
R040022

**CONDITIONS**

- Ignition Switch  
*Position: 0*
- Front Fan Speed Switch  
*Position: II*

**RESULTS**  
*Less than 1 ohm*

**Z214**  
Front Blower Resistor Unit



**PROBLEM CAUSE**

- PU Wire
- Front Fan Speed Switch



**PROBLEM CAUSE**

- Front Blower Resistor Unit

**Test D**

1D

R040029

**CONDITIONS**

- Ignition Switch  
*Position: II*

**RESULTS**  
*BAT VOLT*

~~OK~~ **PROBLEM CAUSE**

- UR Wire
- YB Wire
- Air Recirculation Solenoid In-Line Fuse

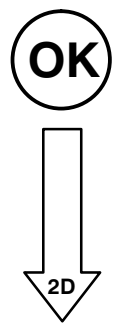

2D

R050002.00

**CONDITIONS**

- Ignition Switch  
*Position: 0*

**RESULTS**  
*Less than 1 ohm*

~~OK~~ **PROBLEM CAUSE**

- WB Wire
- B Wire

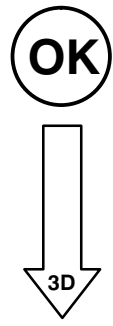

3D
2D
R040029

**CONDITIONS**

- Ignition Switch  
*Position: 0*
- Air Supply Selector Switch  
*Fresh Air Mode*

**RESULTS**  
*Less than 1 ohm*

**UB**

**K123**  
**Air Recirculation Solenoid**



- PROBLEM CAUSE**
- UB Wire
  - Air Supply Selector Switch

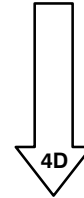

4D
4D
R040029

**CONDITIONS**

- Ignition Switch  
*Position: 0*
- Air Supply Selector Switch  
*Recirculation Mode*

**RESULTS**  
*Less than 1 ohm*

**RG**

**K123**  
**Air Recirculation Solenoid**



- PROBLEM CAUSE**
- RG Wire
  - Air Supply Selector Switch
  - Air Supply Selector Diode



- PROBLEM CAUSE**
- Air Recirculation Solenoid

**Test E**

R050006

1E

**CONDITIONS**

- Ignition Switch  
*Position: 0*

**RESULTS**  
*Less than 1 ohm*

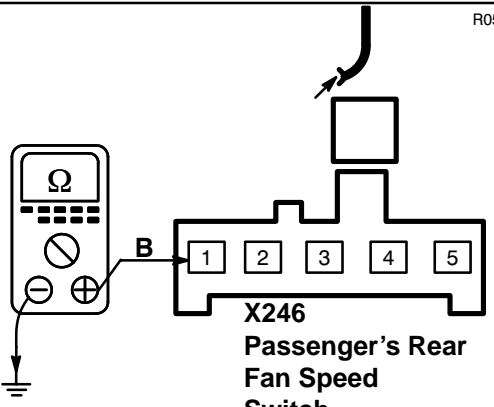

**X246**  
Passenger's Rear Fan Speed Switch

~~OK~~ **PROBLEM CAUSE**  
- B Wire

**OK**

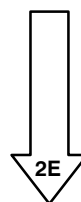

R040028

2E

**CONDITIONS**

- Ignition Switch  
*Position: 0*
- Passenger's Rear Fan Speed Switch  
*Position: I*  
*Position: II*  
*Position: III*  
*Position: IV*

**RESULTS**  
*Less than 1 ohm*

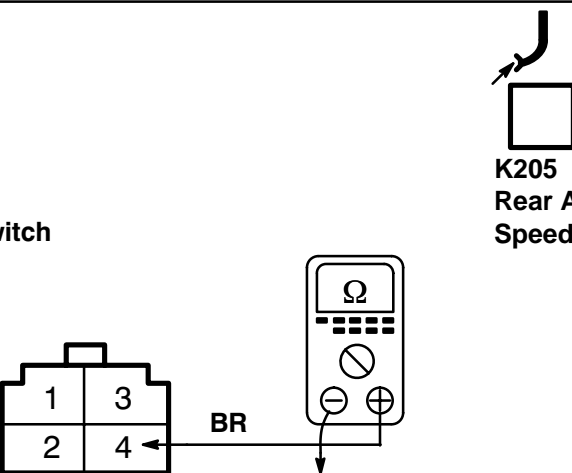

**K205**  
Rear A/C Fan Speed Relay

~~OK~~ **PROBLEM CAUSE**  
- BR Wire  
- Passenger's Rear Fan Speed Switch

**OK**

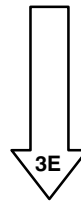

# K1 ETM

## DISCOVERY

2E

3E

R050016

**CONDITIONS**

- Ignition Switch  
*Position: II*

**RESULTS**  
*BAT VOLT*

**K193**  
Rear Blower Motor Relay



**PROBLEM CAUSE**

- YG Wire
- WO Wire
- B Wire

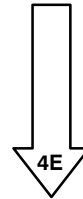

4E

R040022

**CONDITIONS**

- Ignition Switch  
*Position: II*

**RESULTS**  
*BAT VOLT*

**K205**  
Rear A/C Fan Speed Relay



**PROBLEM CAUSE**

- WG Wire

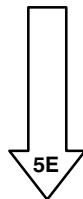

R040022

**4E**

**5E**

**CONDITIONS**

- Ignition Switch  
*Position: II*

**RESULTS**  
*BAT VOLT*

**K194  
Rear A/C Control  
Relay**

~~OK~~ **PROBLEM CAUSE**  
- WG Wire

**OK**

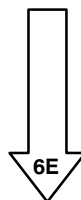

R040022

**6E**

**CONDITIONS**

- Ignition Switch  
*Position: 0*

**RESULTS**  
*Less than 1 ohm*

**K194  
Rear A/C Control  
Relay**

~~OK~~ **PROBLEM CAUSE**  
- B Wire

**OK**

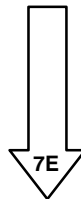



6E
7E
R040022

**CONDITIONS**

- Ignition Switch  
*Position: II*
- Passenger's Rear Fan Speed Switch  
*Position: I*

**RESULTS**

- Rear Blower Motor  
*Operates*

**K194**  
Rear A/C Control Relay

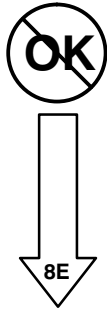

**OK**

**PROBLEM CAUSE**

- G Wire
- Rear A/C Control Relay
- Rear A/C Switch Amplifier

### Test B

8E
8E
R040022

**CONDITIONS**

- Ignition Switch  
*Position: II*
- Passenger's Rear Fan Speed Switch  
*Position: I*
- Rear A/C  
*On*

**RESULTS**

- Rear Blower Motor  
*Operates*

**K205**  
Rear A/C Fan Speed Relay

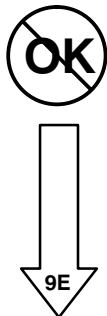

**OK**

**PROBLEM CAUSE**

- S Wire
- Rear A/C Fan Speed Relay

R040022

8E

9E

**CONDITIONS**

- Ignition Switch  
*Position: II*
- Passenger's Rear Fan Speed Switch  
*Position: I*
- Rear A/C  
*On*

**RESULTS**  
*Less than 1 ohm*

PG

K193  
Rear Blower  
Motor Relay

~~OK~~ PROBLEM CAUSE  
- PG Wire

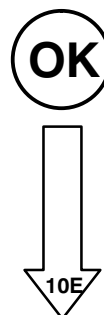

R050016

10E

**CONDITIONS**

- Ignition Switch  
*Position: II*
- Passenger's Rear Fan Speed Switch  
*Position: I*
- Rear A/C  
*On*

**RESULTS**

- Rear Blower Motor  
*Operates*

NR

YG

K193  
Rear Blower  
Motor Relay

~~OK~~ PROBLEM CAUSE  
- NR Wire  
- Rear Blower  
Motor

~~OK~~ PROBLEM CAUSE  
- Rear Blower  
Motor Relay

Test F

R050006

1F

**CONDITIONS**

- Ignition Switch  
*Position: 0*

**RESULTS**  
*Less than 1 ohm*

**X246**  
Passenger's Rear  
Fan Speed  
Switch



**PROBLEM CAUSE**  
- B Wire

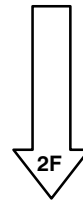

R040022

2F

**CONDITIONS**

- Ignition Switch  
*Position: 0*
- Passenger's Rear Fan Speed Switch  
*Position: IV*

**RESULTS**  
*Less than 1 ohm*

**Z215**  
Rear Blower Re-  
sistor Unit



**PROBLEM CAUSE**  
- B Wire  
- G Wire  
- Passenger's Rear  
Fan Speed  
Switch

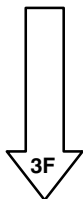

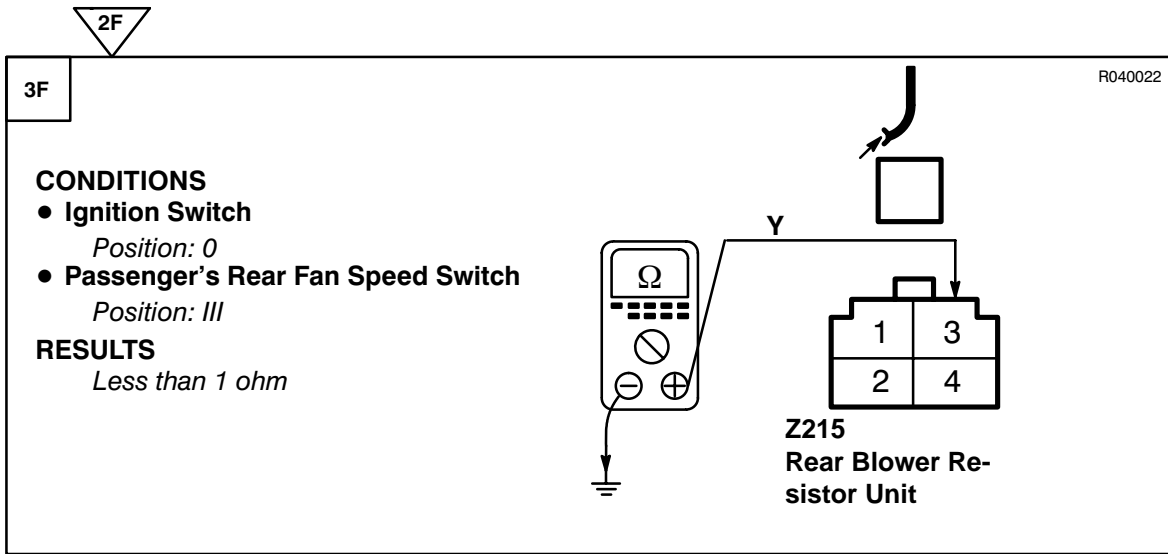

**PROBLEM CAUSE**

- Y Wire
- Passenger's Rear Fan Speed Switch

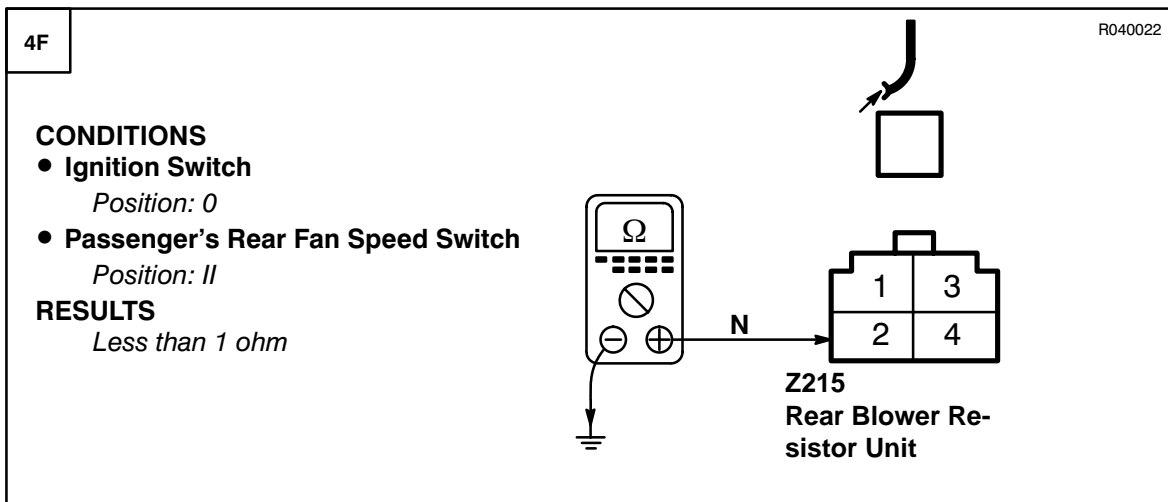
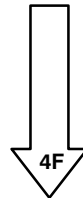

**PROBLEM CAUSE**

- N Wire
- Passenger's Rear Fan Speed Switch



**PROBLEM CAUSE**

- Rear Blower Resistor Unit

**CIRCUIT OPERATION****Compressor Control (MFI–V8) (300Tdi with EDC)**

With the Ignition Switch (X134) in position II, battery voltage is applied to the Ignition Load Relay (K127). The relay is energized, applying battery voltage to the Compressor Clutch Relay (K108) and the A/C Logic Relay (K170). When the Front Fan Speed Switch (X247) is turned to positions I, II, III, or IV and the Front A/C Switch (X225) is turned On, ground is provided to terminal 86 of the A/C Logic Relay (K170) through the closed contacts of the A/C Dual Pressure Switch (X102) and the Front A/C Evaporator Temperature Switch (X101).

The relay is energized, applying battery voltage to the Engine Control Module (ECM) (Z132), signalling the ECM that compressor operation has been requested. The ECM then provides ground to the coil of the Compressor Clutch Relay (K108). The relay is energized, applying battery voltage to the Compressor Clutch (K107). Compressor Clutch operation is now controlled by the status of the A/C Dual Pressure Switch (X102) and the Front A/C Evaporator Temperature Switch (X101).

The Front A/C Evaporator Temperature Switch (X101) is fitted in the airflow out of the front evaporator to sense the temperature of the exterior fins. Should ice begin to form, due to low temperature, the switch will open. The A/C Dual Pressure Switch (X102) monitors refrigerant pressure in the high pressure line, should pressure become too high or too low the switch will open. When one or both of these switches open the ground supply to terminal 86 of the A/C Logic Relay (K170) will be interrupted. The relay de-energizes, removing battery voltage from the Engine Control Module (ECM) (Z132), signalling the ECM that compressor operation should be turned off. The ECM removes the ground supply to the coil of the Compressor Clutch Relay (K108). The relay then de-energizes, removing battery voltage from the Compressor Clutch (K107), disengaging the Compressor.

**Compressor Control (MFI–T16)**

With the Ignition Switch (X134) in position II, battery voltage is applied to the Compressor Clutch Relay (K108) and the A/C Logic Relay (K170). When the Front Fan Speed Switch (X247) is turned

to positions I, II, III, or IV and the Front A/C Switch (X225) is turned On, ground is provided to terminal 85 of the A/C Logic Relay (K170) through the closed contacts of the A/C Dual Pressure Switch (X102) and the Front A/C Evaporator Temperature Switch (X101).

The relay is energized, applying ground to terminal 35 of the Engine Control Module (ECM) (Z132), signalling the ECM that compressor operation has been requested. The ECM then provides ground to the terminal 86 of the Compressor Clutch Relay (K108). The relay is energized, applying battery voltage to the Compressor Clutch (K107). Compressor Clutch operation is now controlled by the status of the A/C Dual Pressure Switch (X102) and the Front A/C Evaporator Temperature Switch (X101).

The Front A/C Evaporator Temperature Switch (X101) is fitted in the airflow out of the front evaporator to sense the temperature of the exterior fins. Should ice begin to form, due to low temperature, the switch will open. The A/C Dual Pressure Switch (X102) monitors refrigerant pressure in the high pressure line, should pressure become too high or too low the switch will open. When one or both of these switches open, the ground supply to terminal 85 of the A/C Logic Relay (K170) will be interrupted. The relay de-energizes, removing the ground supply from terminal 35 of the Engine Control Module (ECM) (Z132), signalling the ECM that compressor operation should be turned off. The ECM removes the ground supply to terminal 86 of the Compressor Clutch Relay (K108). The relay then de-energizes, removing battery voltage from the Compressor Clutch (K107), disengaging the Compressor.

**Compressor Control (300Tdi without EDC)**

With the Ignition Switch (X134) in position II, battery voltage is applied to the Ignition Load Relay (K127). The relay is energized, applying battery voltage to the Compressor Clutch Relay (K108). When the Front Fan Speed Switch (X247) is turned to positions I, II, III, or IV and the Front A/C Switch (X225) is turned On, ground is provided to terminal 86 of the Compressor Clutch Relay (K108) through the closed contacts of the A/C Dual Pressure Switch (X102), the Front A/C Evaporator Temperature Switch (X101), and the Compressor Clutch Cut-out Switch (X259).

The relay is energized, applying battery voltage to the Compressor Clutch (K107). Compressor Clutch operation is now controlled by the status of the A/C Dual Pressure Switch (X102), the Front A/C Evaporator Temperature Switch (X101), and the Compressor Clutch Cut-out Switch (X259).

The Front A/C Evaporator Temperature Switch (X101) is fitted in the airflow out of the front evaporator to sense the temperature of the exterior fins. Should ice begin to form, due to low temperature, the switch will open. The A/C Dual Pressure Switch (X102) monitors refrigerant pressure in the high pressure line, should pressure become too high or too low the switch will open. When one or more of these switches open, the ground supply to terminal 86 of the Compressor Clutch Relay (K108) will be interrupted. The relay de-energizes, removing battery voltage from the Compressor Clutch (K107), disengaging the Compressor.

**Rear A/C Refrigerant Control Valve**

When front A/C has been selected and the Compressor Clutch (K107) is engaged, the Compressor Clutch Relay (K108) is energized and voltage is applied on the BG wires to the Rear A/C Refrigerant Control Valve (K207). When rear A/C is selected a ground signal is applied to the Rear A/C Switch Amplifier (Z216). The Rear A/C Switch Amplifier (Z216) then applies a ground signal to energise the Rear A/C Control Relay (K194) and the Rear A/C Fan Speed Relay (K205). When the Passenger's Rear Fan Speed Switch (X246) is in any position other than Off, ground is applied to the Rear A/C Refrigerant Control Valve (K207) through the closed contacts of the Passengers Rear Fan Speed Switch (X246), BR wire, closed contacts of the Rear A/C Fan Speed Relay (K205), PG wire, UB wire, Rear A/C Refrigerant Control Valve Diode

(Z228), P wire, closed contacts of the Rear A/C Evaporator Temperature Switch (X260), and the RG wire.

The Rear A/C Evaporator Temperature Switch (X260) senses the temperature of the exterior fins. Should ice begin to form due to low temperature, the switch will open and the ground supply to the Rear A/C Refrigerant Control Valve (K207) will then be interrupted. The valve de-energises and refrigerant flow is interrupted.

The Rear A/C Refrigerant Control Valve (K207) will also be de-energised if one or more of the following conditions occurs:

1. The Front A/C Switch (X225) has been turned OFF.
2. The Front Fan Speed Switch (X247) has been turned OFF.
3. The Rear A/C switches have been turned OFF.
4. The Passenger's Rear Fan Speed Switch (X246) has been turned OFF.
5. The ECM determines that compressor clutch operation is no longer required.
6. Compressor Clutch (K107) operation has been disabled by the A/C Dual Pressure Switch (X102) or the Front A/C Evaporator Temperature Switch (X101).
7. Compressor Clutch (K107) operation has been disabled by the Compressor Clutch Cut-Out Switch (X259) (300Tdi Without EDC Only).

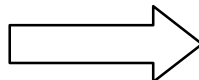
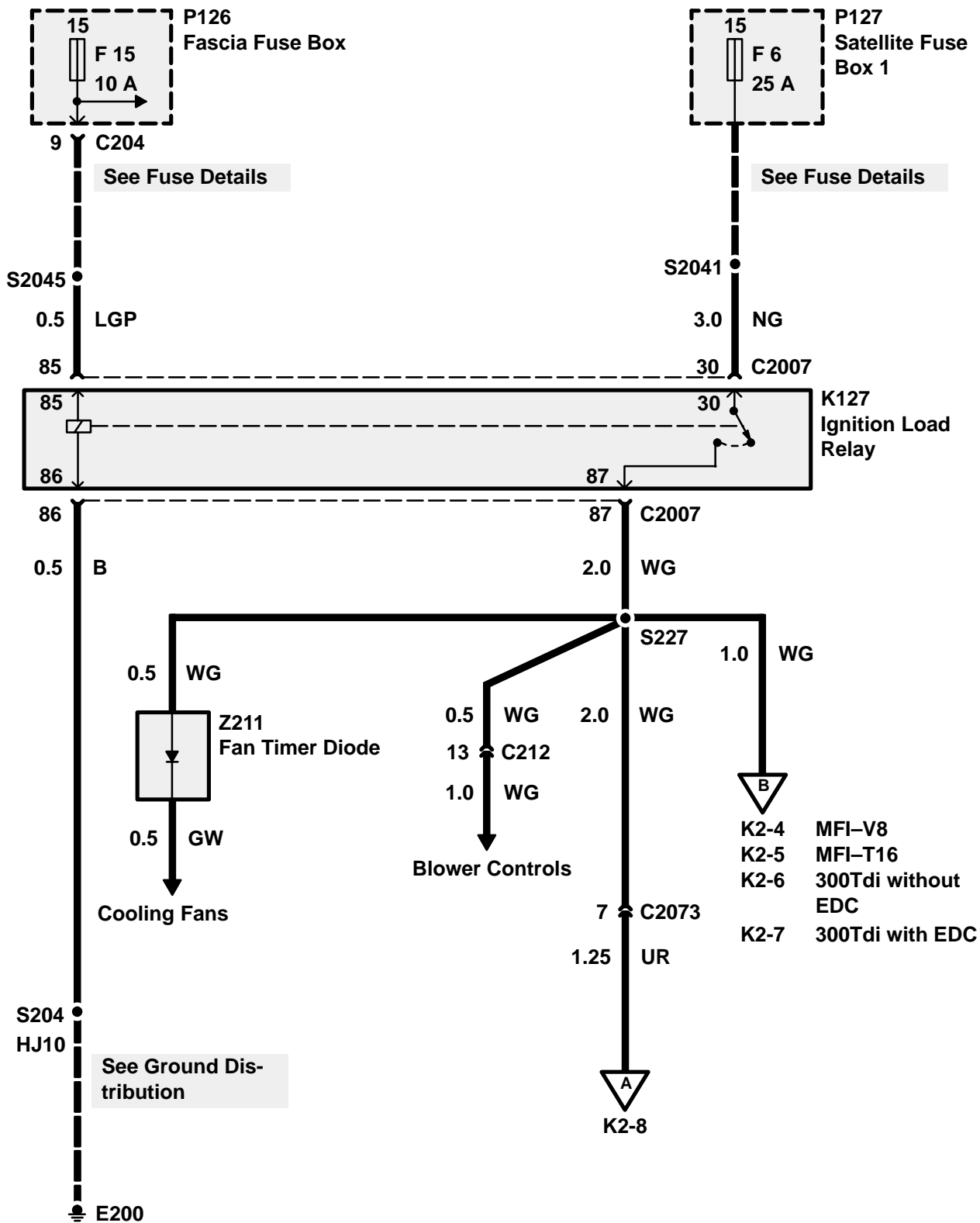

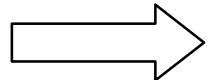
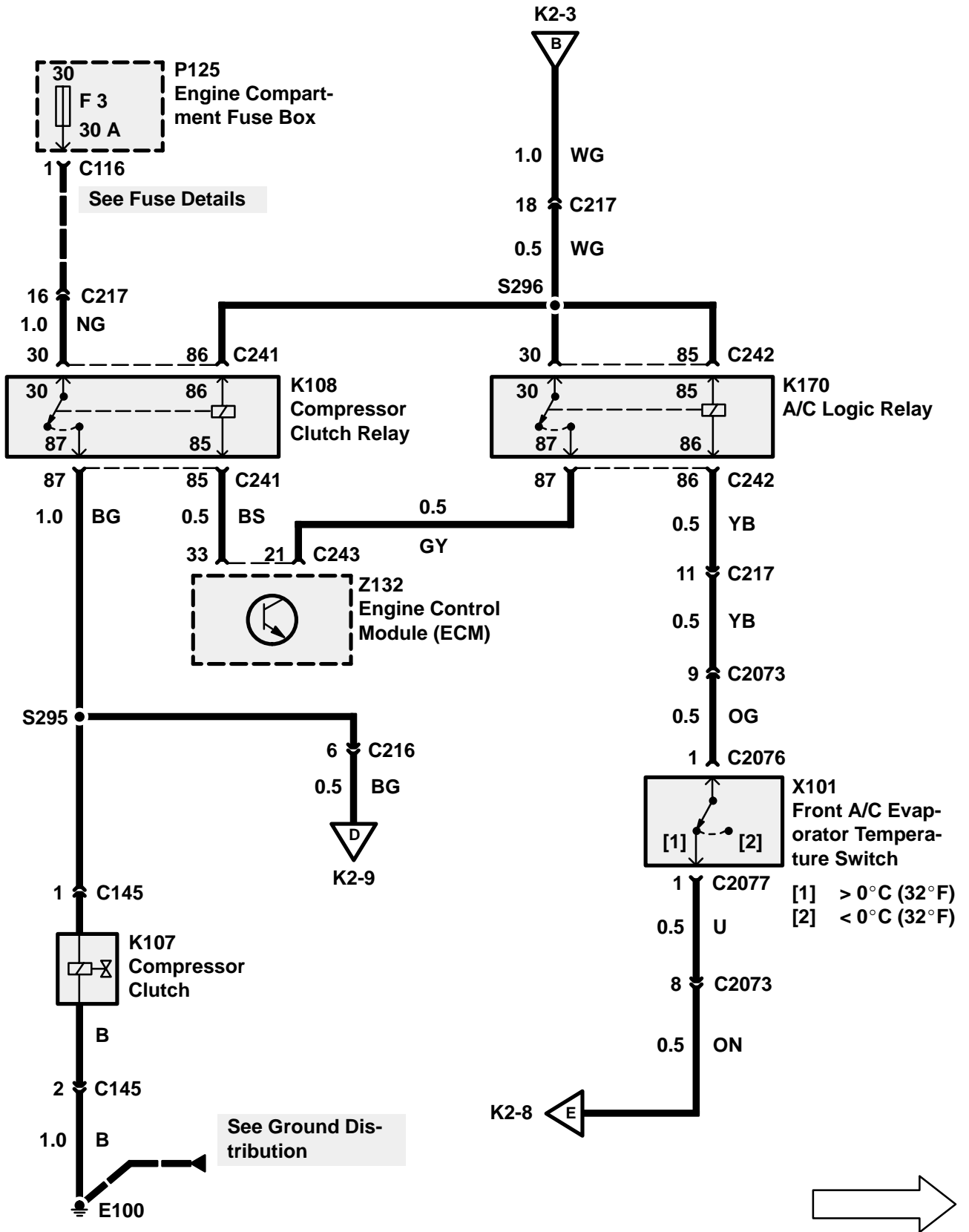



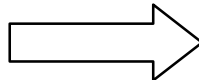
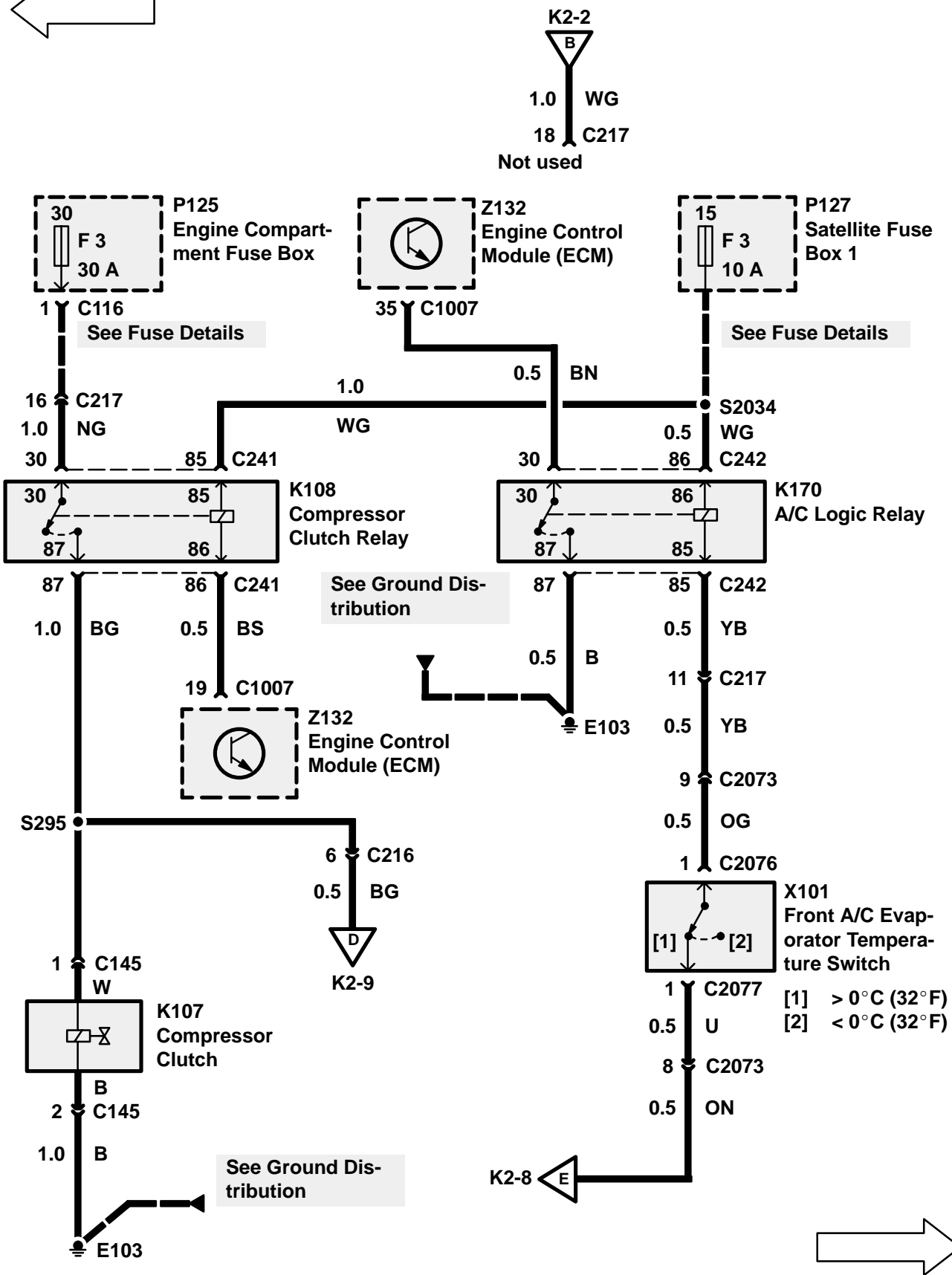
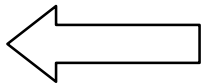





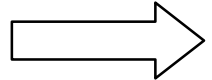
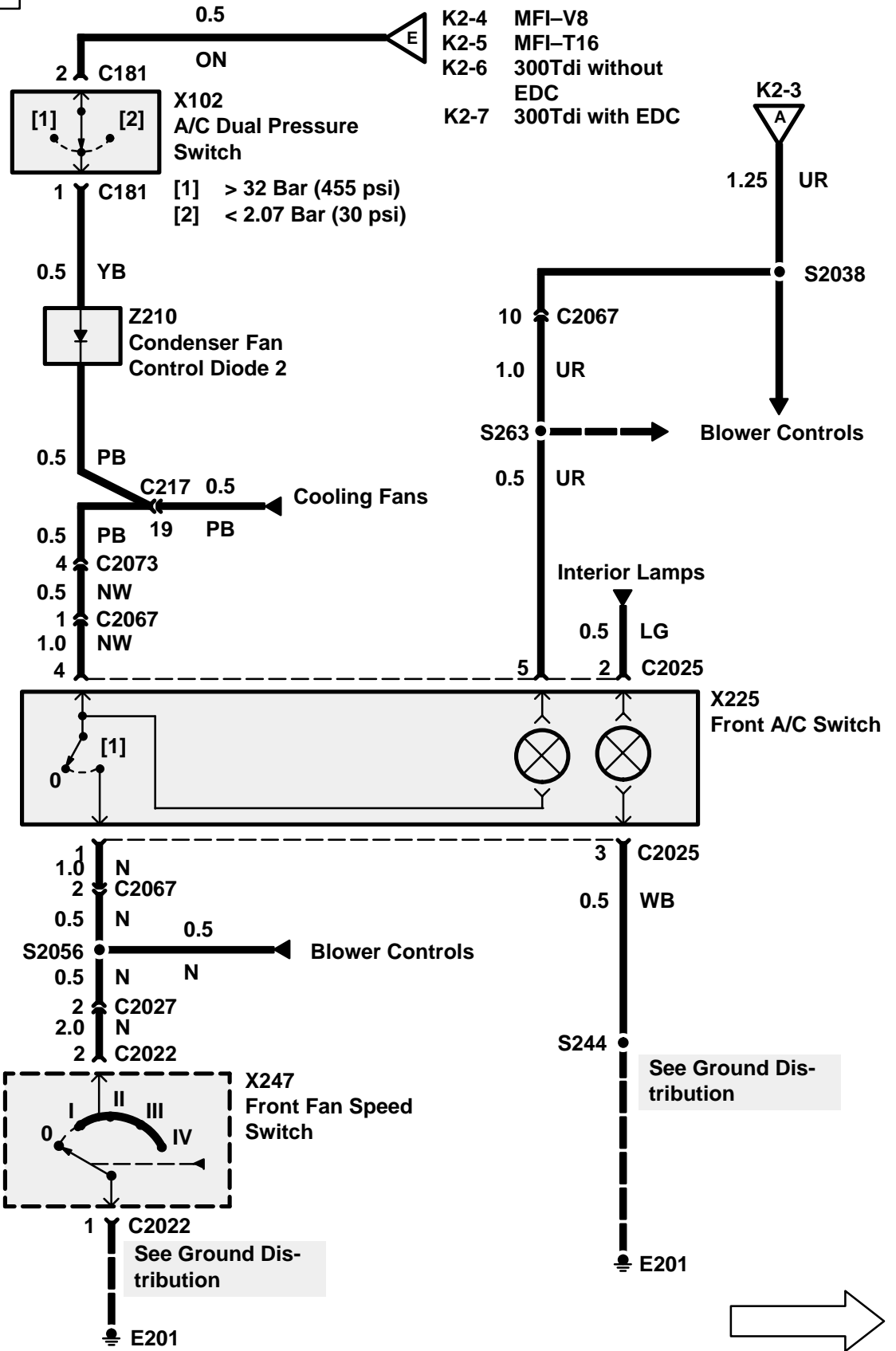
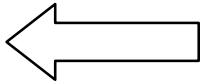

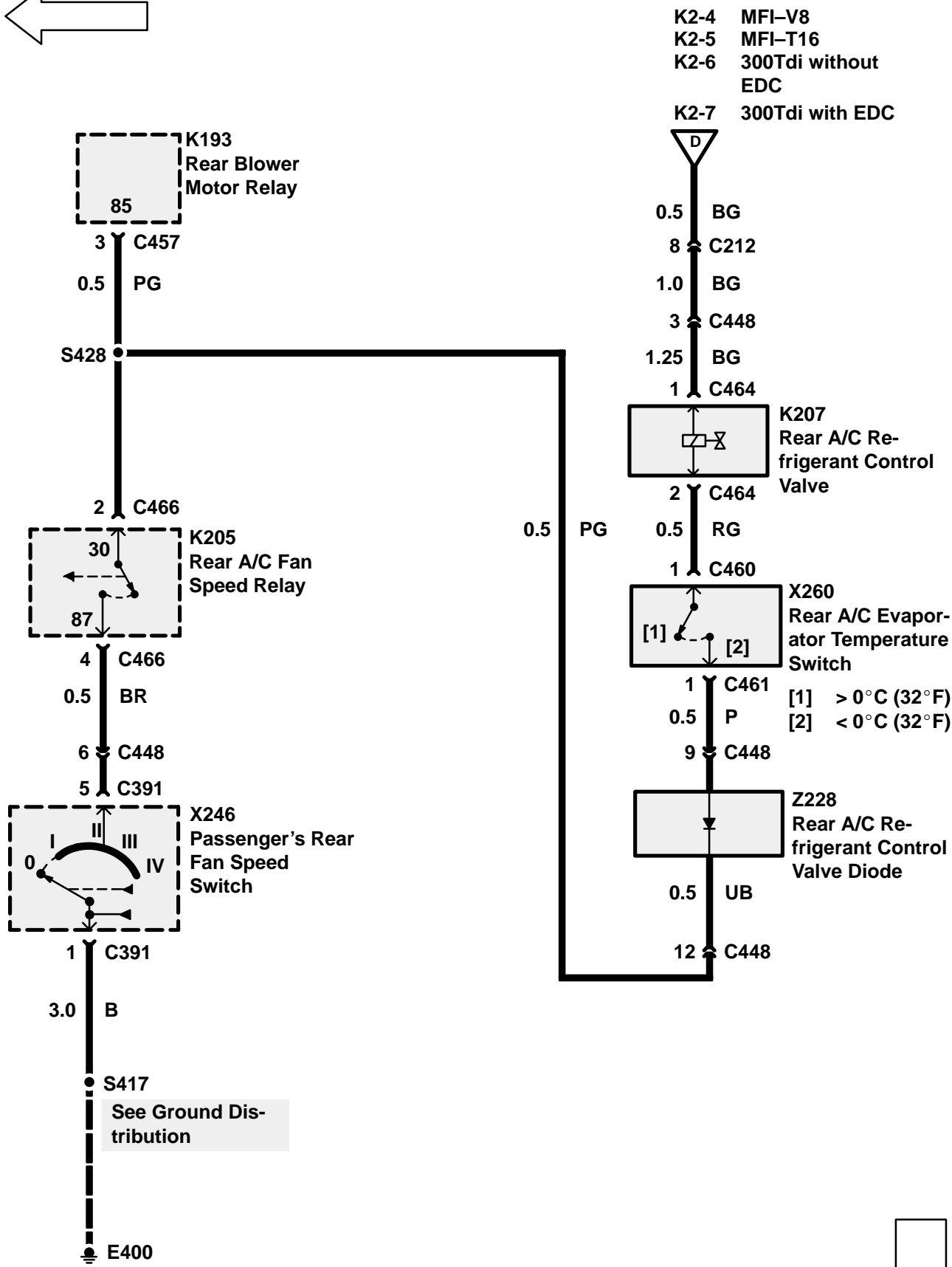
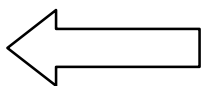

- K2-4 MFI-V8
- K2-5 MFI-T16
- K2-6 300Tdi without EDC
- K2-7 300Tdi with EDC

**TROUBLESHOOTING HINTS**

9. If the Front Blower Motor(s) do not operate normally, refer to Blower Controls, Section K1.
10. Check Fuse F3 of the Engine Compartment Fuse Box (P125), F3 of the Satellite Fuse Box 1, and Fuse F15 of the Fascia Fuse Box (P126).
11. Verify that refrigerant pressure is OK before preceeding with the following diagnostic text.

**SYSTEM DIAGNOSIS (MFI-V8)**

1. If the A/C Compressor Clutch (K107) does not engage in any mode, do Test A.
2. If the Compressor Clutch (K107) remains engaged with the A/C off, do Test F.

**SYSTEM DIAGNOSIS (MFI-T16)**

1. If the A/C Compressor Clutch (K107) does not engage in any mode, do Test B.
2. If the Compressor Clutch (K107) remains engaged with the A/C off, do Test G.

**SYSTEM DIAGNOSIS (300TDI WITHOUT EDC)**

1. If the A/C Compressor Clutch (K107) does not engage in any mode, do Test C.
2. If the Compressor Clutch (K107) remains engaged with the A/C off, do Test H.

**SYSTEM DIAGNOSIS (300TDI WITH EDC)**

1. If the A/C Compressor Clutch (K107) does not engage in any mode, do Test D.
2. If the Compressor Clutch (K107) remains engaged with the A/C off, do Test I.

Test A

**1A MFI-V8** R050001

**CONDITIONS**

- Ignition Switch  
*Position: 0*

**RESULTS**  
*BAT VOLT*

**K108  
Compressor  
Clutch Relay**



**PROBLEM CAUSE**

- F3 Fuse
- NG Wire

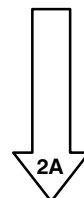

**2A** R050001

**CONDITIONS**

- Ignition Switch  
*Position: II*

**RESULTS**  
*BAT VOLT*

**K108  
Compressor  
Clutch Relay**



**PROBLEM CAUSE**

- WG Wire

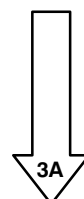

2A
R050001

**3A**

**CONDITIONS**

- Ignition Switch  
*Position: II*

**RESULTS**

- Compressor Clutch  
*Operates*

**K108  
Compressor  
Clutch Relay**



**PROBLEM CAUSE**

- BG Wire
- B Wire
- Compressor Clutch

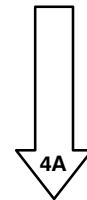

4A
R050001

**CONDITIONS**

- Ignition Switch  
*Position: II*
- Engine  
*On*
- Front Fan Speed Switch  
*Position: I*
- Front A/C Switch  
*On*

**RESULTS**

*BAT VOLT*

**K108  
Compressor  
Clutch Relay**

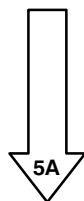

**PROBLEM CAUSE**

- Compressor Clutch Relay



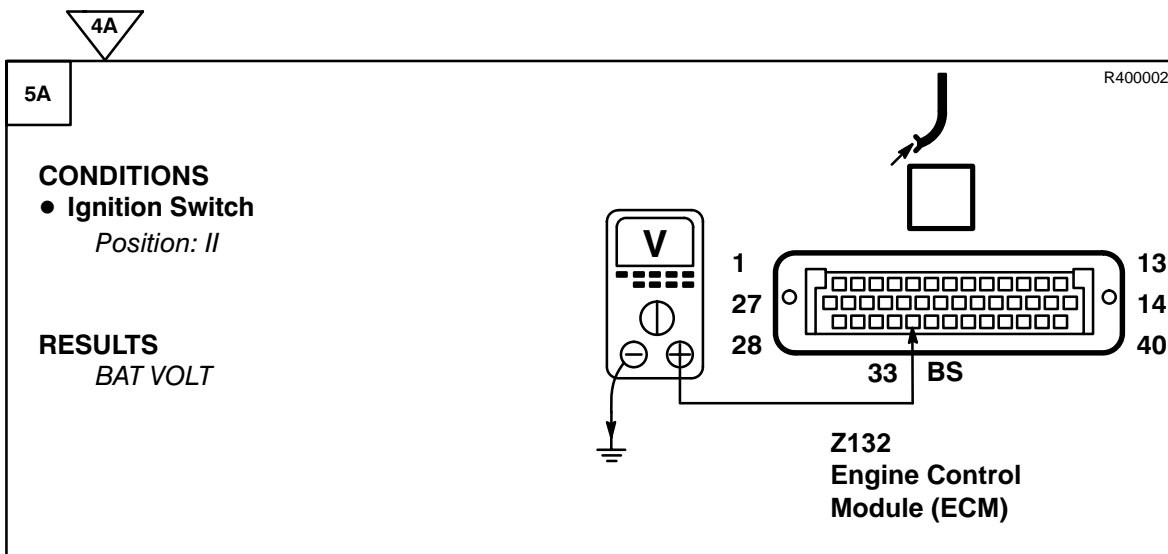

~~OK~~ PROBLEM CAUSE  
- BS Wire

OK

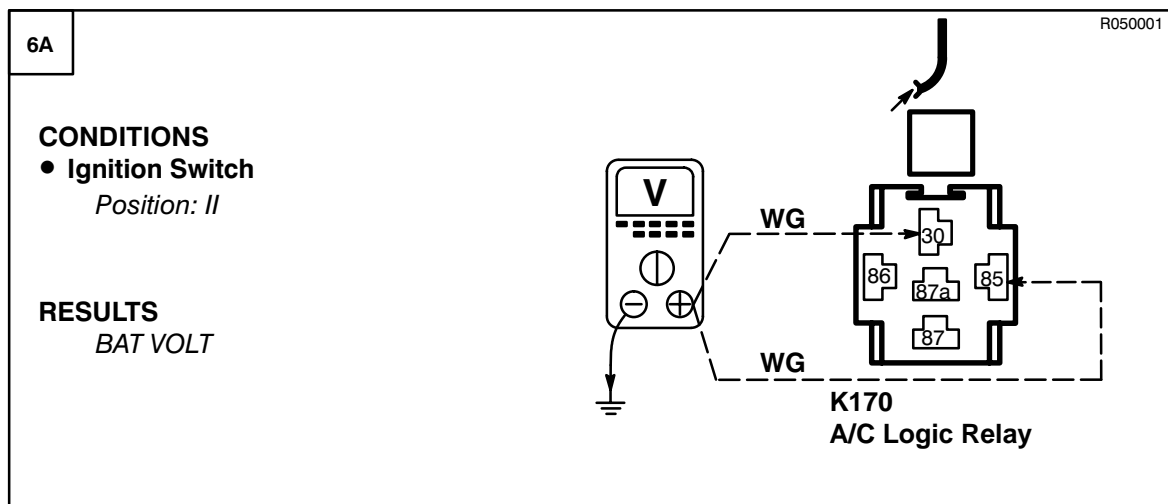
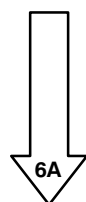

~~OK~~ PROBLEM CAUSE  
- WG Wire

OK

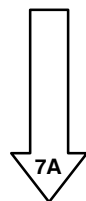

7A
6A
R050001

**CONDITIONS**

- Ignition Switch  
*Position: II*
- Engine  
*On*

**RESULTS**

- Compressor Clutch  
*Operates*

**K170  
A/C Logic Relay**



**PROBLEM CAUSE**

- GY Wire
- Engine Control Module (ECM)

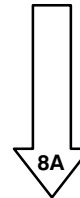

8A
R050001

**CONDITIONS**

- Ignition Switch  
*Position: II*
- Engine  
*On*

**RESULTS**

- Compressor Clutch  
*Operates*

**K170  
A/C Logic Relay**



**PROBLEM CAUSE**

- A/C Logic Relay

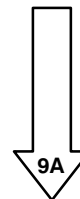

8A

9A

R010002

**CONDITIONS**

- Ignition Switch  
*Position: II*
- Engine  
*On*
- Front Fan Speed Switch  
*Position: I*
- Front A/C Switch  
*On*

**RESULTS**  
*Less than 2 ohms*

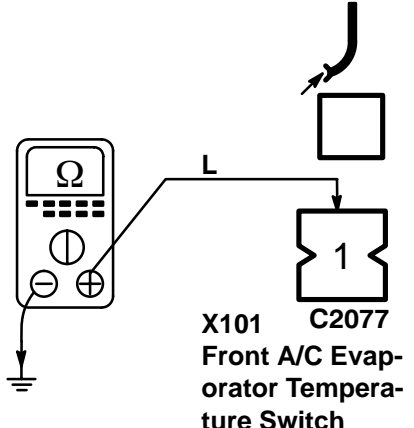

**X101 C2077**  
**Front A/C Evaporator Temperature Switch**



GO TO TEST E



**PROBLEM CAUSE**

- YB Wire
- G Wire
- Front A/C Evaporator Temperature Switch

**Test B**

1B

R050001

**MFI-T16**

**CONDITIONS**

- Ignition Switch  
*Position: 0*

**RESULTS**  
*BAT VOLT*

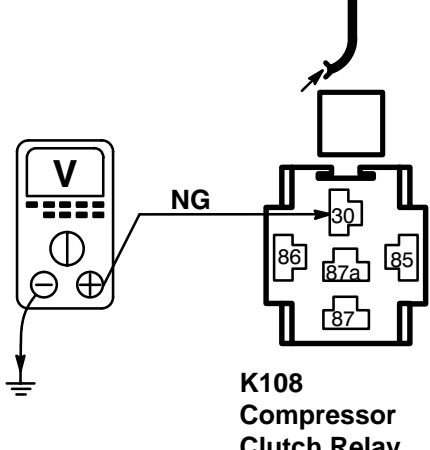

**K108**  
**Compressor Clutch Relay**



**PROBLEM CAUSE**

- F3 Fuse
- NG Wire

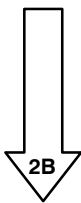

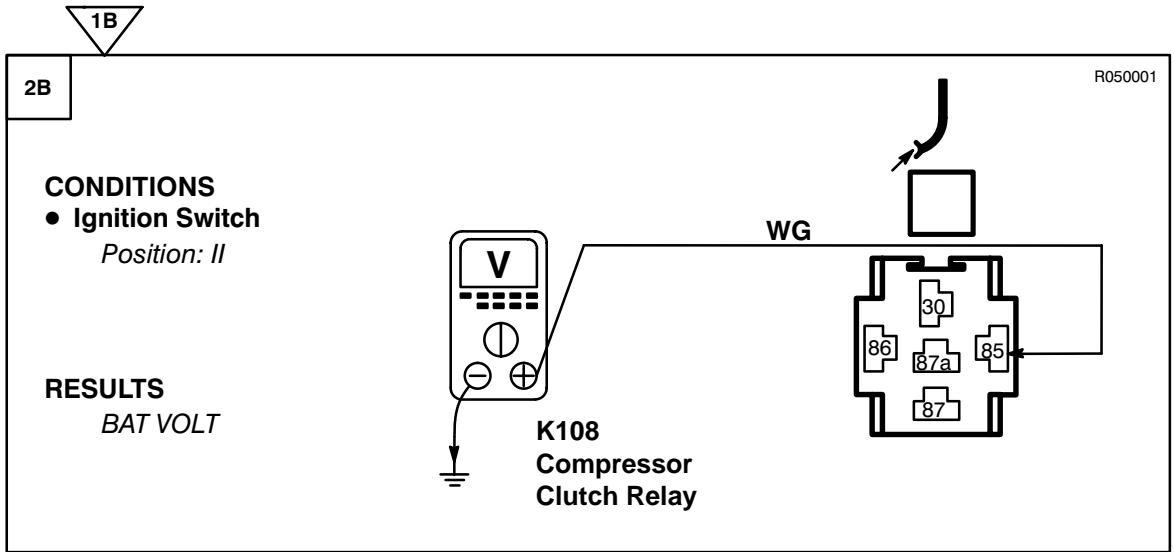

**PROBLEM CAUSE**

- F3 Fuse
- WG Wire

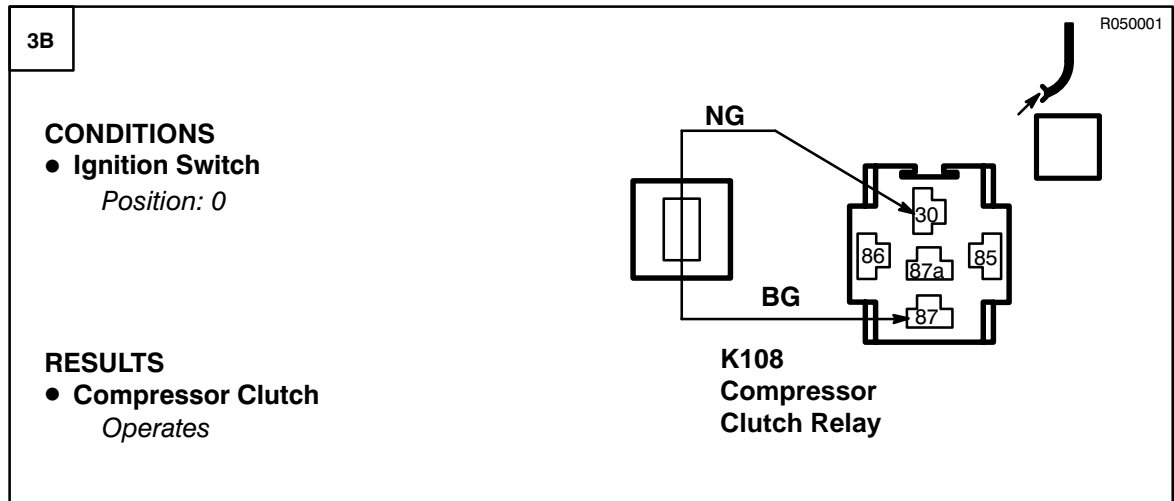
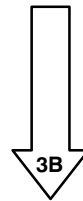

**PROBLEM CAUSE**

- BG Wire
- B Wire
- Compressor Clutch

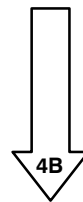

R050001

3B
4B

**CONDITIONS**

- Ignition Switch  
*Position: II*
- Engine  
*On*
- Front Fan Speed Switch  
*Position: I*
- Front A/C Switch  
*On*

**RESULTS**  
*BAT VOLT*

**K108**  
Compressor  
Clutch Relay

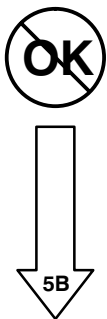

**OK** PROBLEM CAUSE  
- Compressor  
Clutch Relay

R360001

5B

**CONDITIONS**

- Ignition Switch  
*Position: II*

**RESULTS**  
*BAT VOLT*

**Z132**      **C1007**  
Engine Control  
Module (ECM)

**OK** PROBLEM CAUSE  
- BS Wire

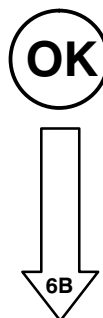

5B
6B
R050001

**CONDITIONS**

- Ignition Switch  
*Position: II*

**RESULTS**

*BAT VOLT*

**K170  
A/C Logic Relay**

OK

**PROBLEM CAUSE**  
 - WG Wire  
 - B Wire  
 - E103

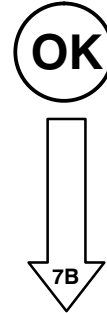

7B
R050001

**CONDITIONS**

- Ignition Switch  
*Position: II*
- Engine  
*On*

**RESULTS**

- Compressor Clutch  
*Operates*

**K170  
A/C Logic Relay**

OK

**PROBLEM CAUSE**  
 - BN Wire  
 - Engine Control  
 Module (ECM)

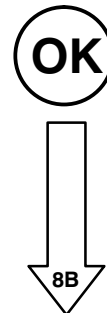

R050001

**7B**

**8B**

**CONDITIONS**

- Ignition Switch  
*Position: II*
- Engine  
*On*

**RESULTS**

- Compressor Clutch  
*Operates*

**K170  
A/C Logic Relay**

**OK** PROBLEM CAUSE  
- A/C Logic Relay

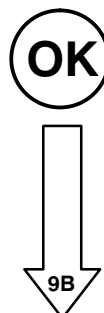

R010002

**9B**

**CONDITIONS**

- Ignition Switch  
*Position: II*
- Engine  
*On*
- Front Fan Speed Switch  
*Position: I*
- Front A/C Switch  
*On*

**RESULTS**

*Less than 2 ohms*

**X101  
Front A/C Evaporator Temperature Switch**

**OK** GO TO TEST E

**OK** PROBLEM CAUSE

- YB Wire
- G Wire
- Front A/C Evaporator Temperature Switch

### Test C

1C

R050001

#### 300Tdi without EDC

**CONDITIONS**

- Ignition Switch  
*Position: 0*

**RESULTS**  
*BAT VOLT*

**K108**  
Compressor  
Clutch Relay



**PROBLEM CAUSE**

- F3 Fuse
- NG Wire

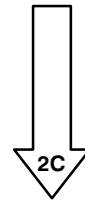

2C

R050001

**CONDITIONS**

- Ignition Switch  
*Position: II*

**RESULTS**  
*BAT VOLT*

**K108**  
Compressor  
Clutch Relay



**PROBLEM CAUSE**

- WG Wire

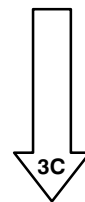



R050001

2C
3C

**CONDITIONS**

- Ignition Switch  
*Position: 0*

**RESULTS**

- Compressor Clutch  
*Operates*

**K108**  
Compressor  
Clutch Relay

**OK** PROBLEM CAUSE

- BG Wire
- B Wire
- Compressor Clutch

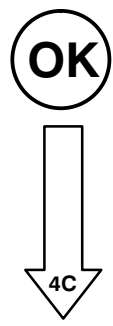

R050001

4C

**CONDITIONS**

- Ignition Switch  
*Position: II*
- Engine  
*On*
- Front Fan Speed Switch  
*Position: I*
- Front A/C Switch  
*On*

**RESULTS**

*BAT VOLT*

**K108**  
Compressor  
Clutch Relay

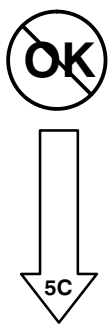

**OK** PROBLEM CAUSE

- Compressor Clutch Relay

4C
5C
R020003

**CONDITIONS**

- Ignition Switch  
*Position: II*
- Engine  
*On*
- Front Fan Speed Switch  
*Position: I*
- Front A/C Switch  
*On*

**RESULTS**  
*Less than 2 ohms*

**X259  
Compressor  
Clutch Cut-out  
Switch**

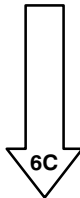

**PROBLEM CAUSE**

- G Wire
- Compressor Clutch Cut-out Switch

6C
R010002

**CONDITIONS**

- Ignition Switch  
*Position: II*
- Engine  
*On*
- Front Fan Speed Switch  
*Position: I*
- Front A/C Switch  
*On*

**RESULTS**  
*Less than 2 ohms*

**X101  
Front A/C Evap-  
orator Tempera-  
ture Switch**



**GO TO TEST E**



**PROBLEM CAUSE**

- YB Wire
- G Wire
- Front A/C Evaporator Temperature Switch

Test D

1D

R050001

**300Tdi with EDC**

**CONDITIONS**

- Ignition Switch  
*Position: 0*

**RESULTS**  
*BAT VOLT*

**K108  
Compressor  
Clutch Relay**



**PROBLEM CAUSE**

- F3 Fuse
- NG Wire

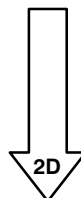

2D

R050001

**CONDITIONS**

- Ignition Switch  
*Position: II*

**RESULTS**  
*BAT VOLT*

**K108  
Compressor  
Clutch Relay**



**PROBLEM CAUSE**

- WG Wire

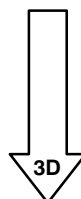

3D
2D
R050001

**CONDITIONS**

- Ignition Switch  
*Position: 0*

**RESULTS**

- Compressor Clutch  
*Operates*

**K108**  
Compressor Clutch Relay



**PROBLEM CAUSE**

- BG Wire
- B Wire
- Compressor Clutch

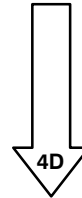

4D
R050001

**CONDITIONS**

- Ignition Switch  
*Position: II*
- Engine  
*On*
- Front Fan Speed Switch  
*Position: I*
- Front A/C Switch  
*On*

**RESULTS**

*BAT VOLT*

**K108**  
Compressor Clutch Relay

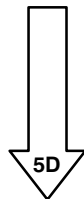

**PROBLEM CAUSE**

- Compressor Clutch Relay

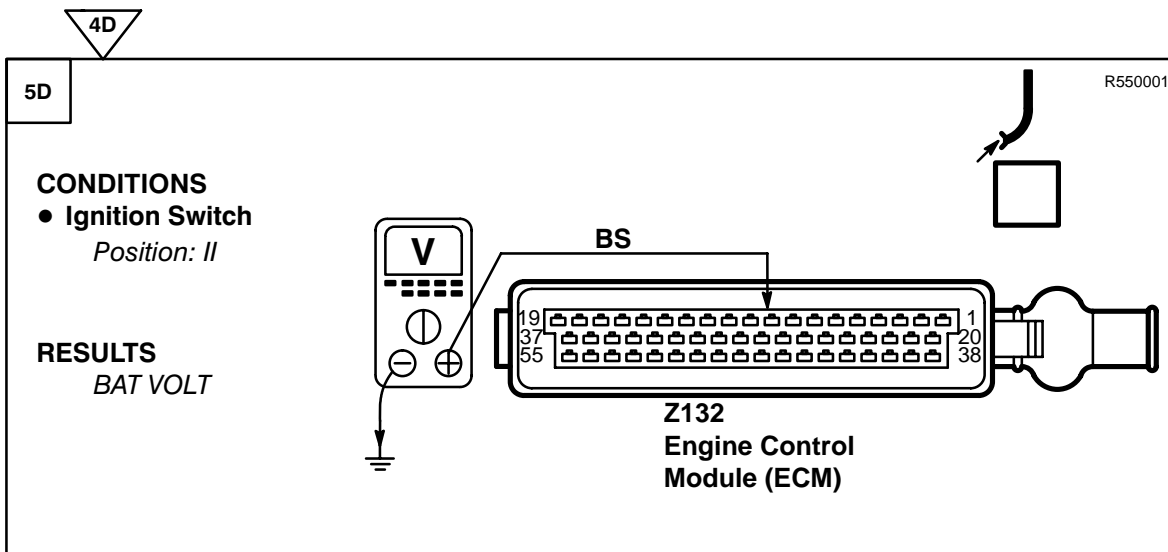

~~OK~~ PROBLEM CAUSE  
- BS Wire

OK

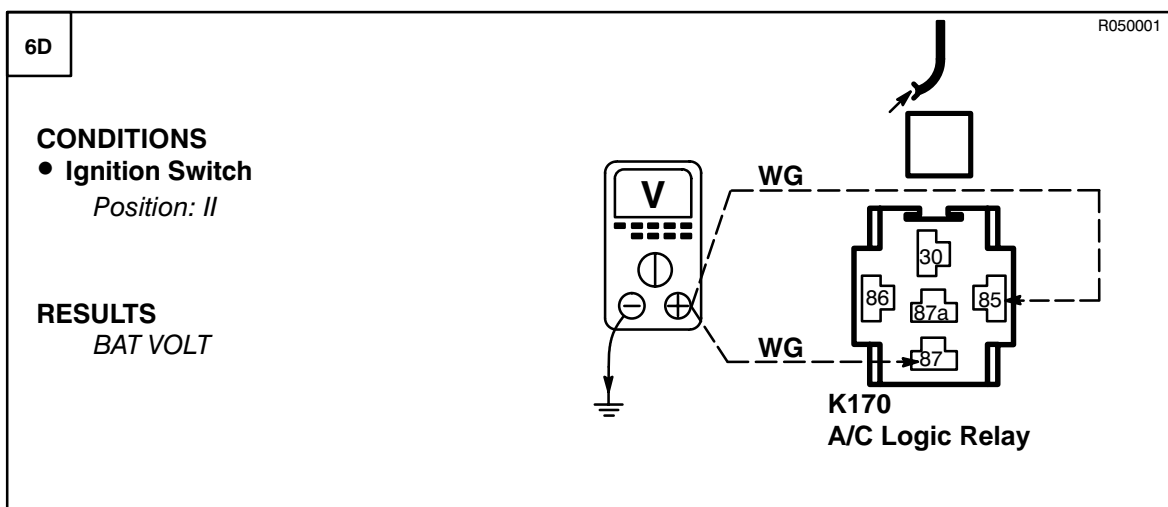
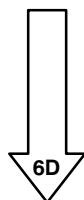

~~OK~~ PROBLEM CAUSE  
- WG Wire

OK

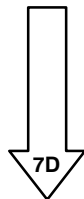

6D
7D
R050001

**CONDITIONS**

- Ignition Switch  
*Position: II*
- Engine  
*On*

**RESULTS**

- Compressor Clutch  
*Operates*

**K170  
A/C Logic Relay**



**PROBLEM CAUSE**

- YG Wire
- Engine Control Module (ECM)

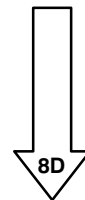

8D
R050001

**CONDITIONS**

- Ignition Switch  
*Position: II*
- Engine  
*On*

**RESULTS**

- Compressor Clutch  
*Operates*

**K170  
A/C Logic Relay**



**PROBLEM CAUSE**

- A/C Logic Relay

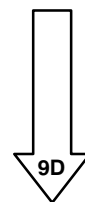

R010002

9D

**9D**

**CONDITIONS**

- Ignition Switch  
*Position: II*
- Engine  
*On*
- Front Fan Speed Switch  
*Position: I*
- Front A/C Switch  
*On*

**RESULTS**  
*Less than 2 ohms*

L

1

**X101**  
Front A/C Evaporator Temperature Switch



GO TO TEST E



**PROBLEM CAUSE**

- YB Wire
- G Wire
- Front A/C Evaporator Temperature Switch

**Test E**

R020027

1E

**1E**

**CONDITIONS**

- Ignition Switch  
*Position: II*
- Engine  
*On*
- Front Fan Speed Switch  
*Position: I*
- Front A/C Switch  
*On*

**RESULTS**  
*Less than 2 ohms*

YB

1 2

**X102**  
A/C Dual Pressure Switch

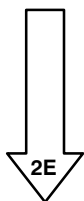

**PROBLEM CAUSE**

- ON Wire
- L Wire
- A/C Dual Pressure Switch

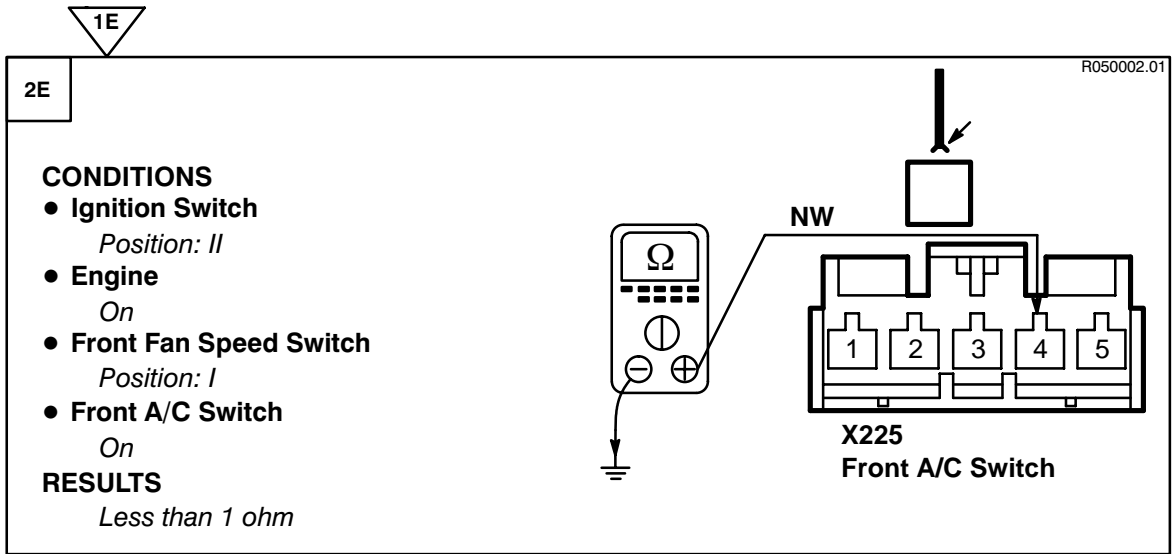

- PROBLEM CAUSE**
- N Wire
  - Front A/C Switch



- PROBLEM CAUSE**
- YB Wire
  - PB Wire
  - NW Wire
  - Condenser Fan Control Diode 2



Test F

1F

**MFI-V8**

R050001

**CONDITIONS**

- Ignition Switch  
*Position: II*
- Front Fan Speed Switch  
*Position: 0*

**RESULTS**  
0V

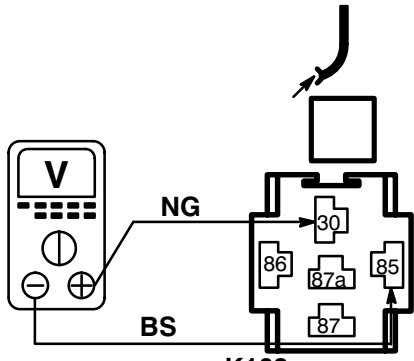

**K108**  
Compressor  
Clutch Relay

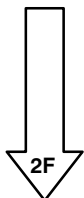

**PROBLEM CAUSE**  
- Compressor  
Clutch Relay

2F

**CONDITIONS**

- Ignition Switch  
*Position: II*
- Front Fan Speed Switch  
*Position: 0*

**RESULTS**  
0V

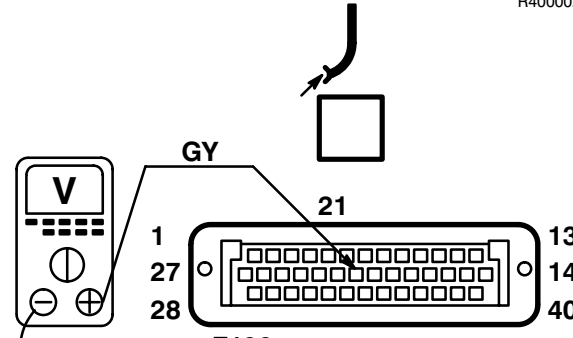

**Z132**  
Engine Control  
Module (ECM)

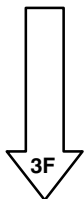

**PROBLEM CAUSE**  
- BS Wire  
- Engine Control  
Module (ECM)

2F

3F

R050001

**CONDITIONS**

- Ignition Switch  
*Position: 0*
- Front Fan Speed Switch  
*Position: 0*

**RESULTS**  
*More than 10K ohms*

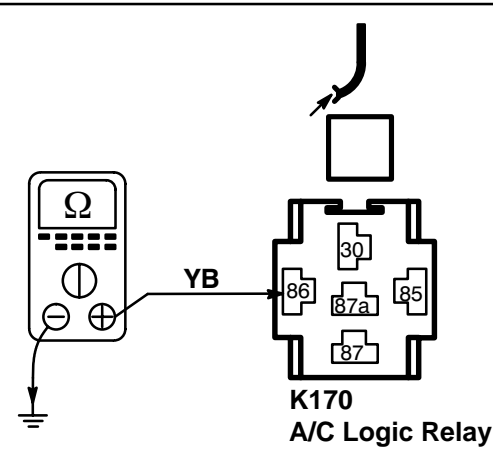

**K170**  
A/C Logic Relay

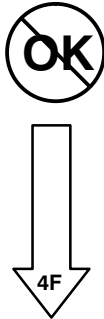

**OK** PROBLEM CAUSE  
- A/C Logic Relay

4F

R010002

**CONDITIONS**

- Ignition Switch  
*Position: 0*
- Front Fan Speed Switch  
*Position: 0*

**RESULTS**  
*More than 10K ohms*

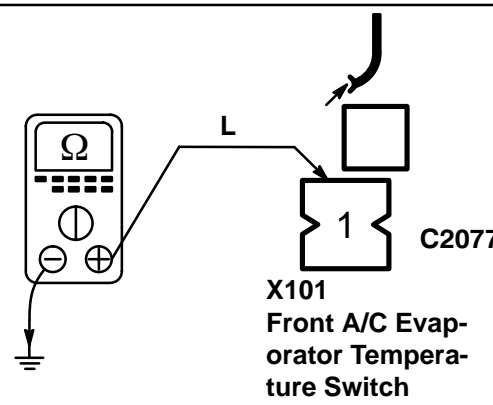

**X101**  
Front A/C Evaporator Temperature Switch  
C2077

**OK** GO TO TEST J

**OK** PROBLEM CAUSE  
- YB Wire  
- G Wire  
- Front A/C Evaporator Temperature Switch

**Test G**

**1G MFI-T16** R050001

**CONDITIONS**

- Ignition Switch  
*Position: II*
- Front Fan Speed Switch  
*Position: 0*

**RESULTS**  
*0V*

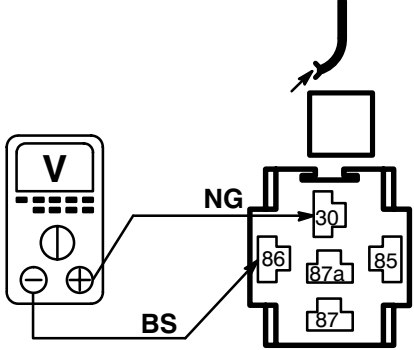

**K108 Compressor Clutch Relay**

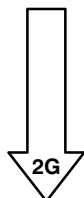

**PROBLEM CAUSE**  
- Compressor Clutch Relay

**2G** R360001

**CONDITIONS**

- Ignition Switch  
*Position: II*
- Front Fan Speed Switch  
*Position: 0*

**RESULTS**  
*More than 10K ohms*

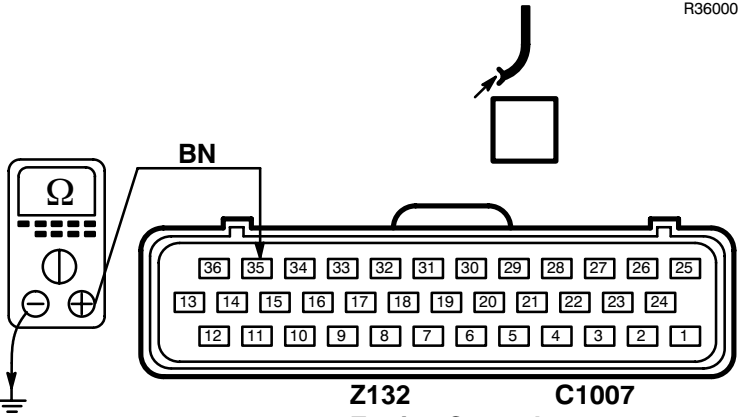

**Z132 Engine Control Module (ECM)**

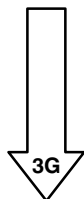

**PROBLEM CAUSE**  
- BS Wire  
- Engine Control Module (ECM)

2G
R050001

**3G**

**CONDITIONS**

- Ignition Switch  
*Position: 0*
- Front Fan Speed Switch  
*Position: 0*

**RESULTS**  
*More than 10K ohms*

**K170  
A/C Logic Relay**

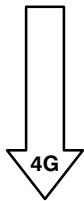

**PROBLEM CAUSE**  
- A/C Logic Relay

4G
R010002

**CONDITIONS**

- Ignition Switch  
*Position: 0*
- Front Fan Speed Switch  
*Position: 0*

**RESULTS**  
*More than 10K ohms*

**X101  
Front A/C Evap-  
orator Tempera-  
ture Switch**



**GO TO TEST J**



**PROBLEM CAUSE**  
- YB Wire  
- G Wire  
- Front A/C Evap-  
orator Tempera-  
ture Switch

**Test H**

**1H 300Tdi without EDC** R050001

**CONDITIONS**

- Ignition Switch  
*Position: II*
- Front Fan Speed Switch  
*Position: 0*

**RESULTS**  
*0V*

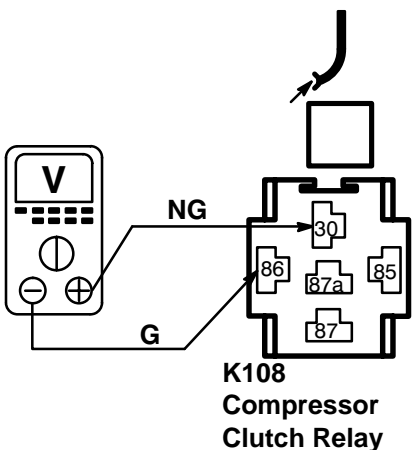

**K108**  
Compressor  
Clutch Relay

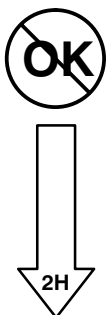

**OK** **PROBLEM CAUSE**  
- Compressor  
Clutch Relay

**2H** R010002

**CONDITIONS**

- Ignition Switch  
*Position: 0*
- Front Fan Speed Switch  
*Position: 0*

**RESULTS**  
*More than 10K ohms*

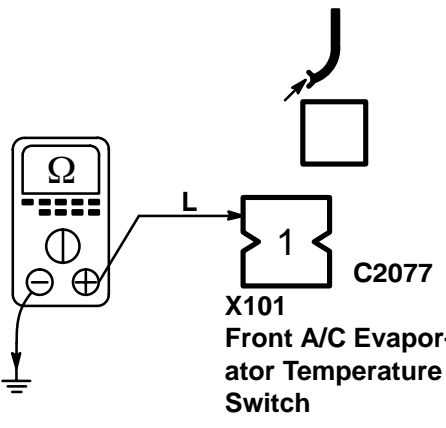

**X101**  
Front A/C Evaporator  
Temperature  
Switch

**OK** **GO TO TEST J**

**OK** **PROBLEM CAUSE**  
- G, YB Wire  
- Compressor Clutch  
Cut-out Switch  
- Front A/C Evaporator  
Temperature Switch

### Test I

11

R050001

### 300Tdi with EDC

**CONDITIONS**

- Ignition Switch  
*Position: II*
- Fan Speed Switch  
*Position: 0*

**RESULTS**  
0V

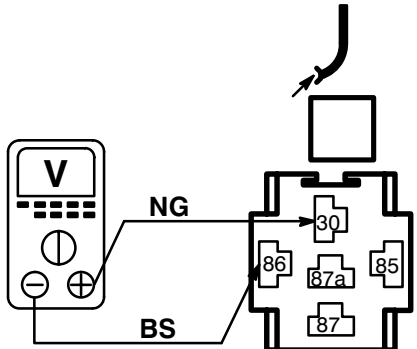

**K108**  
Compressor  
Clutch Relay

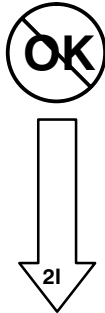

**OK** PROBLEM CAUSE  
- Compressor  
Clutch Relay

21

R550001

**CONDITIONS**

- Ignition Switch  
*Position: II*
- Front Fan Speed Switch  
*Position: 0*

**RESULTS**  
0V

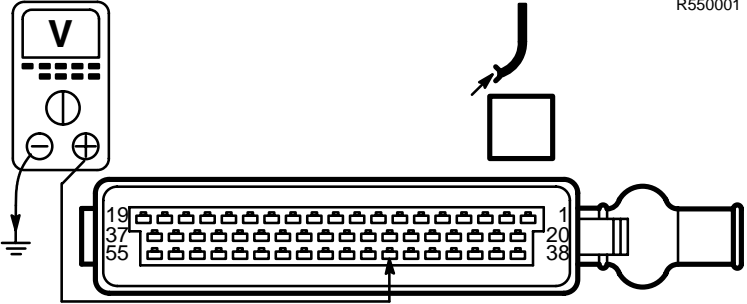

**Z132**  
Engine Control  
Module (ECM)

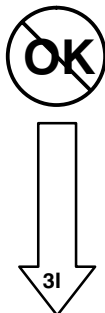

**OK** PROBLEM CAUSE  
- BS Wire  
- Engine Control  
Module (ECM)

R050001

21
31

**CONDITIONS**

- Ignition Switch  
*Position: 0*
- Front Fan Speed Switch  
*Position: 0*

**RESULTS**  
*More than 10K ohms*

**K170**  
A/C Logic Relay

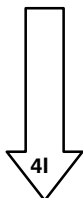

**PROBLEM CAUSE**  
- A/C Logic Relay

R010002

41
41

**CONDITIONS**

- Ignition Switch  
*Position: 0*
- Front Fan Speed Switch  
*Position: 0*

**RESULTS**  
*More than 10K ohms*

**X101**  
Front A/C Evaporator Temperature Switch



GO TO TEST J



**PROBLEM CAUSE**  
- YB Wire  
- G Wire  
- Front A/C Evaporator Temperature Switch

**Test J**

R050002.02

1J

**CONDITIONS**

- Ignition Switch  
*Position: 0*
- Front Fan Speed Switch  
*Position: 0*

**RESULTS**

*More than 10K ohms*

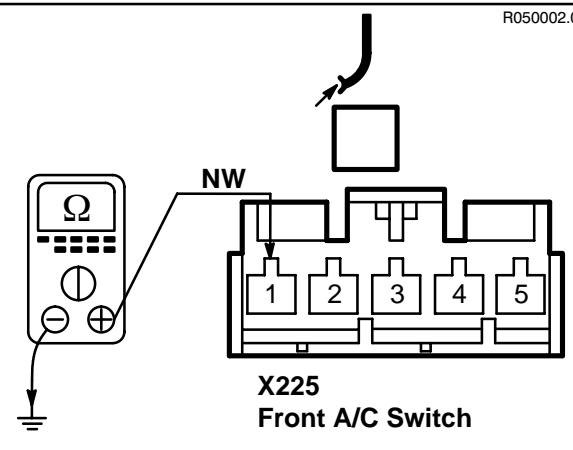

**X225**  
**Front A/C Switch**



- PROBLEM CAUSE**
- N Wire
  - Front Fan Speed Switch



- PROBLEM CAUSE**
- L, NO, YB Wire
  - PB, NW Wire
  - A/C Dual Pressure Switch
  - Front A/C Switch
  - Condenser Fan Control Diode 2



## CIRCUIT OPERATION

### Condenser Fan Operation (MFI-V8)

The Condenser Fans Motors (M113, M121) on vehicles equipped with MFI-V8 engines operate when any of the following conditions occur:

3. Coolant temperature exceeds 100°C (212°F).
4. The air conditioning system is operating.
5. The Engine Control Module (ECM) (Z132) determines that fuel temperature exceeds 70°C and coolant temperature exceeds 110°C after engine shutdown. When this occurs, the fans are turned on for approximately 10 minutes after the engine is shut off.

### Operation with High Coolant Temperature (MFI-V8)

When the Ignition Switch (X134) is in position II, battery voltage is applied to the Ignition Load Relay (K127). The relay is energized, applying battery voltage to the Condenser Fan Relay (K109) and the Fan Control Module (Z118). If the coolant temperature exceeds 100°C (212°F), the Condenser Fan Coolant Temperature Switch (X113) closes and energizes the Condenser Fan Relay (K109) by applying ground to the relay's coil. When the relay is energized, voltage from fuse F3 is applied to the Condenser Fan Motors (M113, M121) through the relay's contacts.

### Fan Operation with A/C (MFI-V8)

With the Ignition Switch (X134) in position II, battery voltage is applied to the Ignition Load Relay (K127). The relay is energized, applying battery voltage to the Condenser Fan Relay (K109). When the Front A/C Switch (X225) is turned on and the Front Fan Speed Switch (X247) is turned to positions I, II, III, or IV, ground is applied to terminal 86 of the Condenser Fan Relay. The relay energizes, applying battery voltage from fuse F3 to the Condenser Fan Motors (M113, M121).

### Operation with the Engine Off (MFI-V8)

The Engine Control Module (Z132) monitors fuel temperature and coolant temperature through sensors. When the ECM determines that fuel temperature is above 70°C and coolant

temperature exceeds 110°C after engine shutdown, the ECM will command fan operation for approximately 10 minutes. The ECM turns on the fans by momentarily grounding the Fan Control Module (Z118) through the BG wire. When the timer unit is grounded, it starts a solid state timer and begins to apply ground from its terminal 9 to the Condenser Fan Relay (K109) through the BP wire. With the Condenser Fan Relay energized, voltage from fuse F3 is applied to the Condenser Fan Motors (M113, M121) through the relay contacts.

### **Cooling Fan and Condenser Fan Operation (MFI-T16)**

The Cooling Fan 1 (M141) or Cooling Fans (M141, M142) and Condenser Fan Motors (M113, M121) on vehicles equipped with MFI-T16 engines operate when any of the following conditions occur:

1. The A/C system is operating.
2. The Engine Control Module (ECM) determines that Cooling Fan and/or Condenser Fan Motor operation is required.

### **Cooling Fan Operation without A/C (MFI-T16)**

With the Ignition Switch (X134) in position II, battery voltage is applied to the Cooling Fan Relay (K190) from fuse F3 of the Satellite Fuse Box 1 (P127). When Cooling Fan Operation is required, the Engine Control Module (ECM) (Z132) grounds terminal 86 of the Cooling Fan Relay (K190). The relay energizes, applying battery voltage from fuse F3 of the Engine Compartment Fuse Box (P125) to the Cooling Fan Motor 1 (M141). When Cooling Fan Operation is no longer required, the ECM removes the ground supply to the Cooling Fan Relay (K190). The Relay de-energizes, removing the voltage supply to the Cooling Fan Motor 1 (M141).

### **Cooling Fan and Condenser Fan Operation with A/C (MFI-T16)**

With the Ignition Switch (X134) in position II, battery voltage is applied to the Ignition Load Relay (K127). The relay is energized, applying battery voltage to the Condenser Fan Relay (K109). When Cooling Fan and Condenser Fan operation is required, the Engine Control Module (ECM) (Z132) grounds terminal 86 of the Condenser Fan Relay (K109). The relay energizes, applying battery voltage from fuse F3 of the Engine Compartment Fuse Box (P125) to the Cooling Fan Motors (M141, 142) and the Condenser Fan Motors (M113, M121). When Cooling Fan and Condenser Fan operation is no longer required, the ECM removes the ground supply to the Condenser Fan Relay (K109). The relay de-energizes, removing the voltage supply to the Cooling Fans (M141, M142) and the Condenser Fan Motors (M113, M121).

### Condenser Fan Operation (300Tdi)

The Condenser Fan Motors (M113, M121) on vehicles equipped with diesel engines operate when any one of the following conditions occur:

1. Coolant temperature exceeds 100°C (212°F).
2. The A/C is operating.

### Condenser Fan with High Coolant Temperature Operation (300Tdi)

When the Ignition Switch (X134) is in position II, battery voltage is applied to the Ignition Load Relay (K127). The relay is energized, applying battery voltage to the Condenser Fan Relay (K109). If the coolant temperature exceeds 100°C (212°F), the Condenser Fan Coolant Temperature Switch (X113) closes and energizes the Condenser Fan Relay (K109) by applying ground to the relay's coil. When the relay is energized, voltage from fuse F3 is applied to the Condenser Fan Motors (M113, M121) through the relay's contacts.

### Fan Operation with A/C (300Tdi)

With the Ignition Switch (X134) in position II, battery voltage is applied to the Ignition Load Relay (K127). The relay is energized, applying battery voltage to the Condenser Fan Relay (K109) when the Front A/C Switch (X225) is turned on and the Front Fan Speed Switch (X247) is turned to positions I, II, III, or IV, ground is applied to terminal 86 of the Condenser Fan Relay (K109). The relay energizes, applying battery voltage from fuse F3 to the Condenser Fan Motors (M113, M121).



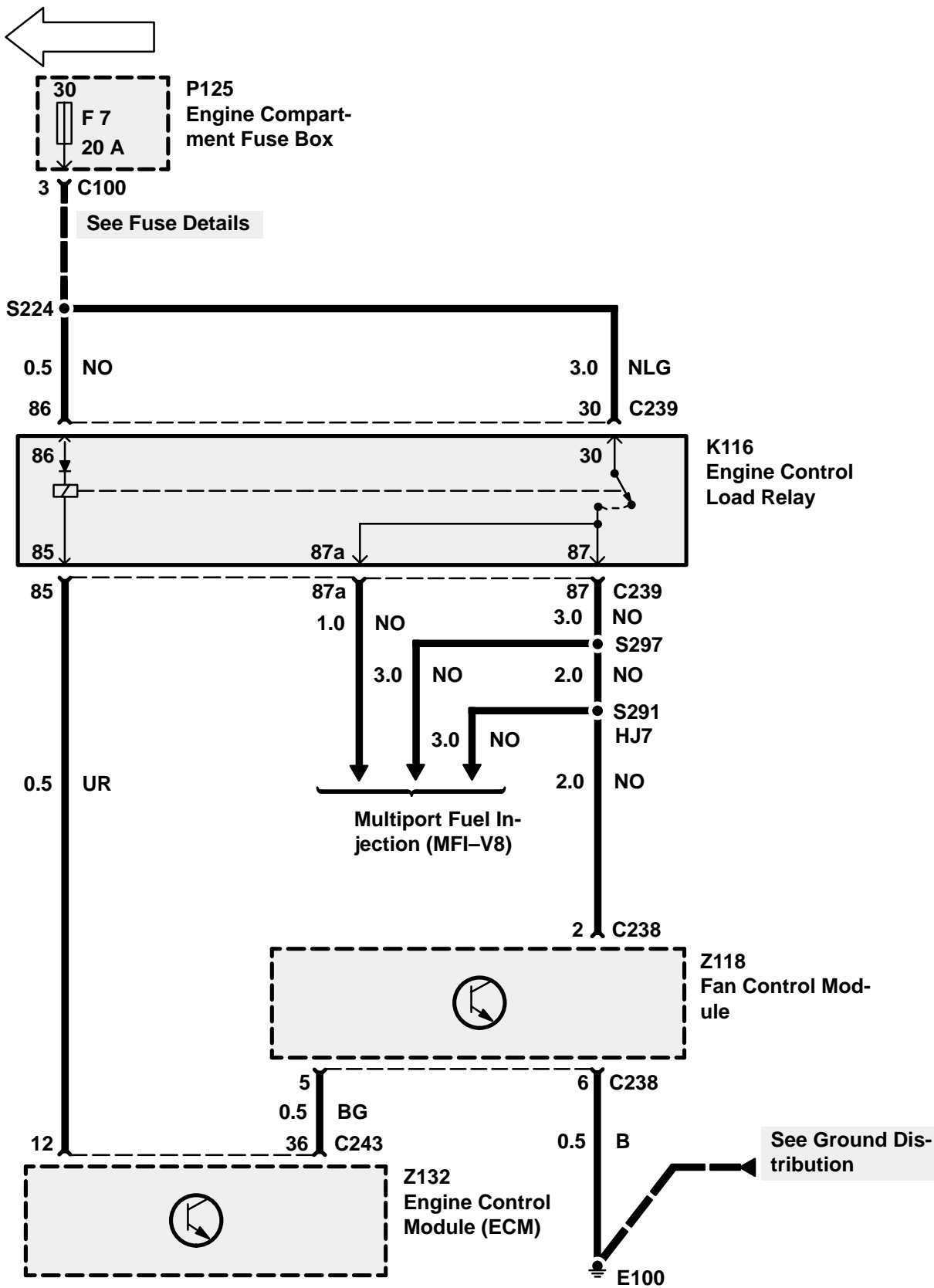

# K5 ETM

## DISCOVERY

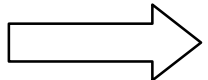
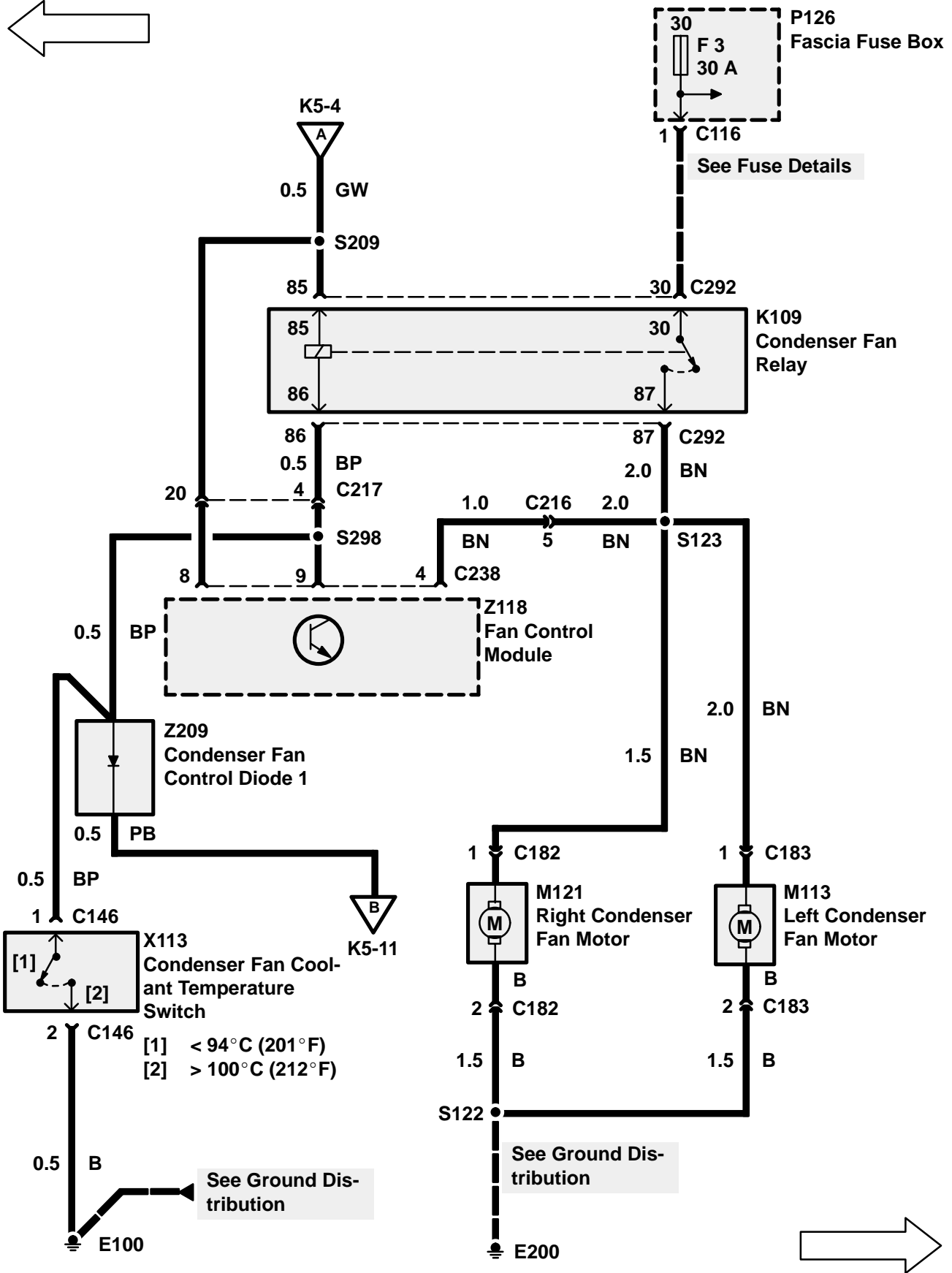
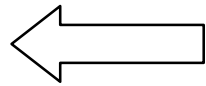

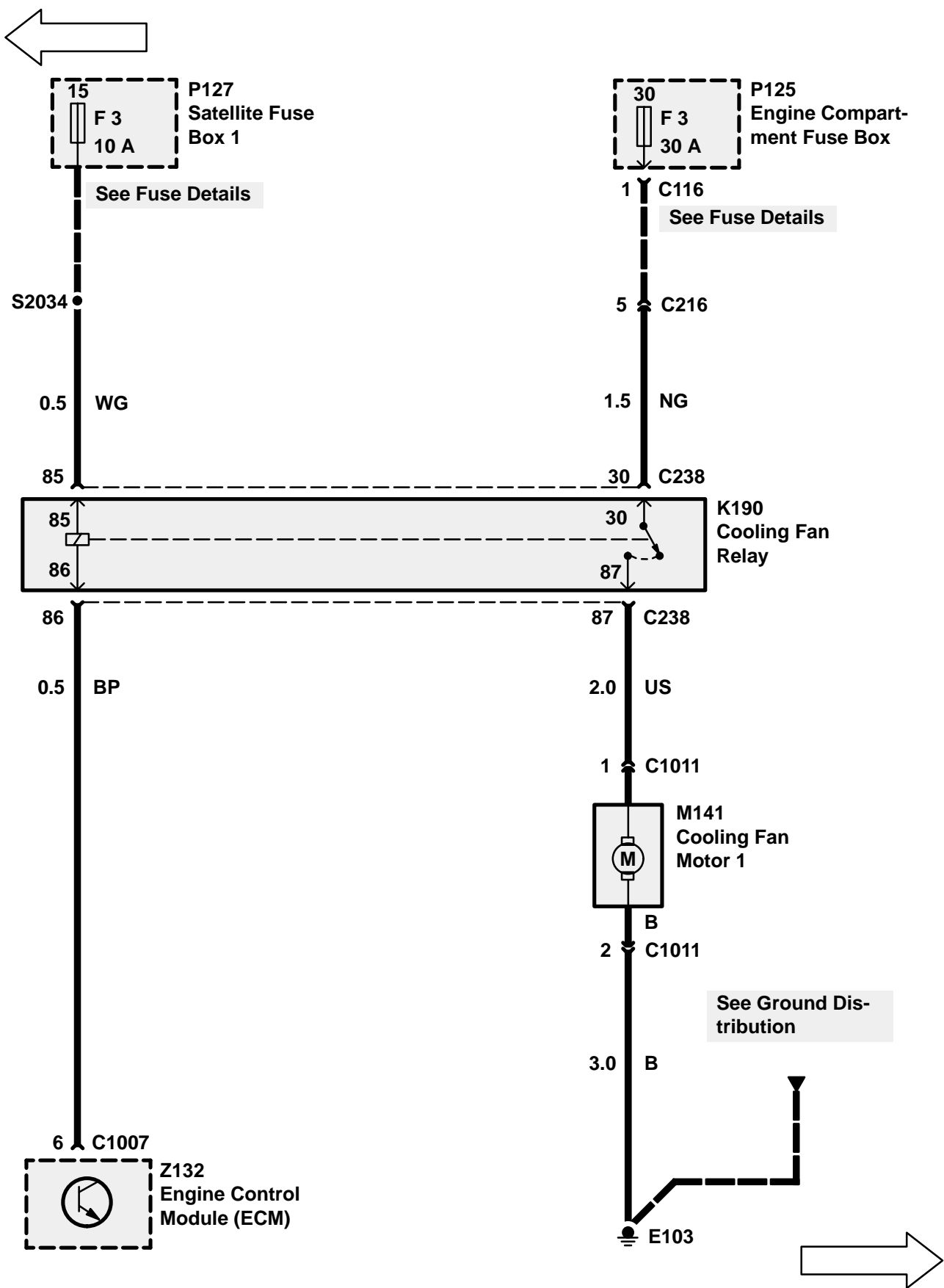

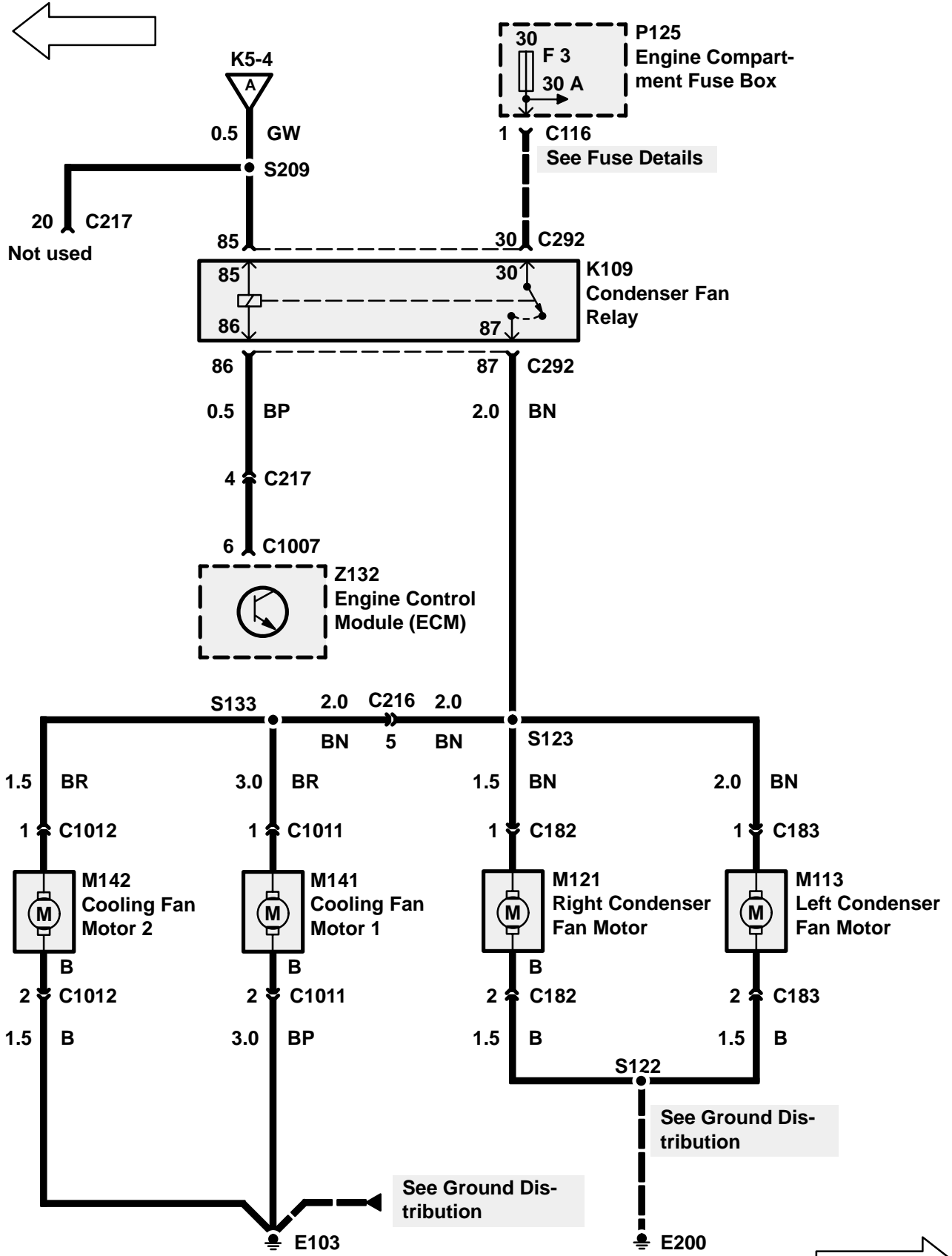



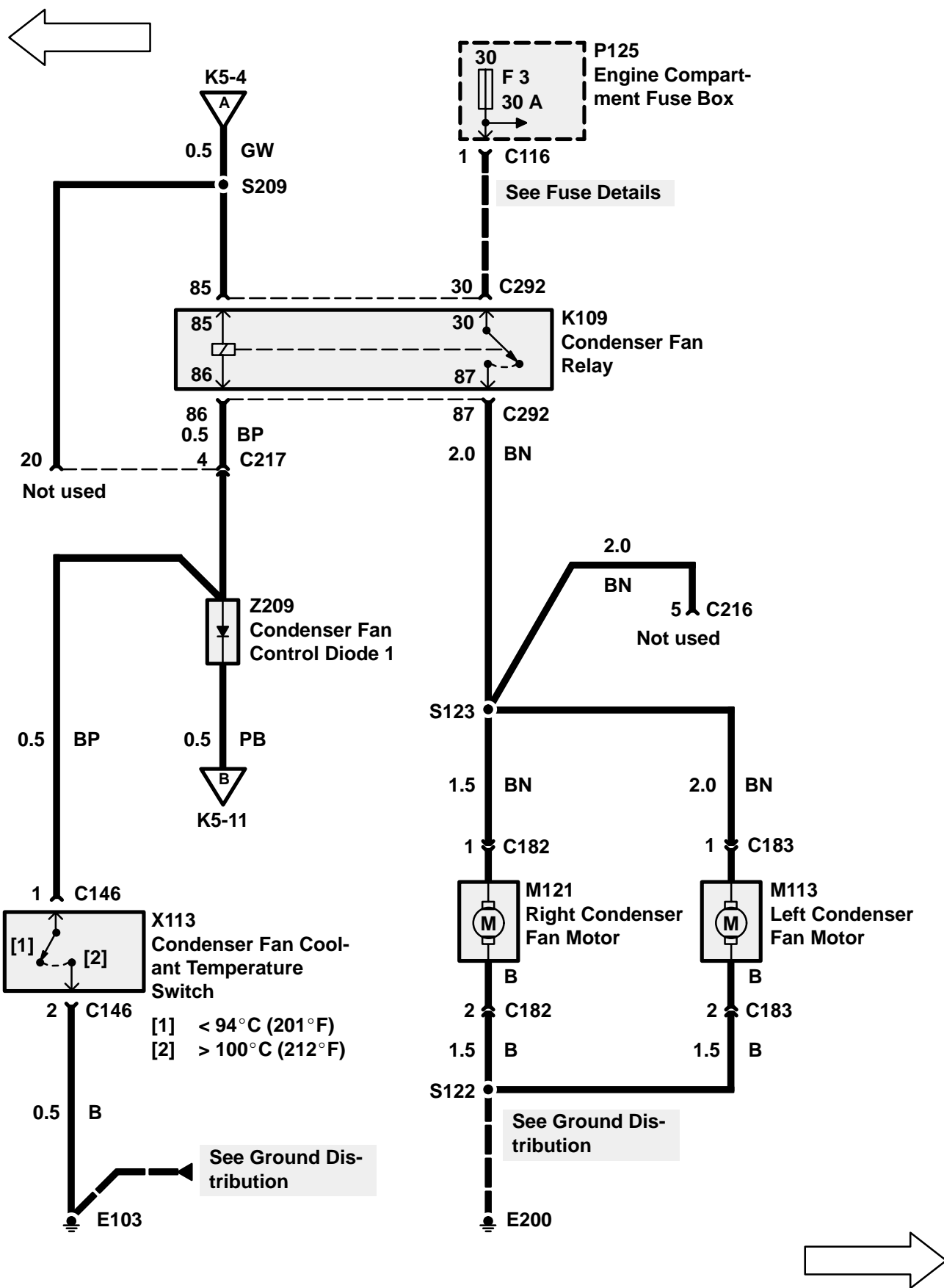

# K5 ETM

## DISCOVERY

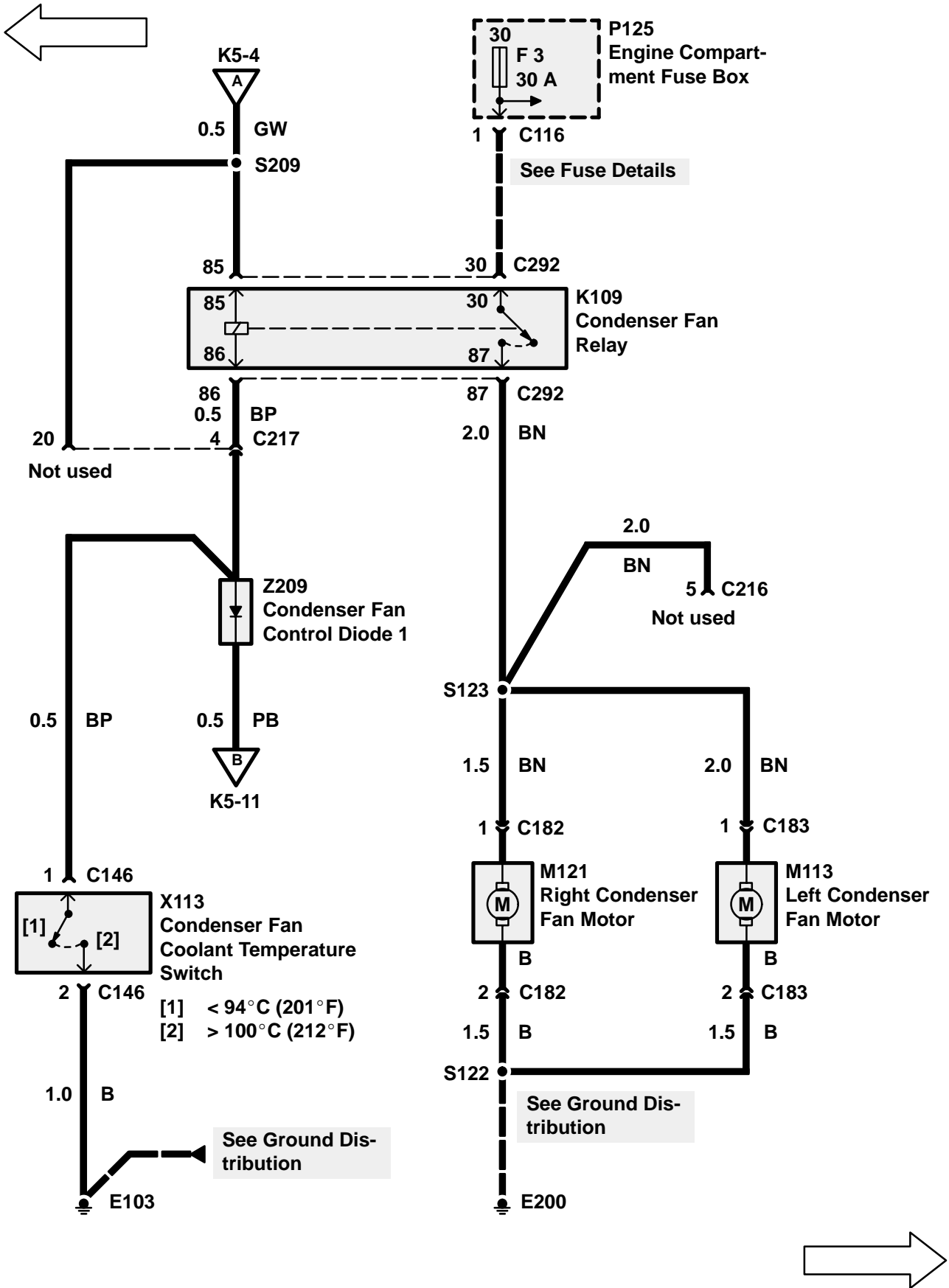

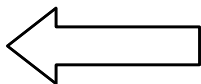

- K5-6 MFI-V8
- K5-9 300Tdi without EDC
- K5-10 300Tdi with EDC

Compressor Controls

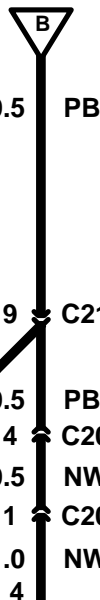
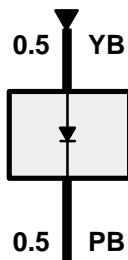

Compressor Controls

Interior Lamps

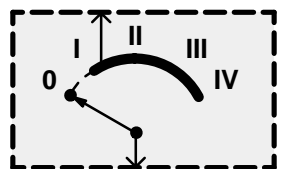
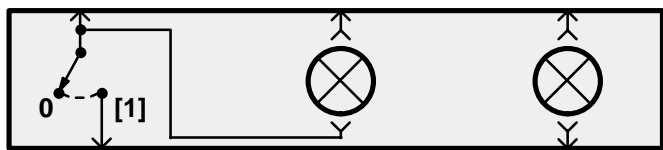
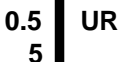

See Ground Distribution

S244 See Ground Distribution



**TROUBLESHOOTING HINTS**

1. Check Fuses F3, and F7 in the Engine Compartment Fuse Box (P125).
2. Check Fuse F15 in the Fascia Fuse Box (P126).
3. If the Blower Motor(s) do not operate normally, refer to Blower Controls, Section K1.

**SYSTEM DIAGNOSIS (MFI–V8)**

1. If the Condenser Fans do not turn on when the A/C is turned on, do Test A, the Condenser Fan Relay (K109) test.
2. If only one of the Condenser Fans operate, do Test H, the Condenser Fan Motor (M113, M121) test.
3. If the Condenser Fans do not turn on when coolant temperature exceeds 100°C (212°F), do Test J, the Temperature Switch (X113) test.
4. If the Condenser Fans do not stay on after the ignition has been turned off, fuel temperature exceeds 70°C and coolant temperature exceeds 110°C, do Test K, the Fan Control Module (Z118) test.

**SYSTEM DIAGNOSIS (MFI–T16)**

1. For models without A/C, if the Cooling Fan does not operate, do Test B, the Cooling Fan Relay (K190) test.
2. For models with A/C, if the fans do not operate, do Test C, the Condenser Fan Relay (K109) test.
3. If only one of the Condenser Fans operate, do Test H, the Condenser Fan Motor (M113, M121) test.
4. If only one of the Cooling Fans operate, do Test I, the Cooling Fan (M141, M142) test.

**SYSTEM DIAGNOSIS (300TDI WITH EDC)**

1. If the Condenser Fans do not turn on when the A/C is turned on, do Test D, the Condenser Fan Relay (K109) test.
2. If only one of the Condenser Fans operate, do test H, the Condenser Fan Motor (M113, M121) test.

3. If the Condenser Fans do not turn on when coolant temperature exceeds 100°C (212°F), do Test J, the Temperature Switch (X113) test.

**SYSTEM DIAGNOSIS (300 TDI WITHOUT EDC)**

1. If the Condenser Fans do not turn on when the A/C is turned on, do Test E, the Condenser Fan Relay (K109) test.
2. If only one of the Condenser Fans operate, do Test H, the Condenser Fan Motor (M113, M121) test.
3. If the Condenser Fans do not turn on when the coolant temperature exceeds 100°C (212°F), do Test S, the Temperature Switch test.

Test A

R050001

1A

### Condenser Fan Relay Test MFI-V8

**CONDITIONS**

- Ignition Switch  
*Position: 0*

**RESULTS**  
*BAT VOLT*

K109  
Condenser Fan  
Relay

~~OK~~ **PROBLEM CAUSE**

- F3 Fuse
- NG Wire

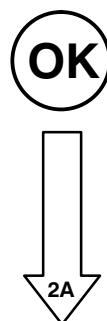

R050001

2A

**CONDITIONS**

- Ignition Switch  
*Position: II*
- Engine  
*On*

**RESULTS**  
*BAT VOLT*

K109  
Condenser Fan  
Relay

~~OK~~ **PROBLEM CAUSE**

- GW Wire
- Fan Timer Diode

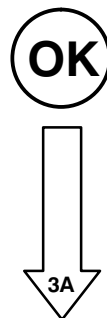

3A
2A
R090002

**CONDITIONS**

- Ignition Switch  
*Position: II*
- Front Fan Speed Switch  
*Position: I*
- Front A/C Switch  
*A/C Mode*

**RESULTS**

*Less than 1 ohm*

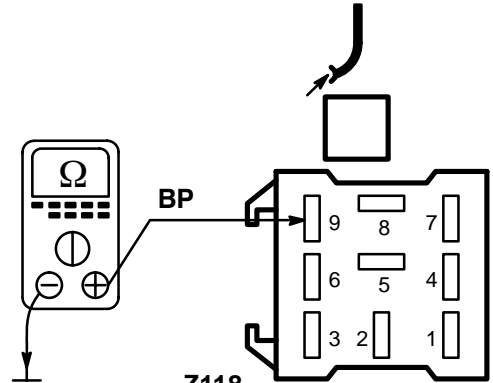

**Z118**  
Fan Control Module

~~OK~~ GO TO TEST F

OK

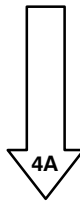

4A
R050001

**CONDITIONS**

- Ignition Switch  
*Position: 0*

**RESULTS**

- M113, M121 Condenser Fan Motors  
*Operate*

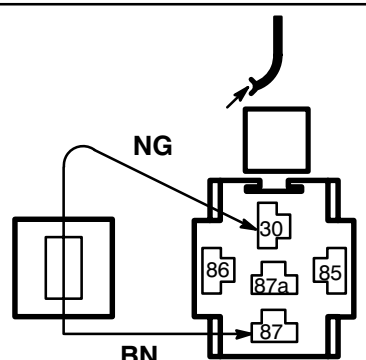

**K109**  
Condenser Fan Relay

~~OK~~ PROBLEM CAUSE  
- BN Wire

OK PROBLEM CAUSE  
- Condenser Fan Relay

Test B

R050001

1B

### Cooling Fan Relay Test MFI-T16

**CONDITIONS**

- Ignition Switch  
*Position: 0*

**RESULTS**  
*BAT VOLT*

K190  
Cooling Fan  
Relay

~~OK~~ **PROBLEM CAUSE**

- F3 Fuse
- NG Wire

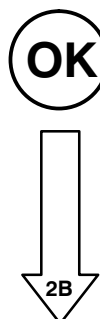

R050001

2B

**CONDITIONS**

- Ignition Switch  
*Position: II*

**RESULTS**  
*BAT VOLT*

K190  
Cooling Fan  
Relay

~~OK~~ **PROBLEM CAUSE**

- F3 Fuse
- WG Wire

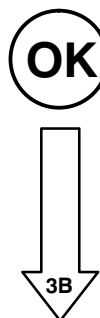

3B
2B
R020011

**CONDITIONS**

- Ignition Switch  
*Position: 0*

**RESULTS**

*Less than 1 ohm*

**M141**  
Cooling Fan  
Motor 1

OK **PROBLEM CAUSE**

- B Wire
- E103

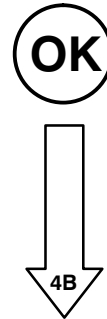

4B
R360001

**CONDITIONS**

- Ignition Switch  
*Position: II*

**RESULTS**

- Cooling Fan Motor 1  
*Operates*

**Z132**  
Engine Control  
Module (ECM)

**C1007**

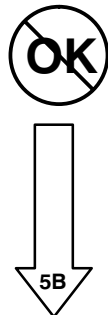

OK **PROBLEM CAUSE**

- BP Wire
- Engine Control Module (ECM)



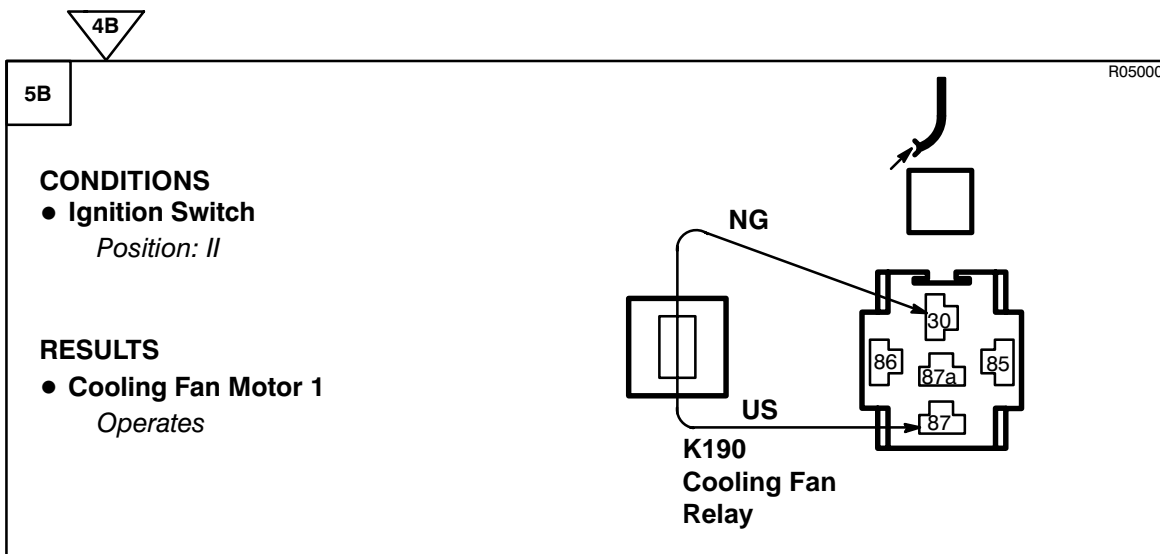

~~OK~~ PROBLEM CAUSE  
 - US Wire  
 - Cooling Fan Motor 1

OK PROBLEM CAUSE  
 - Cooling Fan Relay

**Test C**

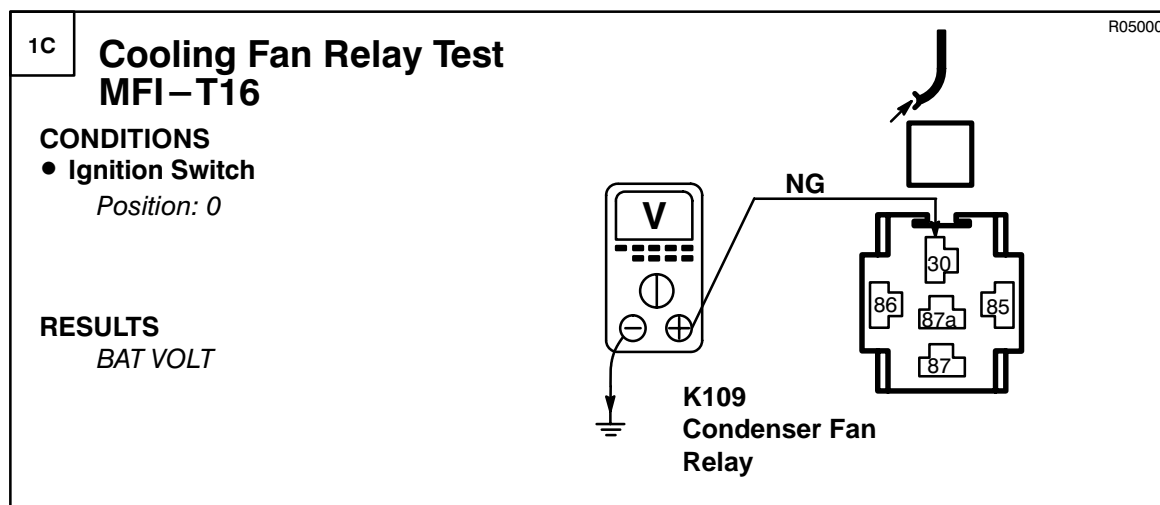

~~OK~~ PROBLEM CAUSE  
 - F3 Fuse  
 - NG Wire

OK

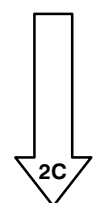

1C

2C

R050001

**CONDITIONS**

- Ignition Switch  
*Position: II*
- Engine  
*On*

**RESULTS**  
*BAT VOLT*

**K109**  
Condenser Fan Relay

~~OK~~ **PROBLEM CAUSE**

- GW Wire
- Fan Timer Diode

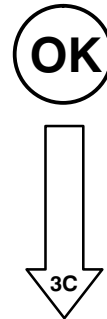

3C

3C

R360001

**CONDITIONS**

- Ignition Switch  
*Position: II*

**RESULTS**

- Fan Motors  
*Operate*

**Z132**  
Engine Control Module (ECM)

**C1007**

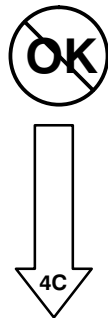

OK **PROBLEM CAUSE**

- BP Wire
- Engine Control Module (ECM)

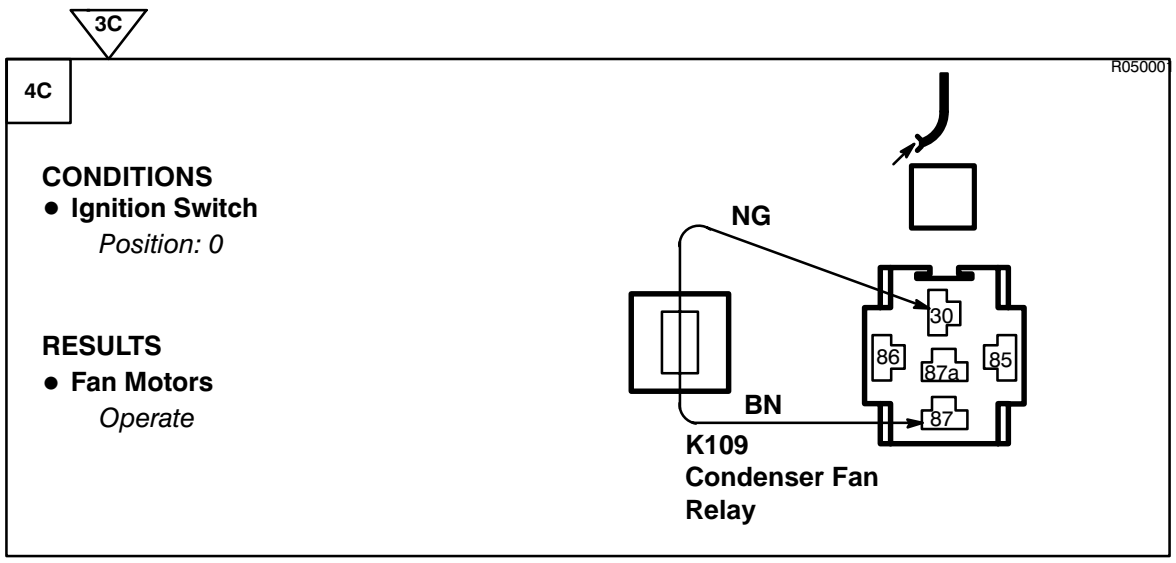

~~OK~~ PROBLEM CAUSE  
- BN Wire

OK PROBLEM CAUSE  
- Condenser Fan Relay

**Test D**

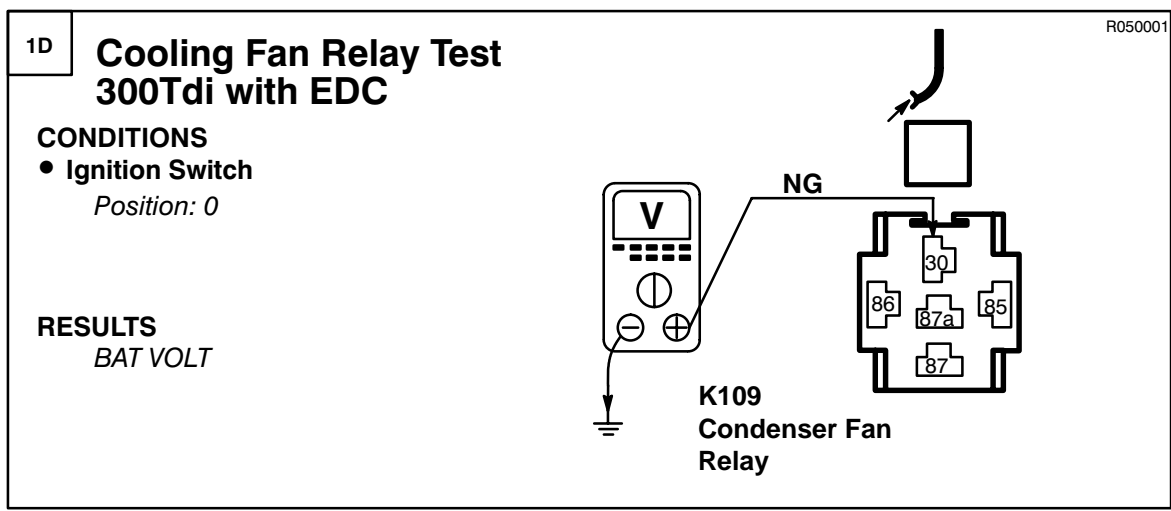

~~OK~~ PROBLEM CAUSE  
- F3 Fuse  
- NG Wire

OK

↓  
2D

2D
1D
R050001

**CONDITIONS**

- Ignition Switch  
*Position: II*
- Engine  
*On*

**RESULTS**  
*BAT VOLT*

**K109  
Condenser Fan  
Relay**

~~OK~~

**PROBLEM CAUSE**  
 - GW Wire  
 - Fan Timer Diode

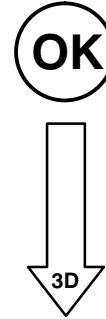

3D
R050001

**CONDITIONS**

- Ignition Switch  
*Position: II*
- Front Fan Speed Switch  
*Position: I*
- Front A/C Switch  
*A/C Mode*

**RESULTS**  
*Less than 1 ohm*

**K109  
Condenser Fan  
Relay**

~~OK~~

**GO TO TEST G**

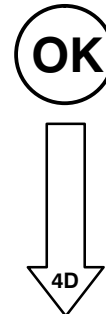

R050001

3D

4D

**CONDITIONS**

- Ignition Switch  
*Position: 0*

**RESULTS**

- M113, M121 Condenser Fan Motors  
*Operate*

NG

BN

K109  
Condenser Fan  
Relay

~~OK~~ PROBLEM CAUSE  
- BN Wire

OK PROBLEM CAUSE  
- Condenser Fan Relay

**Test E**

R050001

1E

**Condenser Fan Relay Test  
300Tdi without EDC**

**CONDITIONS**

- Ignition Switch  
*Position: 0*

**RESULTS**

*BAT VOLT*

NG

V

K109  
Condenser Fan  
Relay

~~OK~~ PROBLEM CAUSE  
- F3 Fuse  
- NG Wire

OK

↓

2E

1E

2E

**CONDITIONS**

- Ignition Switch  
*Position: II*
- Engine  
*On*

**RESULTS**  
*BAT VOLT*

**K109  
Condenser Fan  
Relay**

R050001

~~OK~~ **PROBLEM CAUSE**

- GW Wire
- Fan Timer Diode

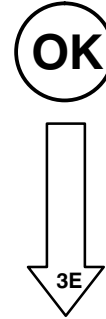

3E

3E

**CONDITIONS**

- Ignition Switch  
*Position: II*
- Front Fan Speed Switch  
*Position: I*
- Front A/C Switch  
*A/C Mode*

**RESULTS**  
*BAT VOLT*

**K109  
Condenser Fan  
Relay**

R050001

~~OK~~ **GO TO TEST G**

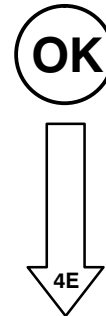

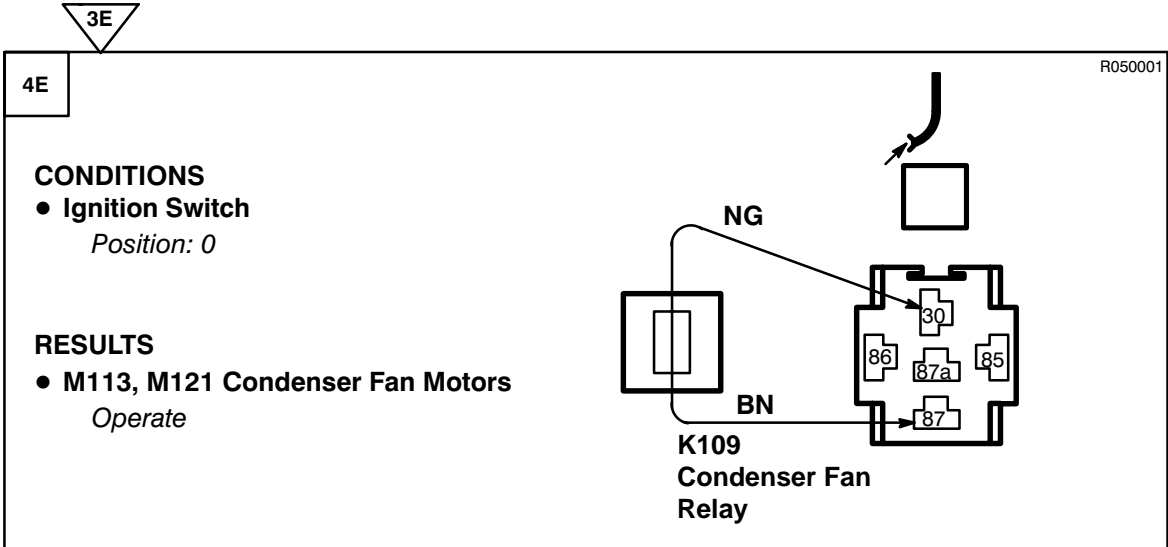

**OK** PROBLEM CAUSE  
- BN Wire

**OK** PROBLEM CAUSE  
- Condenser Fan Relay

## Test F

**1F A/C Mode****CONDITIONS**

- Ignition Switch  
*Position: II*
- Front Fan Speed Switch  
*Position: I*
- Front A/C Switch  
*A/C Mode*

**RESULTS**

- Compressor Clutch  
*On*
- Front Blower Motor  
*On*

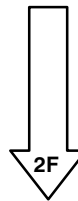

GO TO SECTION K1

**2F****CONDITIONS**

- Ignition Switch  
*Position: II*
- Front Fan Speed Switch  
*Position: I*
- Front A/C Switch  
*A/C Mode*

**RESULTS**

- M113, M121 Condenser Fan Motors  
*Operate*

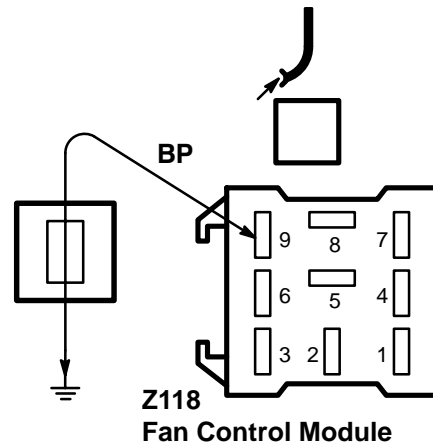

R090002

PROBLEM CAUSE  
- BP WirePROBLEM CAUSE  
- PB Wire  
- Condenser Fan  
Control Diode 1



**Test G**

**1G A/C Mode**

**CONDITIONS**

- Ignition Switch  
*Position: II*
- Front Fan Speed Switch  
*Position: I*
- Front A/C Switch  
*A/C Mode*

**RESULTS**

- Compressor Clutch  
*On*
- Front Blower Motor  
*On*

~~OK~~ GO TO SECTION K1

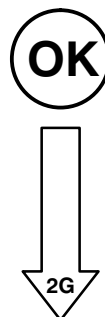

**2G** R200003

**CONDITIONS**

- Ignition Switch  
*Position: II*
- Front Fan Speed Switch  
*Position: I*
- Front A/C Switch  
*A/C Mode*

**RESULTS**

- M113, M121 Condenser Fan Motors  
*Operate*

~~OK~~ PROBLEM CAUSE  
- BP Wire

OK PROBLEM CAUSE  
- PB Wire  
- Condenser Fan Control Diode 1

### Test H

R020011

1H

### Condenser Fan Motor Test

**CONDITIONS**

- Ignition Switch  
*Position: II*
- Front Fan Speed Switch  
*Position: I*
- Front A/C Switch  
*A/C Mode*

**RESULTS**  
*BAT VOLT*

~~OK~~

**PROBLEM CAUSE**  
 - BN Wire

OK



R020011

2H

**CONDITIONS**

- Ignition Switch  
*Position: 0*

**RESULTS**  
*Less than 1 ohm*

~~OK~~

**PROBLEM CAUSE**  
 - B Wire  
 - Ground Connections

OK

**PROBLEM CAUSE**  
 - M113, M121 Condenser Fan Motor

**Test I**

R020011

11

### Cooling Fan Motor Test

**CONDITIONS**

- Ignition Switch  
*Position: II*
- Front Fan Speed Switch  
*Position: I*
- Front A/C Switch  
*A/C Mode*

**RESULTS**  
*BAT VOLT*

**M141, M142 Cooling Fan Motor**

~~OK~~ **PROBLEM CAUSE**  
- BR Wire

**OK**

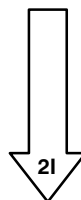

R020011

21

### Cooling Fan Motor Test

**CONDITIONS**

- Ignition Switch  
*Position: 0*

**RESULTS**  
*Less than 1 ohm*

**M141, M142 Cooling Fan Motor**

~~OK~~ **PROBLEM CAUSE**  
- B Wire  
- Ground Connections

**OK** **PROBLEM CAUSE**  
- M141, M142 Cooling Fan Motor

### Test J

R020003

1J

### Temperature Switch Test

**CONDITIONS**

- Ignition Switch  
*Position: II*

**RESULTS**

*BAT VOLT*

**X113**  
Condenser Fan  
Coolant Tem-  
perature Switch



**PROBLEM CAUSE**  
- BP Wire

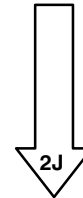

R020003

2J

### Temperature Switch Test

**CONDITIONS**

- Ignition Switch  
*Position: II*

**RESULTS**

- M113, M121 Condenser Fan Motors  
*Operate*

**X113**  
Condenser Fan  
Coolant Tem-  
perature Switch



**PROBLEM CAUSE**  
- B Wire  
- E100  
- E103



**PROBLEM CAUSE**  
- Condenser Fan  
Coolant Tem-  
perature Switch

Test K

R090002

1K

### Fan Timer Test

**CONDITIONS**

- Ignition Switch  
*Position: II*
- Engine  
*On*

**RESULTS**  
*BAT VOLT*

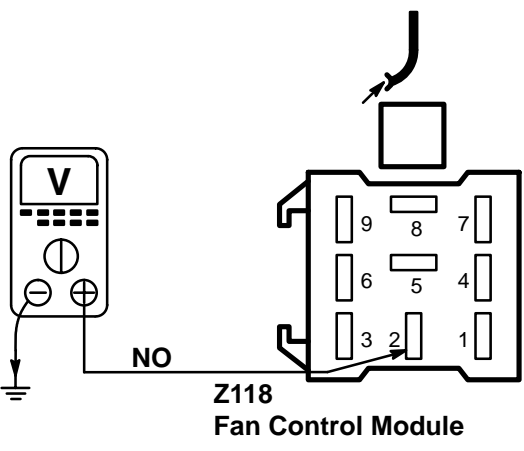

Z118  
Fan Control Module

~~OK~~ PROBLEM CAUSE  
- NO Wire

OK

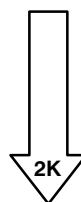

R090002

2K

**CONDITIONS**

- Ignition Switch  
*Position: 0*

**RESULTS**  
*Less than 1 ohm*

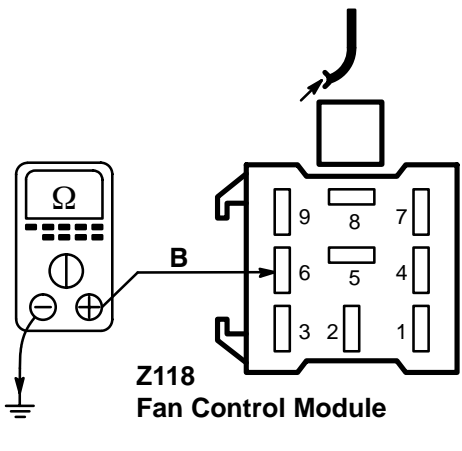

Z118  
Fan Control Module

~~OK~~ PROBLEM CAUSE  
- B Wire  
- E100

OK

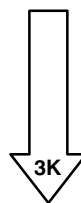

2K

3K

**CONDITIONS**

- Ignition Switch  
*Position: II*

**RESULTS**

- M113, M121 Condenser Fan Motors  
*Operate*

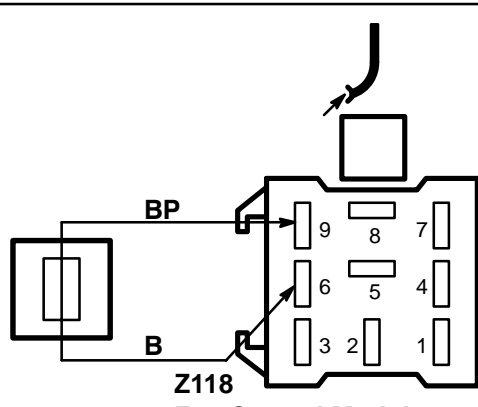

**Z118  
Fan Control Module**

R090002



**PROBLEM CAUSE**

- BP Wire
- B Wire

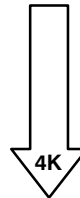

4K

4K

**CONDITIONS**

- Ignition Switch  
*Position: II*
- Engine  
*On*

**RESULTS**

- M113, M121 Condenser Fan Motors  
*Operate*

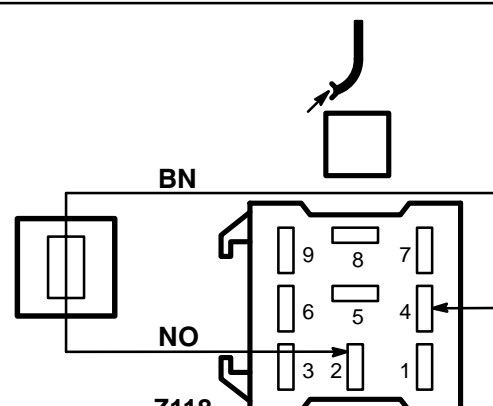

**Z118  
Fan Control Module**

R090002



**PROBLEM CAUSE**

- BN Wire

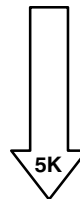

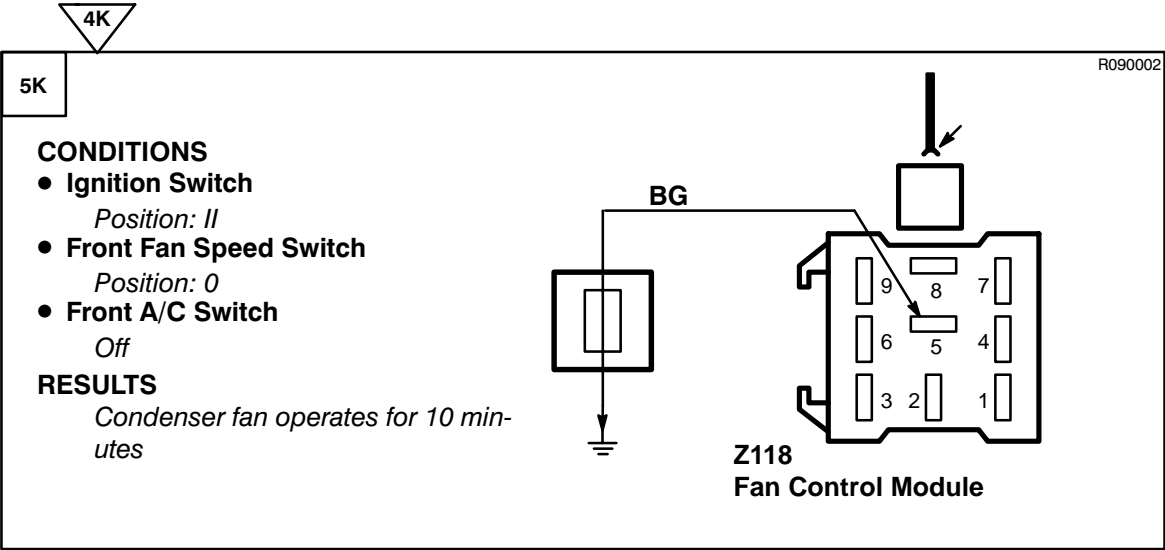

**OK** PROBLEM CAUSE  
- Fan Control Module

**OK** PROBLEM CAUSE  
- BG Wire  
- Engine Control Module (ECM)

## CIRCUIT OPERATION

Voltage for window lift and sunroof operation is provided to the Window Lift ECU (Z147) from fuses F1 and F2. The Window Lift ECU is grounded through the B wire at ground E201.

### Timeout Feature

Fuse F15 applies voltage to the Window Lift ECU terminal 3 when the ignition switch is on. When the ignition switch is turned off, the absence of voltage at terminal 3 signals the Window Lift ECU to start the timeout feature. When the timeout feature is activated, the Window Lift ECU will allow window and sunroof operation for an additional 45 seconds.

The timeout feature will be cancelled if the driver's door is opened and then closed. The Window Lift ECU monitors the door's position at terminal 7.

### Front Window Operation

When a Front Window Switch is operated, the switch grounds one of four Window Lift ECU input terminals. This signals the Window Lift ECU to apply voltage and ground to the respective window motor. If the front window switch is held in the down position for more than 1/2 second, the express down feature is activated. The Window Lift ECU will operate the window motor until it is completely lowered.

### Rear Window

The Window Lift ECU terminal E supplies voltage to the Rear Window Console and door switches for rear window operation.

When a window console switch is in the 'DOWN' position, voltage is applied to the window motor through the 'up' switch contacts. The window motors operate because they are grounded through the 'down' contacts of the window console switch. When a switch is in the 'UP' position, the polarity applied to the window motor is reversed, causing the motor to run in the opposite direction and the window to close.

### Rear Window Isolation Switch (X187)

The Rear Window Isolation Switch (X187) is placed in series with the ground supply to the Rear Window Door Switches (X188, X189). If the isolation switch is opened, the ground supply is interrupted, preventing rear window operation using the rear door switches.



# L1 ETM

## DISCOVERY

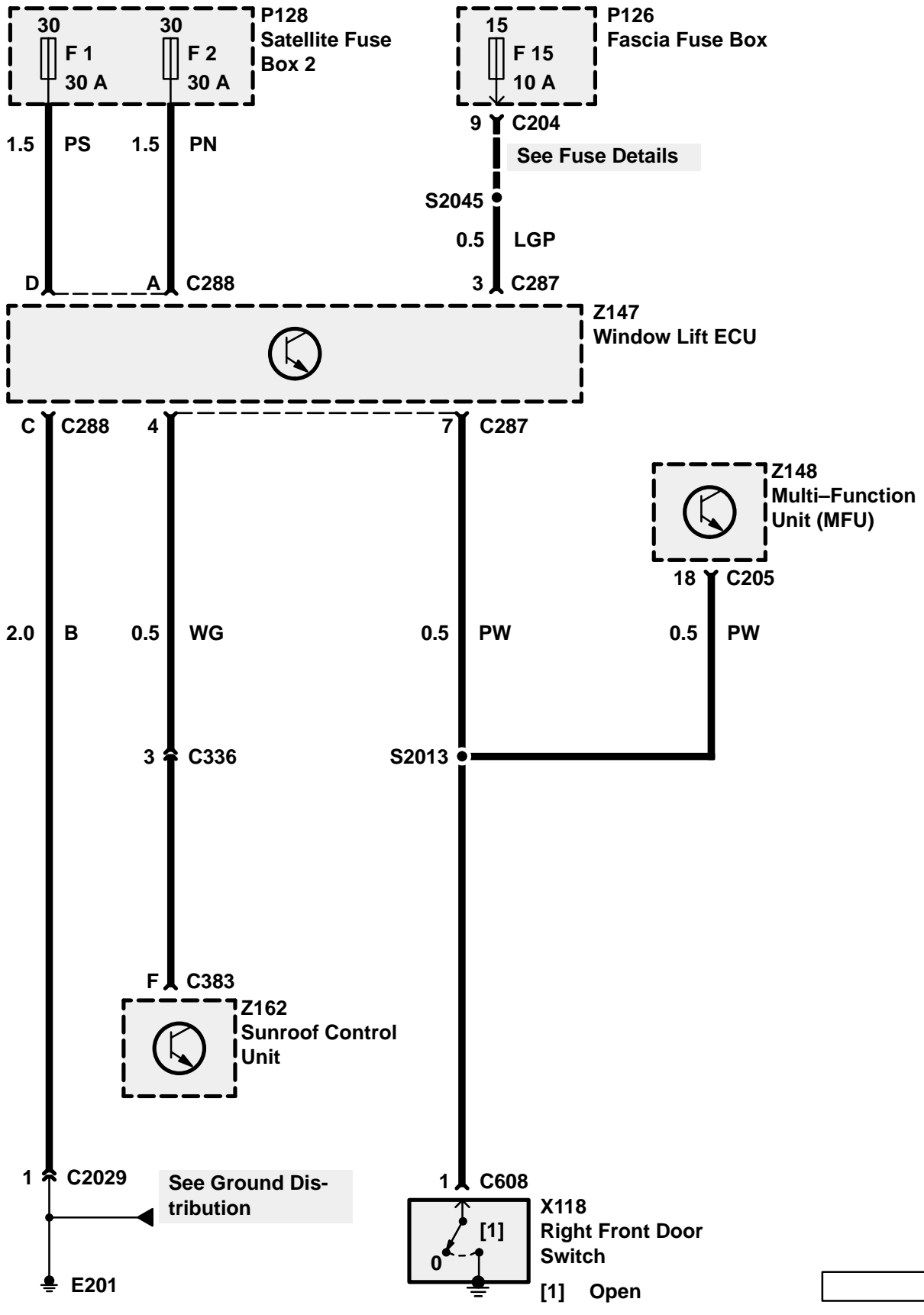



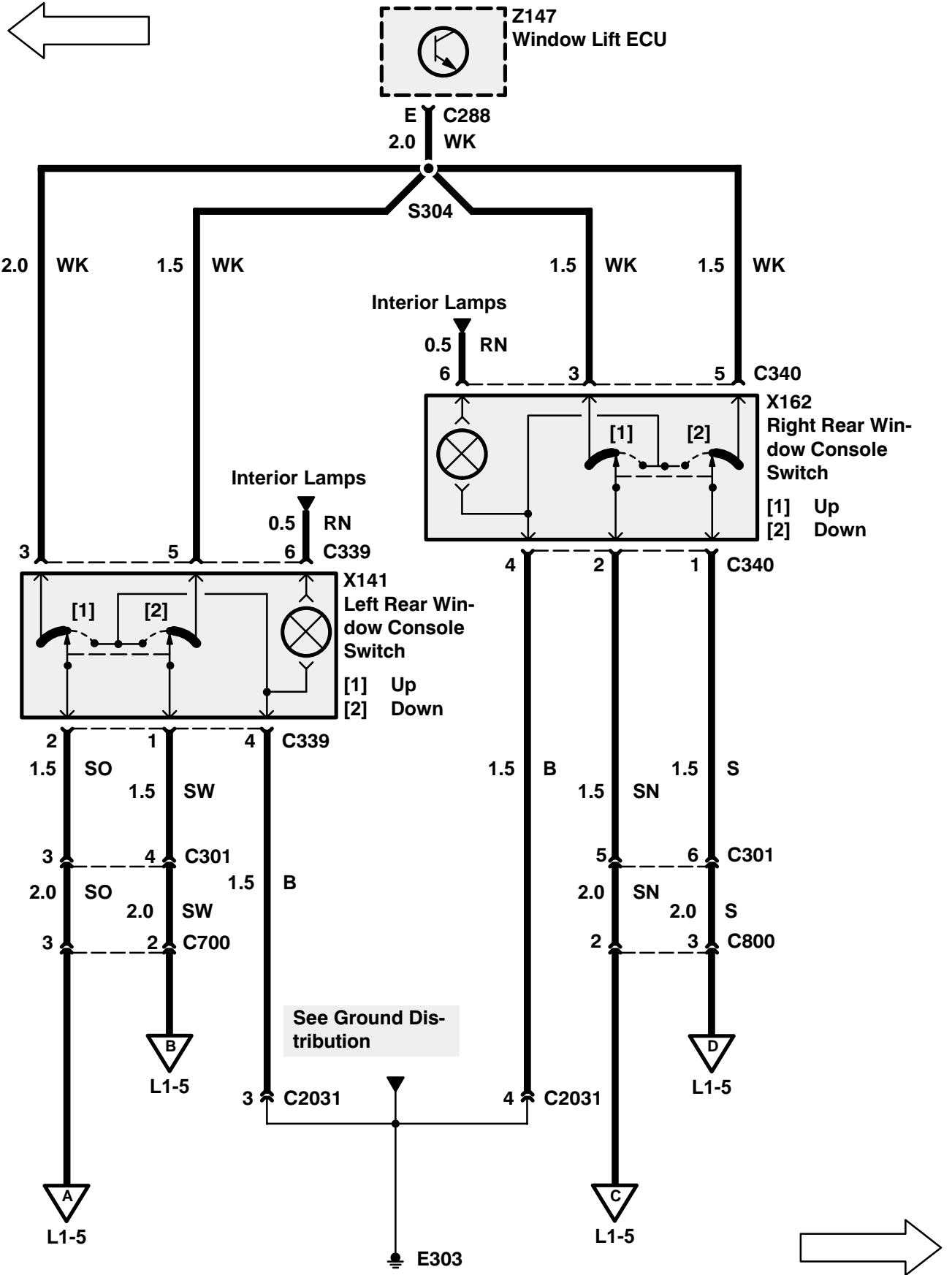

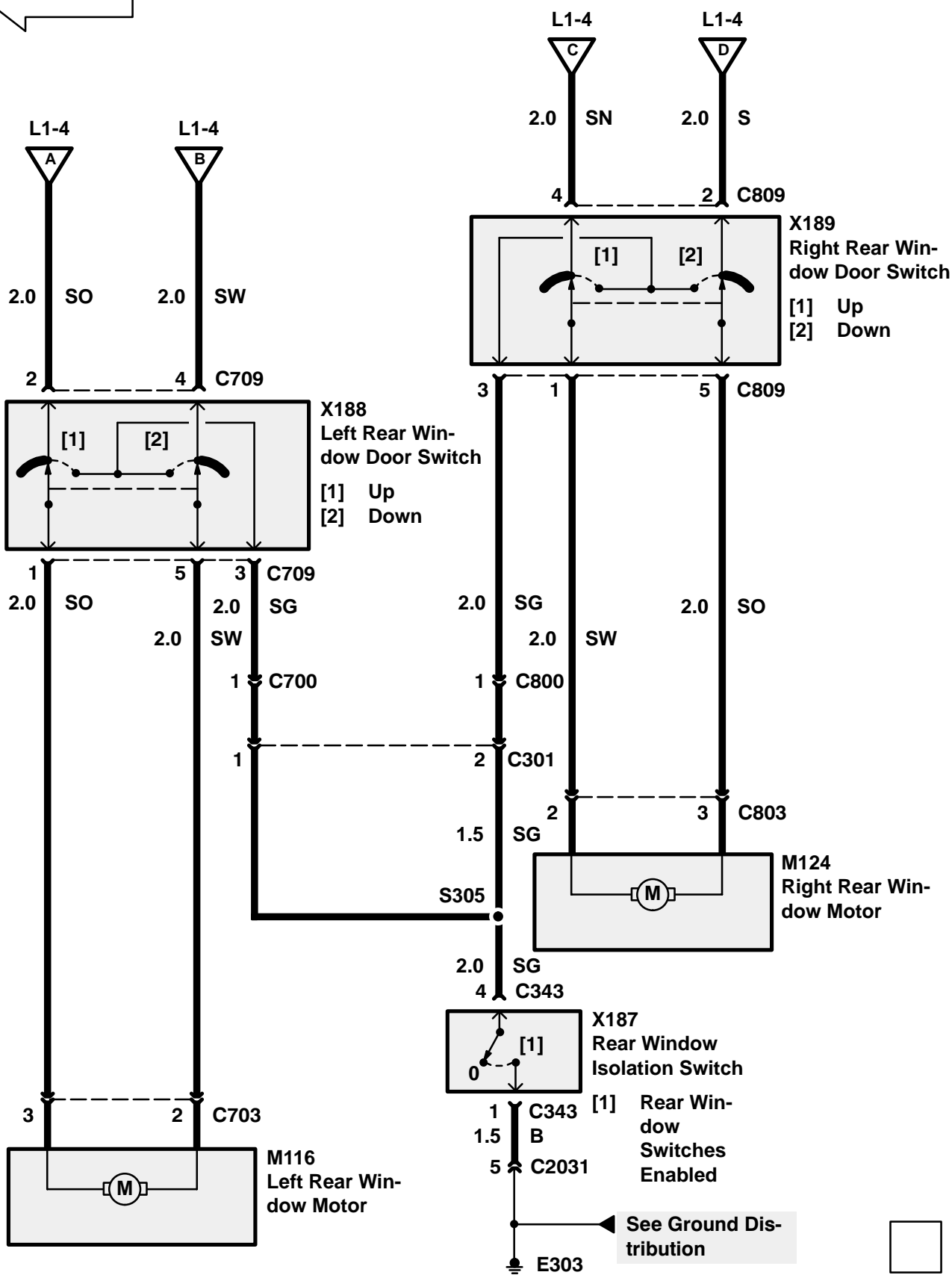
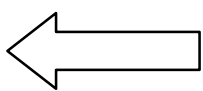

**TROUBLESHOOTING HINTS**

3. If the one touch window feature does not operate but the window operates, replace the Window Lift ECU (Z147).

**SYSTEM DIAGNOSIS**

1. If none of the windows operate, do Test A.
2. If both rear windows do not operate from the rear door switches but do operate when the centre console switches are used, do test B.
3. If the rear windows do not operate from the centre console switches and the rear door switches, do Test C.
4. If one rear window does not operate from the centre console and door switch, do Test D.
5. If a rear window does not operate using the door switch but does operate from the centre console switch, do Test F.
6. If a rear window does not operate from the centre console switch but does work when the door switch is used, do Test E.
7. If a front window does not operate, do Test G.
8. If the window timeout feature does not operate, do test H.

Test A

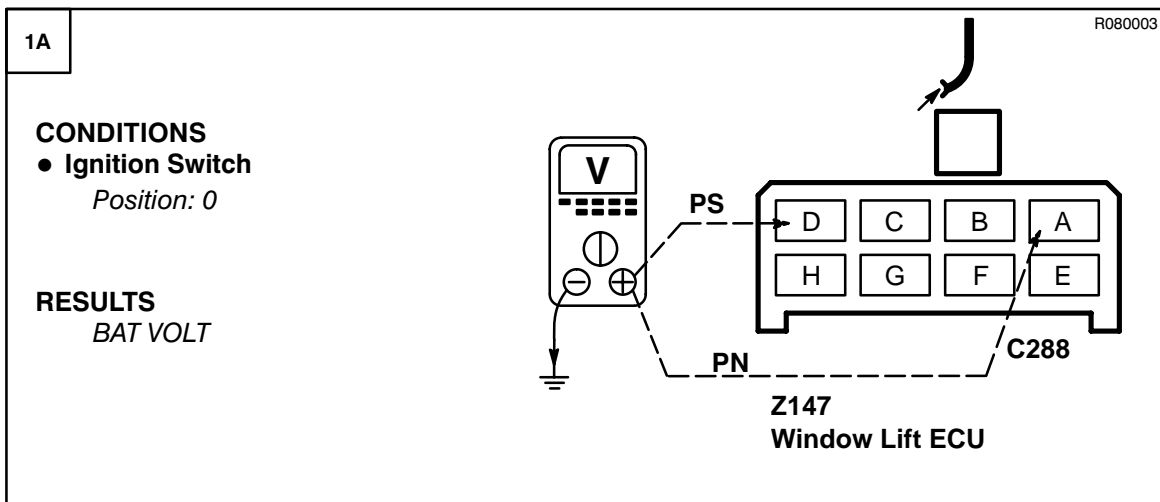

~~OK~~ **PROBLEM CAUSE**

- F1 Fuse
- PS Wire
- F2 Fuse
- PN Wire

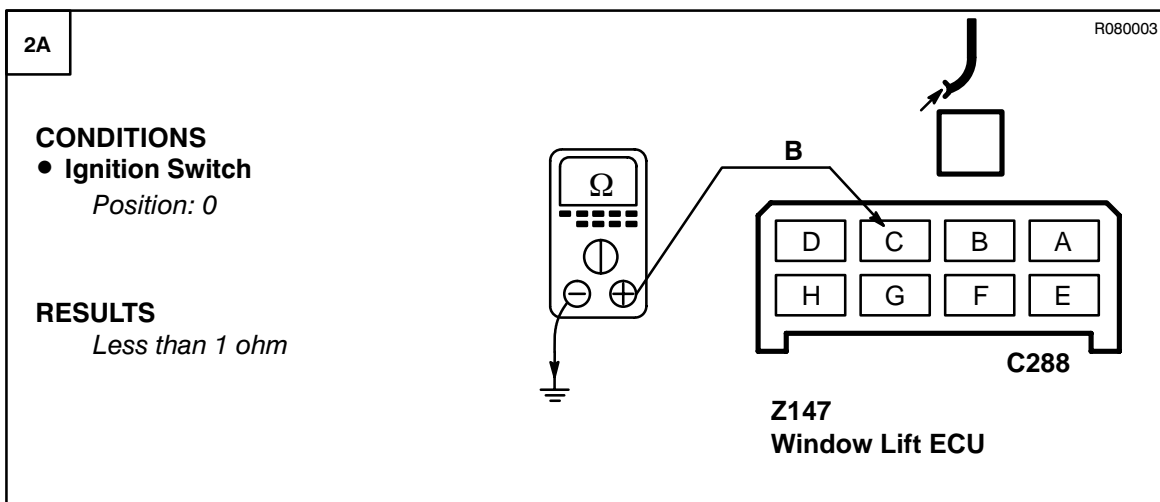
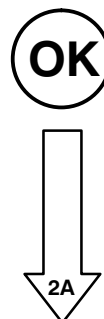

~~OK~~ **PROBLEM CAUSE**

- B Wire

OK **PROBLEM CAUSE**

- Window Lift ECU

Test B

R060019

1B

**CONDITIONS**

- Ignition Switch  
*Position: I*
- Rear Window Isolation Switch  
*On*

**RESULTS**  
*Less than 1 ohm*

X187  
Rear Window  
Isolation Switch



**PROBLEM CAUSE**  
- Rear Window Isolation Switch



**PROBLEM CAUSE**  
- B Wire  
- SG Wire

**Test C**

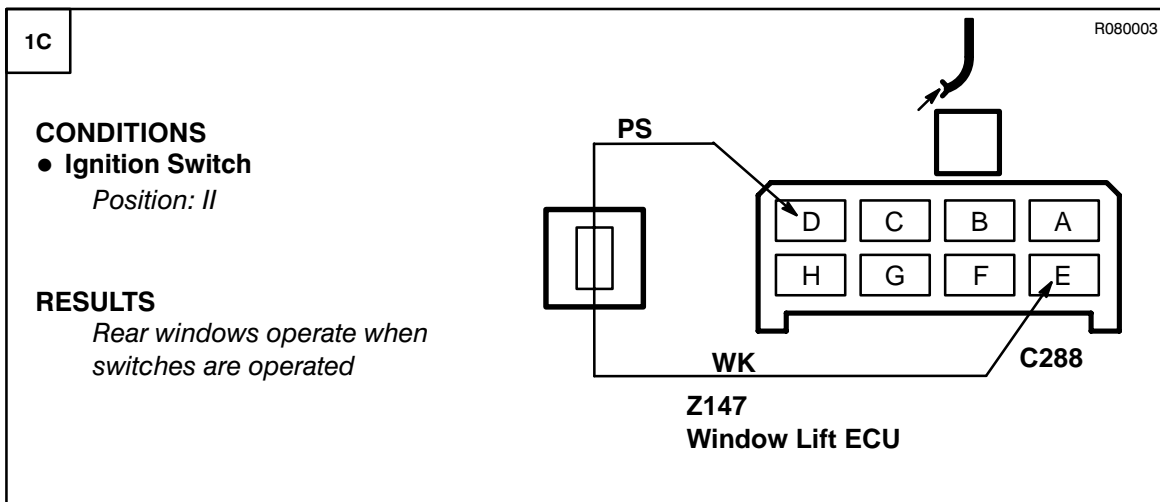

**OK** PROBLEM CAUSE  
 - WK Wire

**OK** PROBLEM CAUSE  
 - Window Lift ECU

**Test D**

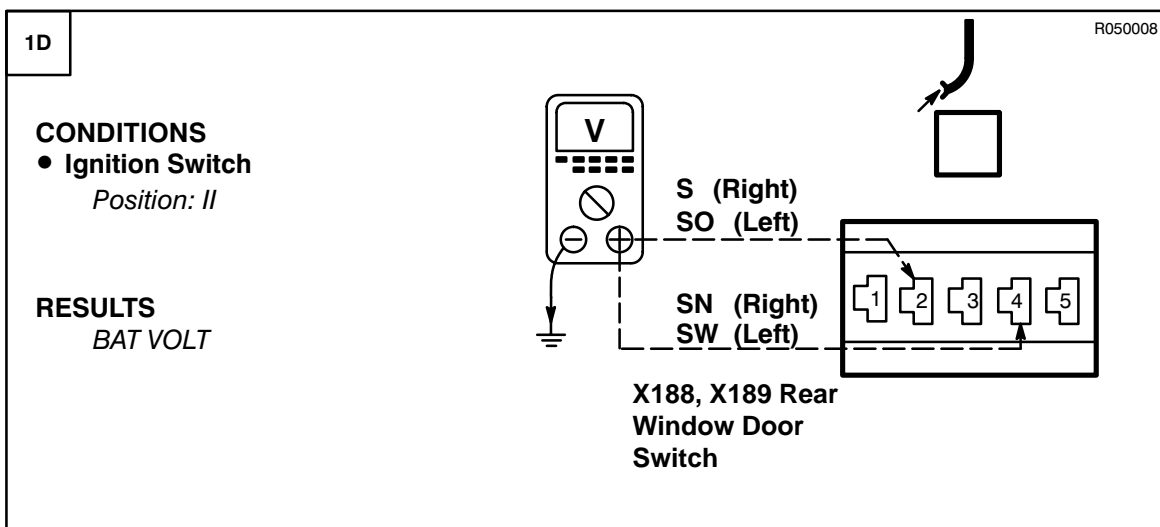

**OK** GO TO TEST E

**OK**  
 ↓  
 2D



R030021

1D

2D

**CONDITIONS**

- Ignition Switch  
*Position: II*

**RESULTS**  
*BAT VOLT*

M116, M124 Rear Window Motor



**PROBLEM CAUSE**

- SW Wire
- SO Wire
- X188, X189 Rear Window Door Switch



R030021

3D

**CONDITIONS**

- Ignition Switch  
*Position: II*

**RESULTS**

- X188, X189 Rear Window Door Switch

⚡ = 0 VOLT  
 Off = BAT VOLT

M116, M124 Rear Window Motor



**PROBLEM CAUSE**

- SW Wire
- SO Wire
- X188, X189 Rear Window Door Switch

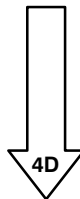

3D

4D

R030021

**CONDITIONS**

- Ignition Switch  
*Position: II*

**RESULTS**

- X188, X189 Rear Window Door Switch

▲ = 0 VOLT  
Off = BAT VOLT

M116, M124 Rear Window Motor

**OK** PROBLEM CAUSE

- SO Wire
- SW Wire
- X188, X189 Rear Window Door Switch

**OK** PROBLEM CAUSE

- M116, M124 Rear Window Motor

**Test E**

1E

R070008

**PROBLEM CAUSE**

- Ignition Switch  
*Position: II*

**RESULTS**

BAT VOLT

X141, X162 Rear Window Console Switch

**OK** PROBLEM CAUSE

- WK Wire

**OK**

↓

2E

# L1 ETM

## DISCOVERY

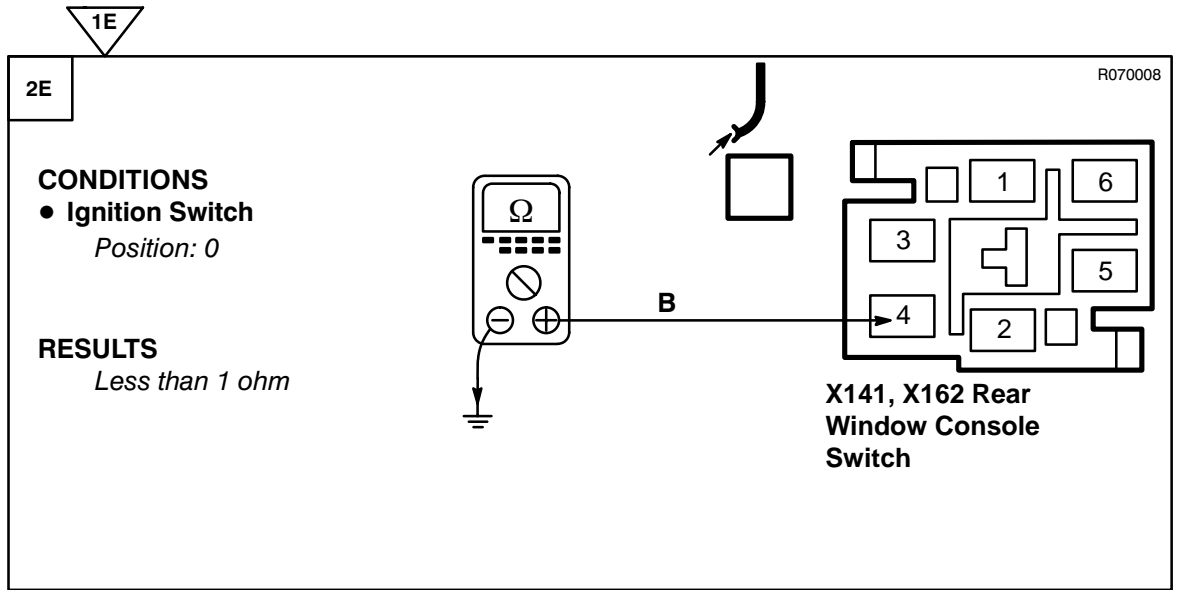

**PROBLEM CAUSE**  
- B Wire



**PROBLEM CAUSE**  
- S, SO Wire  
- SN, SW Wire  
- X141, X162 Rear Window Console Switch

### Test F

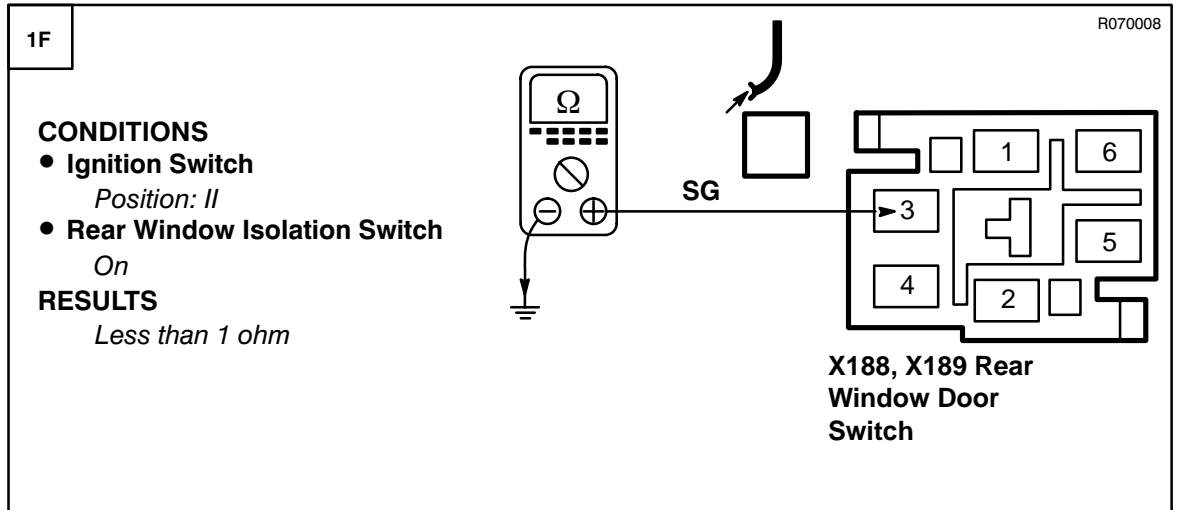

**PROBLEM CAUSE**  
- SG Wire



**PROBLEM CAUSE**  
- X188, X189 Rear Window Door Switch

**Test G**

1G

R100005

**CONDITIONS**

- Ignition Switch  
*Position: 0*

**RESULTS**

- X122, X151 Front Window Switch
  - ⬆ = Less than 1 ohm
  - ⬇ = More than 10K ohms

**Z147**  
Window Lift ECU



GO TO TEST H

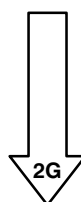

2G

R100005

**CONDITIONS**

- Ignition Switch  
*Position: 0*

**RESULTS**

- X122, X151 Front Window Switch
  - ⬆ = Less than 1 ohm
  - ⬆ = More than 10K ohms

**Z147**  
Window Lift ECU



GO TO TEST H

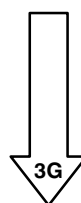

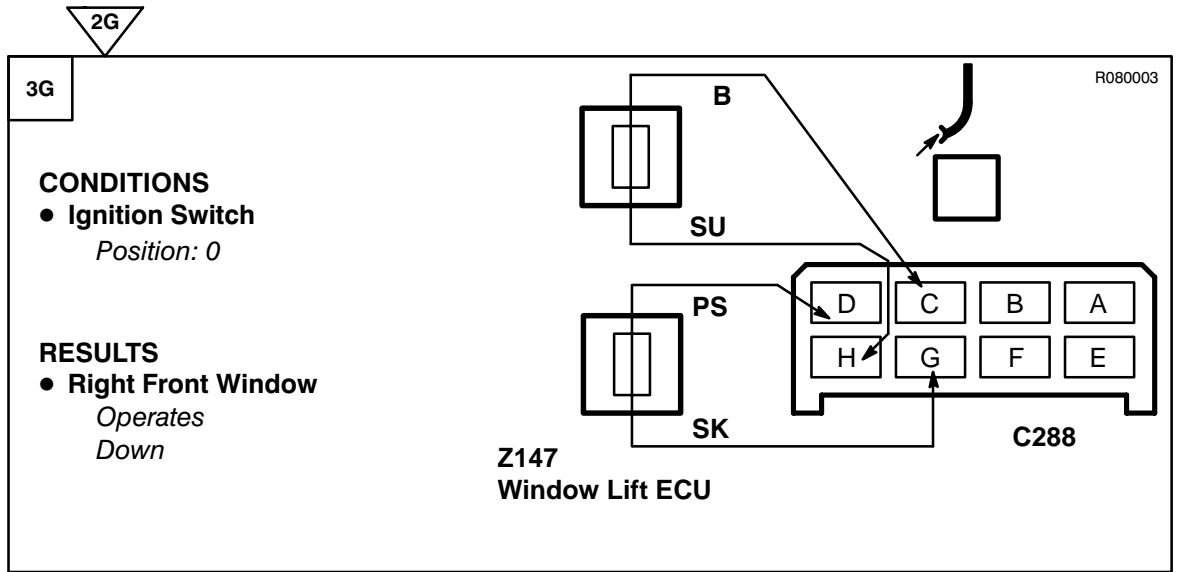

**PROBLEM CAUSE**

- SU Wire
- SK Wire
- Right Front Window Motor

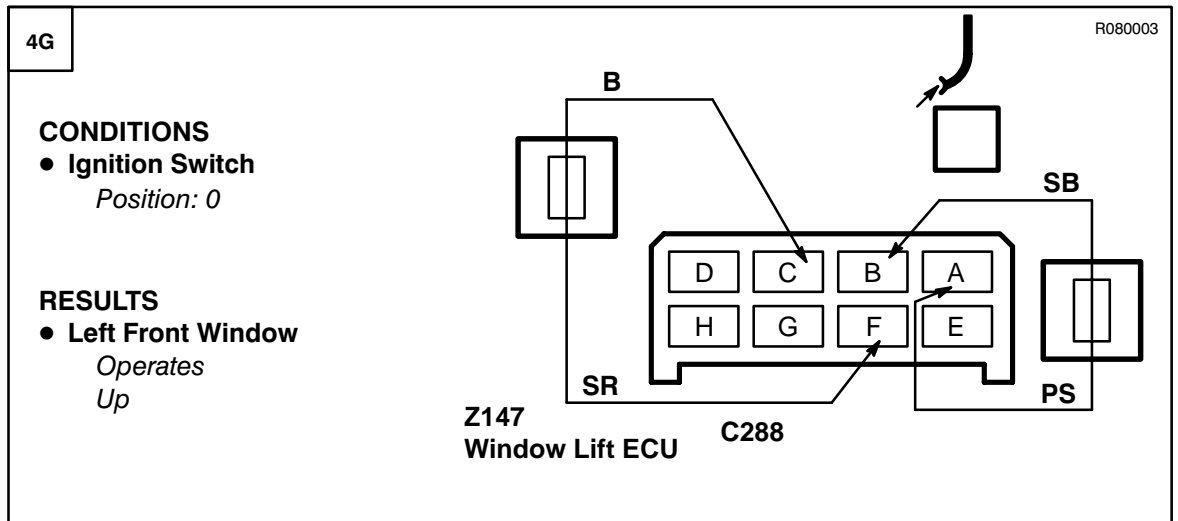
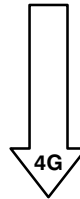

**PROBLEM CAUSE**

- SB Wire
- SR Wire
- Left Front Window Motor



**PROBLEM CAUSE**

- Window Lift ECU

Test H

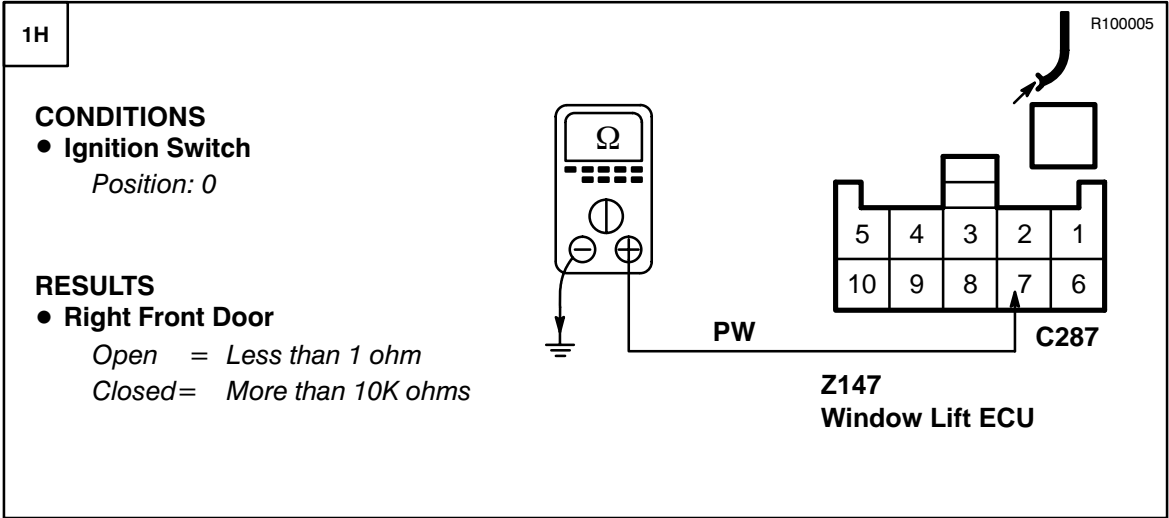

**PROBLEM CAUSE**

- PW Wire
- Right Front Door Switch



**PROBLEM CAUSE**

- Window Lift ECU

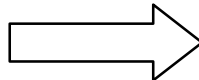
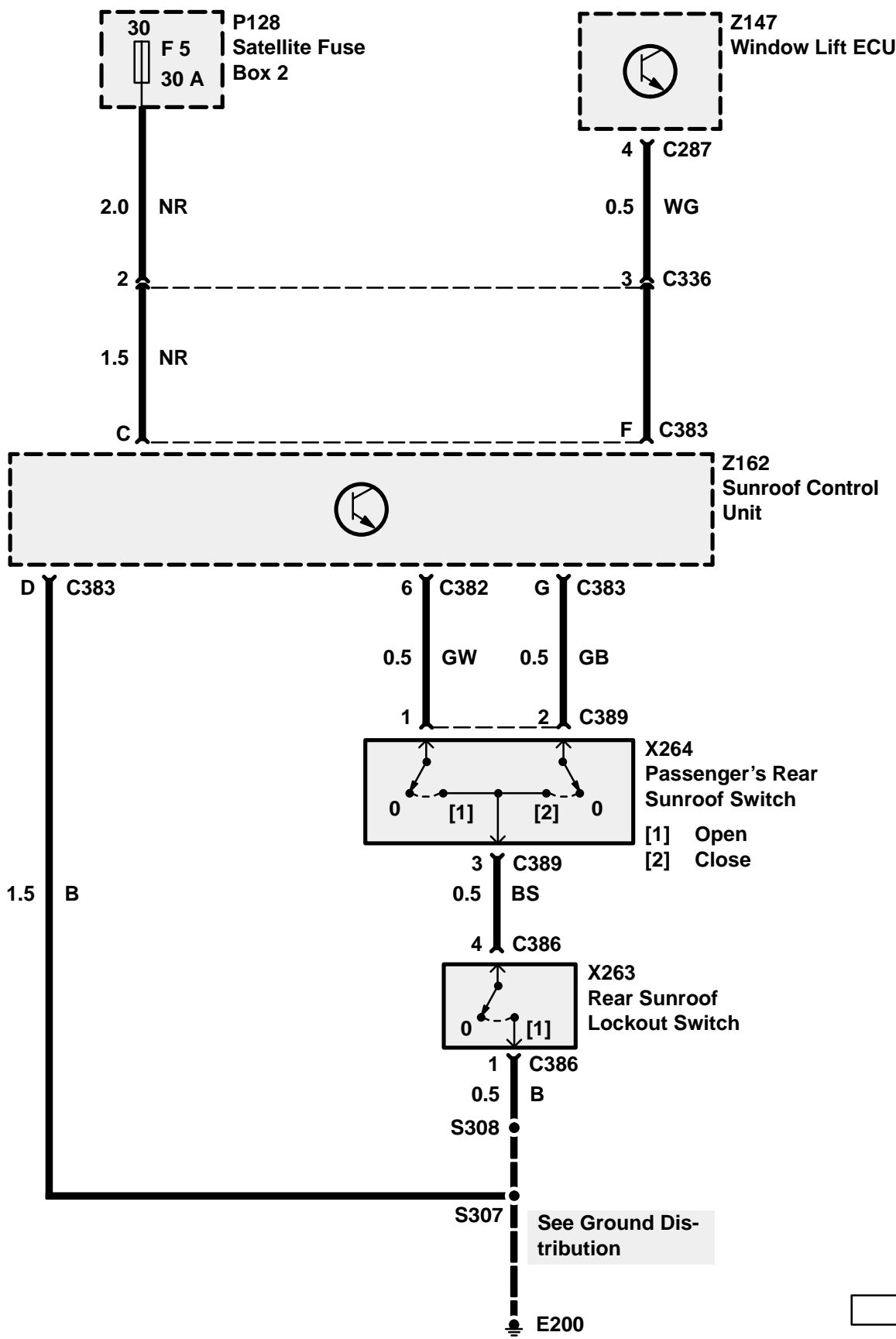

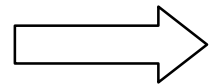
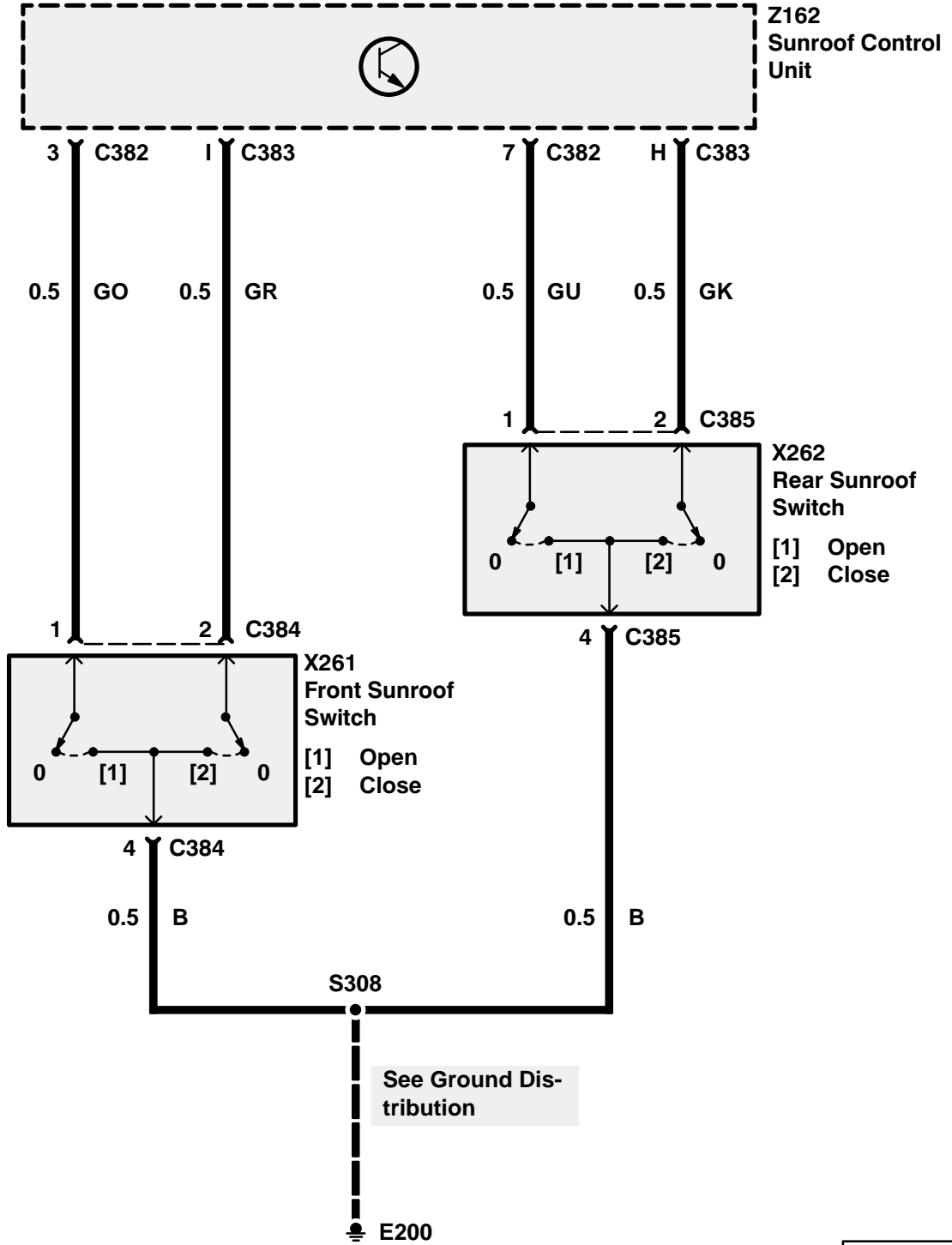
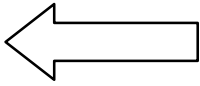



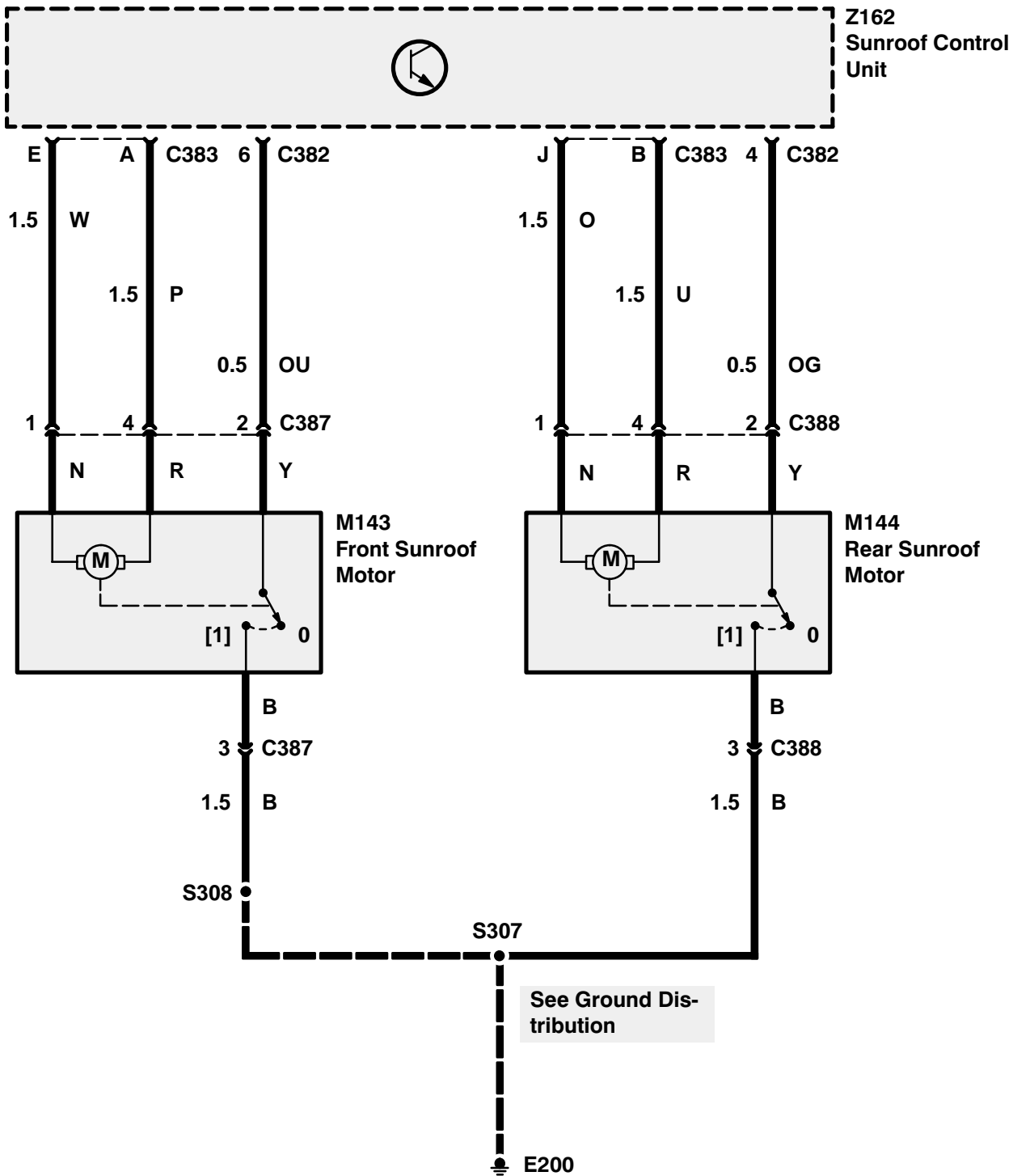
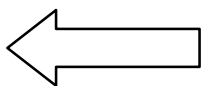

## CIRCUIT OPERATION

The locking functions on models with the Theft Alarm System are controlled by the Theft Alarm Unit (Z163). Refer to the Theft Alarm System (T1). The locking functions on models without the Theft Alarm System are controlled by the Right Front Door Lock Actuator (M122).

The four doors and the tailgate are locked or unlocked using the right front exterior key or the interior door sill knob. The rear doors can be independently locked or unlocked from the inside by using the appropriate door sill knob. These can be overridden when the lock controls in the right front door are used. The left front door and the rear doors may be locked or unlocked in isolation, from the outside using the key or from the inside using the door sill knob.

### Lock

When the doors are locked by the right front exterior key or the interior door sill knob the internal microswitches in the Right Front Door Lock Actuator (M122) move to the "Lock" Position. Voltage from fuse F4 is applied to the lock actuators through the K wires. The lock actuators are grounded at E200 through the microswitch contacts and the O wires. The doors and the tailgate now lock. The solid state load sensor/timer ensure that the motors operate only for the time required to lock or unlock the doors and the tailgate.

### Unlock

When the doors are unlocked by the right front exterior key or the interior door sill knob the internal microswitches in the Right Front Door Lock Actuator (M122) move to the "Unlock" Position. Voltage from Fuse F4 is applied to the lock actuators through the O wires. The lock actuators are grounded at E200 through the microswitch contacts and the K wires. Since the polarity of the voltage is now reversed the doors and the tailgate unlock.

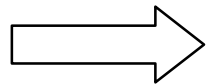
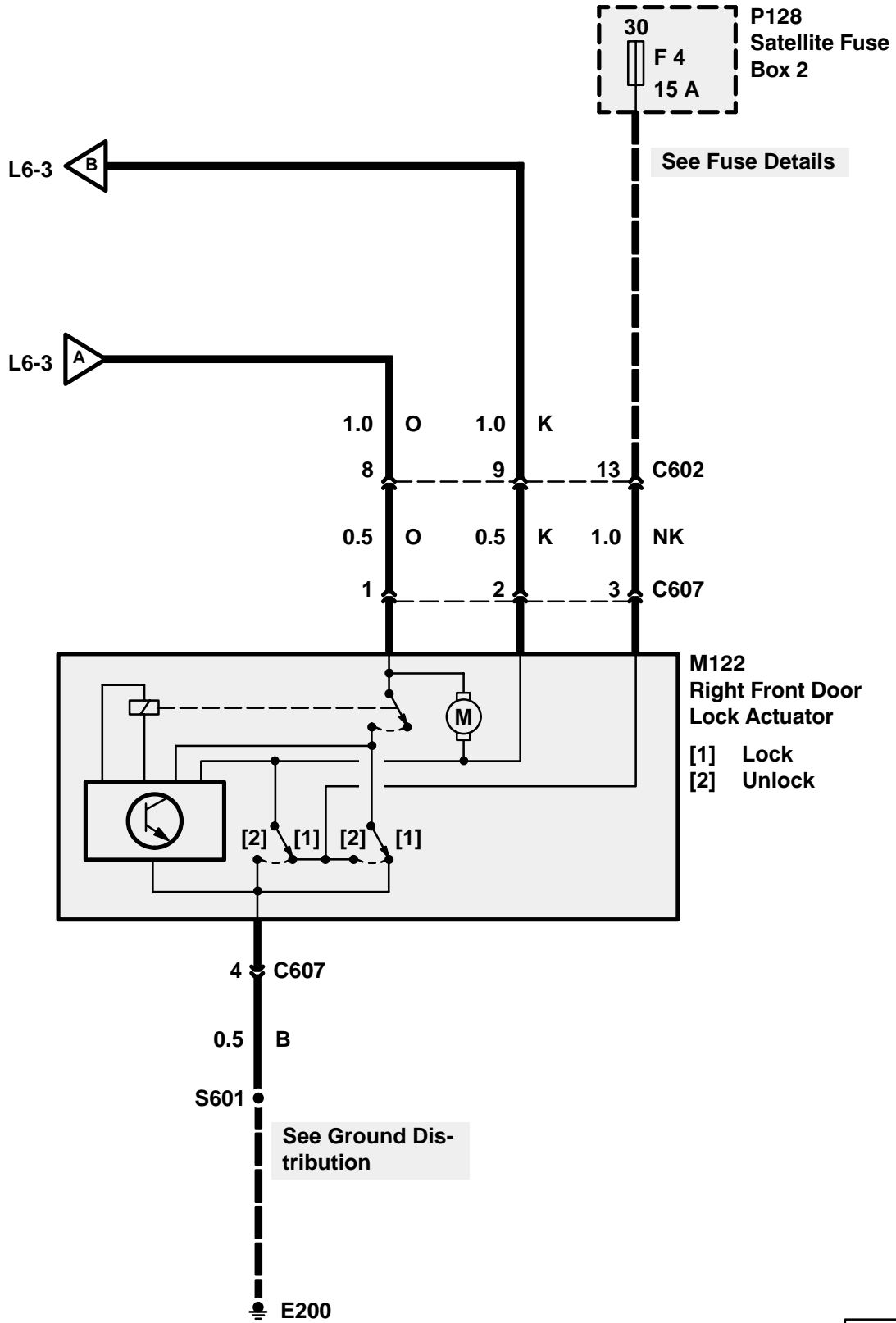

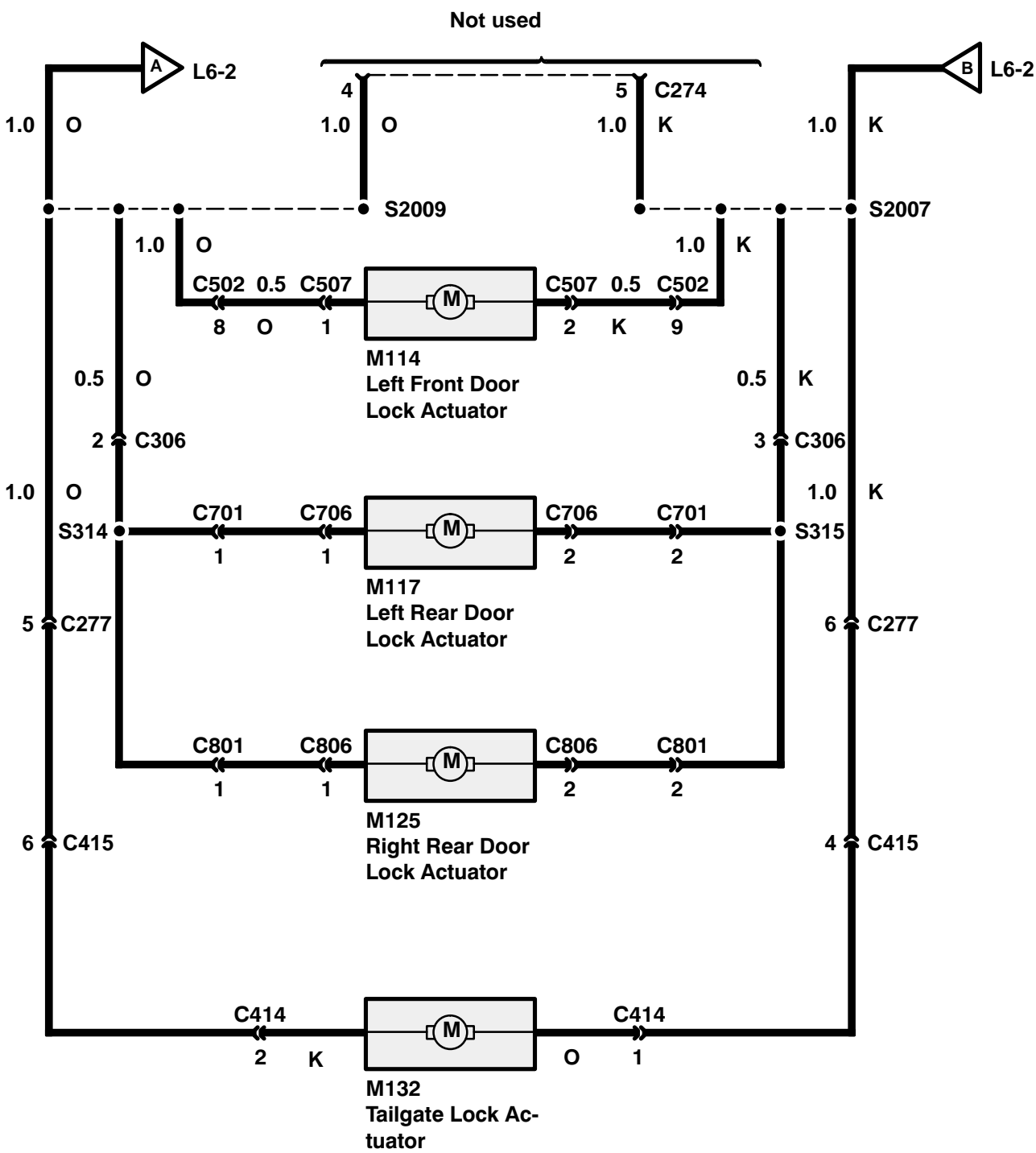
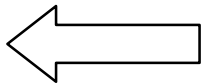

**TROUBLESHOOTING HINTS**

9. Check Fuse F4 of Satellite Fuse Box 2.
10. If all the central locking functions except the right front door operate, replace the Right Front Door Lock Actuator (M122 ).

**SYSTEM DIAGNOSIS**

1. If the central locking functions do not operate at all, do Test A.
2. If the Left Front Door Actuator (M114) does not operate, do Test B.
3. If the Tailgate Lock Actuator (M132) does not operate, do Test C.
4. If both Rear Door Lock Actuators (M117, M125) do not operate, do Test D.

**Test A**

1A

R040011

**CONDITIONS**

- Ignition Switch  
*Position: 0*

**RESULTS**  
*BAT VOLT*

M122  
Right Front Door  
Lock Actuator



**PROBLEM CAUSE**

- F4 Fuse
- NK Wire
- B Wire



**PROBLEM CAUSE**

- Right Front Door  
Lock Actuator

**Test B**

1B

R020053

**CONDITIONS**

- Ignition Switch  
*Position: 0*
- All doors  
*Locked*
- Unlock Right Front Door

**RESULTS**  
*BAT VOLT (Momentary)*

M114  
Left Front Door  
Lock Actuator



**PROBLEM CAUSE**

- O Wire
- K Wire



**PROBLEM CAUSE**

- Left Front Door  
Lock Actuator

### Test C

R020031

1C

**CONDITIONS**

- Ignition Switch  
*Position: 0*
- All doors  
*Unlocked*
- Lock Right Front Door

**RESULTS**  
*BAT VOLT (Momentary)*

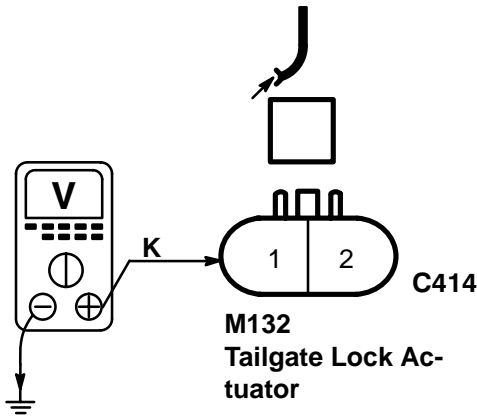

M132  
Tailgate Lock Ac-  
tuator



**PROBLEM CAUSE**  
- K Wire

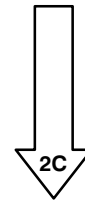

R020031

2C

**CONDITIONS**

- Ignition Switch  
*Position: 0*
- All doors  
*Locked*
- Unlock Right Front Door

**RESULTS**  
*BAT VOLT (Momentary)*

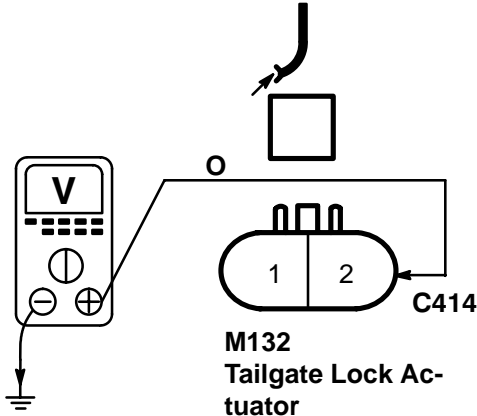

M132  
Tailgate Lock Ac-  
tuator



**PROBLEM CAUSE**  
- O Wire



**PROBLEM CAUSE**  
- Tailgate Lock Actuator

Test D

R020029

1D

**CONDITIONS**

- Ignition Switch  
*Position: 0*
- All doors  
*Unlocked*
- Lock Right Front Door

**RESULTS**  
*BAT VOLT (Momentary)*

M117, M125 Rear Door Lock Actuator  
C706  
C806

~~OK~~ PROBLEM CAUSE  
- K Wire

OK

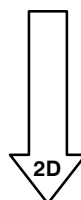

R020029

2D

**CONDITIONS**

- Ignition Switch  
*Position: 0*
- All doors  
*Locked*
- Unlock Right Front Door

**RESULTS**  
*BAT VOLT (Momentary)*

M117, M125 Rear Door Lock Actuator  
C706  
C806

~~OK~~ PROBLEM CAUSE  
- O Wire

OK PROBLEM CAUSE  
- M117, M125 Rear Door Lock Actuator



## CIRCUIT OPERATION

Fuses F1 and F5 supply voltage to the Central Locking Control Unit (Z113). The control unit is grounded at terminal 2 to ground E201.

### Inputs

The Central Locking Control Unit (Z113) monitors the position of the front door locks through input switches that are part of the Front Door Lock Actuators (M114, M122). When the control unit sees an input switch change position, the control unit responds by locking or unlocking the doors and the tailgate.

### Lock

The Central Locking Control Unit (Z113) locks the doors and the tailgate by momentarily applying battery voltage to the actuators through the K wire. The lock actuators are grounded by the Central Locking Control Unit through the O wire. The actuators now move to the locked position.

### Unlock

To unlock the doors and the tailgate the Central Locking Control Unit (Z113) momentarily applies battery voltage to the actuators through the O wire. The actuators are grounded by the Central Locking Control Unit through the K wire. The lock actuators now unlock.

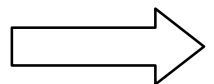
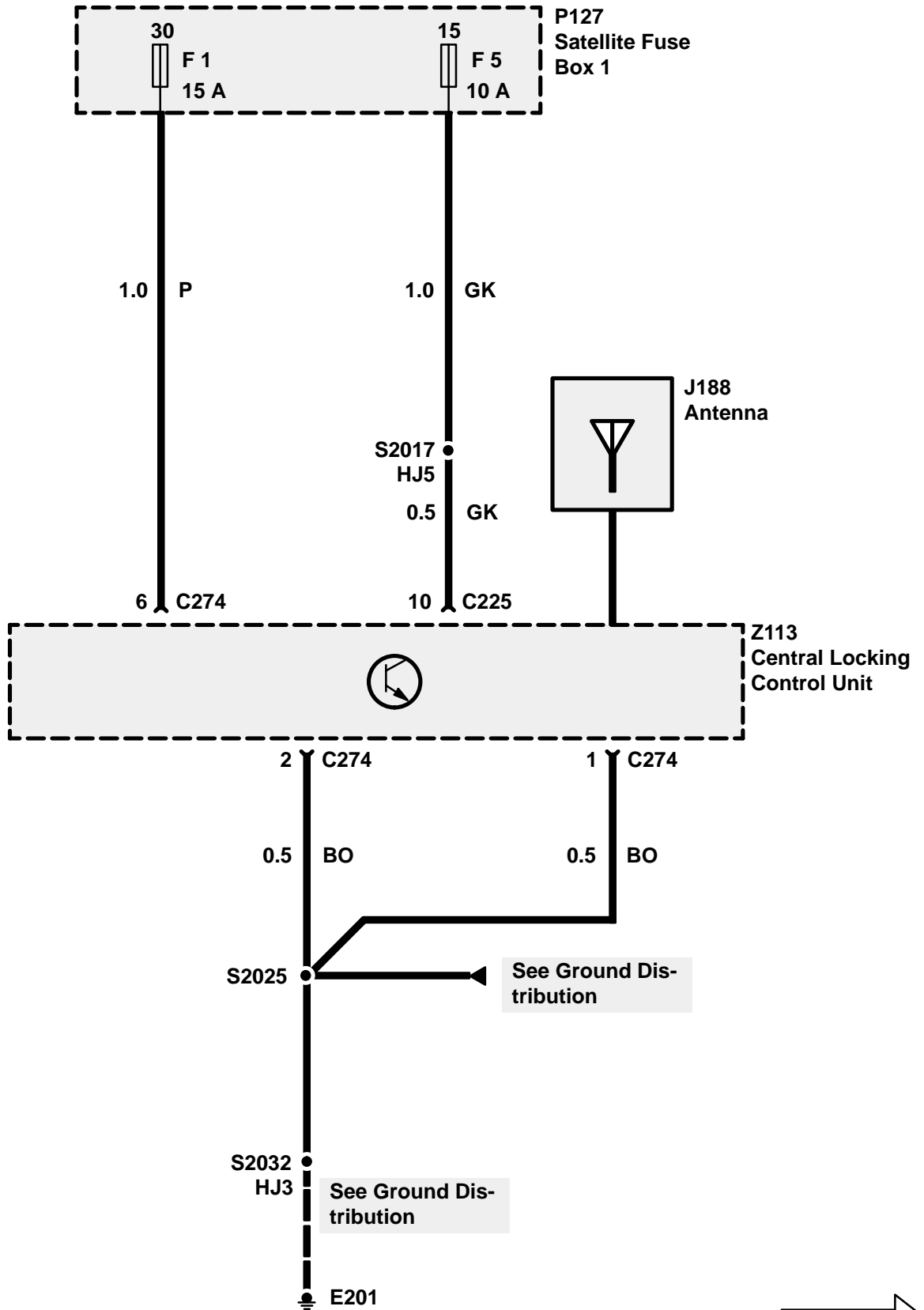

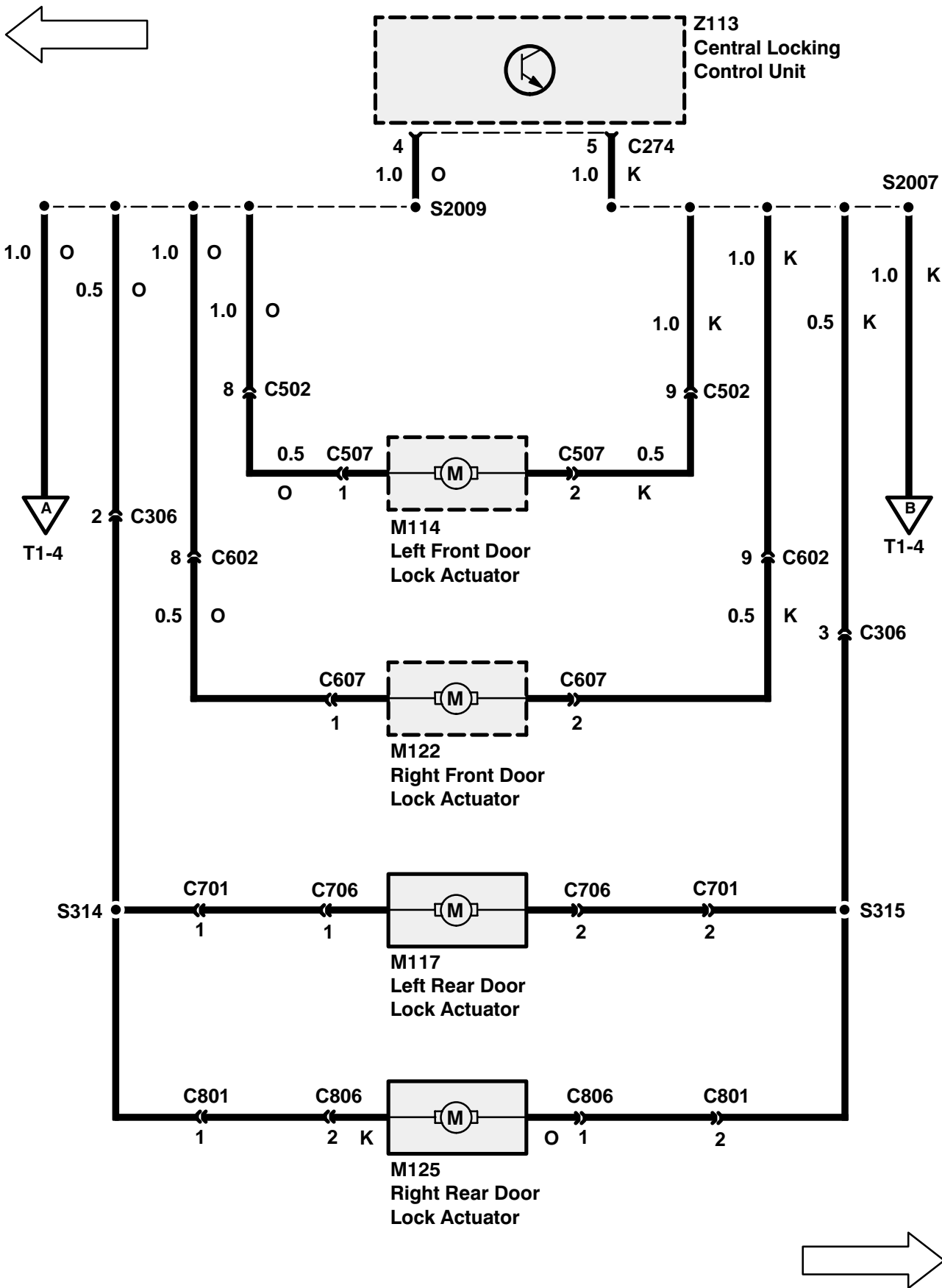

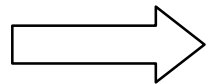
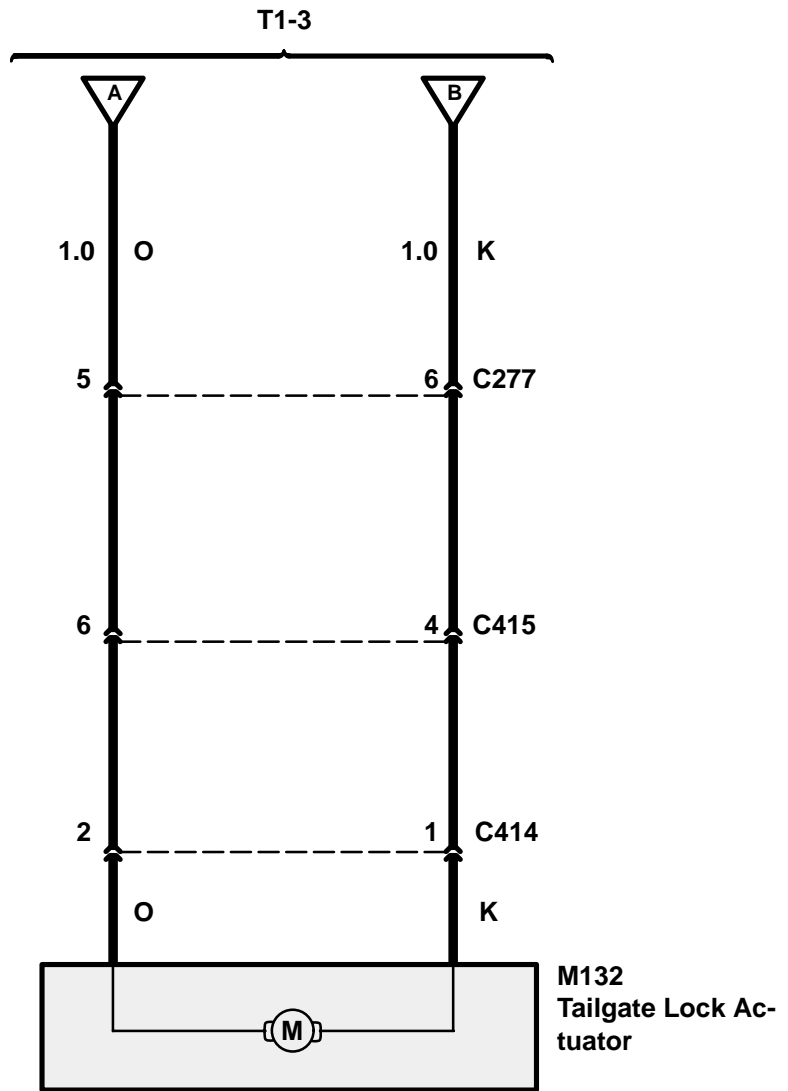
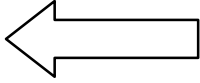

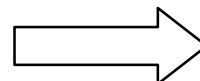
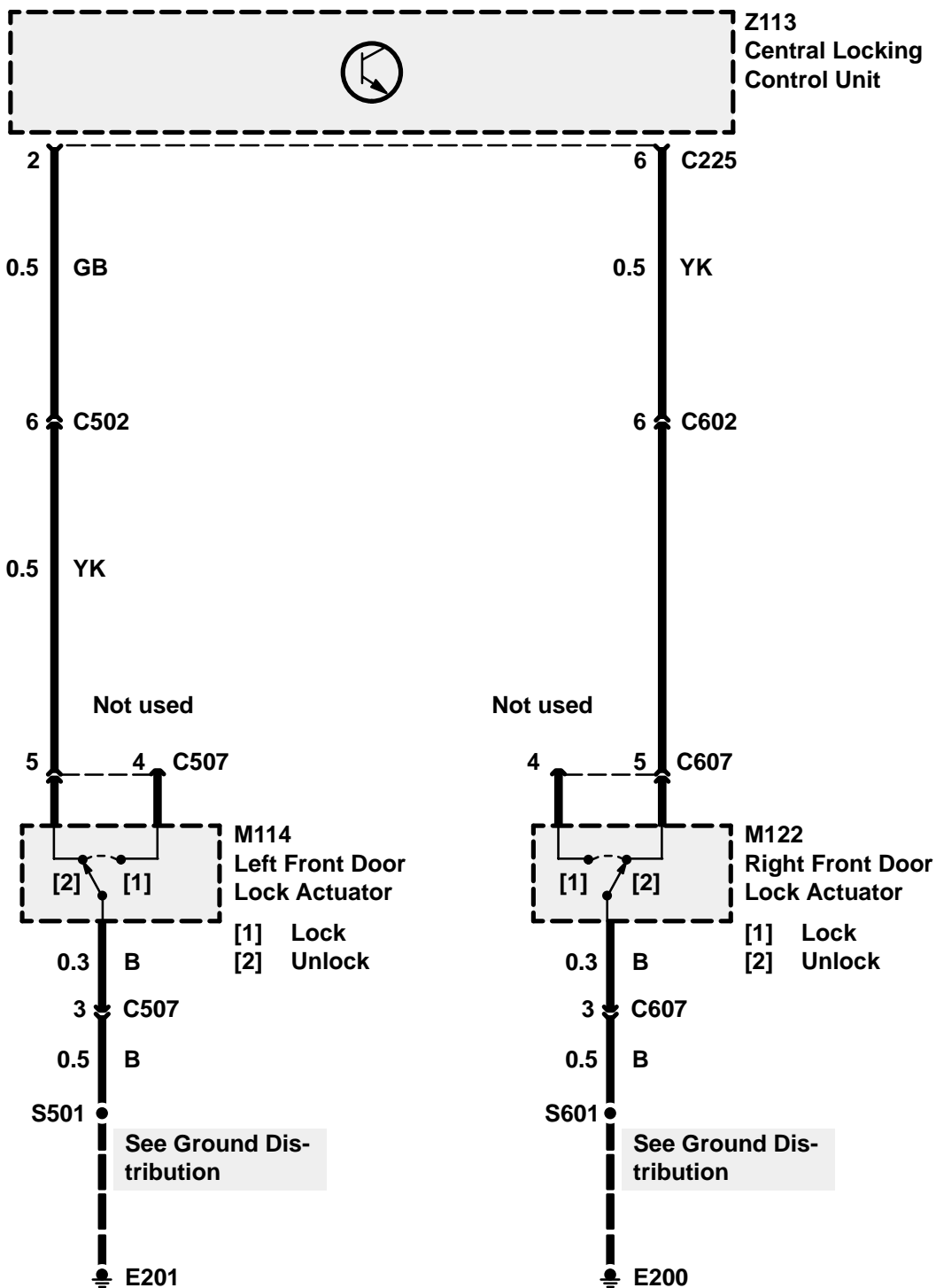
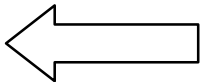

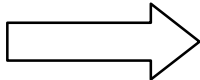
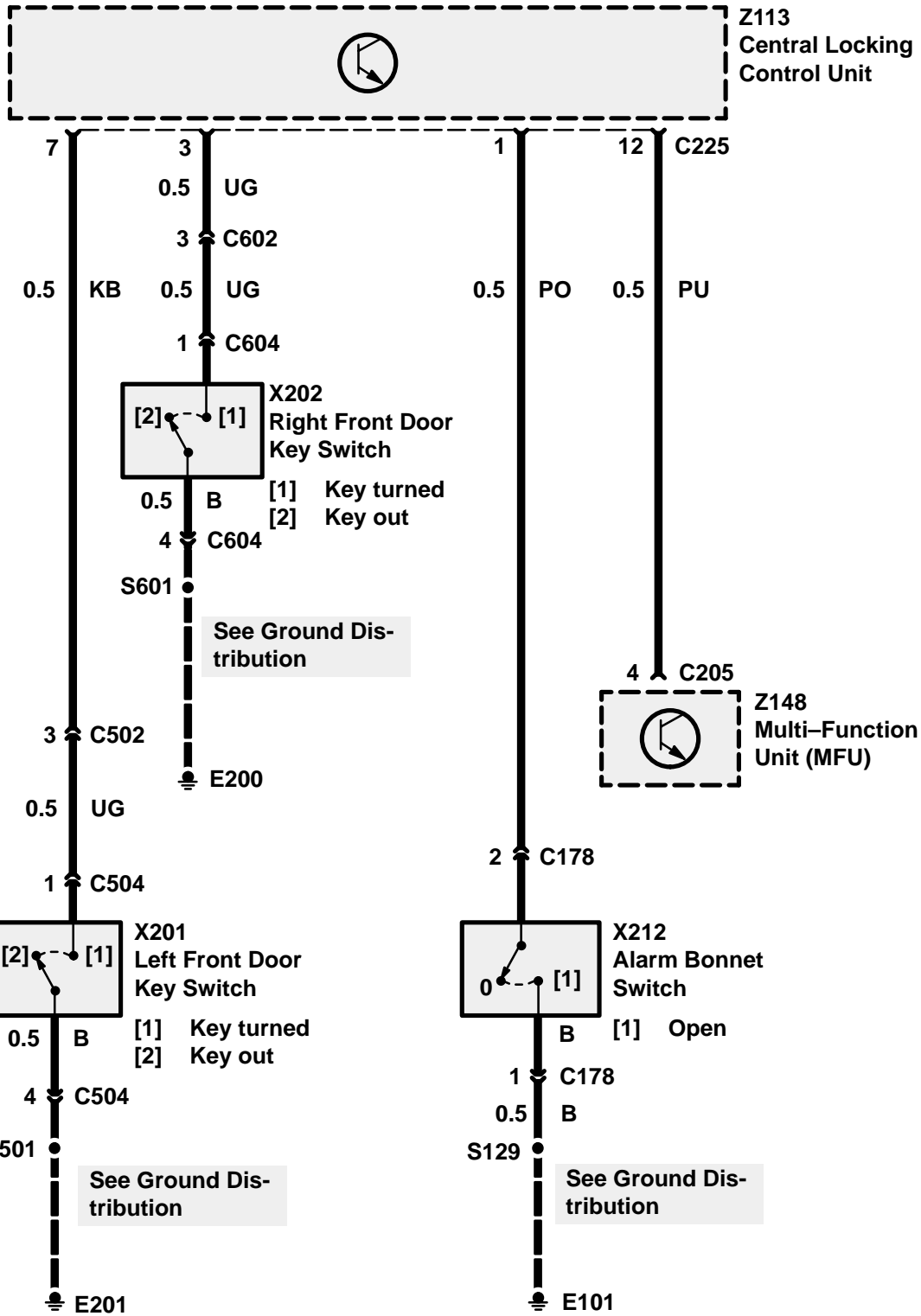

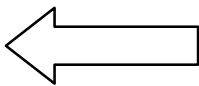

Z113  
Central Locking  
Control Unit

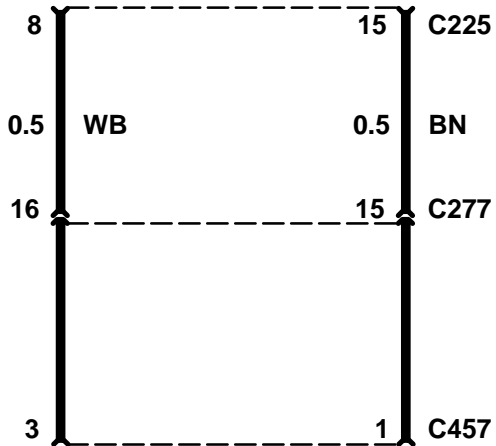

Not used

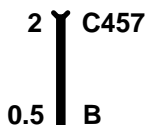

See Ground Dis-  
tribution

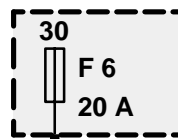

P128  
Satellite Fuse  
Box 2

See Fuse Details

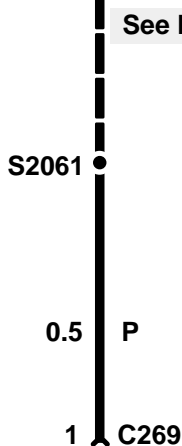

Not used

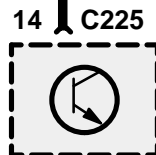
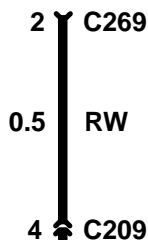

Z113  
Central Locking  
Control Unit



**TROUBLESHOOTING HINTS**

5. Check Fuses F1, F5 in Satellite Fuse Box 1.
6. If the interior lights do not come on when a door is open, check suspect door switch and associated wiring.

**SYSTEM DIAGNOSIS**

1. If the central locking function does not operate at all, do Test A.
2. If a Front Door Lock Actuator (M114, M122) does not operate, do Test B.
3. If the doors unlock themselves after operating the door locks, do Test C.
4. If the central locking function does not operate from one of the front doors, do Test D.
5. If the Tailgate Lock Actuator (M132) does not operate, do Test E.
6. If both Rear Door Lock Actuators (M117, M125) do not operate, do Test F.



**Test A**

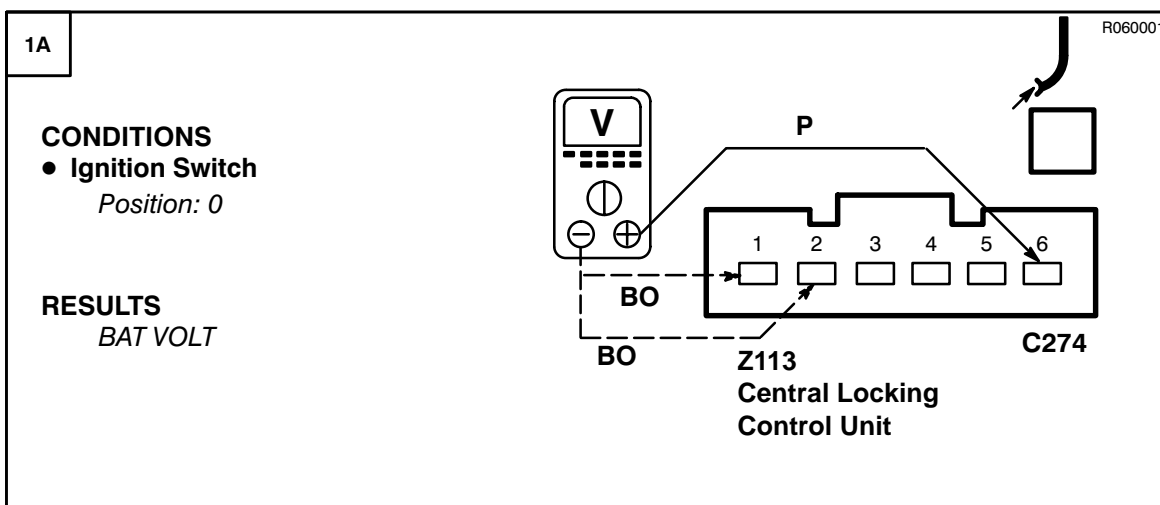

**PROBLEM CAUSE**

- BO Wire
- P Wire

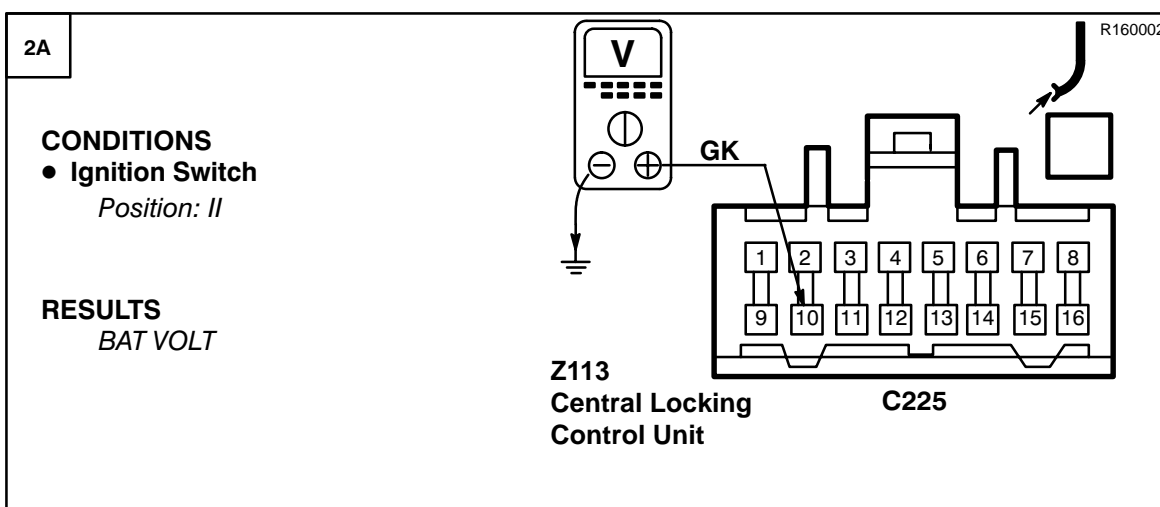
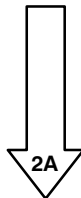

**PROBLEM CAUSE**

- GK Wire



**PROBLEM CAUSE**

- Central Locking  
 Control Unit

### Test B

R060009

1B

**CONDITIONS**

- Ignition Switch  
*Position: II*
- All doors  
*Locked*
- Unlock a front door

**RESULTS**  
*BAT VOLT (Momentary)*

M114, M122 Front Door Lock Actuator

**OK** PROBLEM CAUSE  
- O Wire

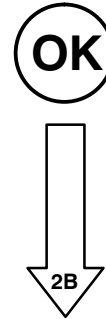

R060009

2B

**CONDITIONS**

- Ignition Switch  
*Position: II*
- All doors  
*Unlocked*
- Lock a front door

**RESULTS**  
*BAT VOLT (Momentary)*

M114, M122 Front Door Lock Actuator

**OK** PROBLEM CAUSE  
- K Wire

**OK** PROBLEM CAUSE  
- M114, M122 Front Door Lock Actuator

**Test C**

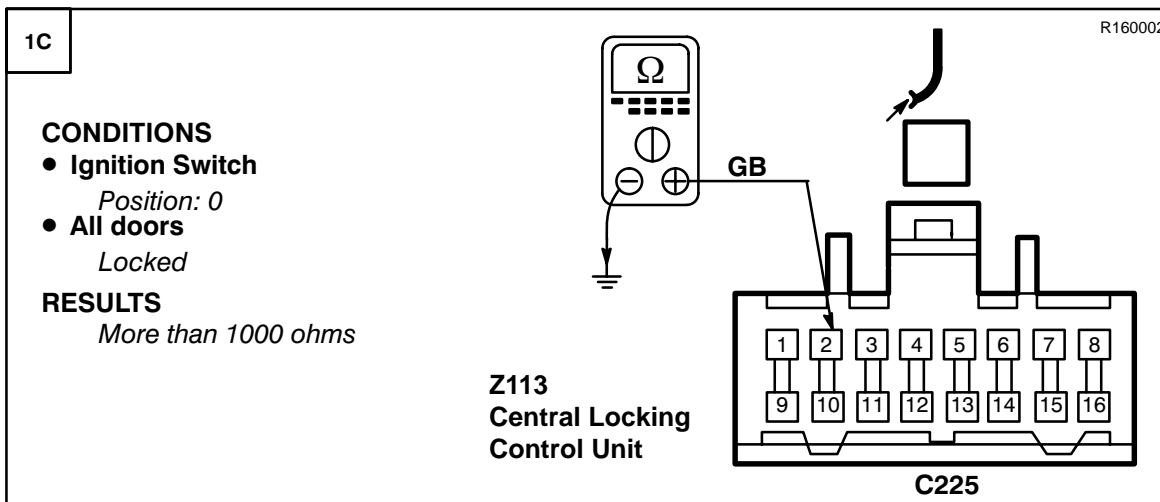

**PROBLEM CAUSE**

- GB, YK Wire
- B Wire
- M114, M122 Front Door Lock Actuator

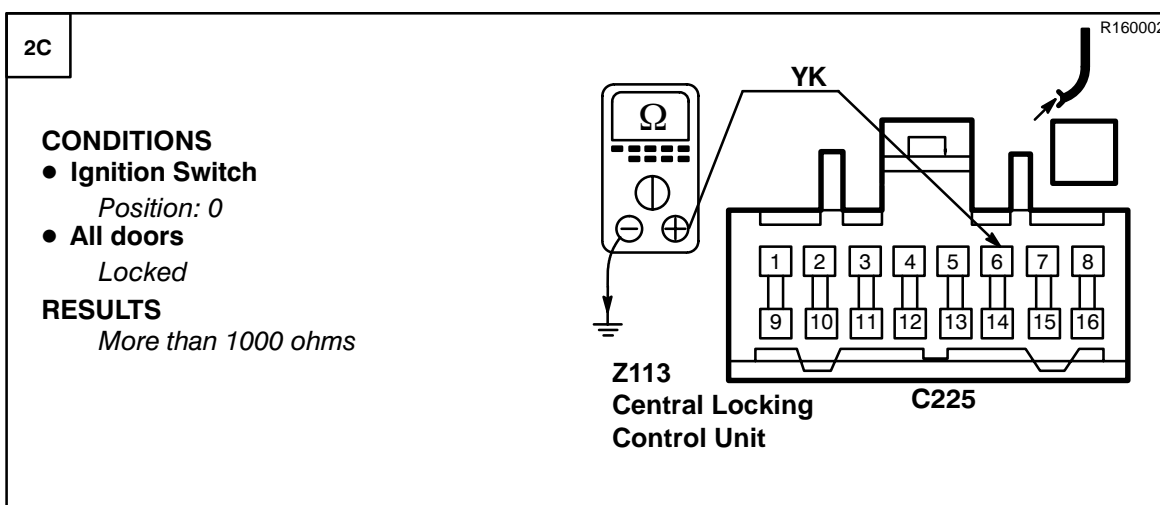
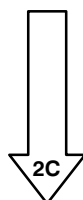

**PROBLEM CAUSE**

- YK Wire
- B Wire
- M114, M122 Front Door Lock Actuator



**PROBLEM CAUSE**

- Central Locking Control Unit

### Test D

R160002

1D

**CONDITIONS**

- Ignition Switch  
*Position: 0*
- All doors  
*Unlocked*

**RESULTS**  
*Less than 1 ohm*

Z113  
Central Locking  
Control Unit

C225



GO TO TEST 3D

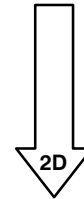

R160002

2D

**CONDITIONS**

- Ignition Switch  
*Position: 0*
- All doors  
*Unlocked*

**RESULTS**  
*Less than 1 ohm*

Z113  
Central Locking  
Control Unit

C225

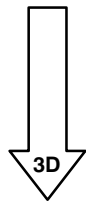

**PROBLEM CAUSE**  
- Central Locking  
Control Unit

R060009

2D
3D

**CONDITIONS**

- Ignition Switch  
*Position: 0*

**RESULTS**

*Less than 1 ohm*

**M114, M122 Front Door Lock Actuator**

C507  
C607

~~OK~~ **PROBLEM CAUSE**  
- B Wire

OK

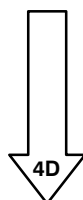

R060009

4D
4D

**CONDITIONS**

- Ignition Switch  
*Position: II*
- All doors  
*Lock*

**RESULTS**

- All doors  
*Unlocked*

**M114, M122 Front Door Lock Actuator**

C507  
C607

~~OK~~ **PROBLEM CAUSE**  
- YK Wire  
- GB (Left)  
- Condenser Fan Coolant Temperature Switch

OK **PROBLEM CAUSE**  
- M114, M122 Front Door Lock Actuator

### Test E

R020029

1E

**CONDITIONS**

- Ignition Switch  
*Position: 0*
- All doors  
*Unlocked*
- Lock a front door

**RESULTS**  
*BAT VOLT (Momentary)*

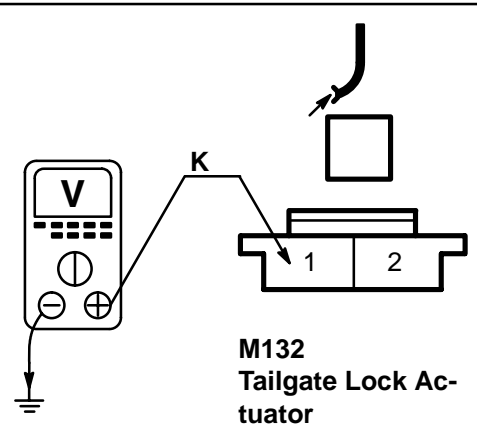

**M132  
Tailgate Lock Ac-  
tuator**

~~OK~~ PROBLEM CAUSE  
- K Wire

OK

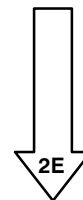

R020029

2E

**CONDITIONS**

- Ignition Switch  
*Position: 0*
- All doors  
*Locked*
- Unlock a front door

**RESULTS**  
*BAT VOLT (Momentary)*

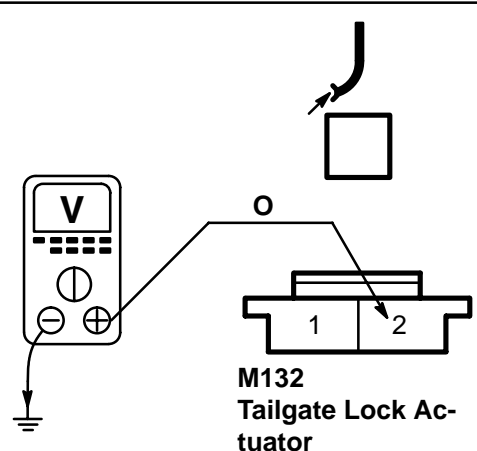

**M132  
Tailgate Lock Ac-  
tuator**

~~OK~~ PROBLEM CAUSE  
- O Wire

OK PROBLEM CAUSE  
- Tailgate Lock Ac-  
tuator

**Test F**

R020029

1F

**CONDITIONS**

- Ignition Switch  
*Position: 0*
- All doors  
*Unlocked*
- Lock a front door

**RESULTS**  
*BAT VOLT (Momentary)*

**M117, M125 Rear Door Lock Actuator**

**OK** PROBLEM CAUSE  
- K Wire

**OK**

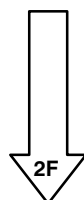

R020029

2F

**CONDITIONS**

- Ignition Switch  
*Position: 0*
- All doors  
*Locked*
- Unlock a front door

**RESULTS**  
*BAT VOLT (Momentary)*

**M117, M125 Rear Door Lock Actuator**

**OK** PROBLEM CAUSE  
- O Wire

**OK** PROBLEM CAUSE  
- M117, M125 Rear Door Lock Actuator

## CIRCUIT OPERATION

When the Ignition Switch (X134) is in Position II, voltage is supplied to the power mirrors circuit by fuse F18.

### Left/Right Movement

When a selected mirror is moved to the left by the Mirror Adjustment Switch (X146) the internal contacts move to the "Move Down or Left" and the "Move Left" Positions. The Left/Right Motor of the selected actuator is grounded at E200 through the SW wires and the switch contacts. Voltage is applied to the Left/Right Motor through the BP, BU wires. The mirror now moves left.

When a selected mirror is moved to the right by the Mirror Adjustment Switch (X146) the internal contacts move to the "Move Up or Right" and the "Move Right" positions. The Left/Right Motor of the selected actuator is grounded at E200 through the BU, BP wires and the switch contacts. Voltage is applied to the Left/Right Motor through the SW wires. Since the polarity of the voltage to the motor has been reversed, the mirror now moves right.

### Up/Down Movement

When a selected mirror is moved down by the Mirror Adjustment Switch (X146) the internal contacts move to the "Move Down or Left" and the "Move Down" positions. The Up/Down Motor of the selected actuator is grounded at E200 through the SW wires and the switch contacts. Voltage is applied to the Up/Down Motor through the BK, BN wires. The mirror now moves down.

When a selected mirror is moved Up by the Mirror Adjustment Switch (X146) the internal contacts move to the "Move Up or Right" and the "Move Up" positions. The Up/Down Motor of the selected actuator is grounded at E200 through the BN, BK wires and the switch contacts. Voltage is applied to the Up/Down Motor through the SW wires. Since the polarity of the voltage to the motor has been reversed, the mirror now moves up.



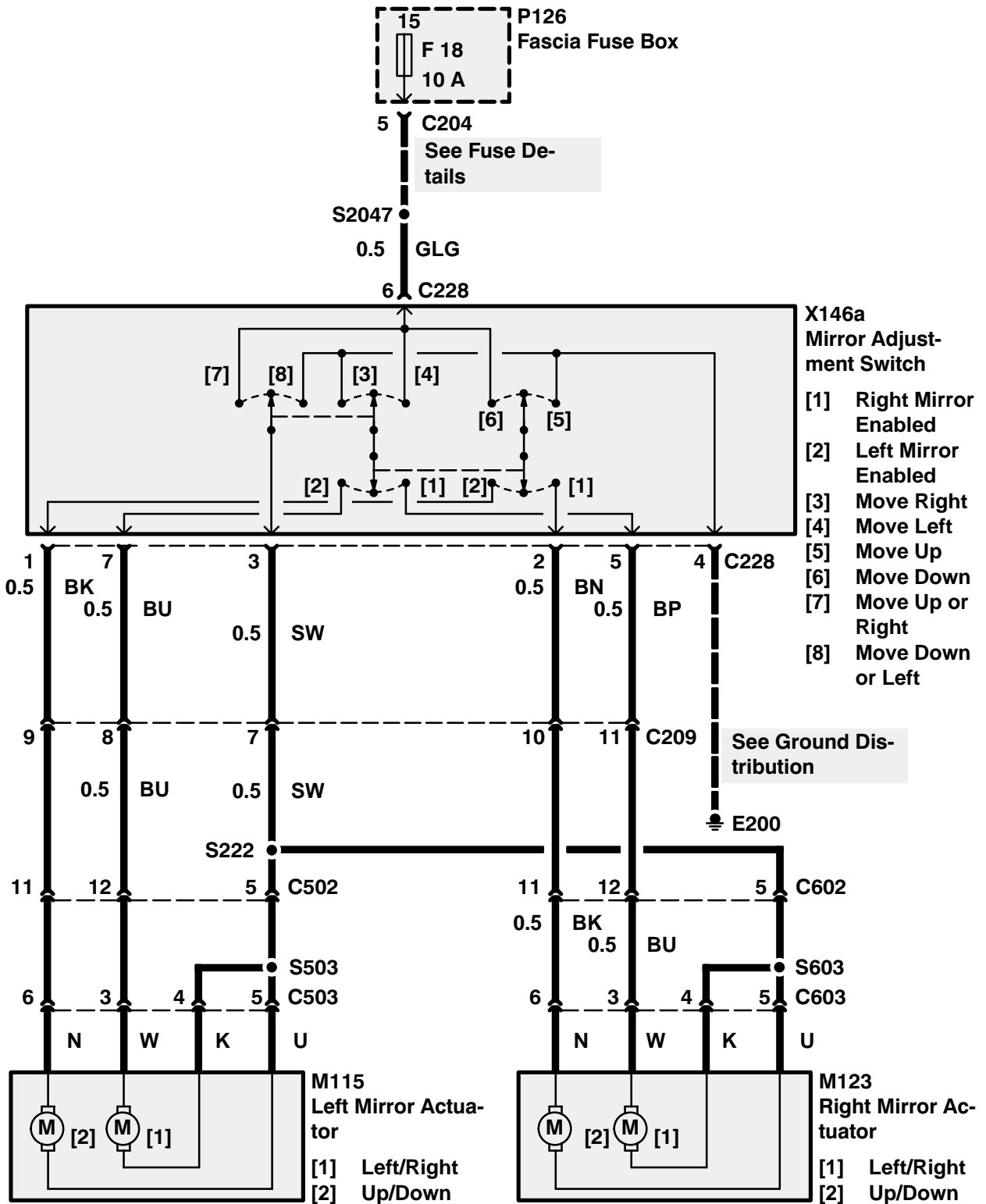

**SYSTEM DIAGNOSIS**

1. If the mirrors do not operate at all, do Test A.
2. If only one mirror does not operate, do test B, the Mirror Actuator (M115, M123) test.
3. If one or both mirrors operate in some, but not all, switch positions do Test A.

Test A

R080015

1A

**CONDITIONS**

- Ignition Switch  
*Position: II*

**RESULTS**  
*BAT VOLT*

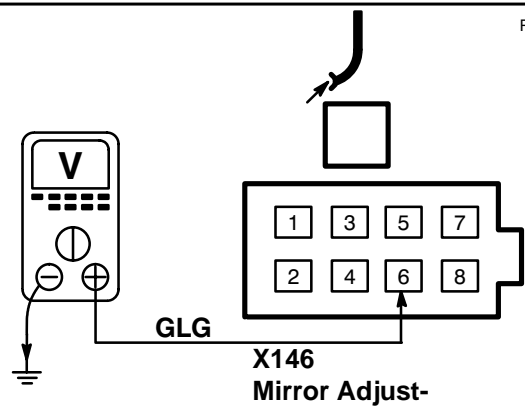

**X146  
Mirror Adjust-  
ment Switch**



**PROBLEM CAUSE**

- F18 Fuse
- GLG Wire

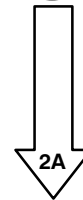

R080015

2A

**CONDITIONS**

- Ignition Switch  
*Position: II*

**RESULTS**  
*Less than 1 ohm*

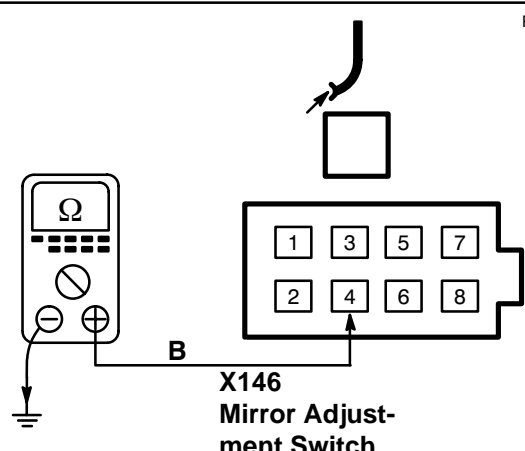

**X146  
Mirror Adjust-  
ment Switch**



**PROBLEM CAUSE**

- B Wire
- Ground Connections

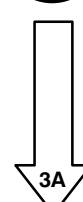

R060008

**2A**

**3A**

**CONDITIONS**

- Ignition Switch  
*Position: II*

**RESULTS**

- Mirror Adjustment Switch  
*Move Up or Right*  
*BAT VOLT*  
*Neutral*  
*0V*

**OK** PROBLEM CAUSE

- SW Wire
- Mirror Adjust-ment Switch

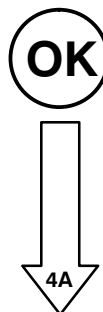

R060008

**4A**

**CONDITIONS**

- Ignition Switch  
*Position: II*

**RESULTS**

- Mirror Adjustment Switch  
*Move Down or Left*  
*Less than 1 ohm*  
*Neutral*  
*More than 10K ohms*

**OK** PROBLEM CAUSE

- Mirror Adjust-ment Switch

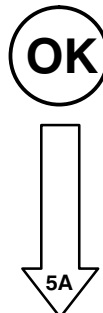

# M3 ETM

## DISCOVERY

R060008

4A

5A

**CONDITIONS**

- Ignition Switch  
*Position: II*
- Mirror Adjustment Switch  
*Right Mirror Enabled*

**RESULTS**

- Mirror Adjustment Switch  
*Left*  
BAT VOLT
- Neutral*  
0V

C603

M123  
Right Mirror Ac-  
tuator



**PROBLEM CAUSE**

- BP, BU Wire
- Mirror Adjust-  
ment Switch

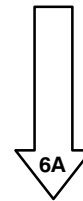

R060008

6A

6A

**CONDITIONS**

- Ignition Switch  
*Position: II*
- Mirror Adjustment Switch  
*Right Mirror Enabled*

**RESULTS**

- Mirror Adjustment Switch  
*Right*  
Less than 1 ohm
- Neutral*  
More than 10K ohms

C603

M123  
Right Mirror Ac-  
tuator



**PROBLEM CAUSE**

- Mirror Adjust-  
ment Switch

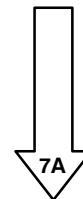

R060008

6A

7A

**CONDITIONS**

- Ignition Switch  
*Position: II*
- Mirror Adjustment Switch  
*Right Mirror Enabled*

**RESULTS**

- Mirror Adjustment Switch  
*Down*  
BAT VOLT  
*Neutral*  
0V

C603

M123  
Right Mirror Ac-  
tuator



**PROBLEM CAUSE**

- BN,BK Wire
- Mirror Adjust-  
ment Switch

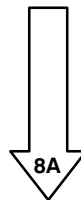

R060008

8A

**CONDITIONS**

- Ignition Switch  
*Position: II*
- Mirror Adjustment Switch  
*Right Mirror Enabled*

**RESULTS**

- Mirror Adjustment Switch  
*Up*  
Less than 1 ohm  
*Neutral*  
More than 10K ohms

C603

M123  
Right Mirror Ac-  
tuator



**PROBLEM CAUSE**

- Mirror Adjust-  
ment Switch

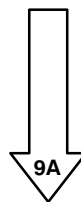

# M3 ETM

## DISCOVERY

R060008

8A

9A

**CONDITIONS**

- Ignition Switch  
*Position: II*
- Mirror Adjustment Switch  
*Left Mirror Enabled*

**RESULTS**

- Mirror Adjustment Switch  
*Left*  
*BAT VOLT*  
*Neutral*  
*0V*

BU

1	2	3
4	5	6

**M115**  
**Left Mirror Actuator**

**C503**



**PROBLEM CAUSE**

- BU Wire
- Mirror Adjustment Switch

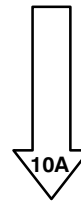

R060008

10A

**CONDITIONS**

- Ignition Switch  
*Position: II*
- Mirror Adjustment Switch  
*Left Mirror Enabled*

**RESULTS**

- Mirror Adjustment Switch  
*Right*  
*Less than 1 ohm*  
*Neutral*  
*More than 10K ohms*

BU

1	2	3
4	5	6

**M115**  
**Left Mirror Actuator**

**C503**



**PROBLEM CAUSE**

- Mirror Adjustment Switch

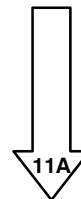

R060008

10A

11A

**CONDITIONS**

- Ignition Switch  
*Position: II*
- Mirror Adjustment Switch  
*Left Mirror Enabled*

**RESULTS**

- Mirror Adjustment Switch  
*Down*  
BAT VOLT
- Mirror Adjustment Switch  
*Neutral*  
0V

C503

M115  
Left Mirror Actuator

~~OK~~ PROBLEM CAUSE

- BK Wire
- Mirror Adjustment Switch

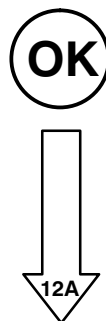

R060008

12A

**CONDITIONS**

- Ignition Switch  
*Position: II*
- Mirror Adjustment Switch  
*Left Mirror Enabled*

**RESULTS**

- Mirror Adjustment Switch  
*Up*  
Less than 1 ohm
- Mirror Adjustment Switch  
*Neutral*  
More than 10K ohms

C503

M115  
Left Mirror Actuator

~~OK~~ PROBLEM CAUSE

- Mirror Adjustment Switch

OK PROBLEM CAUSE

- M115, M123 Mirror Actuator



### Test B

R060008

1B

**CONDITIONS**

- Ignition Switch  
*Position: II*
- Mirror Adjustment Switch  
*Select suspect mirror*

**RESULTS**

- Mirror Adjustment Switch  
*Move Up or Right*  
BAT VOLT  
*Move Down or Left*  
0V

M115, M123 Mirror Actuator



**PROBLEM CAUSE**

- SW Wire
- Mirror Adjustment Switch

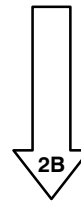

R060008

2B

**CONDITIONS**

- Ignition Switch  
*Position: II*
- Mirror Adjustment Switch  
*Select suspect mirror*

**RESULTS**

- Mirror Adjustment Switch  
*Left*  
BAT VOLT  
*Right*  
0V

M115, M123 Mirror Actuator



**PROBLEM CAUSE**

- BP, BU Wire
- Mirror Adjustment Switch

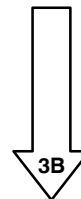

2B
R060008

3B

**CONDITIONS**

- Ignition Switch  
*Position: II*
- Mirror Adjustment Switch  
*Select suspect mirror*

**RESULTS**

- Mirror Adjustment Switch  
*Down*  
BAT VOLT
- Up*  
0V



**PROBLEM CAUSE**

- BK, BN Wire
- Mirror Adjustment Switch



**PROBLEM CAUSE**

- M115, M123 Mirror Actuator

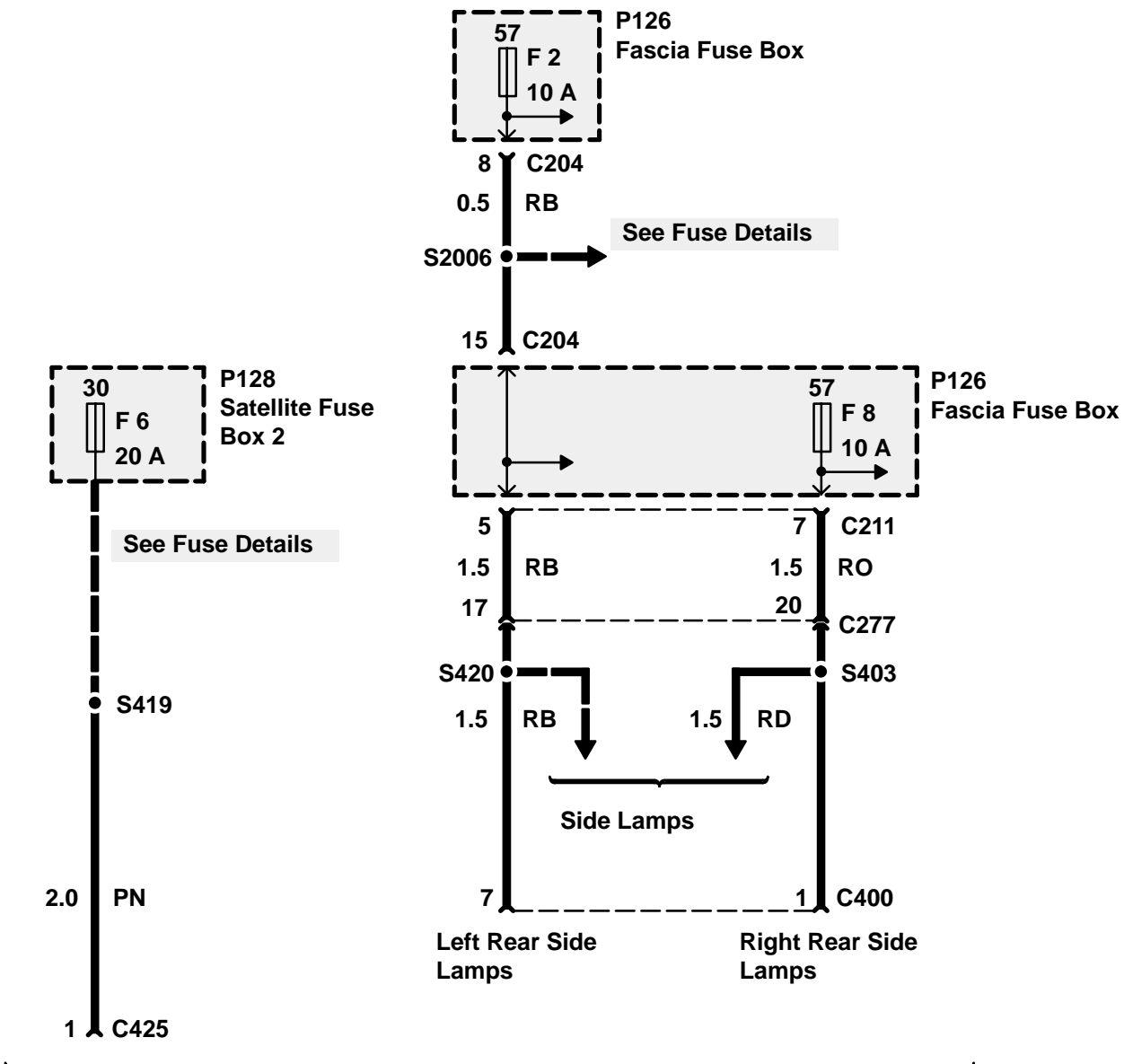

X172  
Trailer Auxiliary  
Socket

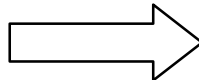
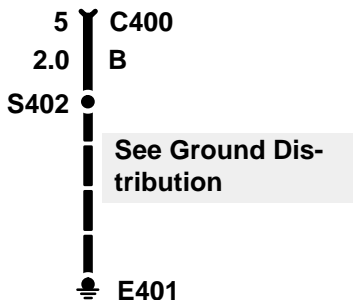

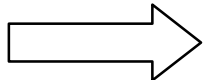
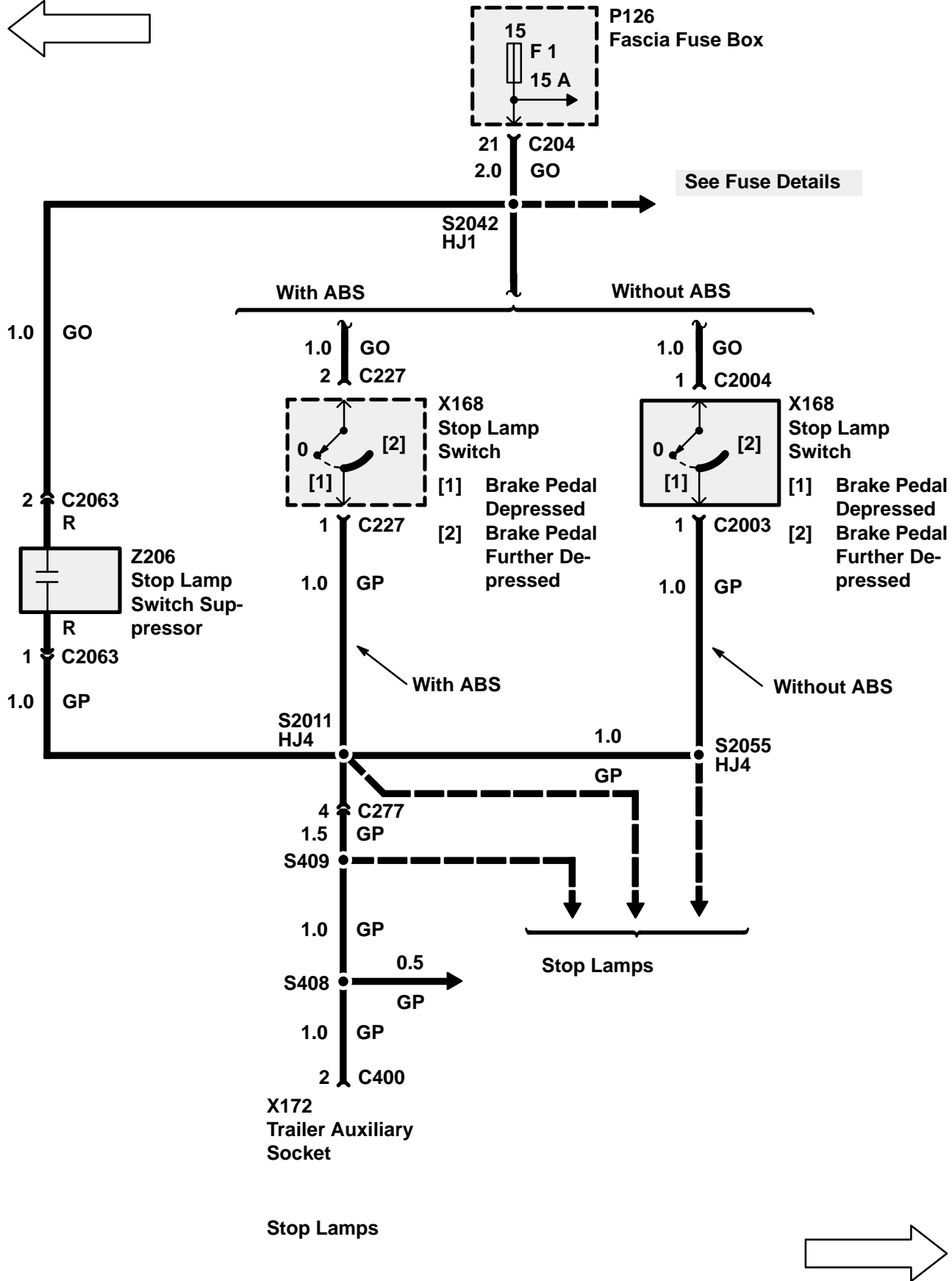
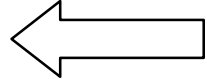

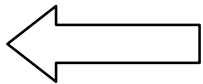

Interior Lamps

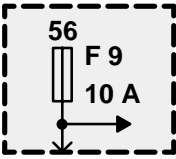

P126 Fascia Fuse Box

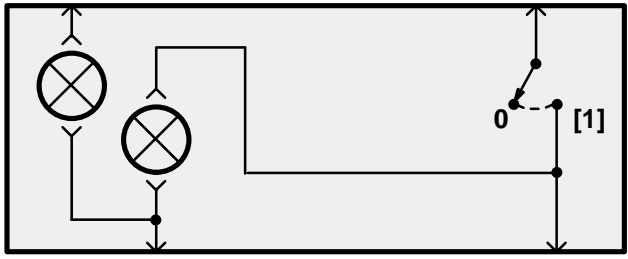
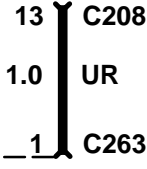
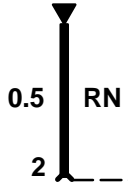

X154 Rear Fog Guard Lamps Switch

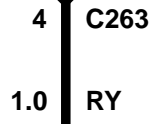

S2059

See Ground Distribution

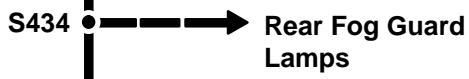
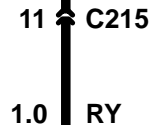

E200



Rear Fog Lamps

X172 Trailer Auxiliary Socket

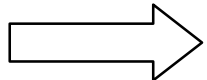

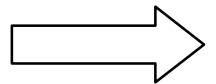
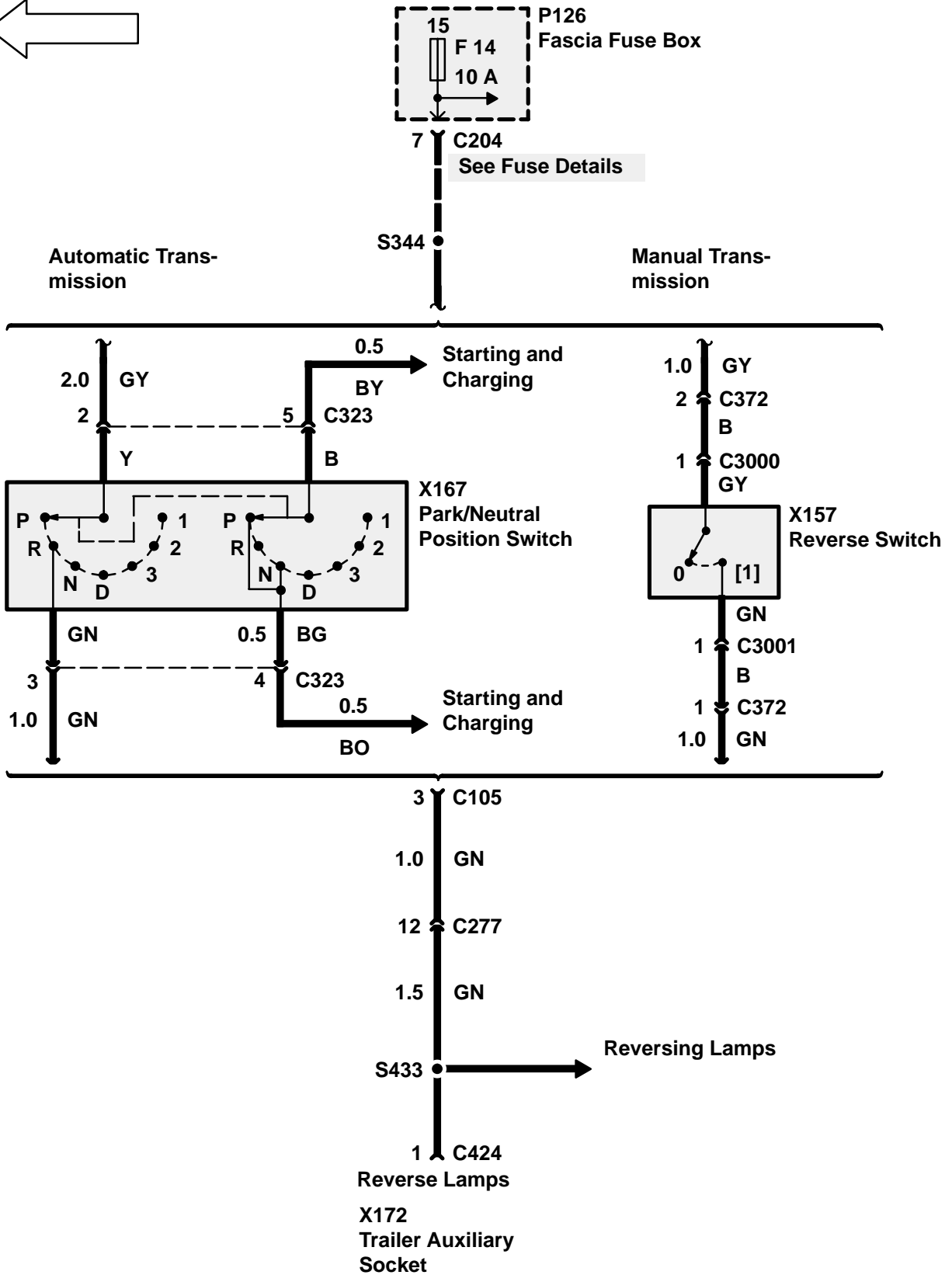
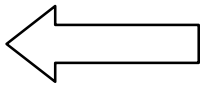

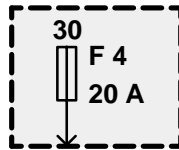
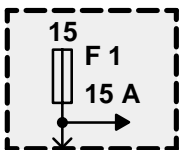
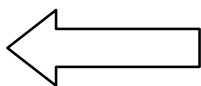

21 C204

4 C101

14 C209  
1.0 GO

1 C215  
1.5 PN

6 7 C267

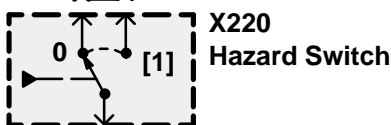

8 C267  
1.0 LGP  
5 C215  
1.5 LGP  
1 C204

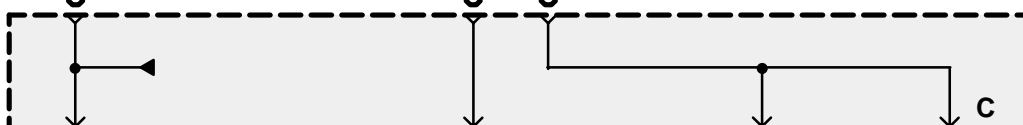
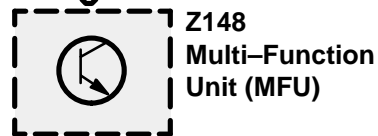
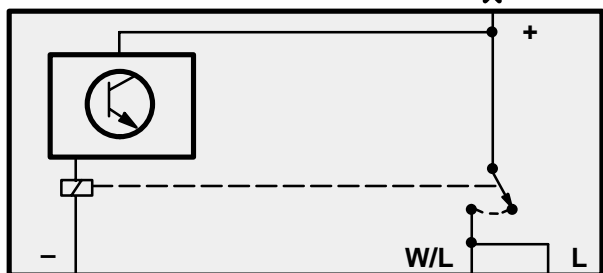
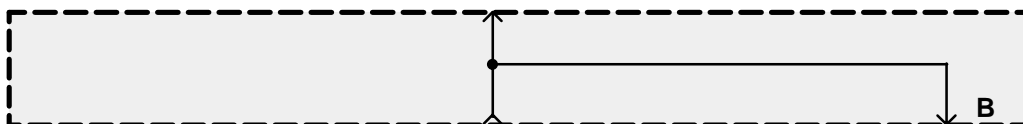

31 C206  
0.5 B

1 C254  
0.5 LGU

2 C204  
1.5 LGN  
B  
P1-6

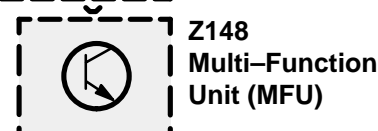

Direction Indicator Lamps

S2016 HJ10

See Ground Distribution

E200

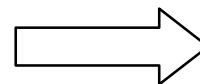

# P1 ETM

## DISCOVERY

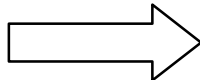
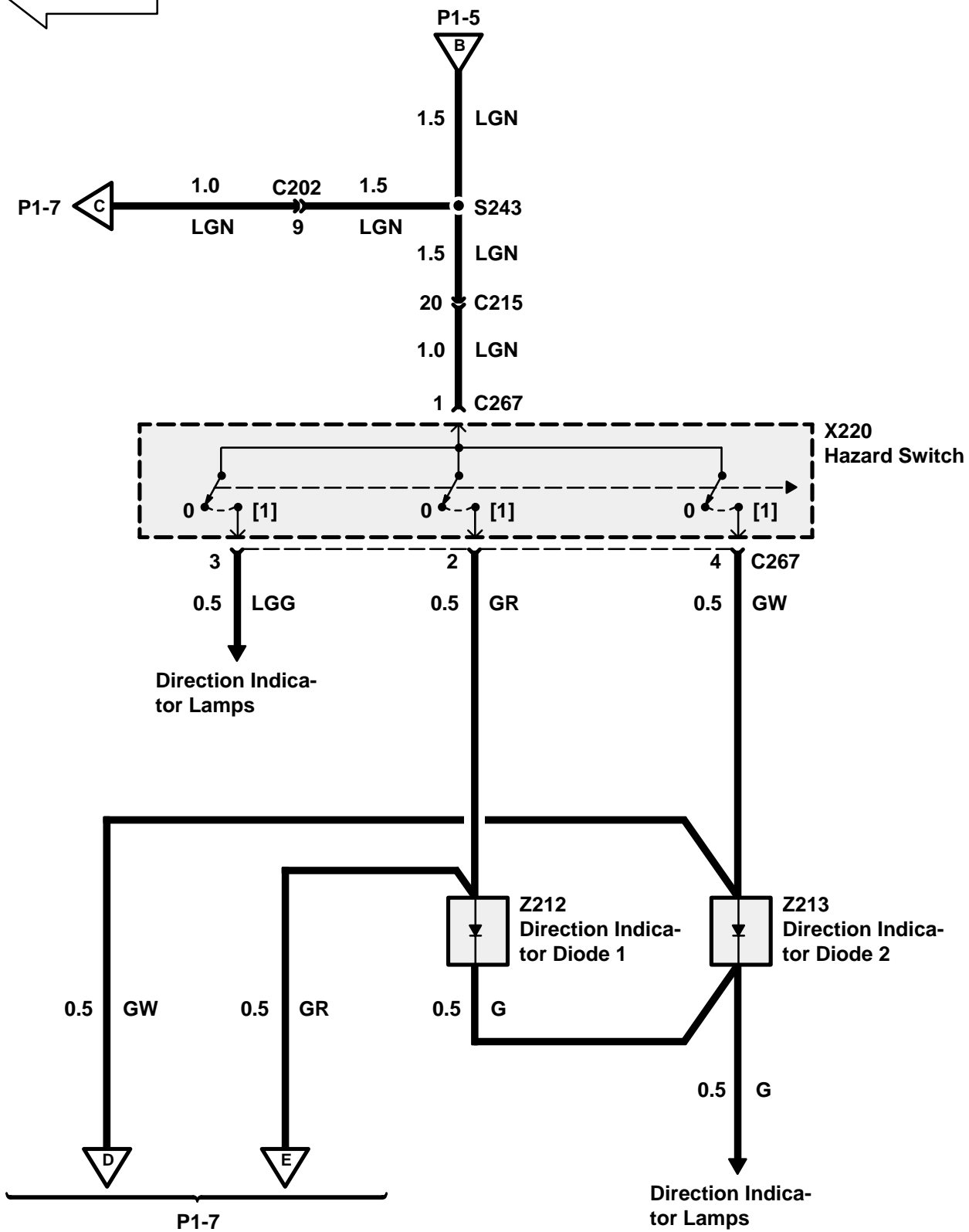
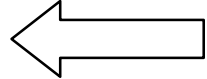



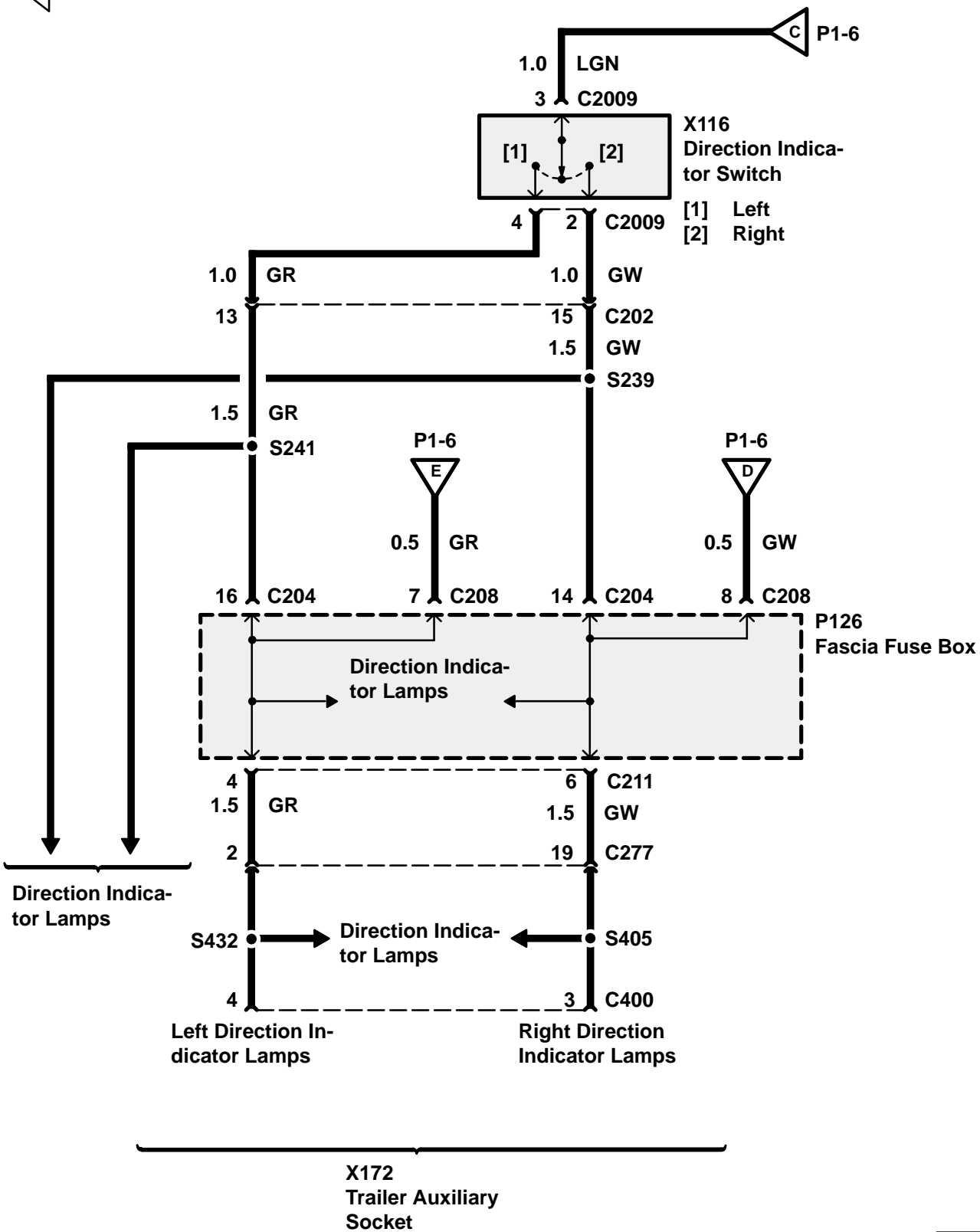
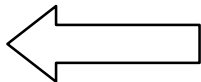

## CIRCUIT OPERATION

For 1995 models a vehicle alarm system is available as original equipment. The main function of the system is to offer easy-to-use remote locking and unlocking of the vehicle without having to actively select the alarm function.

## ALARM COMPONENTS

4. Theft Alarm Unit (Z163) and Theft Alarm Relay (K159)
5. Alarm Bonnet Switch (X212)
6. Tailgate Switch (X170)
7. Horns (K128, K134) and Horn Relay (K189)
8. Theft Alarm LED (B151)
9. Alarm Sensor (X213) (Not on all vehicles!)
10. Front Door Key Switches (X201, X202)
11. Lock Actuators (M114, M122, M117, M125, M132)
12. Handset Transmitter (two supplied)

## ANTI-THEFT SYSTEM FUNCTION

### Perimetric Protection

Using the key in the correct sequence will turn on and off perimetric protection only. When fully perimetrically armed, all doors, tailgate, and bonnet are protected against unauthorized access. If the door key is used in the normal manner the driver will be unaware of the door key sequence. The time taken to lock or unlock with the key must be less than 5 seconds. To prevent unauthorized tampering, the alarm will sound if the key is held in the unlocked position for longer than 5 seconds when armed. Cranking is disabled when perimetric protection is armed.

NOTE: When key is turned left or right, the keyswitch input will be activated, in conjunction with the sill button switch when links are operated.

### Volumetric Protection

Using the handset transmitter will turn On and Off volumetric protection. In volumetric mode the vehicle interior is protected using the Alarm Sensor (X213). Using the handset also arms and disarms the vehicle perimetrically. Cranking is disabled

when volumetric and perimetric protection is armed.

NOTE: If armed volumetrically, the vehicle CANNOT be disarmed using the key.

### Alarm Sounder (Z171)

When an intrusion is detected the Alarm Sounder (Z171) will sound intermittently (Switzerland and Denmark continuous horn sound) and the hazard lights flash (where territorial regulations allow) for 30 seconds. The alarm must be retriggered before the Alarm Sounder (Z171) will sound again.

### Vehicle Status Indication

Vehicle status is indicated by up to three devices: (a) Alarm Sounder (Z171), (b) hazard lights, (c) Theft Alarm LED (B151). When the vehicle arms in either mode, the hazard lights will flash three times and the LED will flash rapidly for 10 seconds. LED will then flash at a slower rate while vehicle is armed. When the vehicle disarms, hazard lights will flash once and LED will extinguish. If LED remains lit, it indicates that the alarm has been triggered. Turning on ignition or arming the alarm will extinguish LED. The LED will give a long pulse flash to indicate the Alarm Sensor (X213) being activated.

### Central Locking

Central Locking is controlled by the Theft Alarm Unit (Z163) and may be operated by the key, sill button(s) or handset. The system works on both front doors on four door vehicles or driver's door on two door vehicles.

NOTE: The central door locking system will shut down for a period after more than 15 consecutive operations.

### Inertia Switch

An inertia switch is incorporated in the Theft Alarm Unit (Z163). If ignition is on and the vehicle receives an impact sufficient to activate the inertia switch, the unit will signal to unlock central locking actuators and flash hazard lights. Central locking will remain disabled for 30 seconds. To reset, turn ignition off and then on after the 30 second period has elapsed.

### Alarm Sensor (X213)

The sensor operates by emitting an air pressure carrier wave and receiving the wave back. Any disturbance within the vehicle which disturbs the wave will be detected, triggering the alarm. When the volumetric sensor is activated it monitors movement within the vehicle for 15 seconds before detecting and responding to intrusions. If the sensor detects movement within the vehicle it delays arming until a 15 seconds quiet period has elapsed. If continuous movement is detected, the alarm will not arm volumetrically.

### Radio Frequency System

The RF system uses four frequencies according to market. If the coaxial aerial is not fitted system performance will be impaired. Both ECU and handset have a colour-coded label.

Frequency Colour Territory ECU/Handset:

418.0 MHz, Pink/pink: UK, Ireland

224.5 MHz, Yellow/yellow: France

433.92 MHz, Blue/blue: Europe (not France, Switzerland, Italy, Denmark)

433.92 MHz, White/blue: Switzerland, Denmark

315.0 MHz, Green/green: Rest of World, Italy, Australia

315.0 MHz, Orange/green: Gulf, Japan

### Partially armed mode

If a door, tailgate or bonnet is left open when the system is armed, the LED will not light for 10 seconds indicating a mislock condition. Hazard lights will not flash. If an open door or tailgate is causing the mislock, the starter motor is disabled. The alarm will sound if ignition is turned to start position. If an open bonnet is causing the mislock the starter motor is disabled. The alarm will arm the volumetric part of the system. If the door tailgate or bonnet is subsequently closed, after a 5 second delay, the doors will unlock and immediately lock, and the system will fully arm.

### Handset Transmitter

The handset LED will give one flash when button is pressed momentarily. If button is held down the LED will light again after 2 seconds for 2 seconds, and extinguish until button is released and repressed. The handset contains unique information distinguishing it from other transmitters. It also contains a set of 'random' rolling codes programmed into the ECU before leaving the factory. Each time the handset is pressed a different code is transmitted to the ECU.

If the handset is operated more than four times outside the vehicle range (6 metres) or power supply is removed, it will be necessary to re-synchronise handset and the ECU by pressing the handset three times within range and within 5 seconds.

NOTE: If both handsets are lost or damaged when system is armed, it will be necessary to fit a new ECU with two matching handsets.

### Handset Batteries

If handset LED flashes continuously when button is pressed, the batteries need replacing. The hazard lights will flash one 3 second pulse, instead of three times upon arming vehicle.

### Power Up Mode

The alarm system always remembers the state it was left in when power was removed. If the alarm powers up in an armed state and is subsequently triggered, it will give a warning that it will fully trigger unless disarmed. This warning consists of

short horn pulses every two seconds for 15 seconds.

### New Born Mode

When the ECU is first produced, it will be in its 'new born' mode. In this mode it will respond to any remote of the right frequency. This mode will be cancelled when the ECU has received ten valid handset signals without power interruption.

### Engine Cranking

It is only possible to crank the engine when ignition is ON and alarm disabled.

**BUILT IN TEST PROCEDURE**

The built in test procedure is accessed as follows:

1. Starting conditions: ignition off, doors unlocked, bonnet switch depressed.
2. Carry out instructions 3 to 7 within 8 seconds.
3. Release bonnet switch.
4. Switch ignition ON.
5. Lock doors.
6. Switch ignition OFF.
7. Switch ignition ON.

If alarm is correctly accessed, horn will sound and LED will flash. The following checks can be made:

8. Open and close any door or tailgate – LED will light.
9. Depress bonnett switch – hazards will flash.
10. Check engine cranking is disabled. Do not turn off ignition.
11. Check ultrasonic by operating handset, LED will emit one 5 second flash, and will flash if interior is disturbed.

NOTE: If ECU is in new born mode, any handset of the right frequency will work. If not, initialised handset is required. See Handset Initialisation.

12. Turn OFF ignition or press handset to end test procedure. Horn will sound as before to indicate end of test mode.

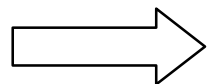
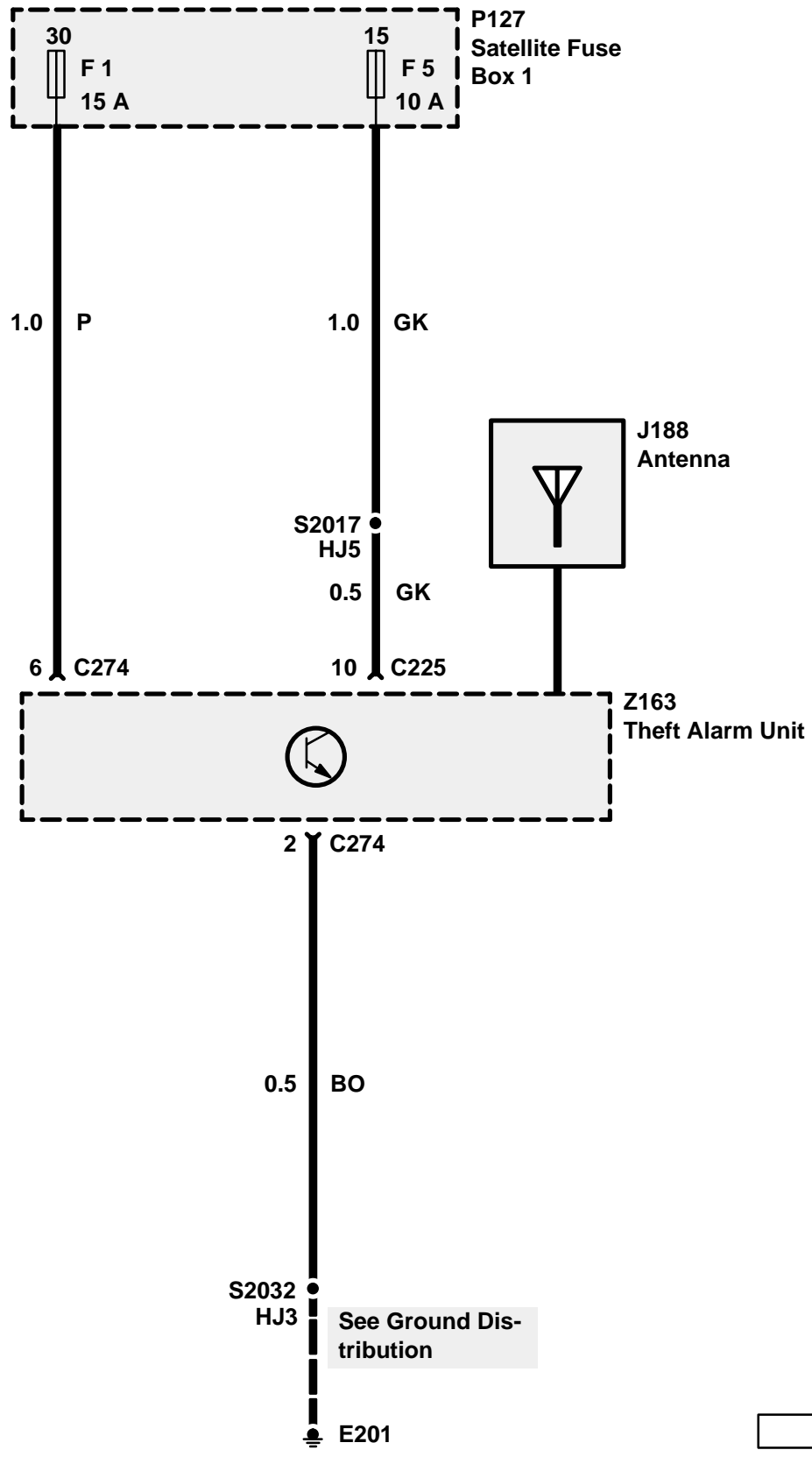

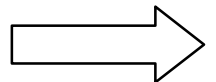
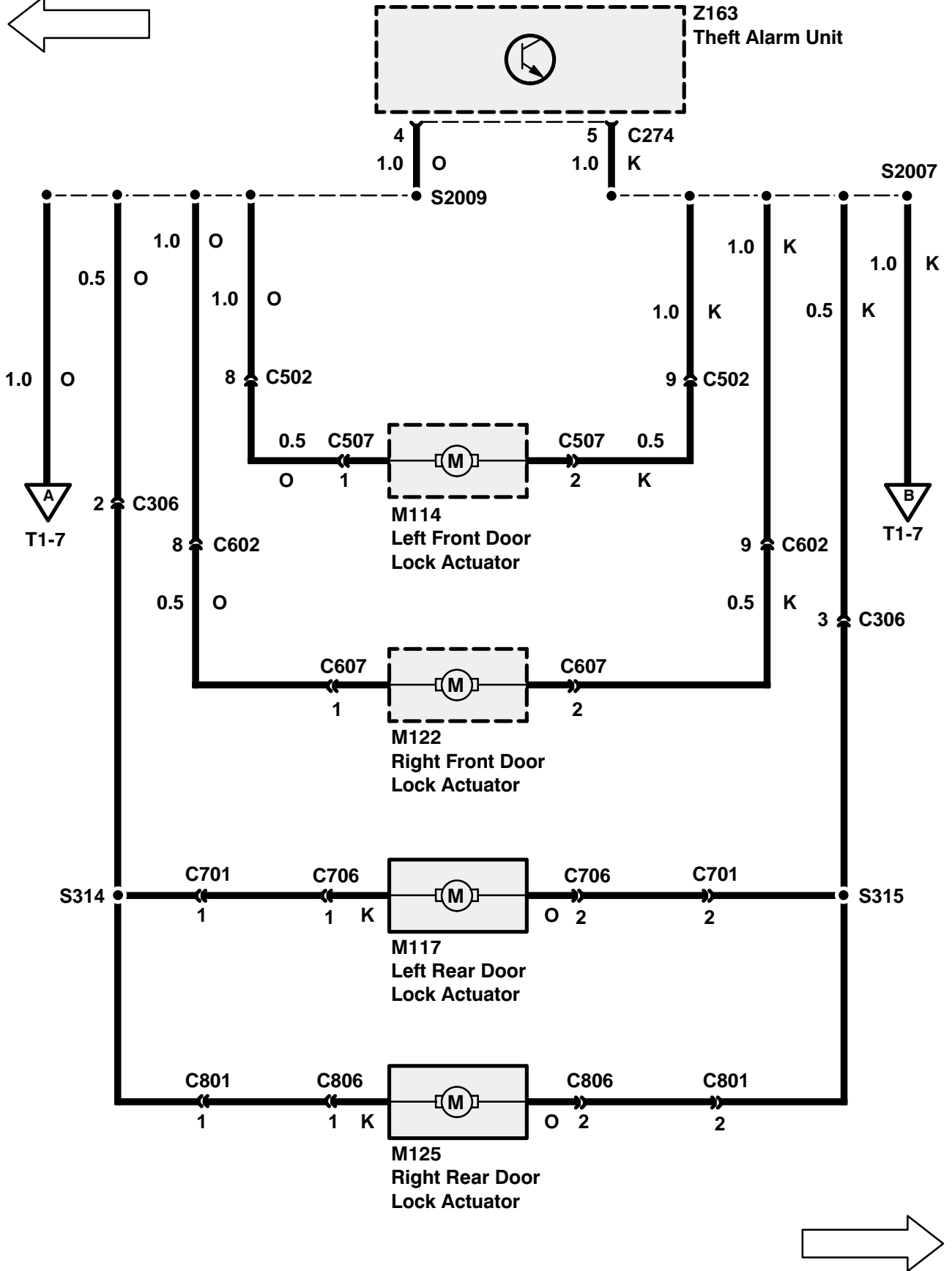

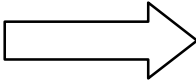
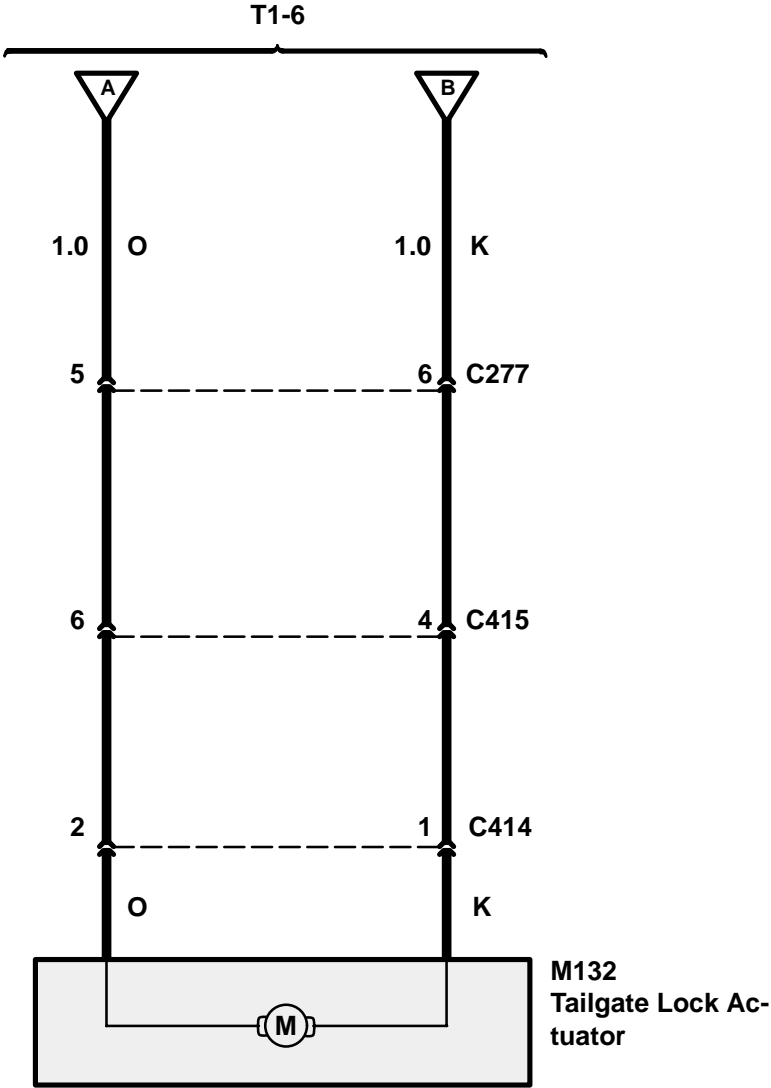
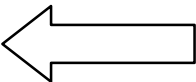



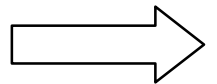
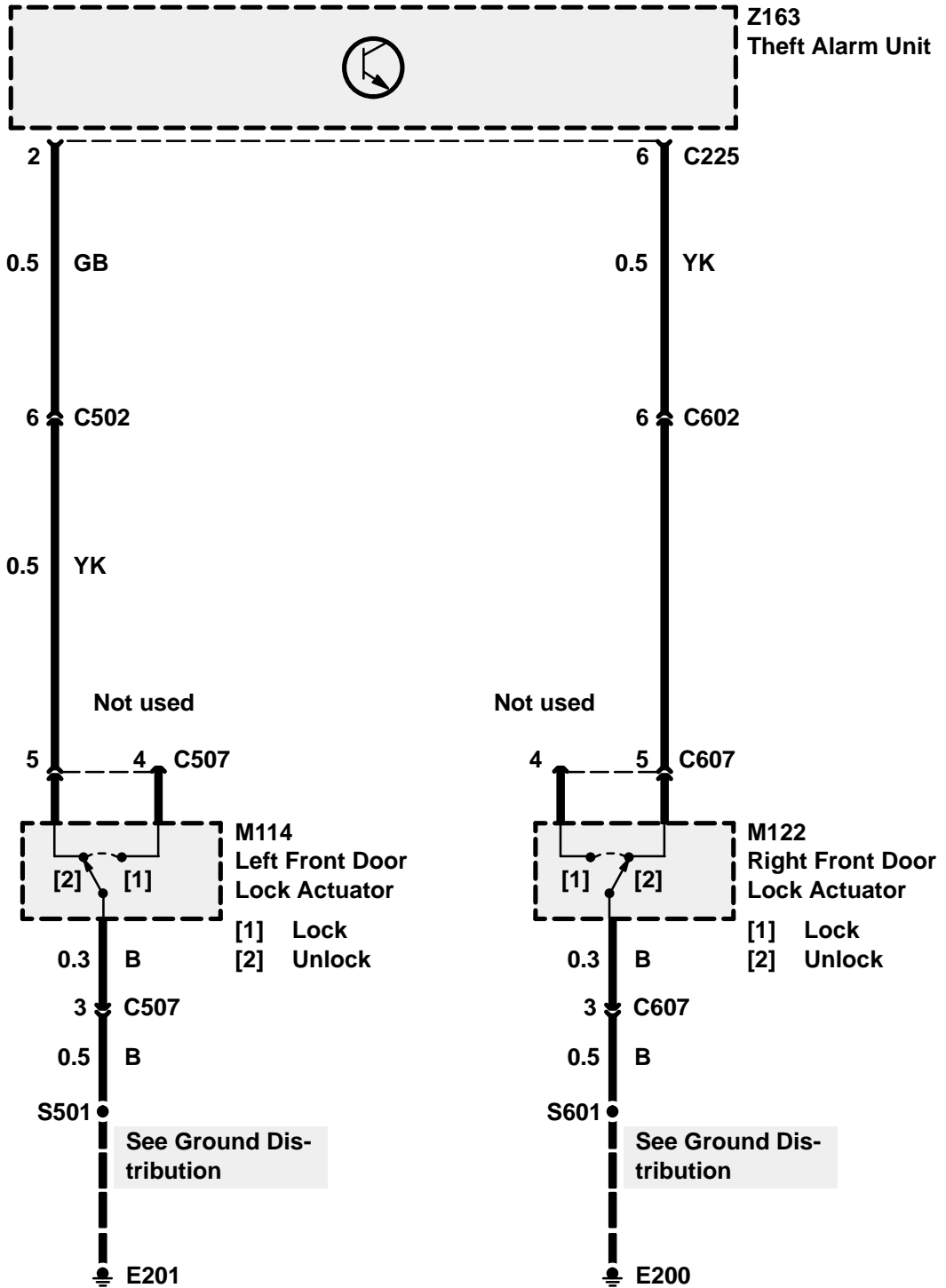
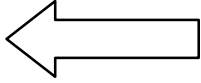

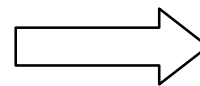
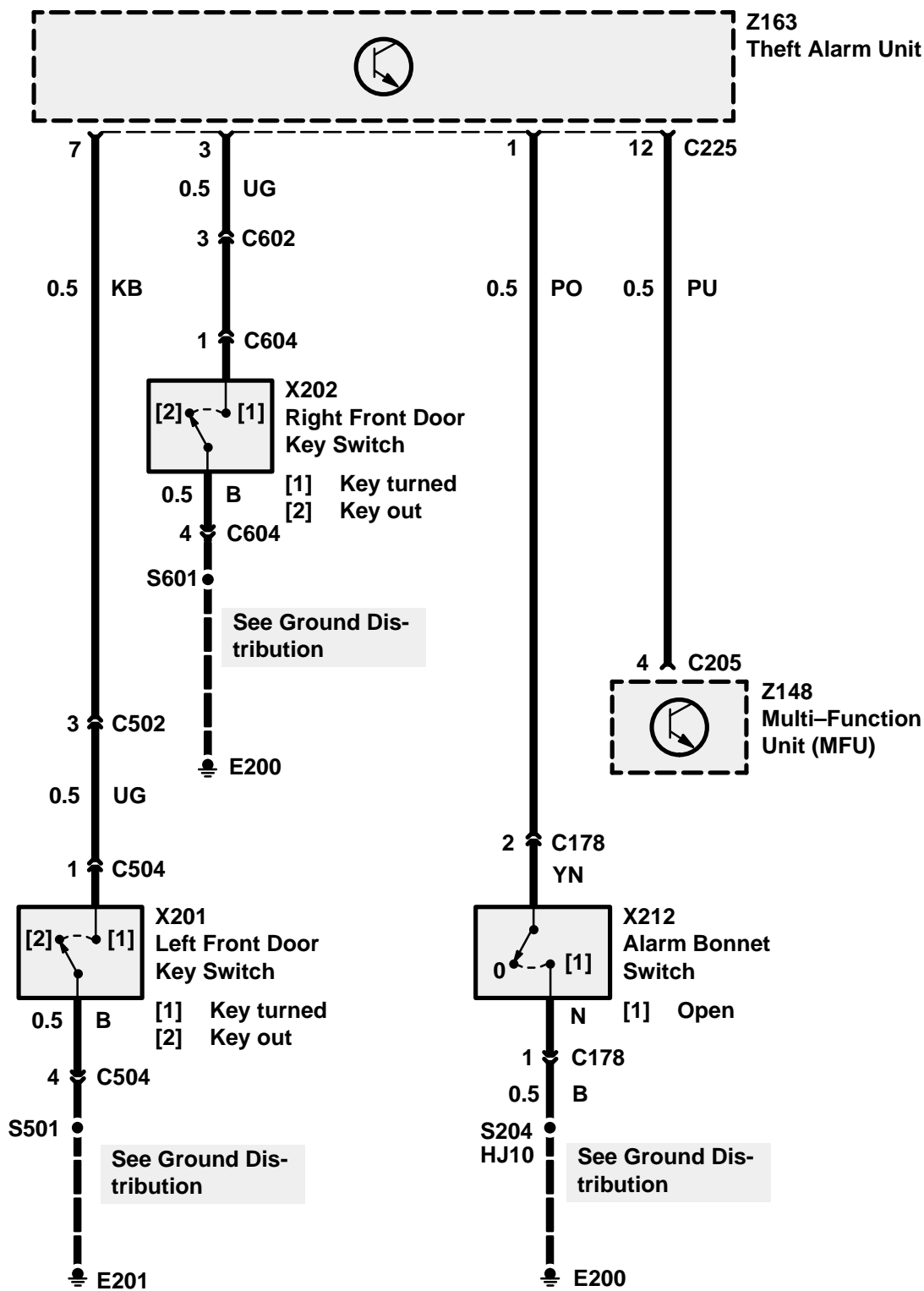
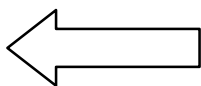

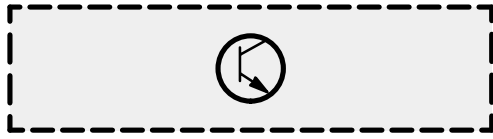
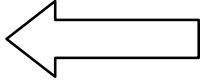

Z163 Theft Alarm Unit

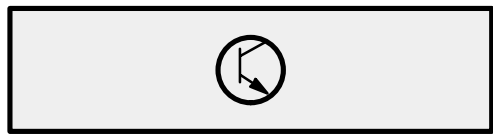
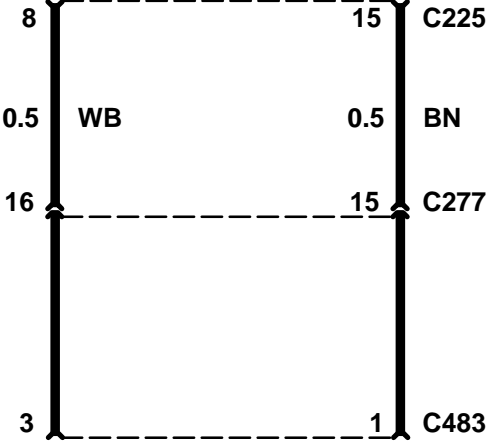

X213 Alarm Sensor

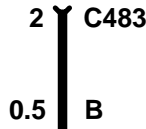

See Ground Distribution

E401

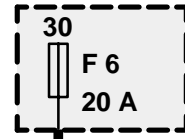

P128 Satellite Fuse Box 2

See Fuse Details

S2061

0.5 P

1 C269

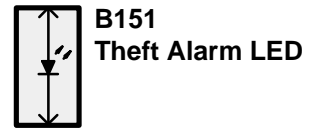

2 C269

0.5 RW

4 C209

14 C225

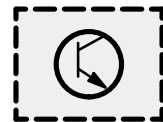

Z163 Theft Alarm Unit

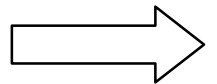

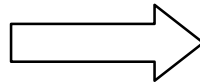
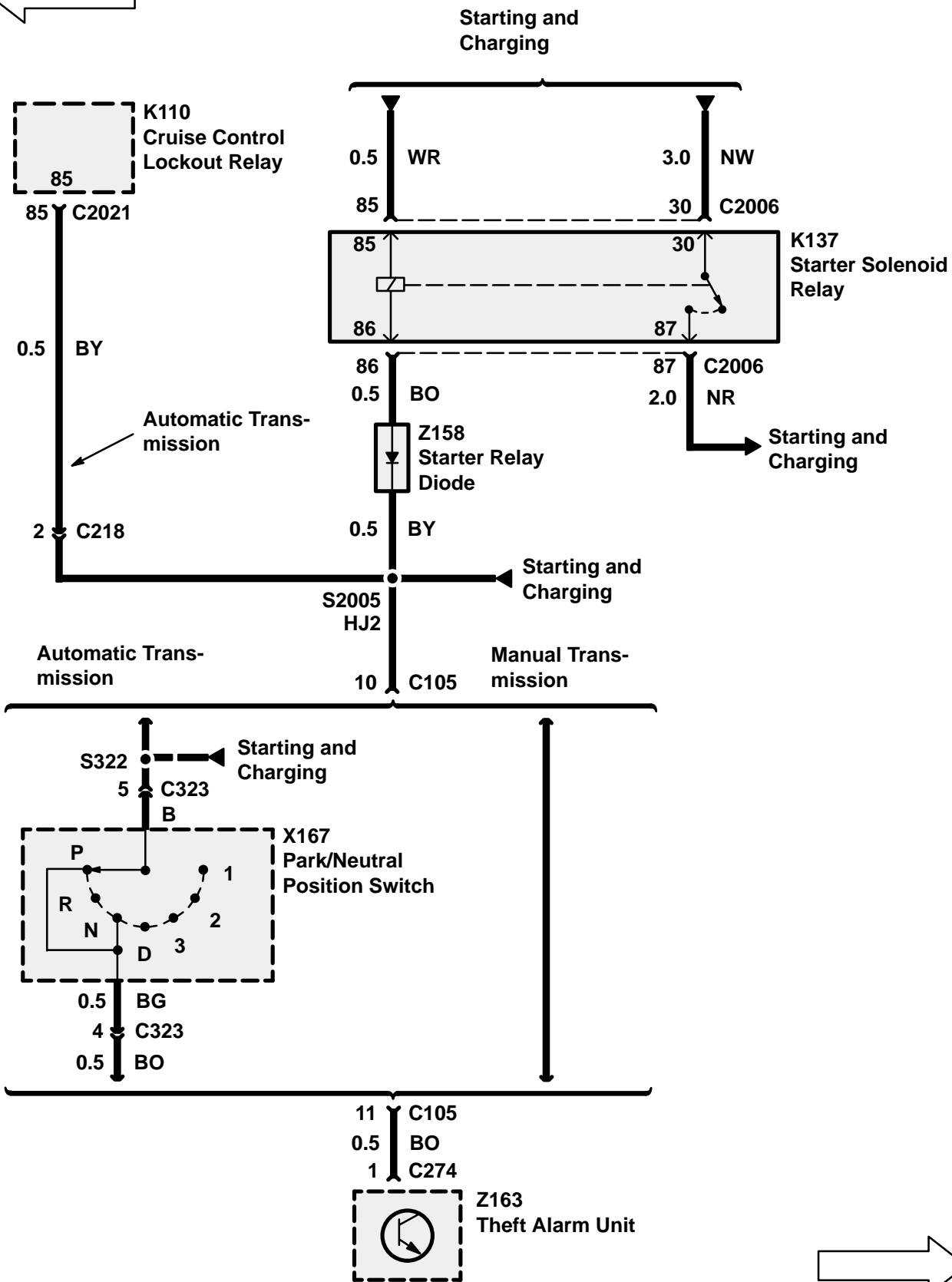
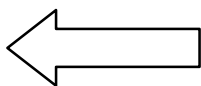

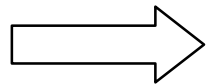
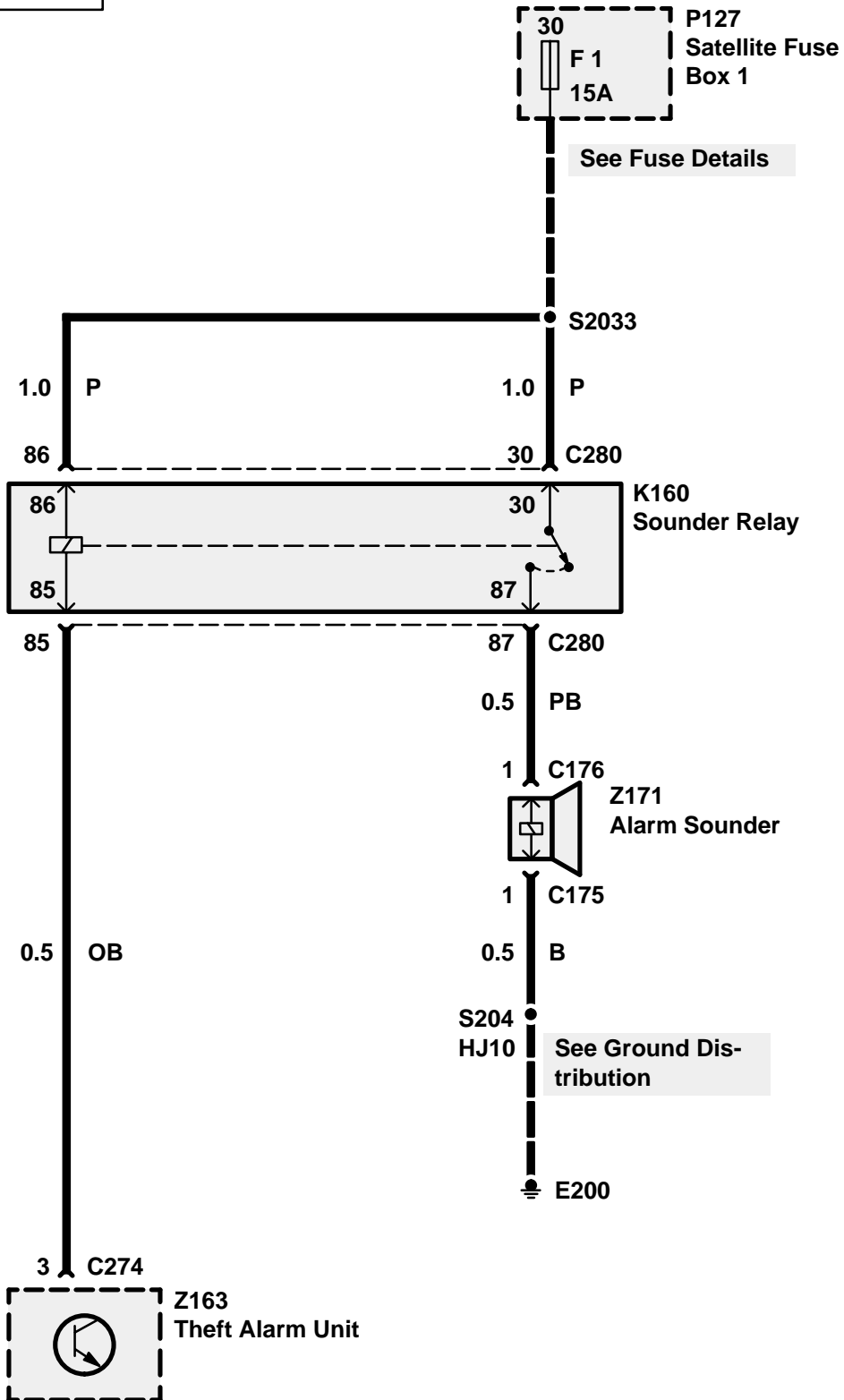
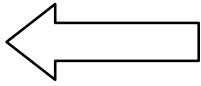

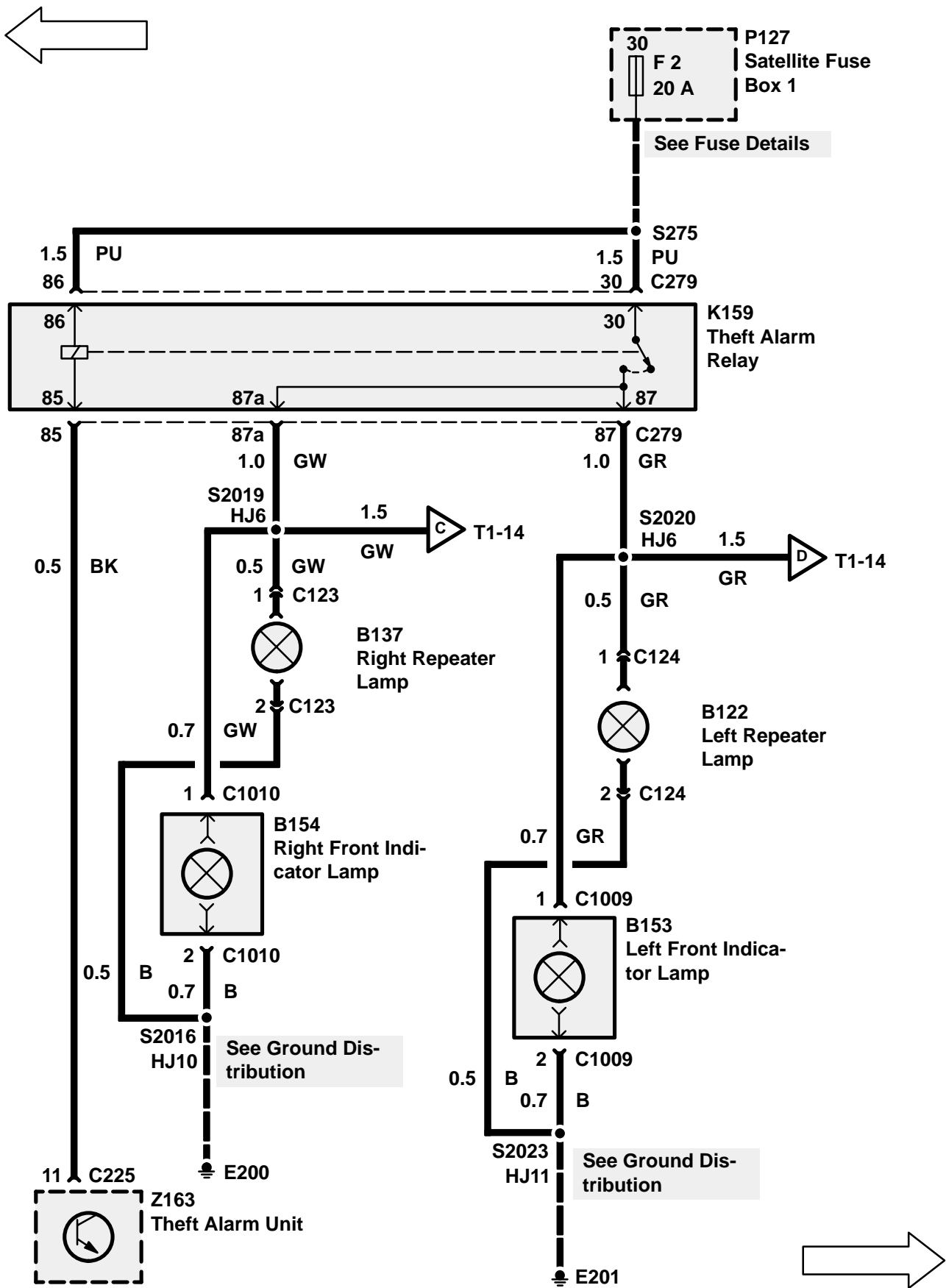

# T1 ETM

## DISCOVERY

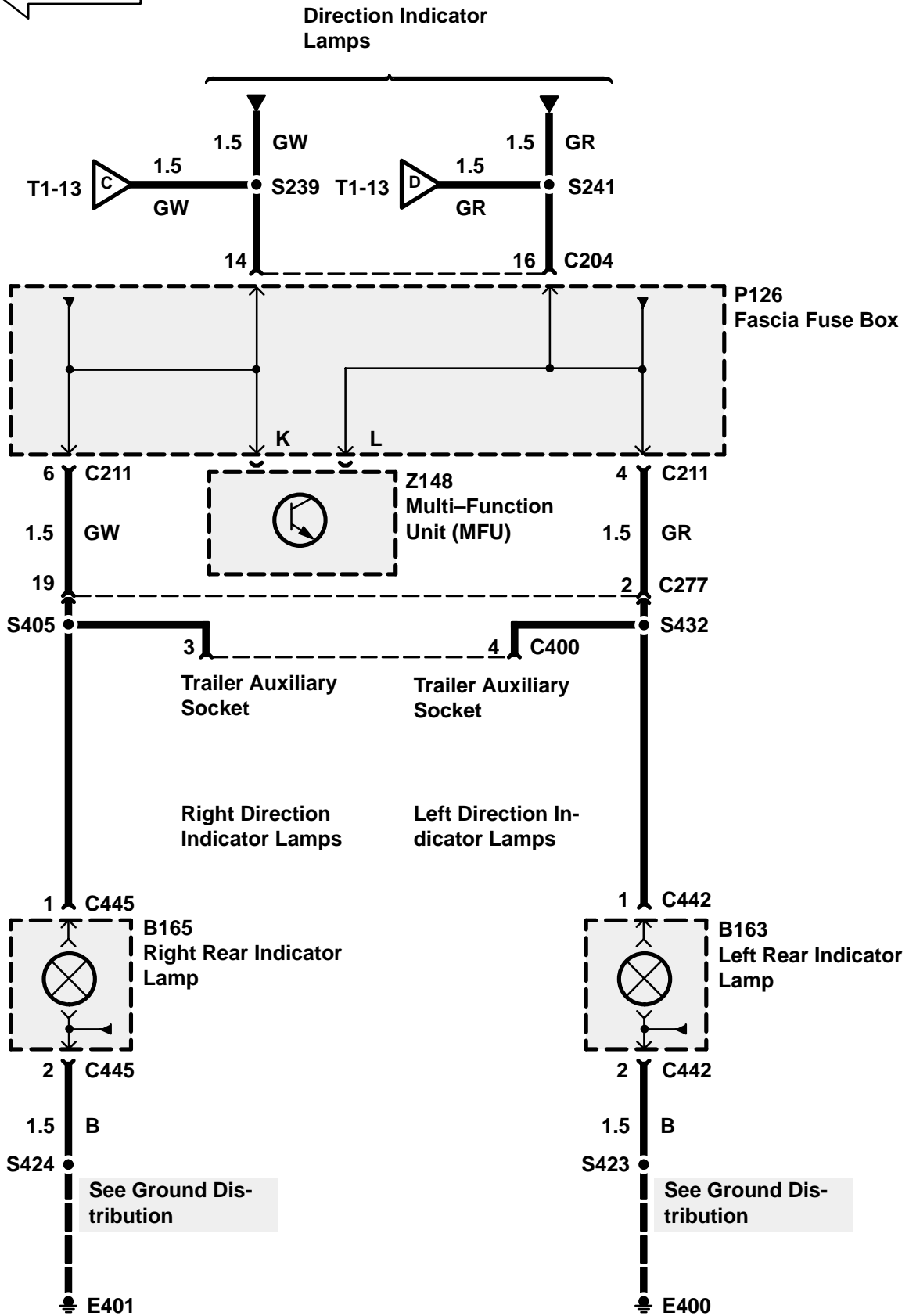
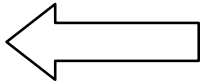

**TROUBLESHOOTING HINTS**

13. Check Fuses F1, F2 and F5 in Satellite Fuse Box 1.
14. Check Fuse F5 in Satellite Fuse Box 2.
15. If the interior lights do not come on when a door is open, check suspect door switch and associated wiring.
16. If all of the lock actuators do not operate, check O and K Wire. If OK, replace Theft Alarm Unit (Z163).

**SYSTEM DIAGNOSIS**

1. If the system will not arm, do Test A.
2. If the system arms, but will not trigger at all, do Test C.
3. If the Alarm Sounder (Z171) does not sound when triggered, do Test C.
4. If the hazard lights do not flash when triggered, do Test F.
5. If the system will not trigger when the bonnet is open, do Test G.
6. If the alarm is set using the remote and the system does not trigger the alarm when there is motion inside the vehicle, do Test H.
7. If the Theft Alarm LED (B151) does not operate, do Test D.
8. If the Alarm Sounder (Z171) sounds continuously, do Test E.
9. If the system will not disarm, do Test A.
10. If a Front Door Lock Actuator (M114, M122) does not operate, do Test J.
11. If the doors unlock themselves after operating the door locks, do Test K.
12. If the central locking function does not operate from one of the front doors, do Test L.
13. If the Tailgate Lock Actuator (M132) does not operate, do Test M.
14. If both Rear Door Lock Actuators (M117, M125) do not operate, do Test N.



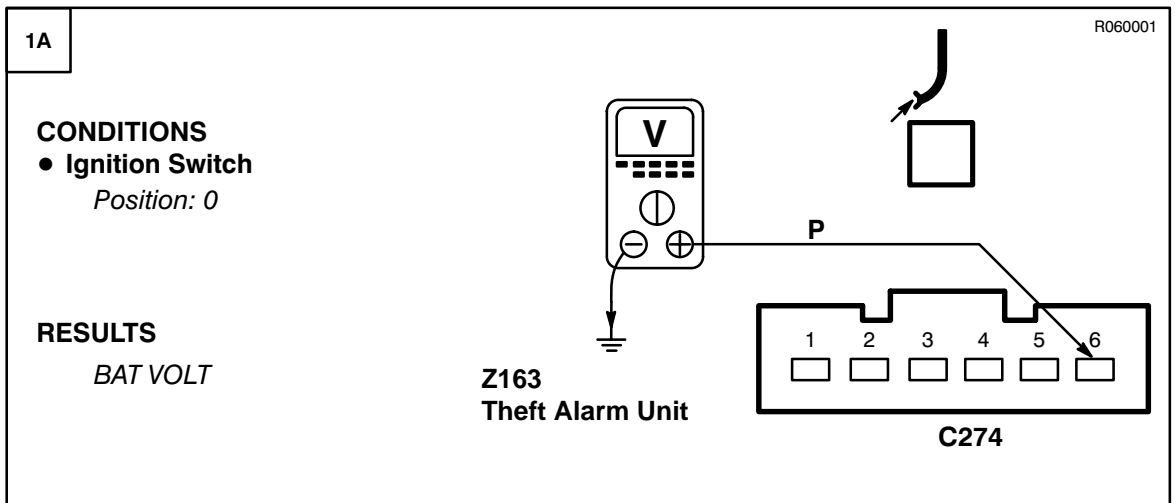

~~OK~~ PROBLEM CAUSE  
 - P Wire

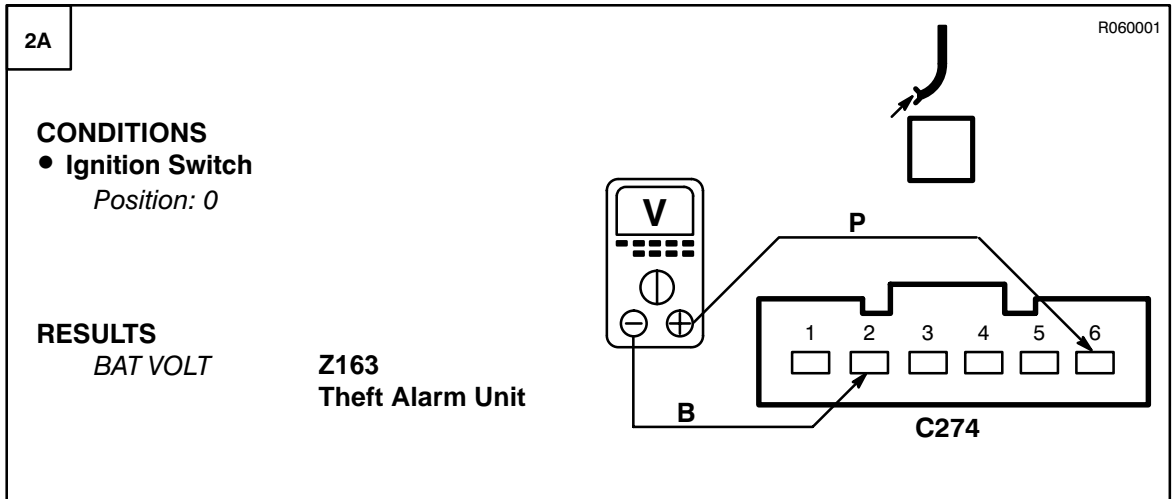
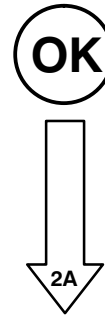

~~OK~~ PROBLEM CAUSE  
 - B Wire

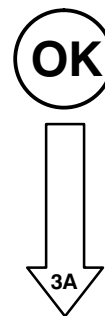

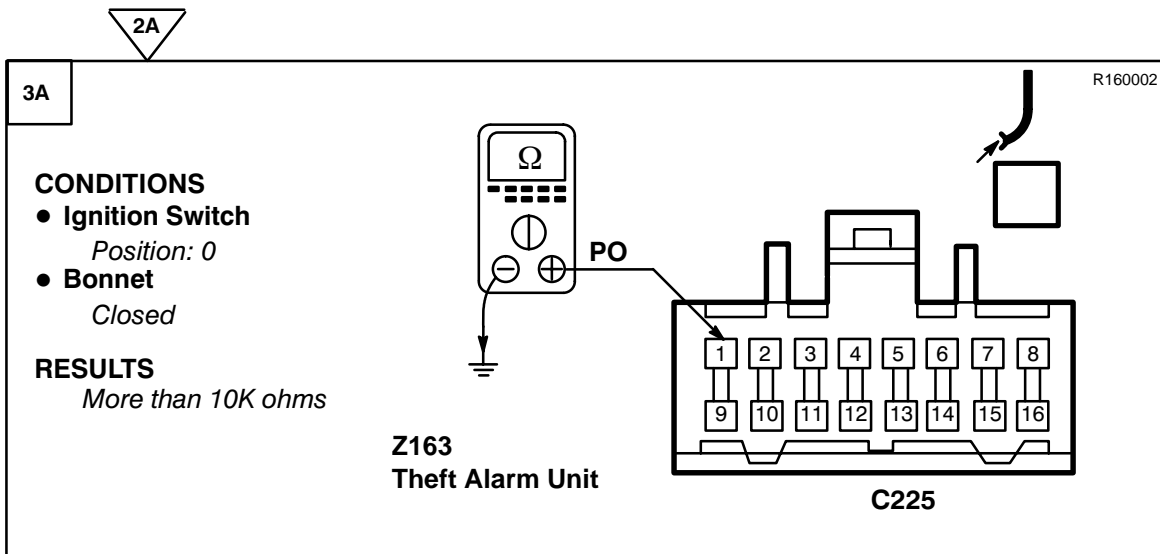

~~OK~~ **PROBLEM CAUSE**  
 - PO Wire  
 - Alarm Bonnet Switch

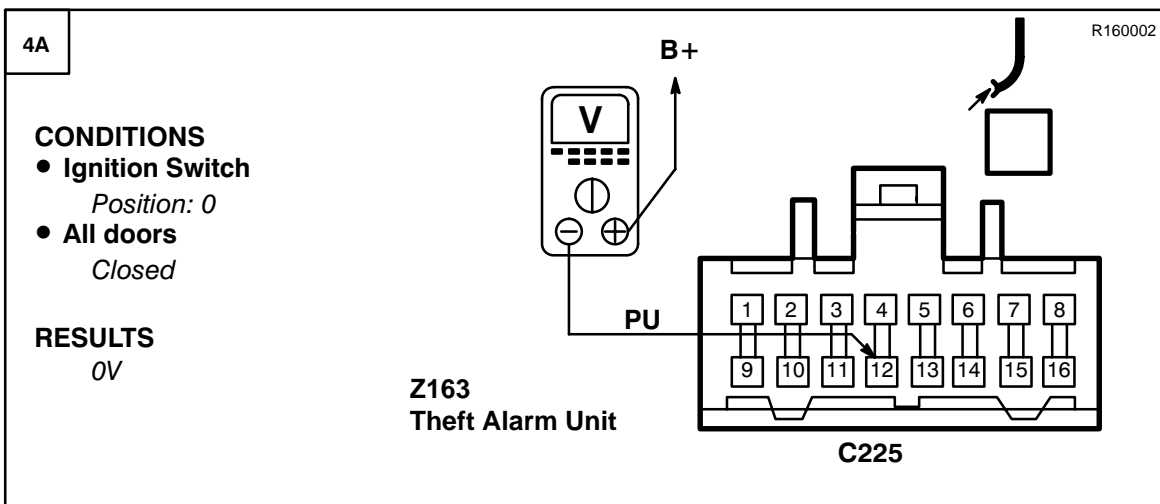
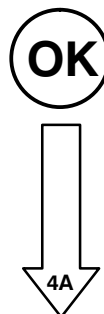

~~OK~~ **GO TO TEST B**

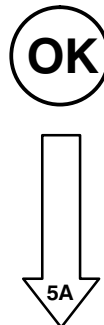

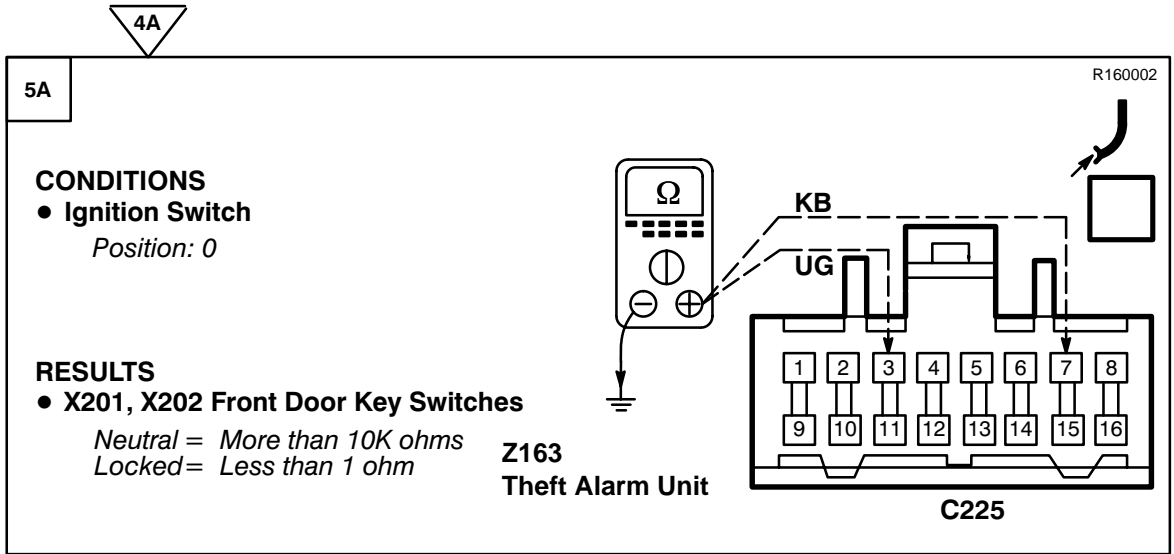

**PROBLEM CAUSE**

- UG Wire
- KB Wire
- B Wire
- X201, X202 Front Door Key Switches

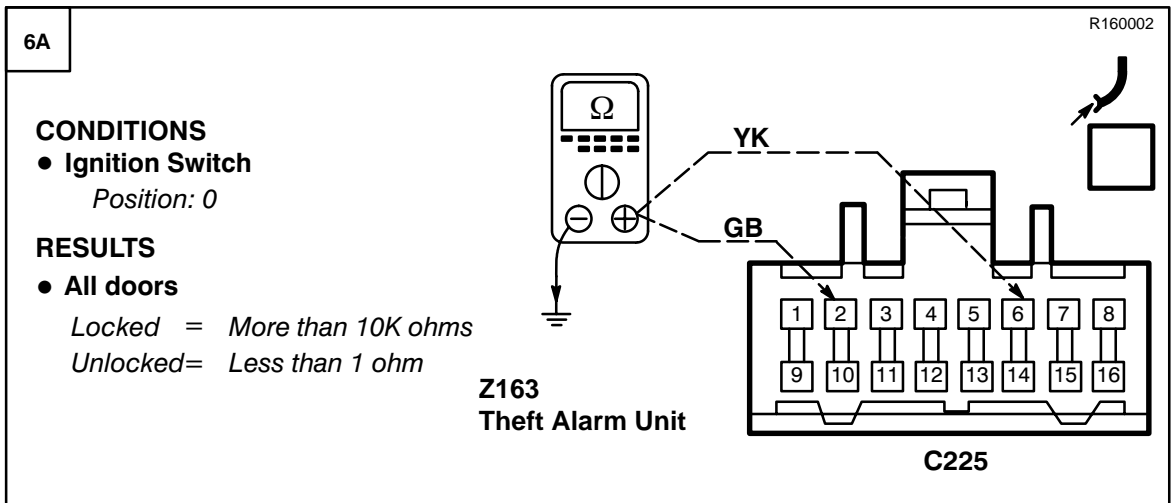
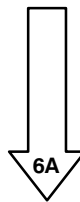

**PROBLEM CAUSE**

- GB Wire
- YK Wire
- B Wire

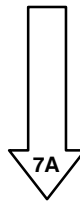

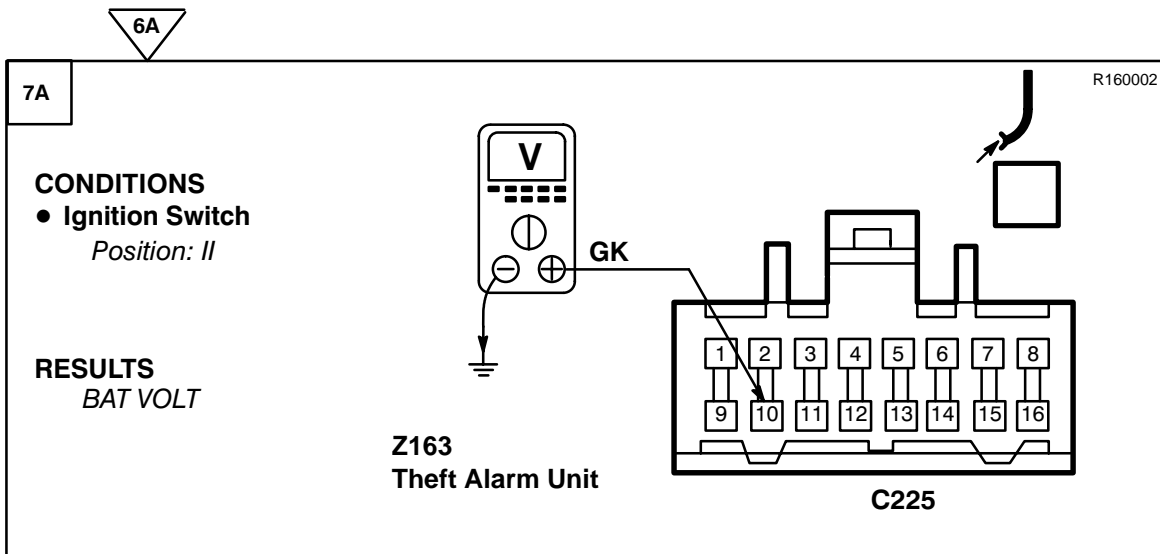

**PROBLEM CAUSE**  
- GK Wire



**PROBLEM CAUSE**  
- Theft Alarm Unit

**Test B**

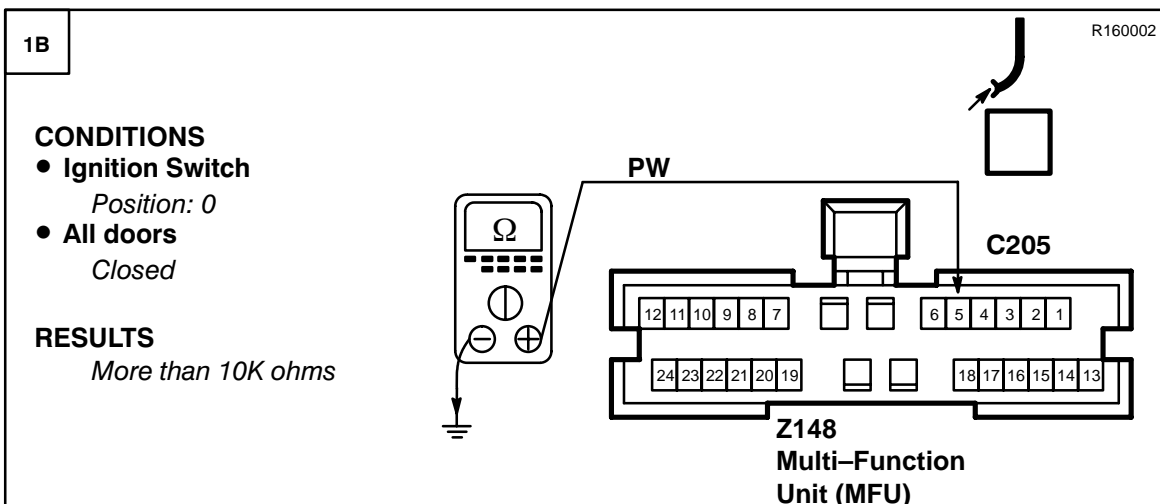

**PROBLEM CAUSE**

- PW Wire
- Left Front Door Switch
- Left Rear Door Switch
- Right Rear Door Switch
- Rear End Door Switch

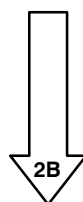

# T1 ETM

## DISCOVERY

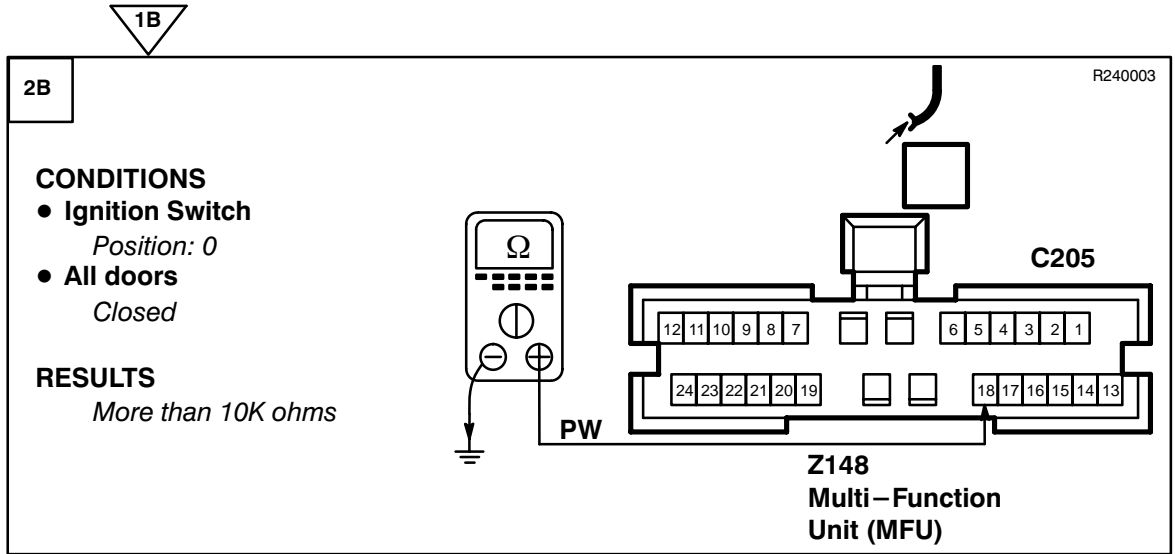

**PROBLEM CAUSE**

- PW Wire
- Right Front Door Switch



**PROBLEM CAUSE**

- PU Wire
- Multi-Function Unit (MFU)

### Test C

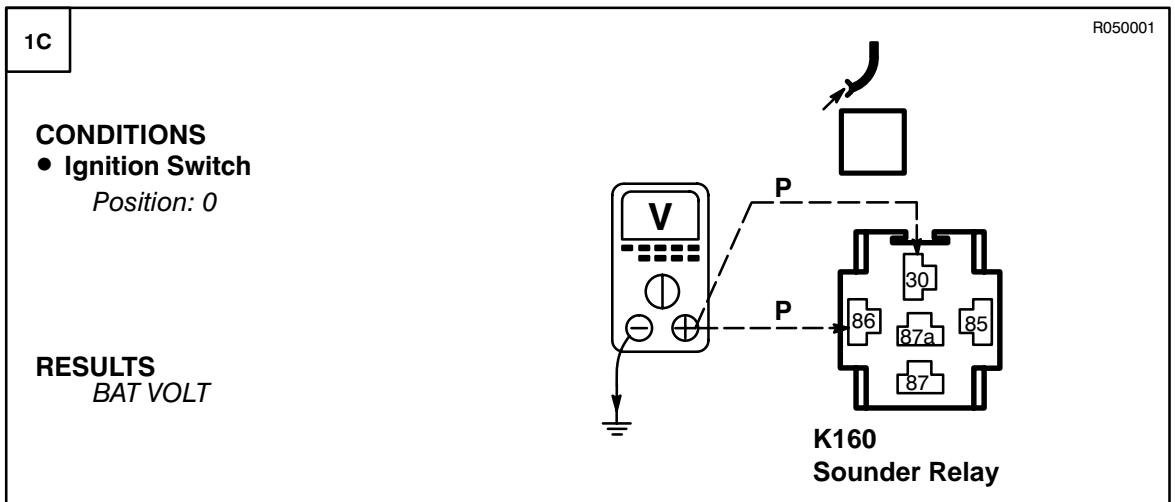

**PROBLEM CAUSE**

- P Wire

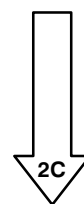

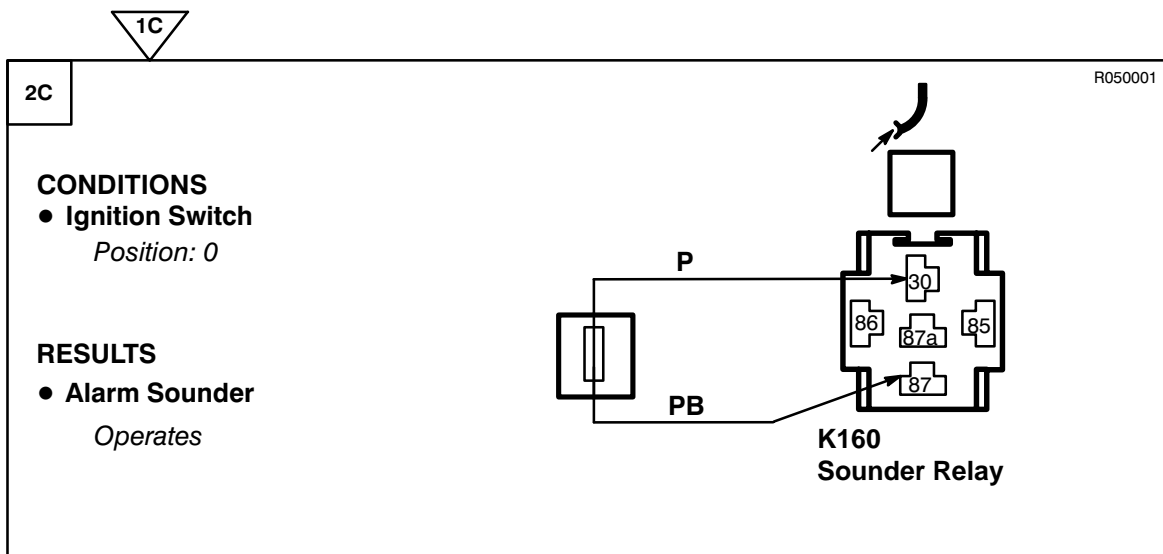

~~OK~~ **PROBLEM CAUSE**  
- PB Wire  
- Alarm Sounder

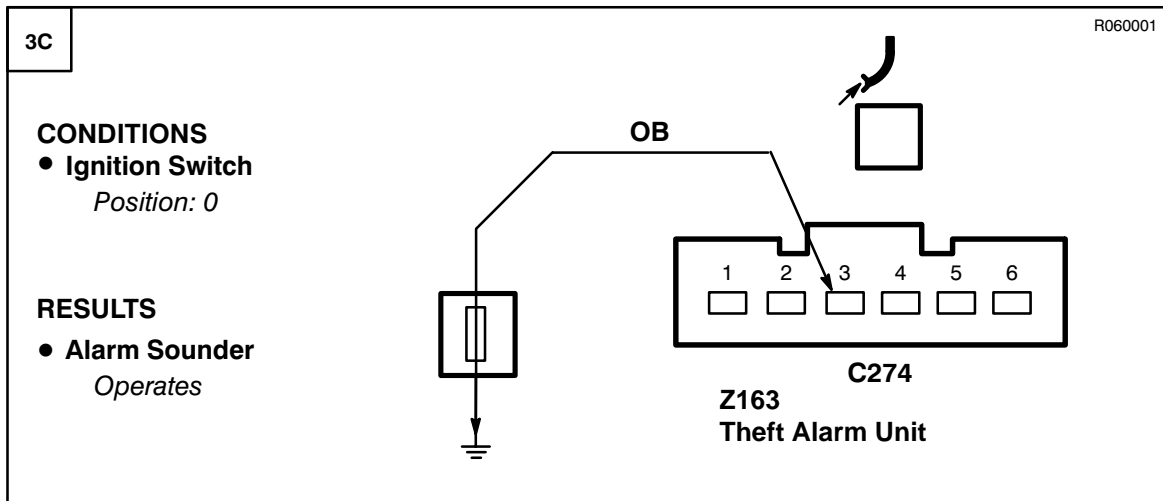
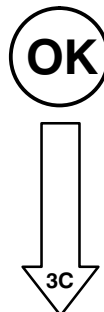

~~OK~~ **PROBLEM CAUSE**  
- OB Wire  
- Sounder Relay

~~OK~~ **PROBLEM CAUSE**  
- Theft Alarm Unit

# T1 ETM

## DISCOVERY

### Test D

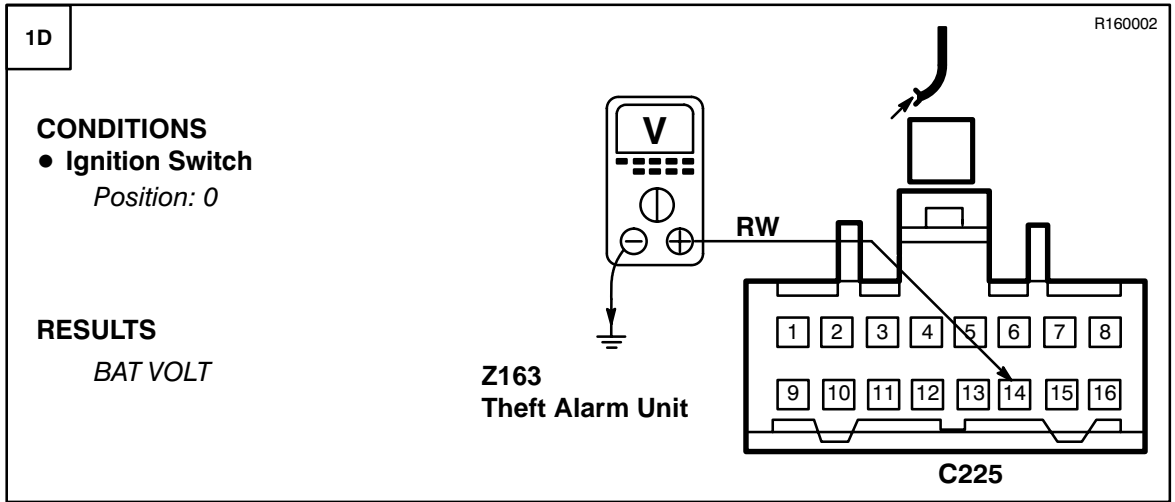

**PROBLEM CAUSE**

- RW Wire
- P Wire
- Theft Alarm LED



**PROBLEM CAUSE**

- Theft Alarm Unit

### Test E

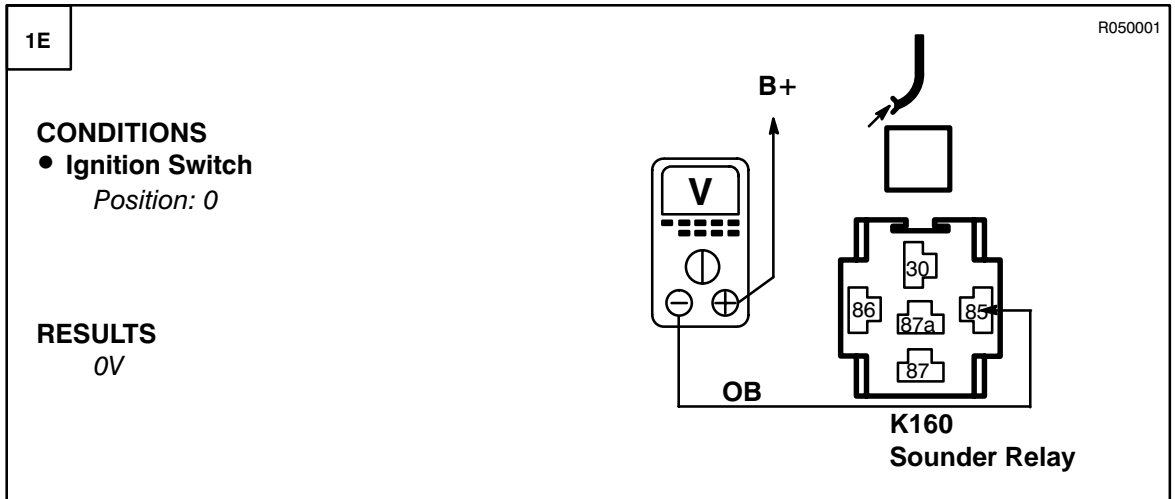

**PROBLEM CAUSE**

- OB Wire
- Theft Alarm Unit



**PROBLEM CAUSE**

- Sounder Relay

**Test F**

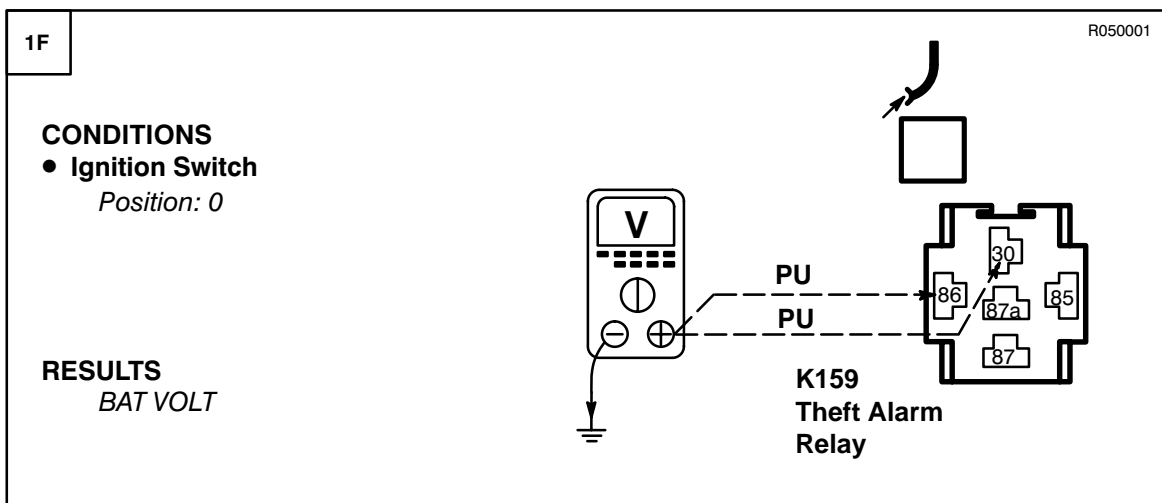

**PROBLEM CAUSE**  
- PU Wire

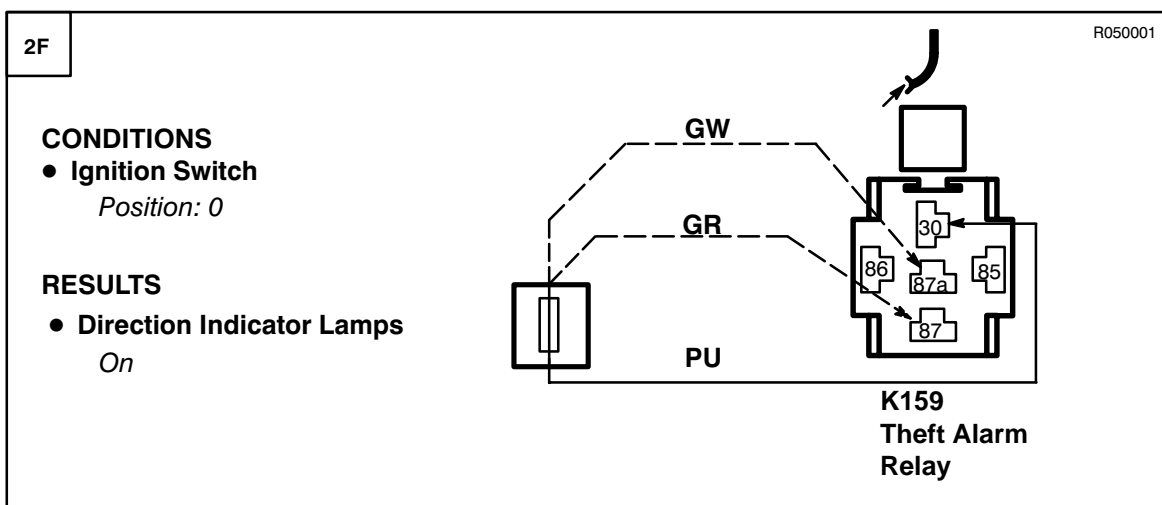
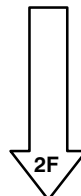

**PROBLEM CAUSE**  
- GR Wire  
- GW Wire

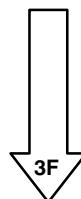



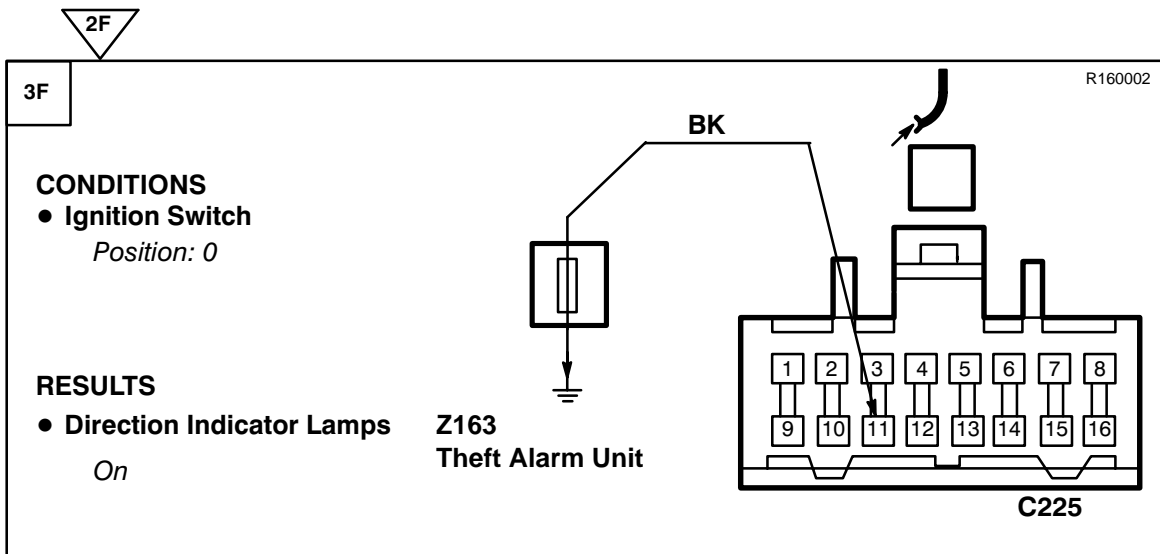

**PROBLEM CAUSE**

- BK Wire
- Theft Alarm Relay



**PROBLEM CAUSE**

- Theft Alarm Unit

### Test G

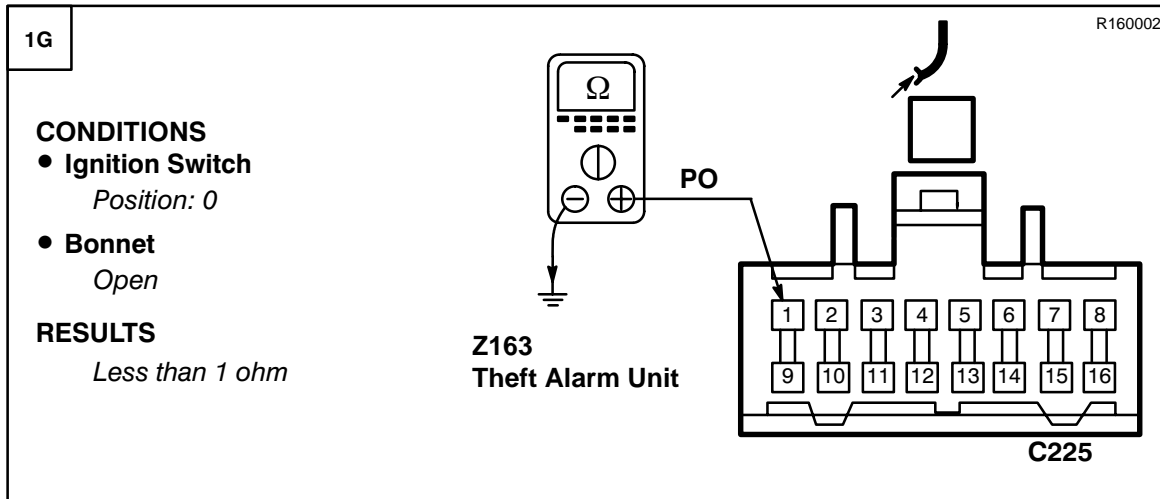

**PROBLEM CAUSE**

- PO Wire
- B Wire
- Alarm Bonnet Switch



**PROBLEM CAUSE**

- Theft Alarm Unit

**Test H**

**1H** R040006

**CONDITIONS**  
 • Ignition Switch  
*Position: 0*

**RESULTS**  
*BAT VOLT*

**X213**  
Alarm Sensor

**OK** **PROBLEM CAUSE**  
 - WB Wire  
 - Theft Alarm Unit

**OK**

↓  
2H

**2H** R040006

**CONDITIONS**  
 • Ignition Switch  
*Position: 0*

**RESULTS**  
*Less than 1 ohm*

**X213**  
Alarm Sensor

**OK** **PROBLEM CAUSE**  
 - B Wire

**OK** **PROBLEM CAUSE**  
 - BN Wire  
 - Alarm Sensor  
 - Theft Alarm Unit

Test J

R060009

1J

**CONDITIONS**

- Ignition Switch  
*Position: II*
- All doors  
*Locked*
- Unlock a front door

**RESULTS**  
*BAT VOLT (Momentary)*

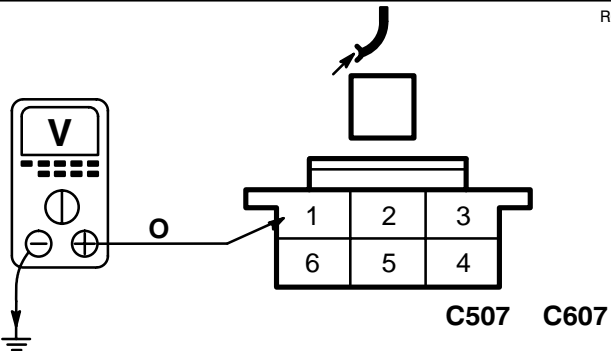

**M114, M122 Front Door Lock Actuator**

**OK** PROBLEM CAUSE  
- O Wire

**OK**

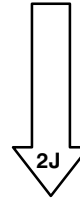

R060009

2J

**CONDITIONS**

- Ignition Switch  
*Position: II*
- All doors  
*Unlocked*
- Lock a front door

**RESULTS**  
*BAT VOLT (Momentary)*

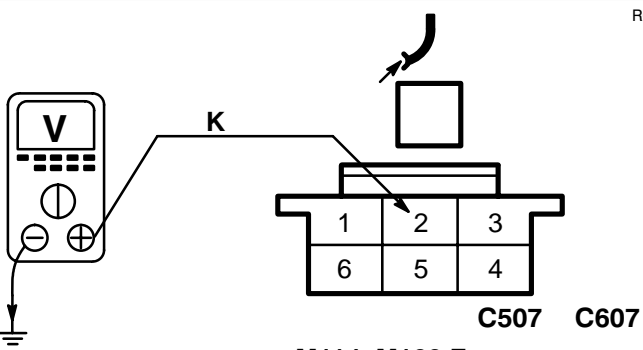

**M114, M122 Front Door Lock Actuator**

**OK** PROBLEM CAUSE  
- K Wire

**OK** PROBLEM CAUSE  
- M114, M122 Front Door Lock Actuator

**Test K**

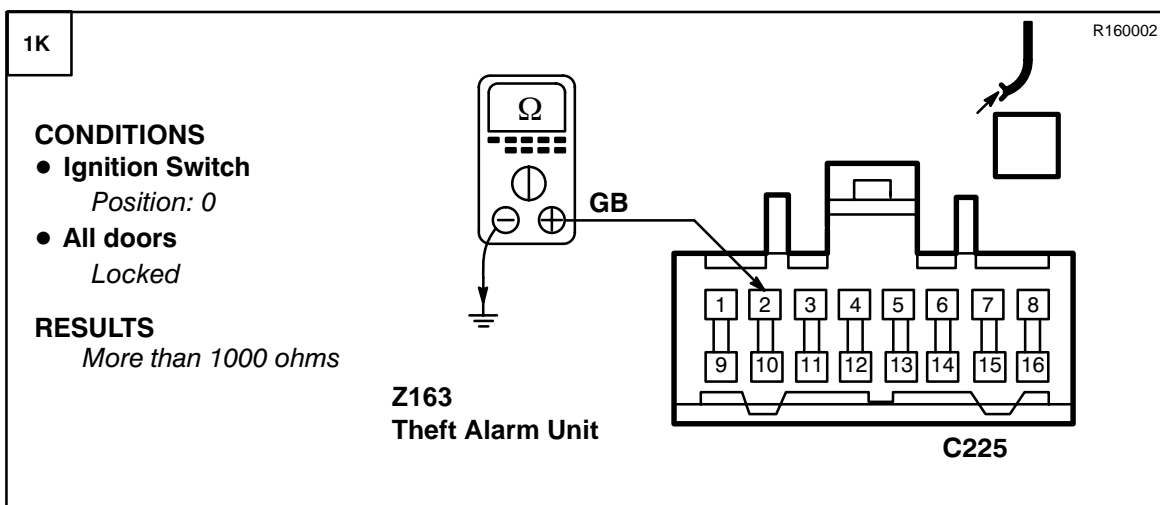

**PROBLEM CAUSE**

- GB Wire
- YK Wire
- Left Front Door Lock Actuator

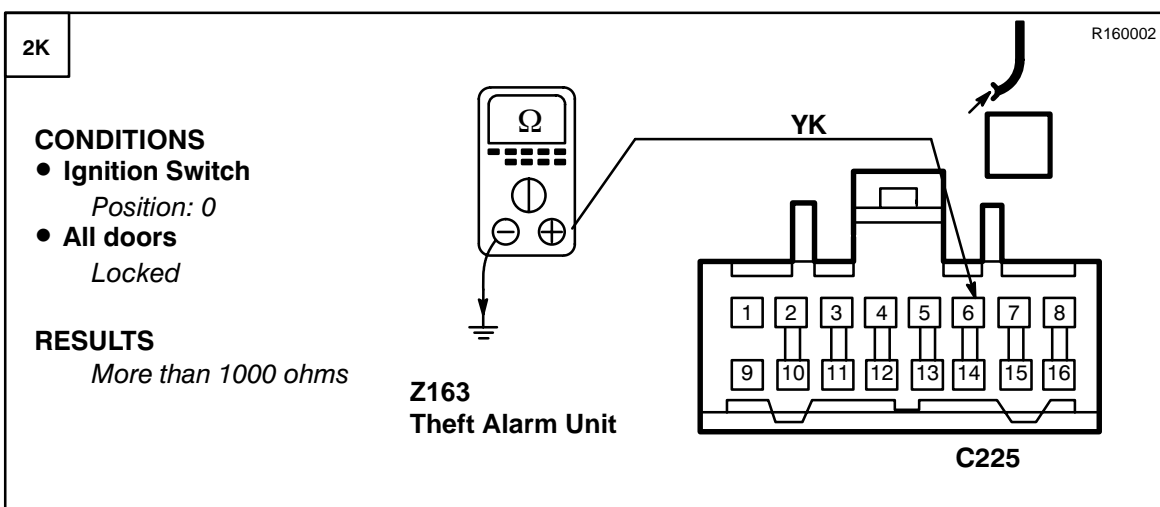
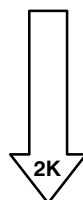

**PROBLEM CAUSE**

- YK Wire
- Right Front Door Lock Actuator



**PROBLEM CAUSE**

- Theft Alarm Unit

# T1 ETM

## DISCOVERY

### Test L

1L

R160002

**CONDITIONS**

- Ignition Switch  
*Position: 0*
- All doors  
*Unlocked*

**RESULTS**  
*Less than 1 ohm*

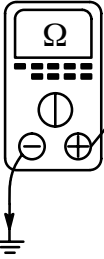

Z163  
Theft Alarm Unit

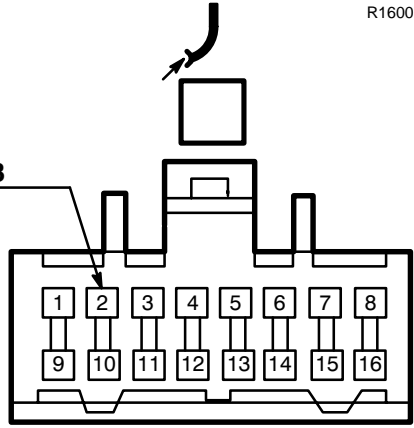

C225



SHORTING LINK 1

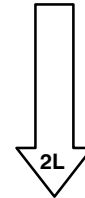

2L

R160002

**CONDITIONS**

- Ignition Switch  
*Position: 0*
- All doors  
*Unlocked*

**RESULTS**  
*Less than 1 ohm*

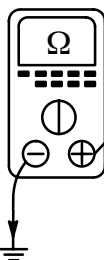

Z163  
Theft Alarm Unit

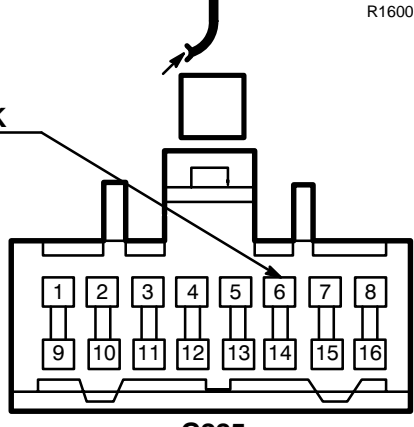

C225

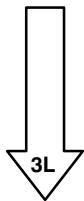

**PROBLEM CAUSE**  
- Theft Alarm Unit

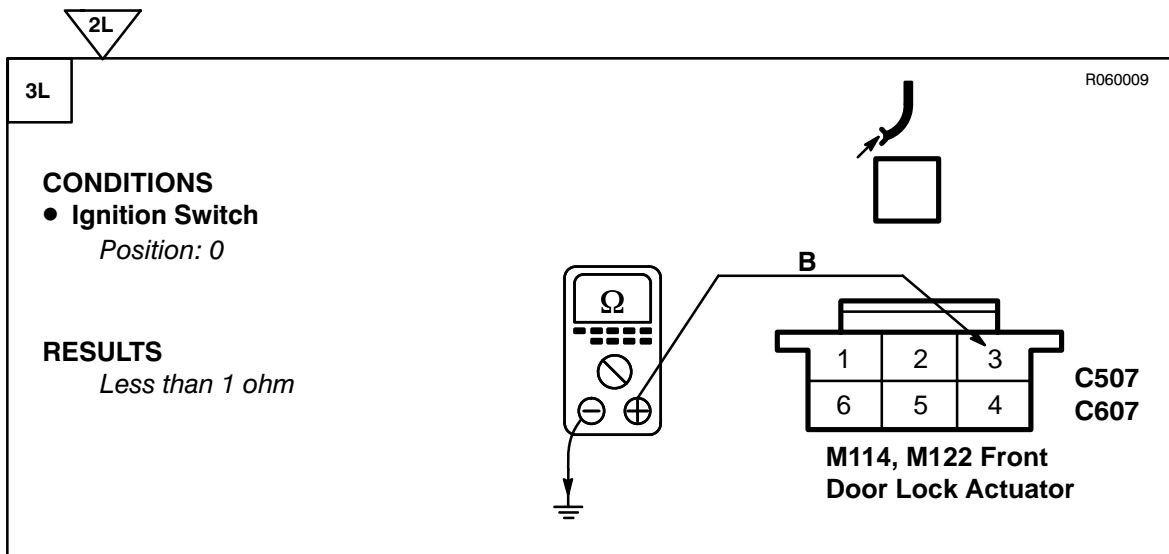

**PROBLEM CAUSE**  
- B Wire

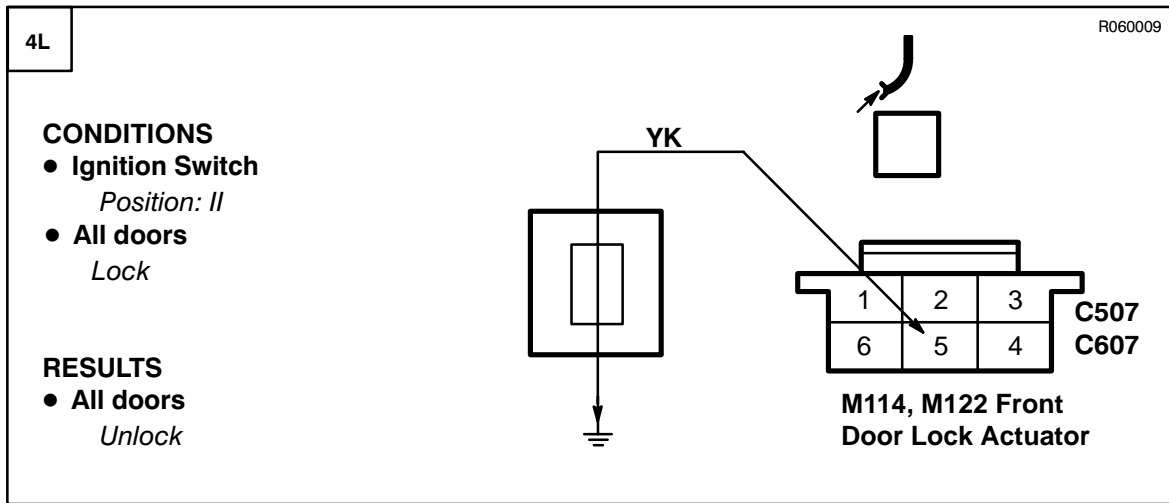
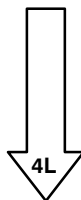

**PROBLEM CAUSE**  
- YK Wire  
- GB Wire  
- Theft Alarm Unit



**PROBLEM CAUSE**  
- M114, M122 Front Door Lock Actuator

### Test M

R020029

1M

**CONDITIONS**

- Ignition Switch  
*Position: 0*
- All doors  
*Unlocked*
- Lock a front door

**RESULTS**  
*BAT VOLT (Momentary)*

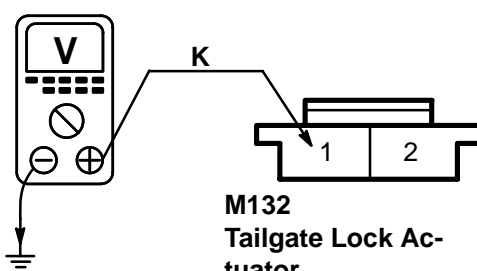

**M132**  
Tailgate Lock Ac-  
tuator



~~OK~~ PROBLEM CAUSE  
- K Wire

OK

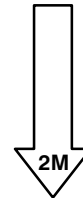

R020029

2M

**CONDITIONS**

- Ignition Switch  
*Position: 0*
- All doors  
*Locked*
- Unlock a front door

**RESULTS**  
*BAT VOLT (Momentary)*

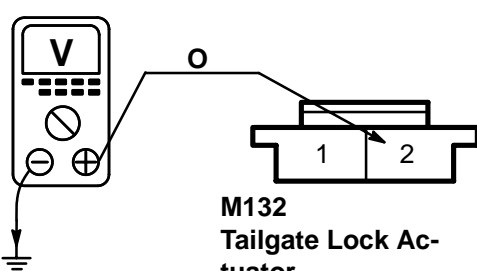

**M132**  
Tailgate Lock Ac-  
tuator



~~OK~~ PROBLEM CAUSE  
- O Wire

OK PROBLEM CAUSE  
- Tailgate Lock Ac-  
tuator

**Test N**

R020029

1N

**CONDITIONS**

- Ignition Switch  
*Position: 0*
- All doors  
*Unlocked*
- Lock a front door

**RESULTS**  
*BAT VOLT (Momentary)*

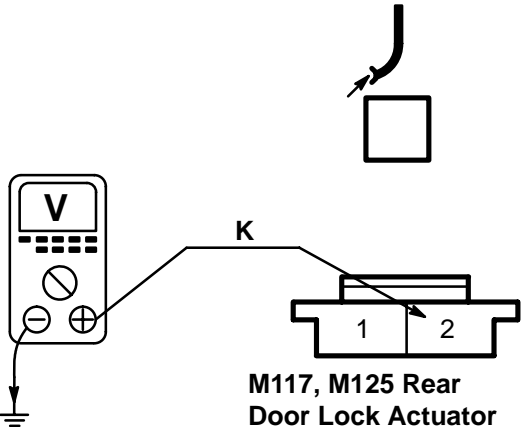

M117, M125 Rear  
Door Lock Actuator

C706  
C806



**PROBLEM CAUSE**  
- K Wire

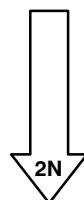

R020029

2N

**CONDITIONS**

- Ignition Switch  
*Position: 0*
- All doors  
*Locked*
- Unlock a front door

**RESULTS**  
*BAT VOLT (Momentary)*

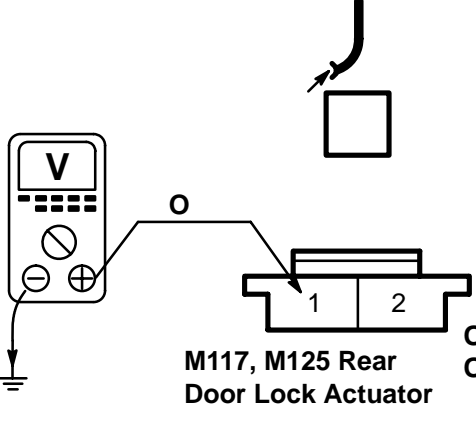

M117, M125 Rear  
Door Lock Actuator

C706  
C806



**PROBLEM CAUSE**  
- O Wire



**PROBLEM CAUSE**  
- M117, M125 Rear  
Door Lock Actuator



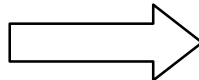
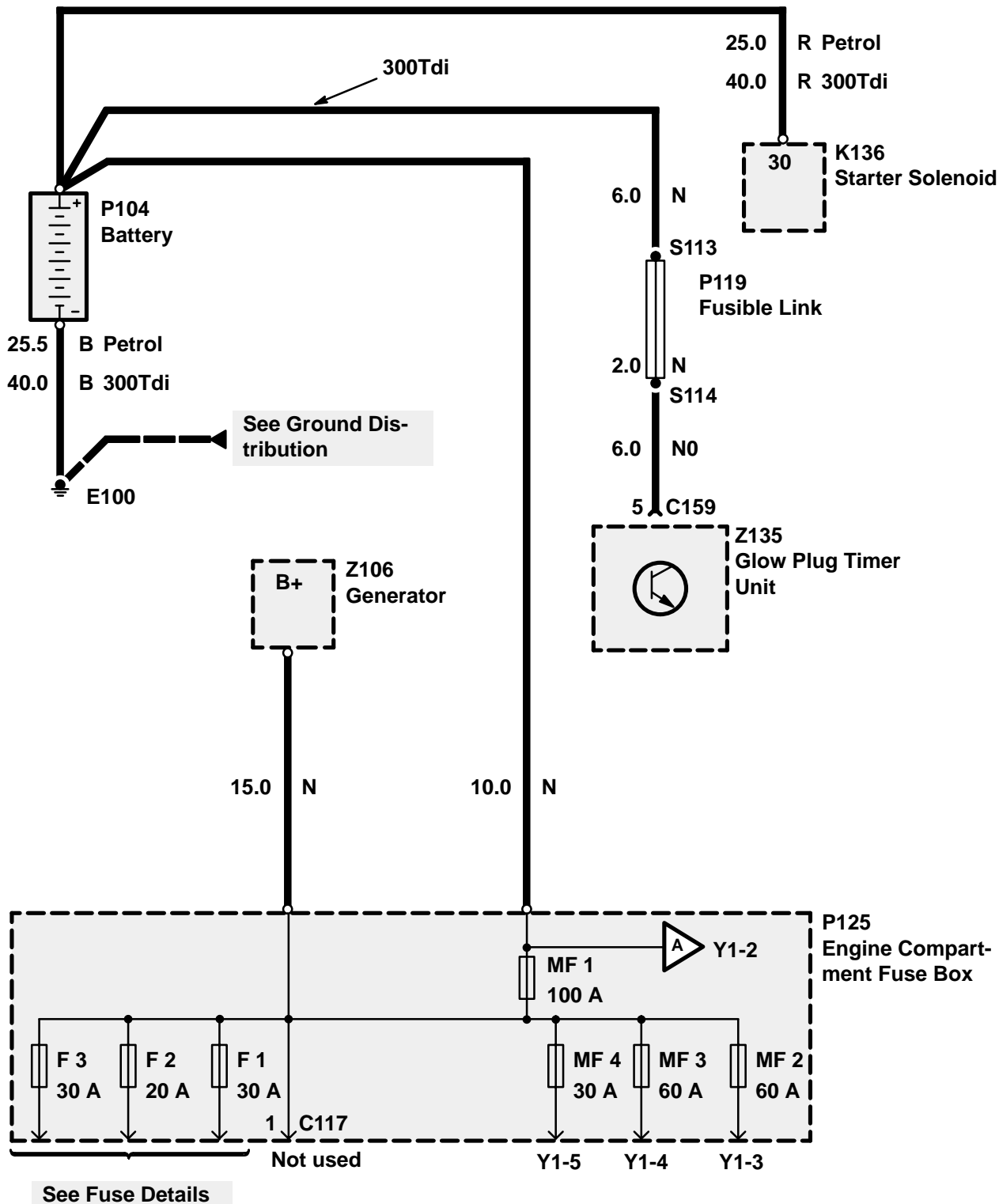

# Y1 ETM

## DISCOVERY

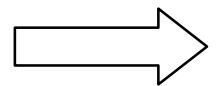
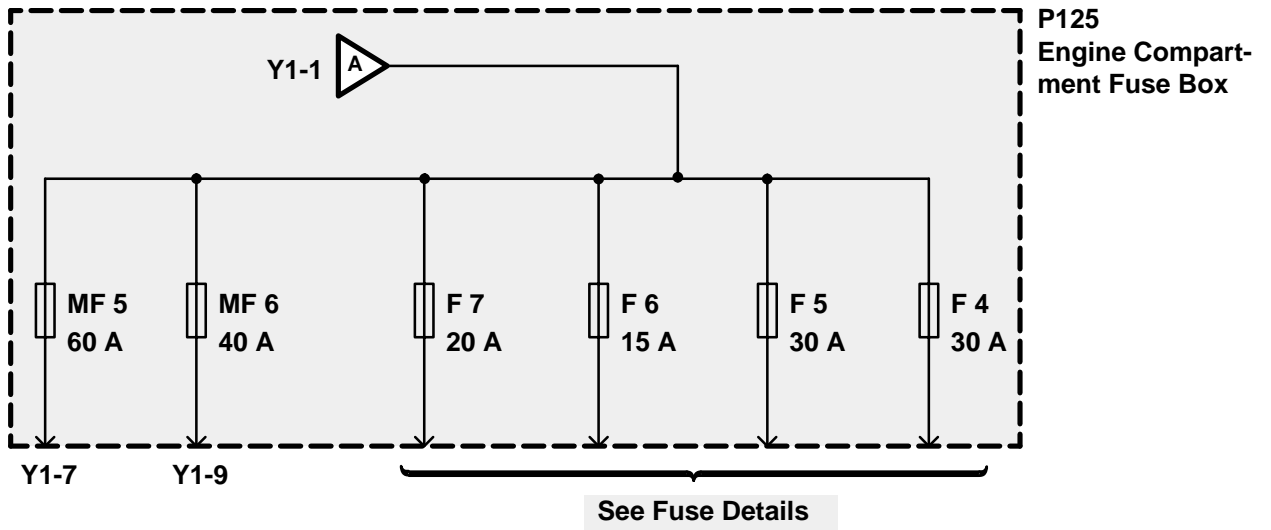
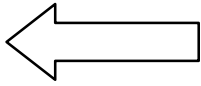

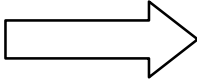
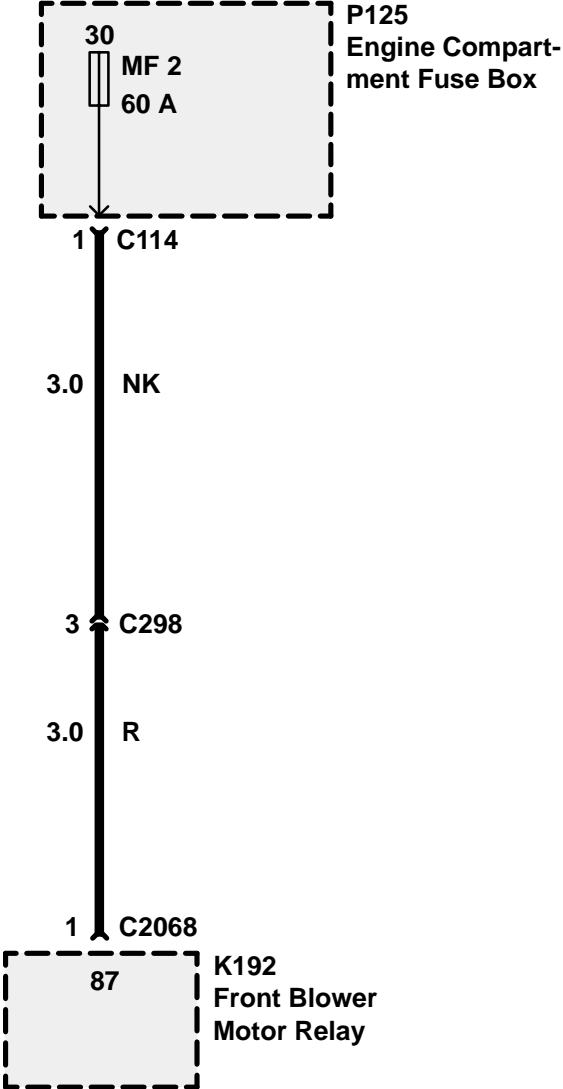
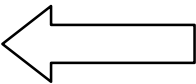

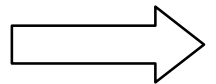
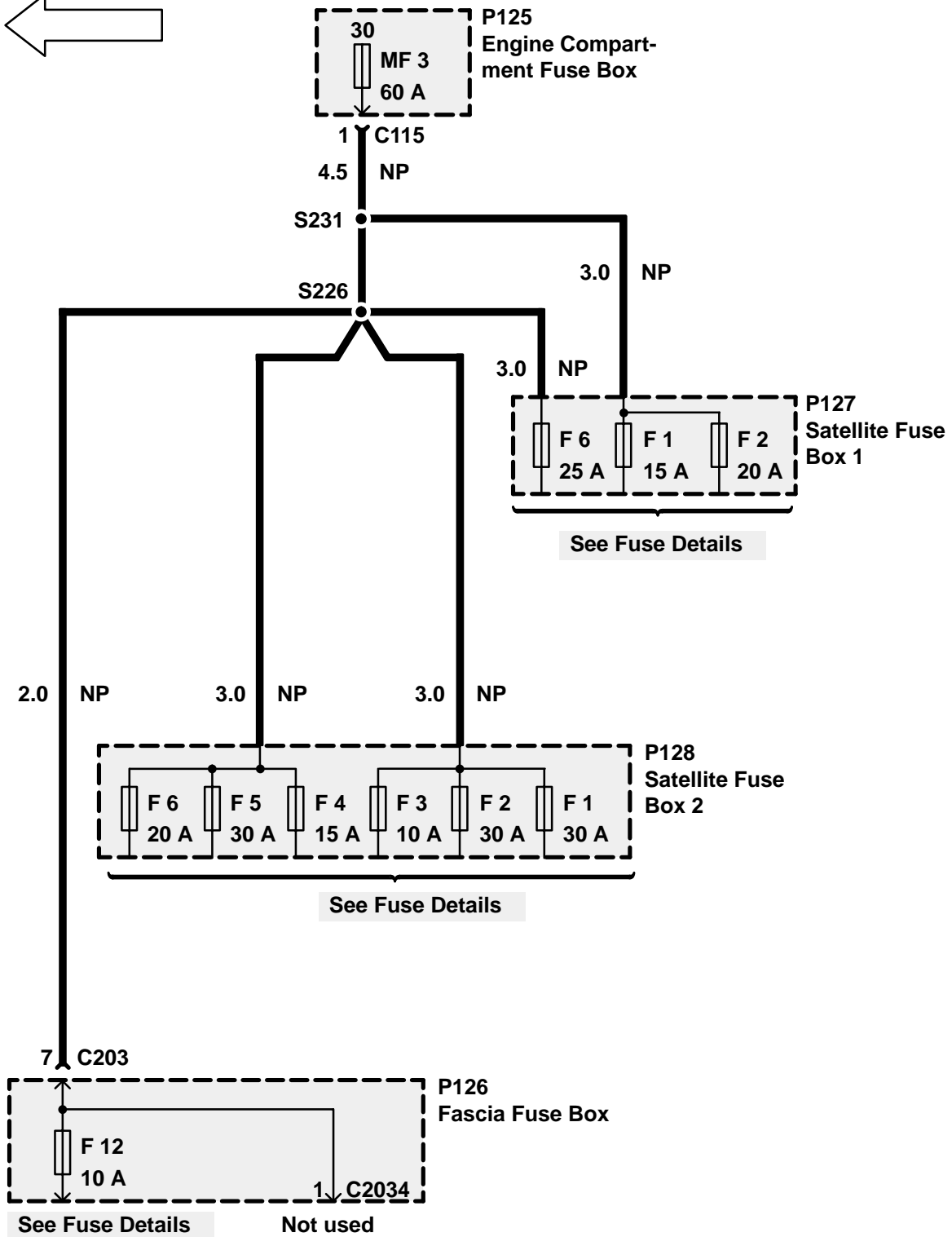
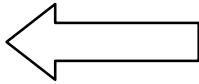

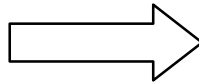
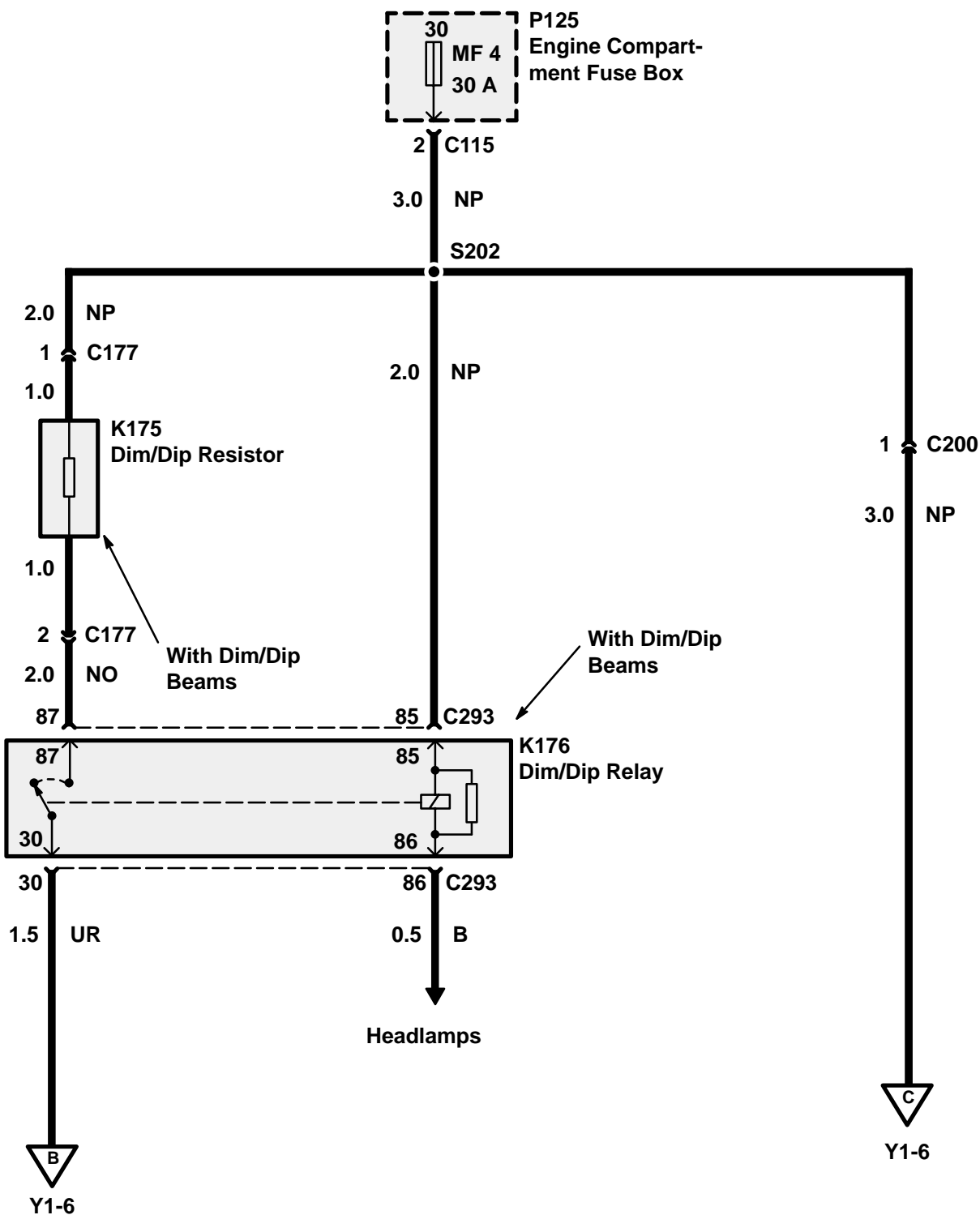
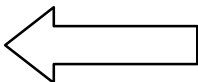

# Y1 ETM

## DISCOVERY

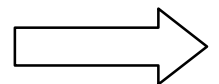
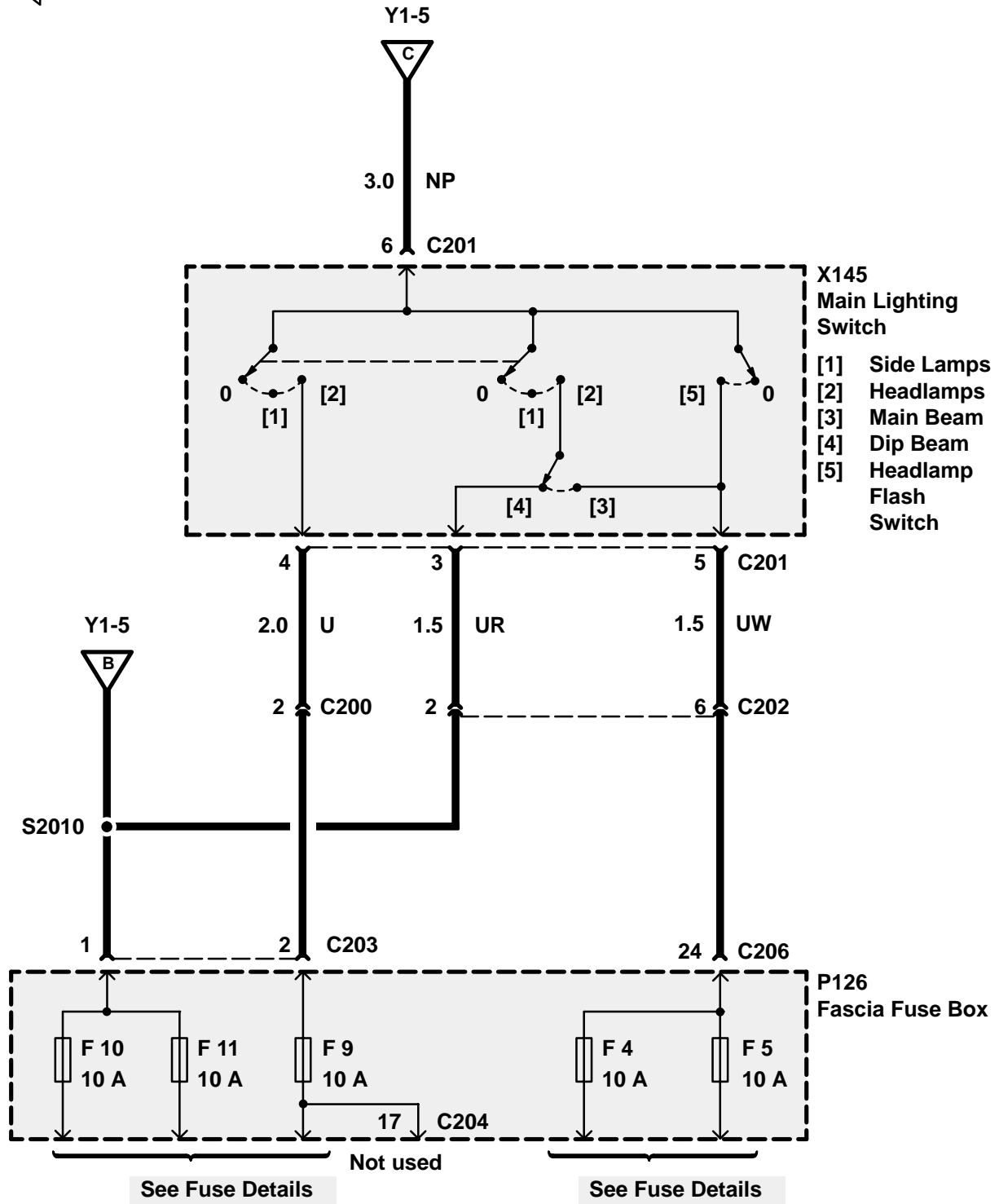
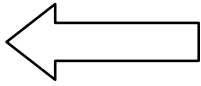



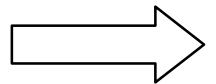
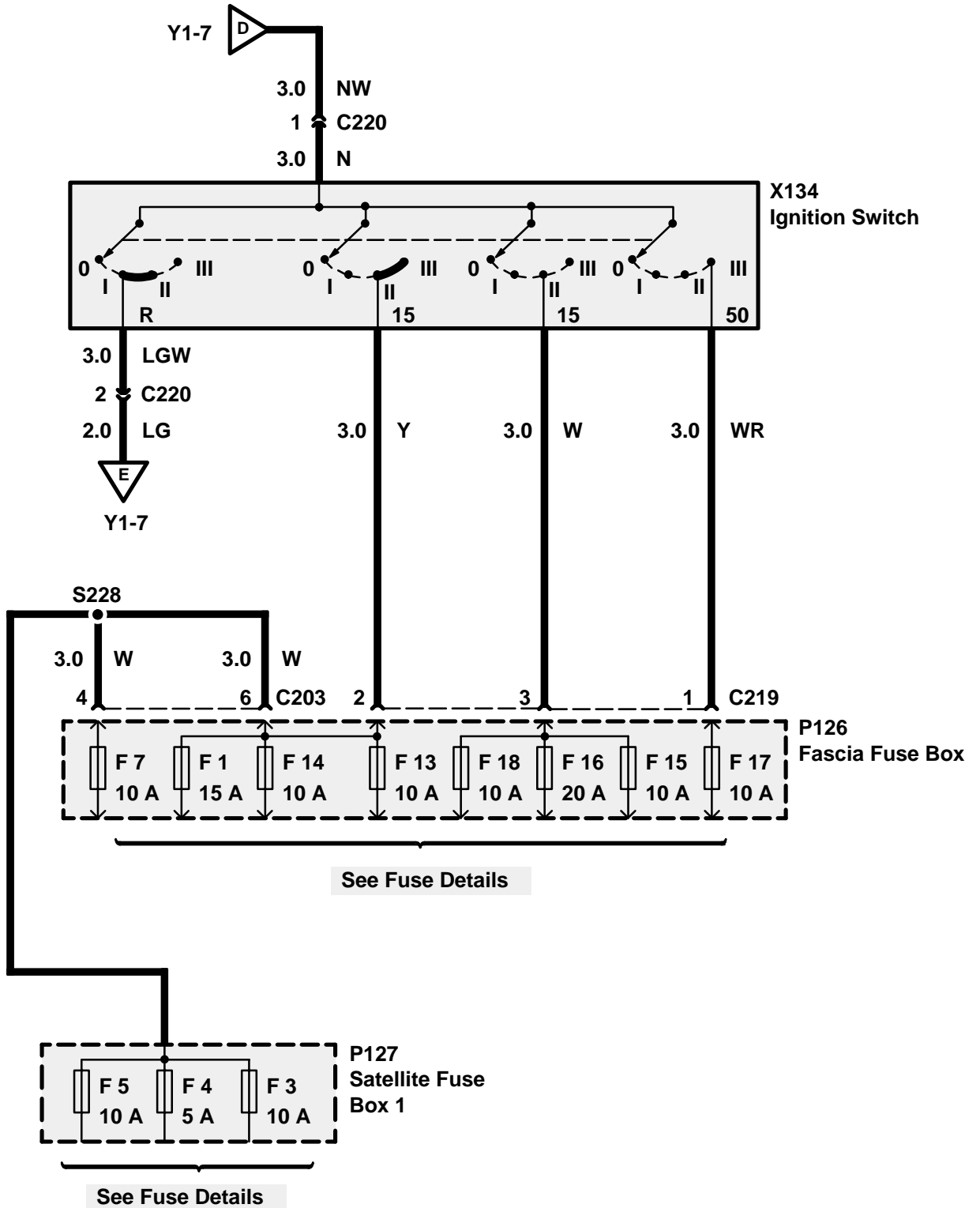
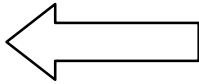



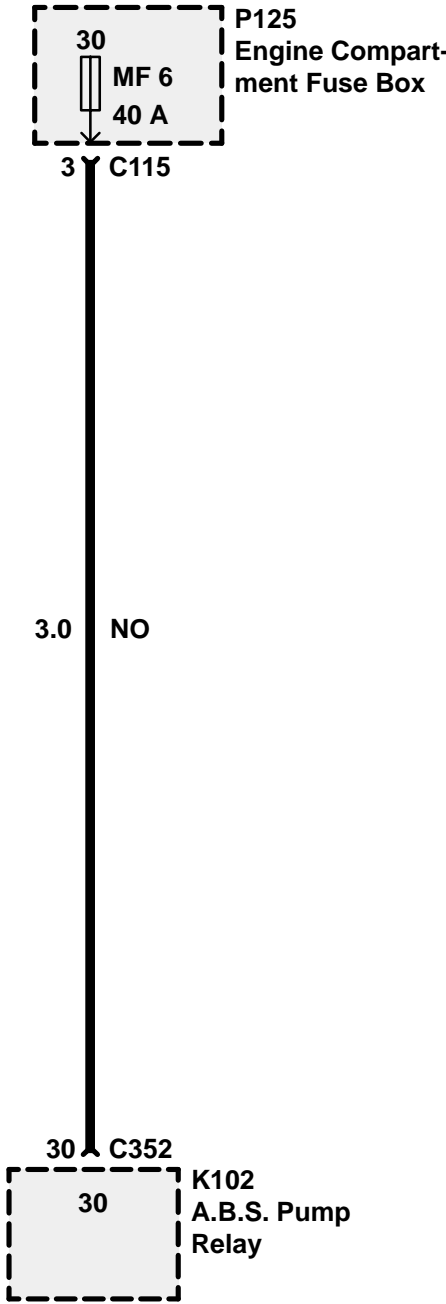
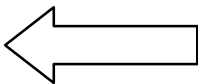

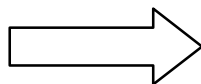
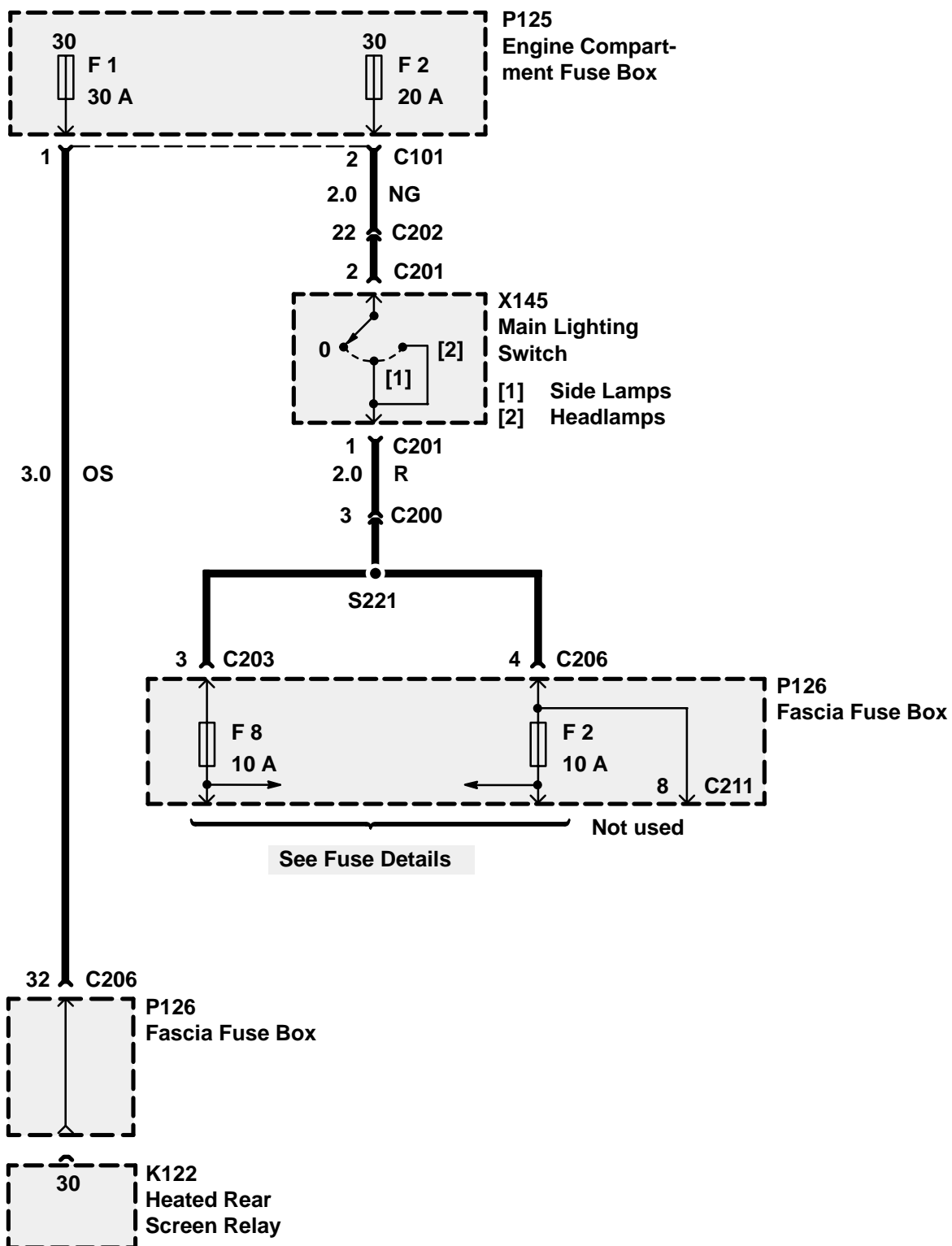

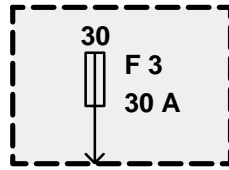
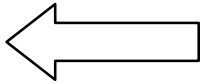

P125  
Engine Compartment Fuse Box

With Air Conditioning

Without Air Conditioning

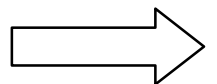
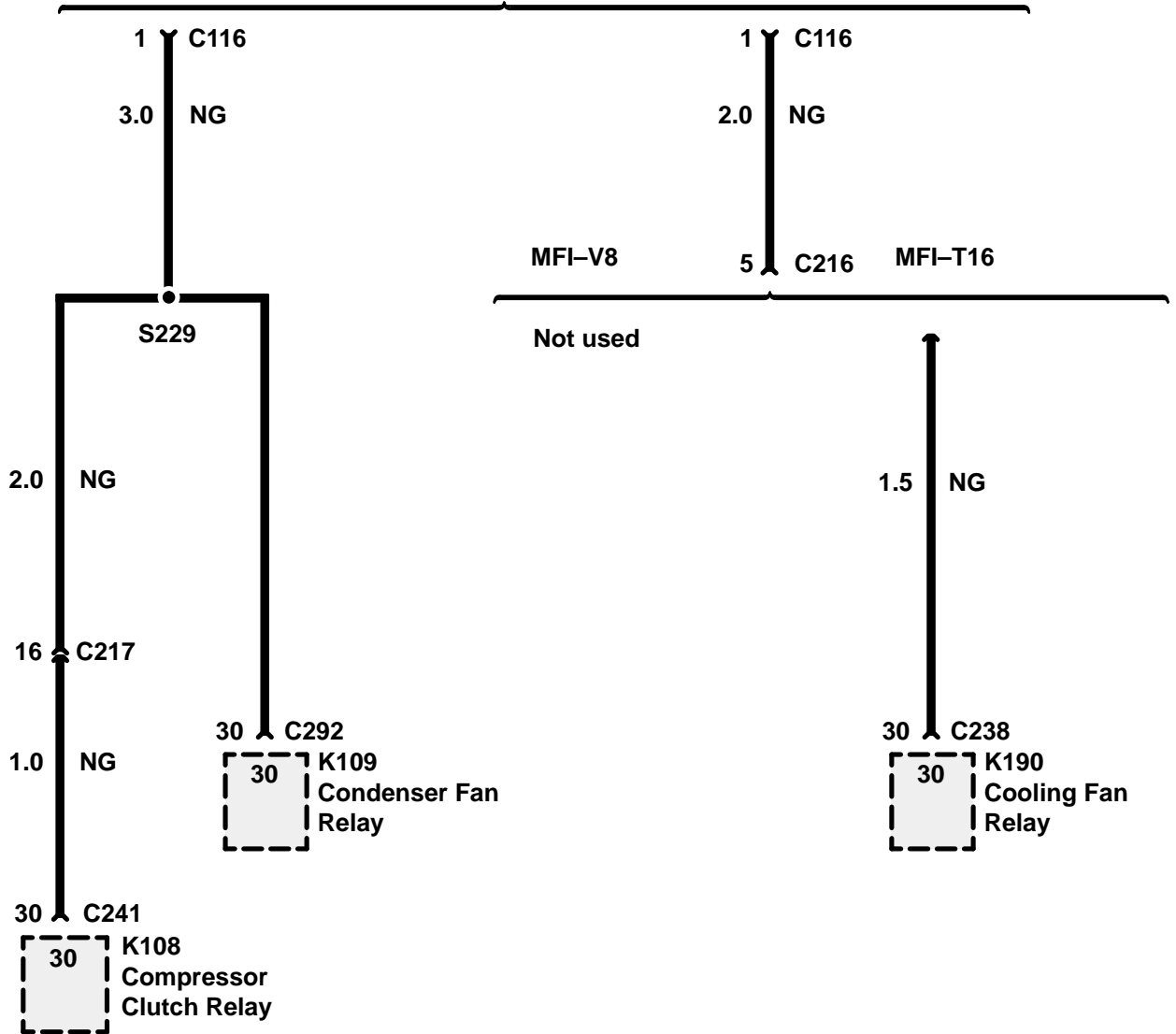

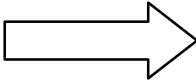
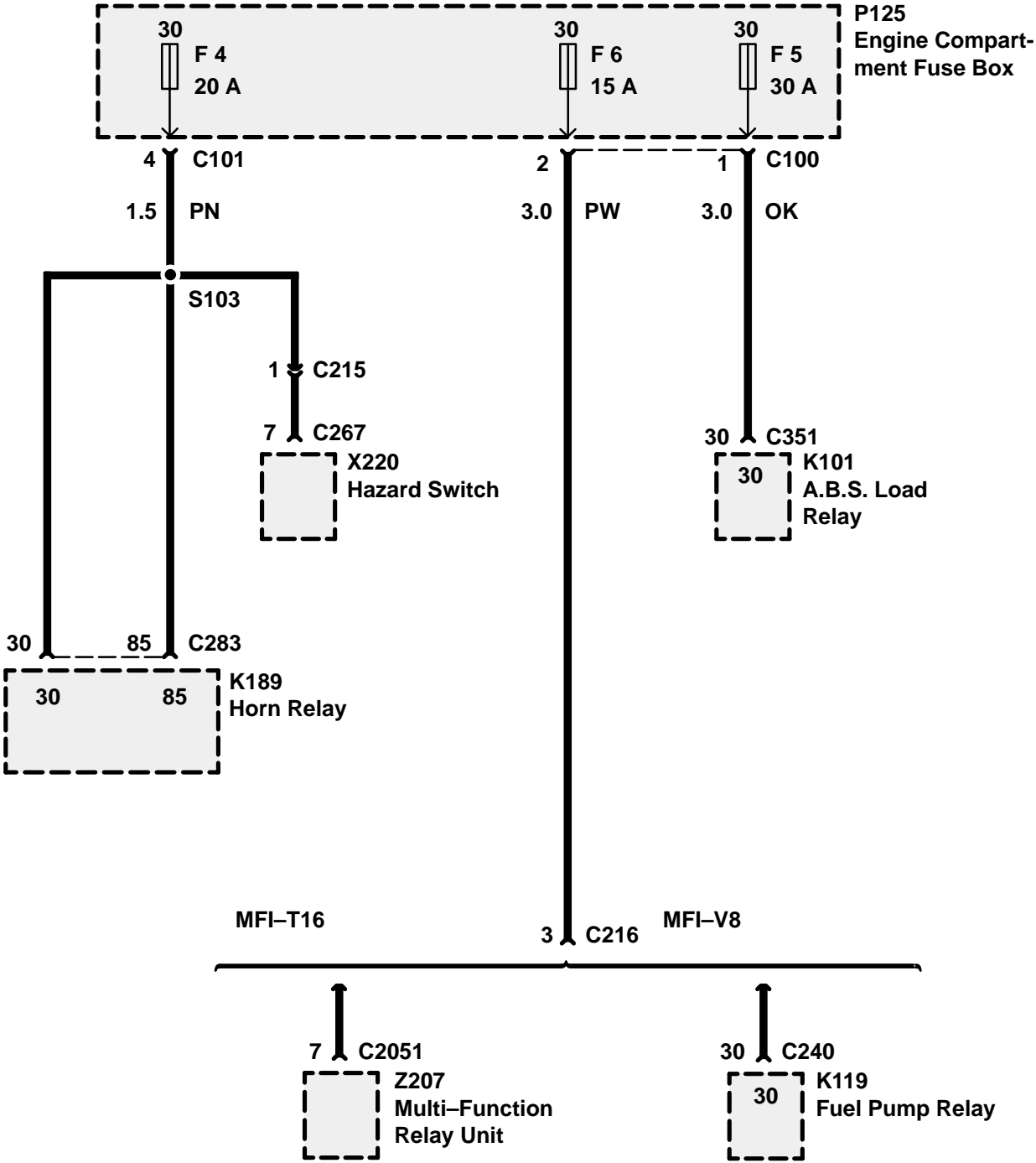
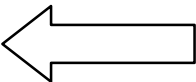

# Y2 ETM

## DISCOVERY

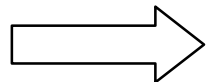
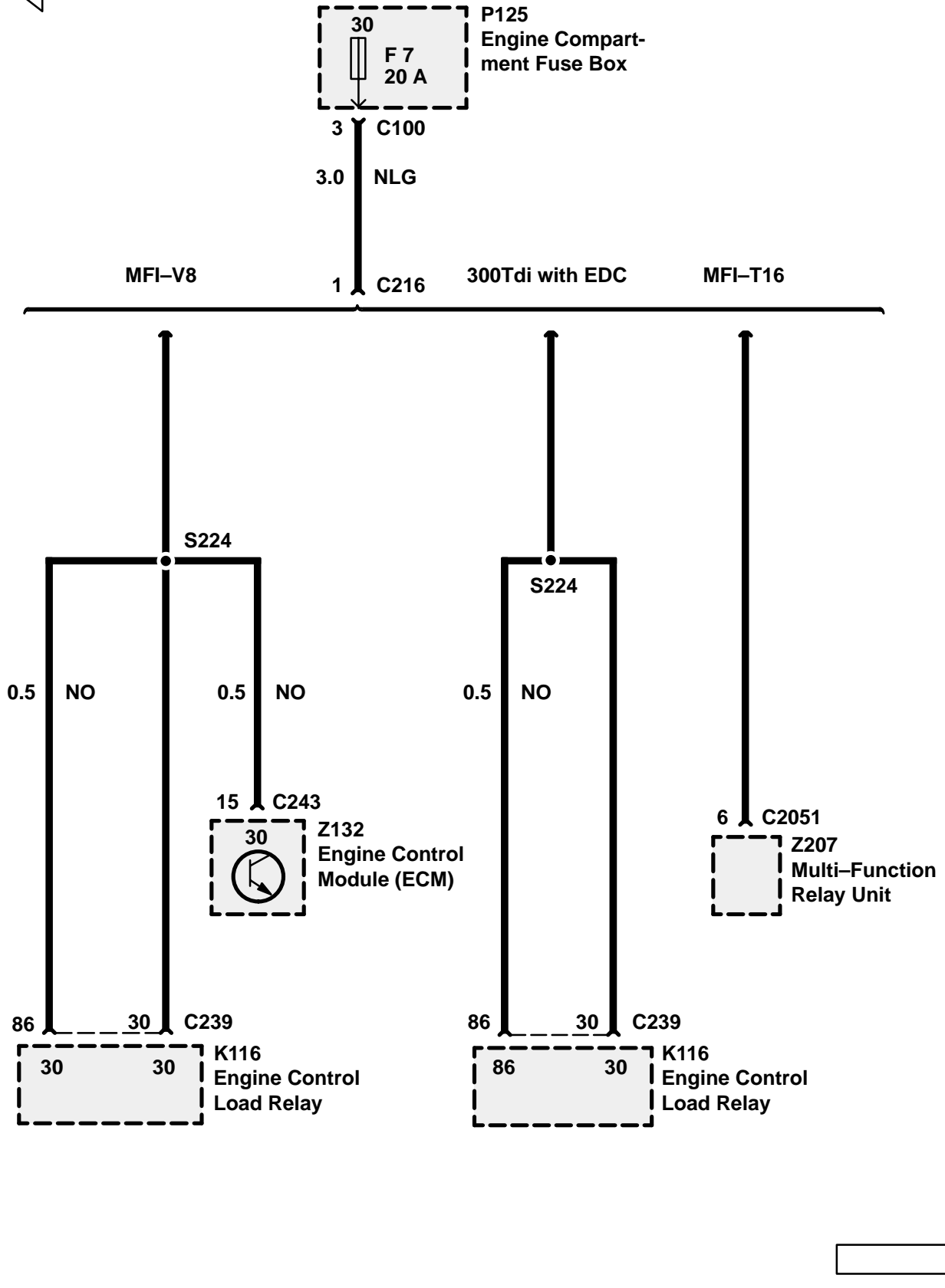
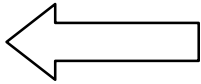

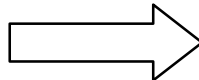
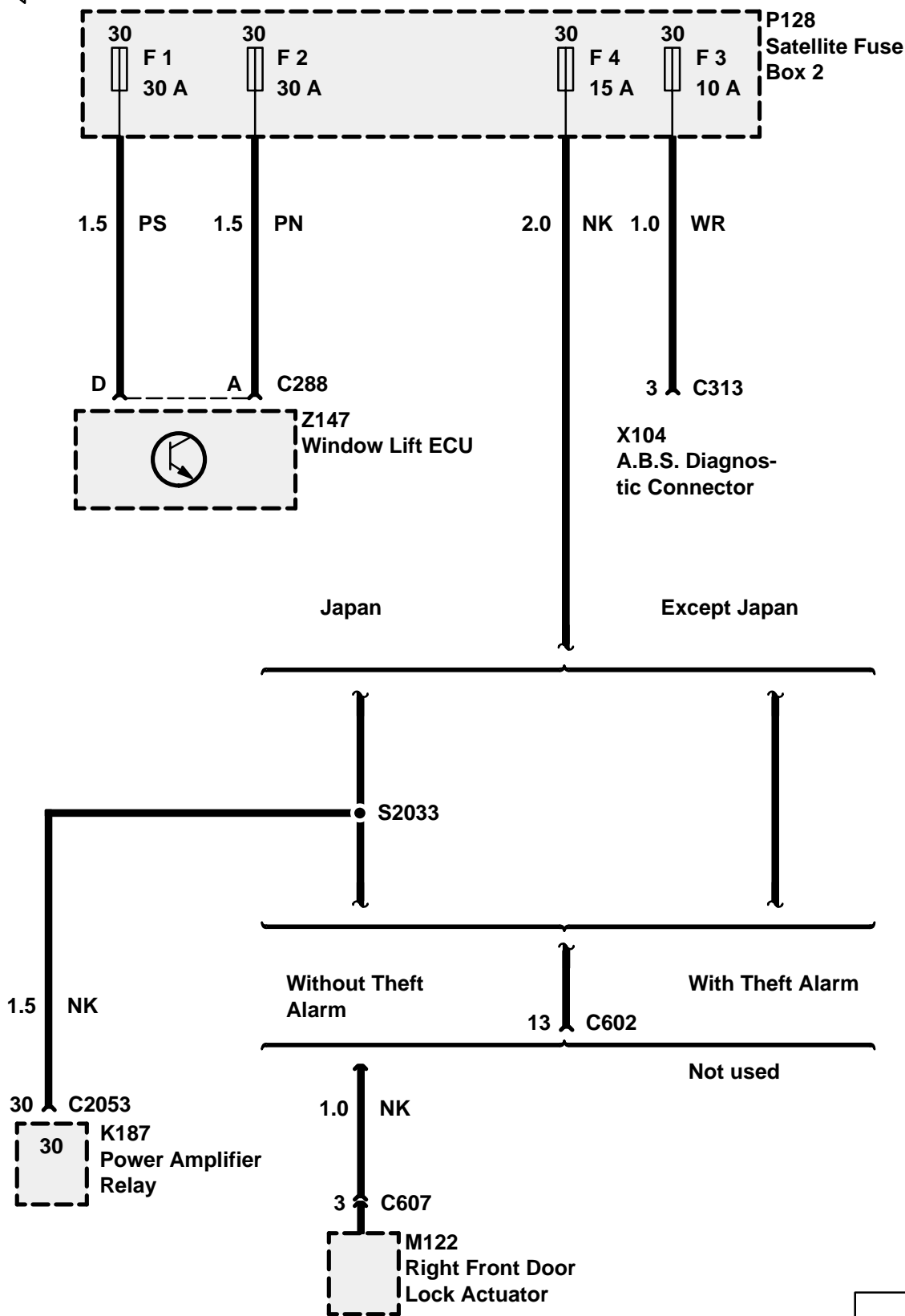
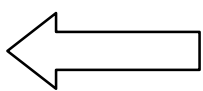

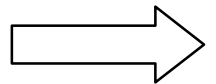
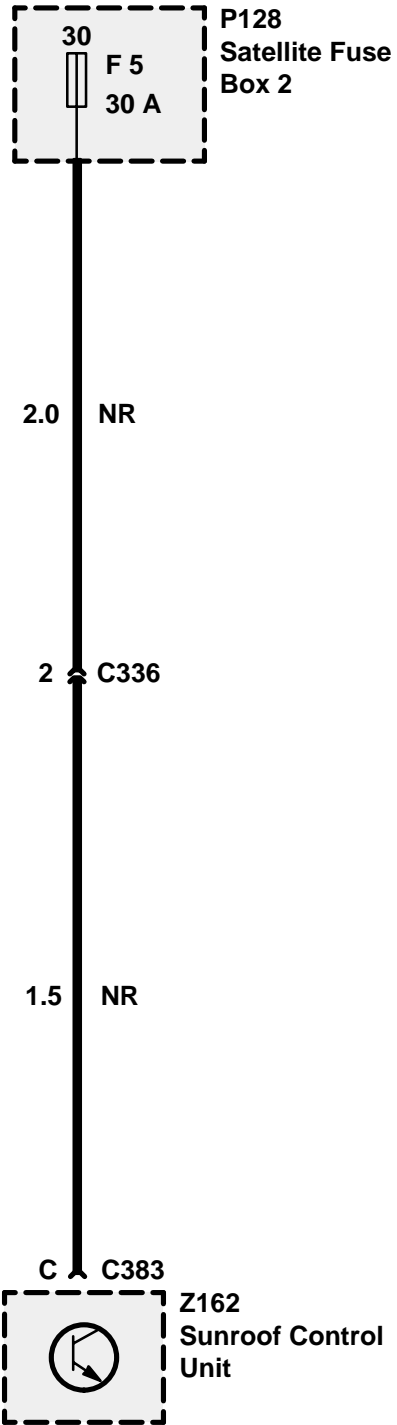
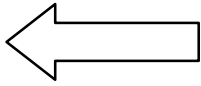

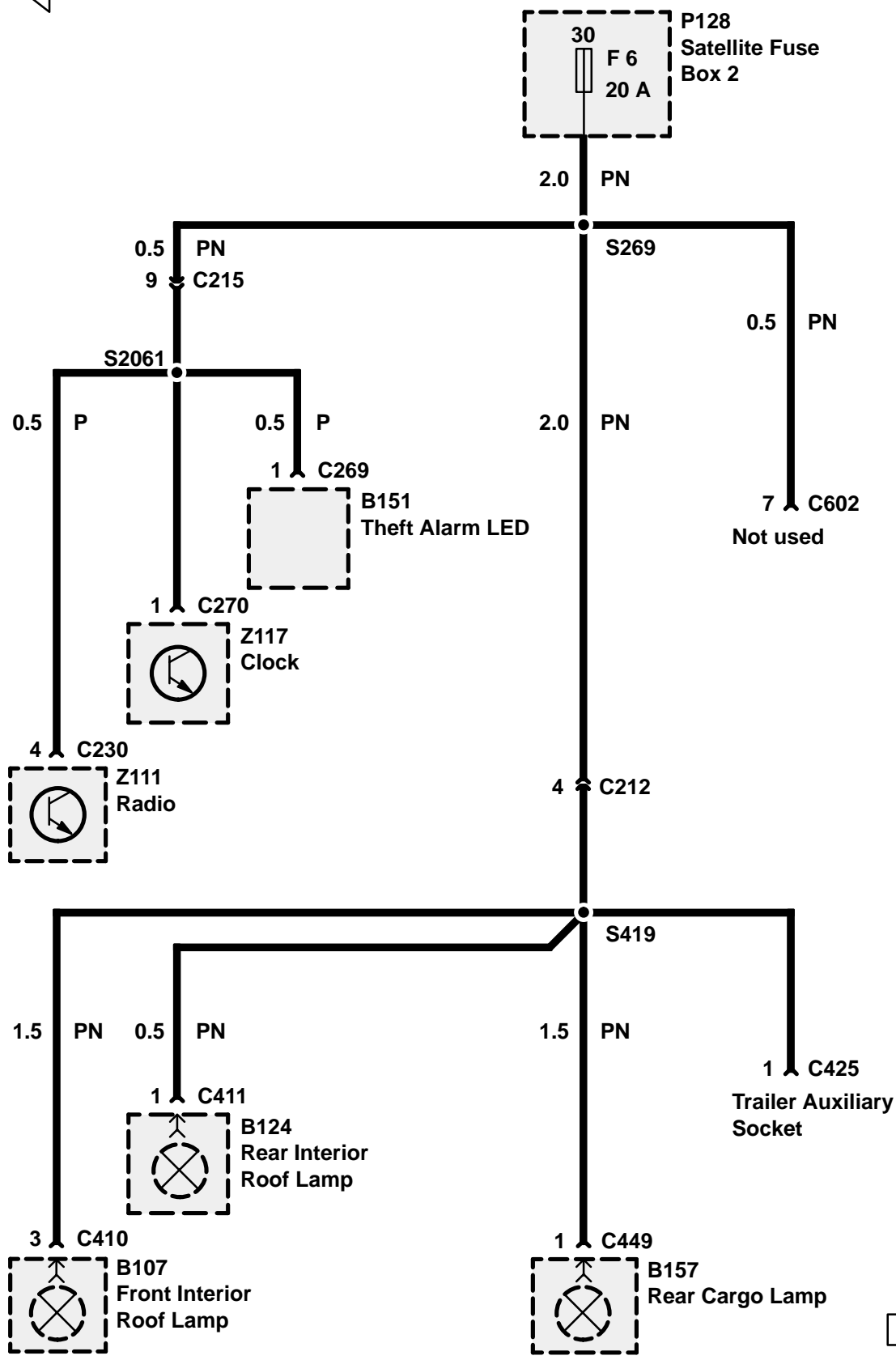
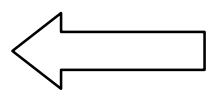



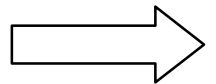
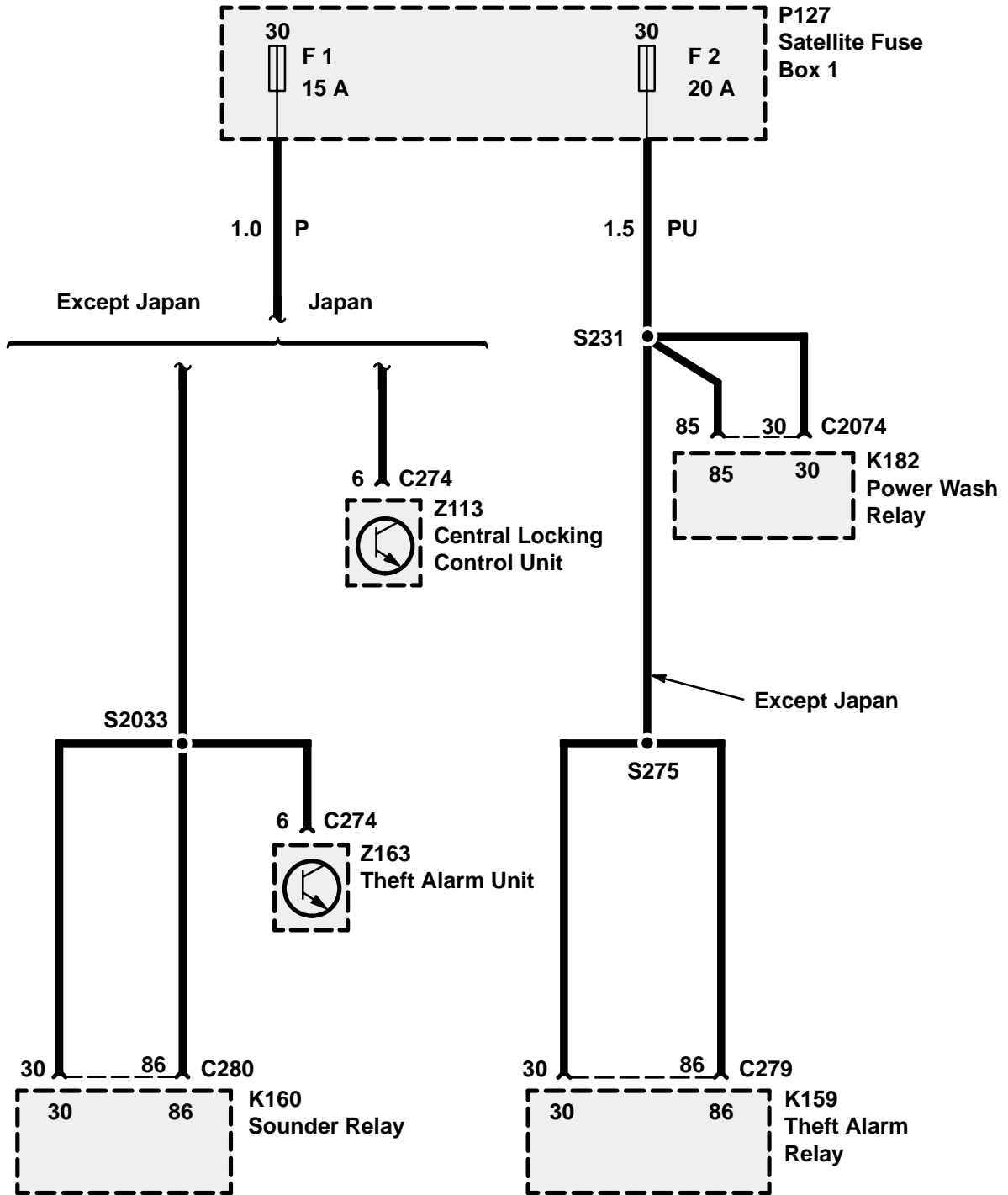
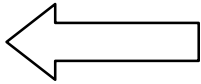

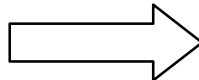
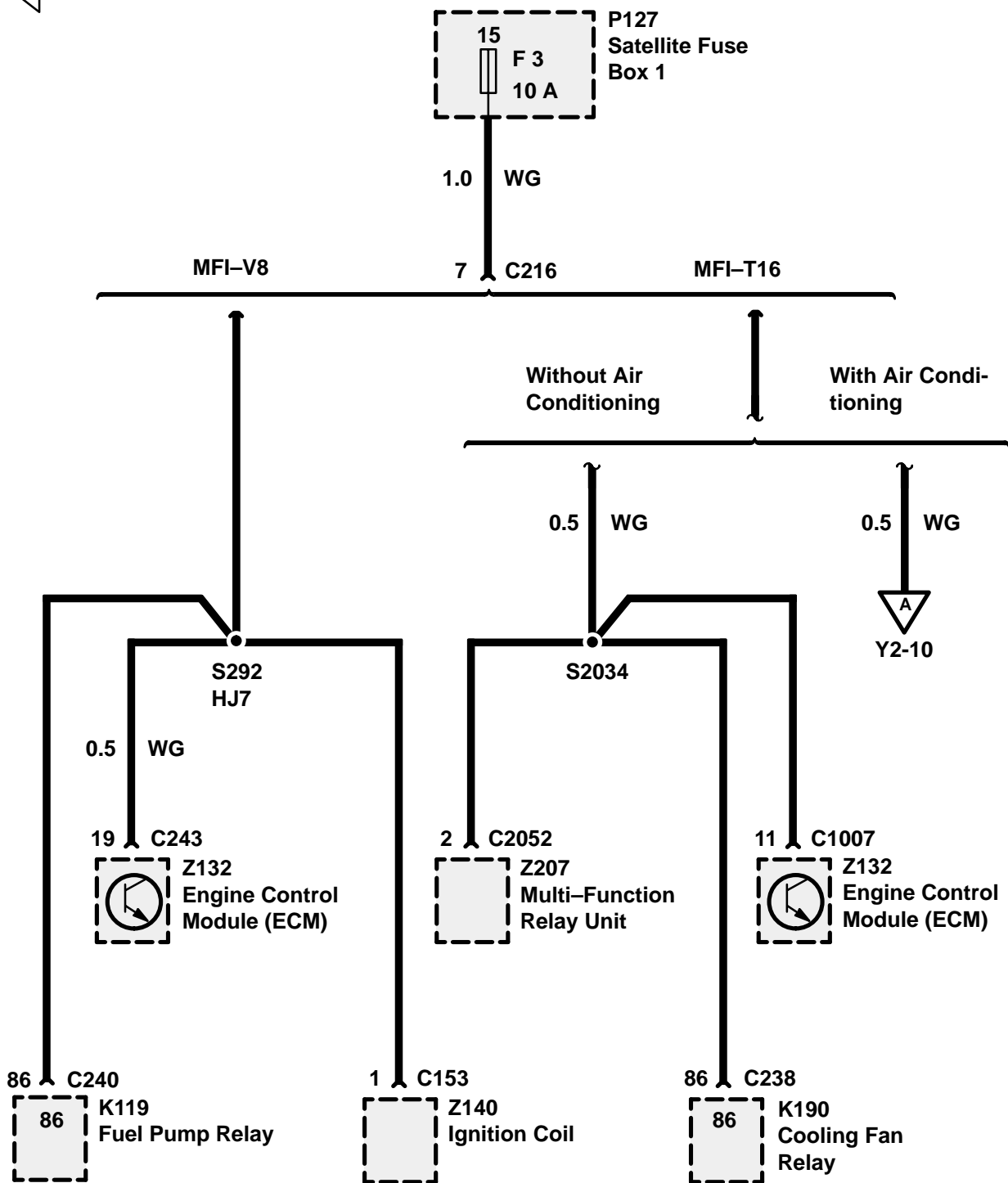
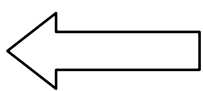

# Y2 ETM

## DISCOVERY

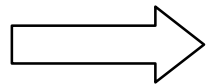
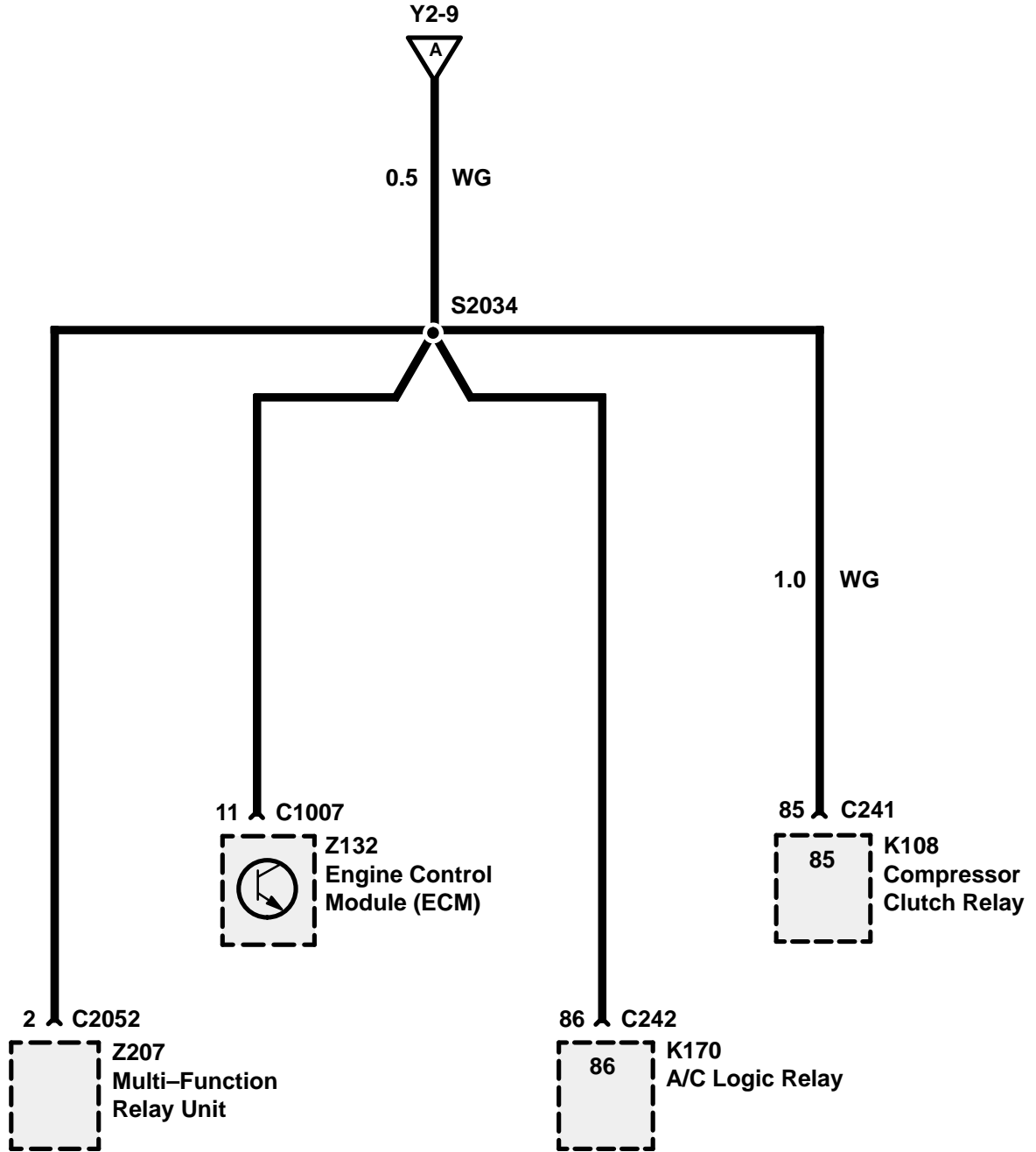
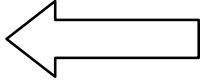



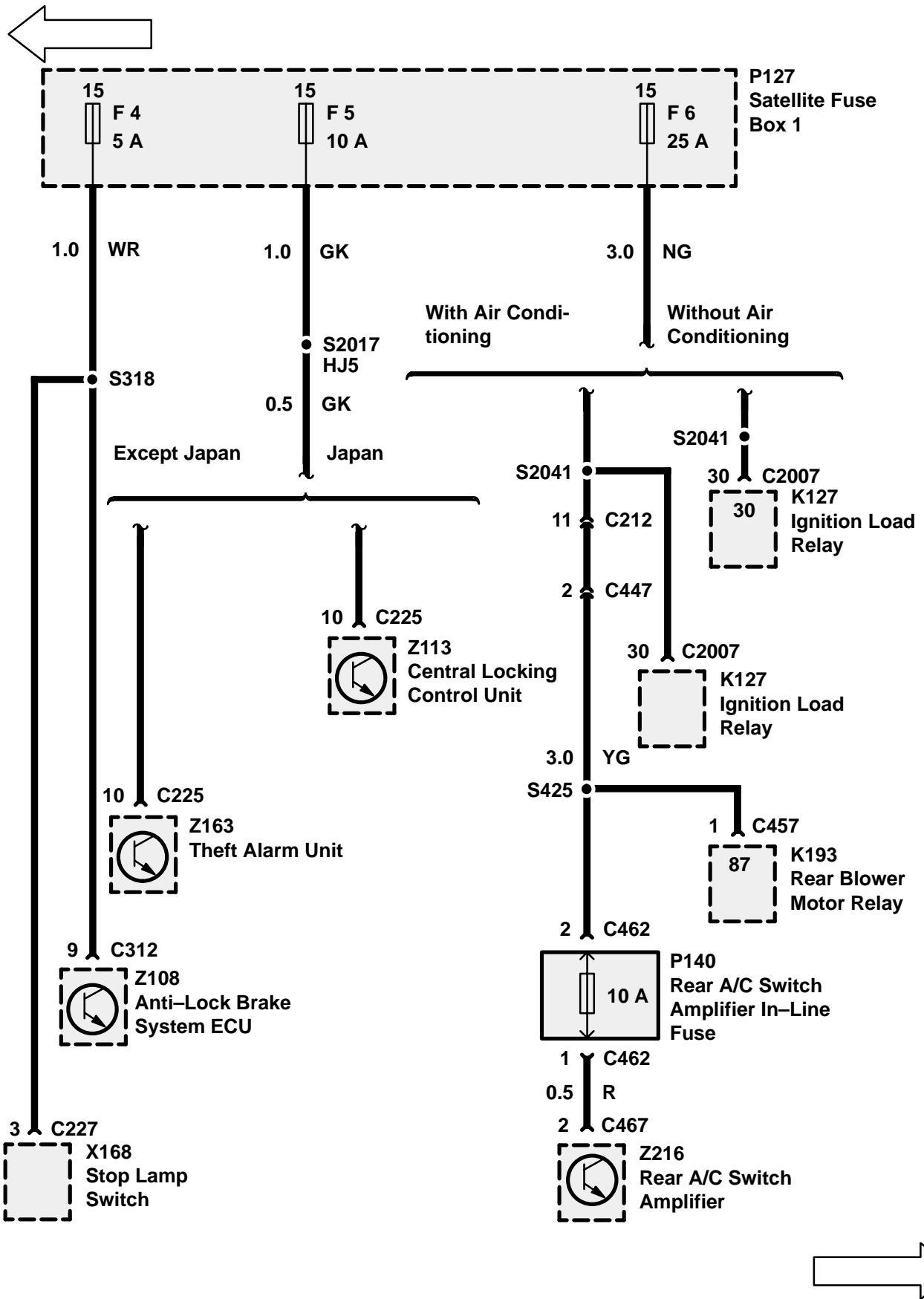

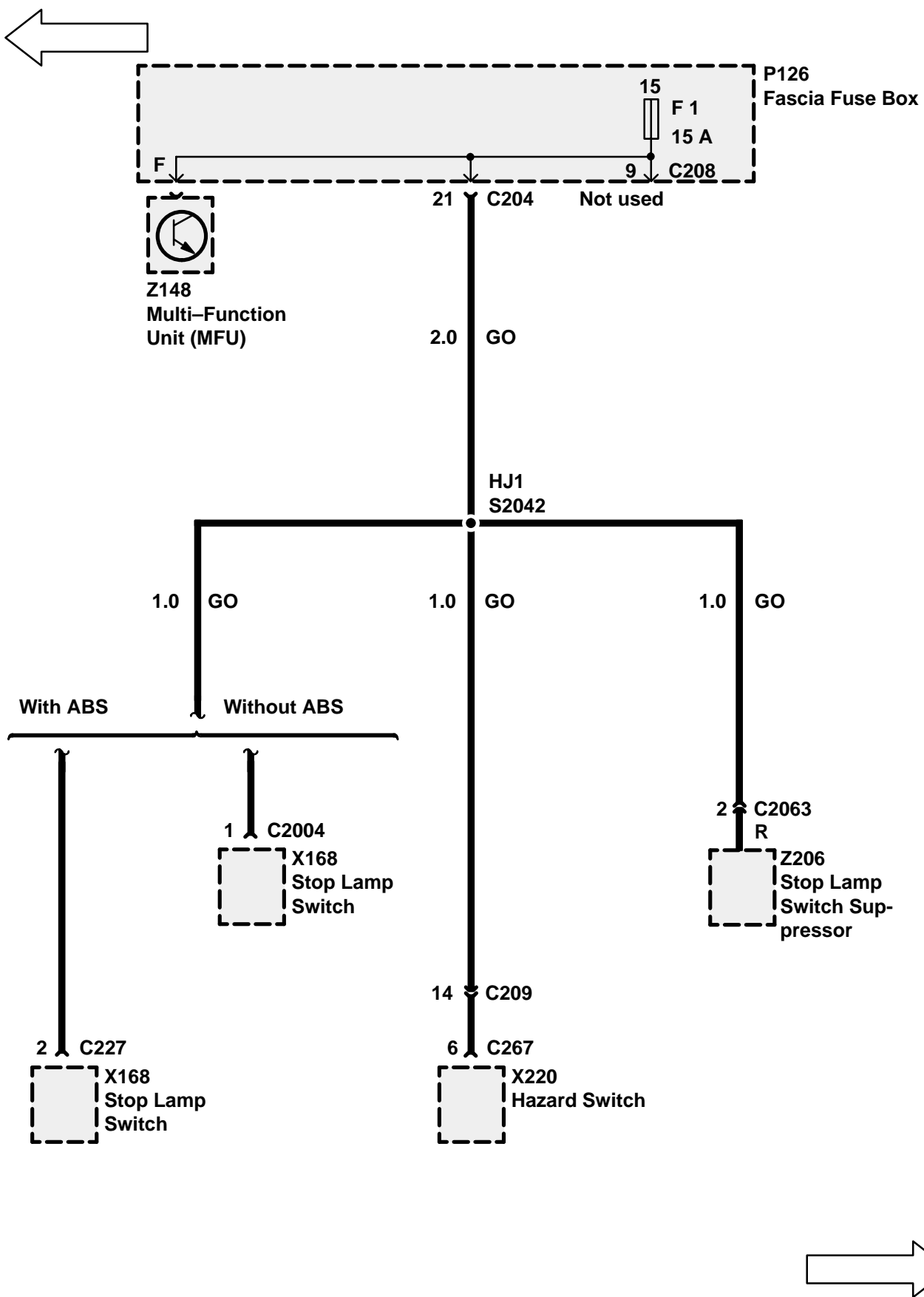

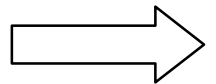
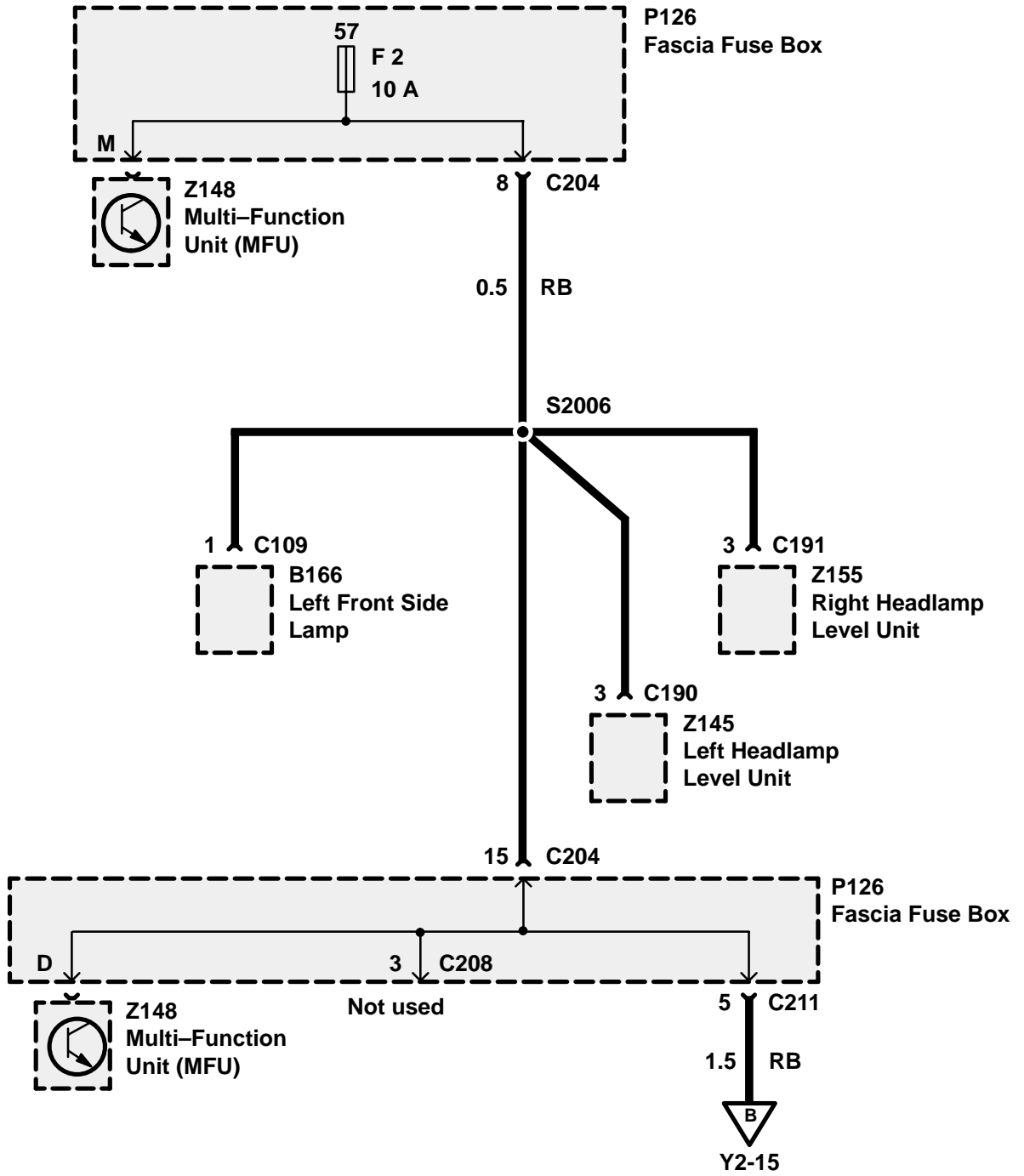
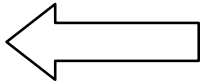

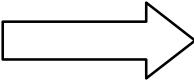
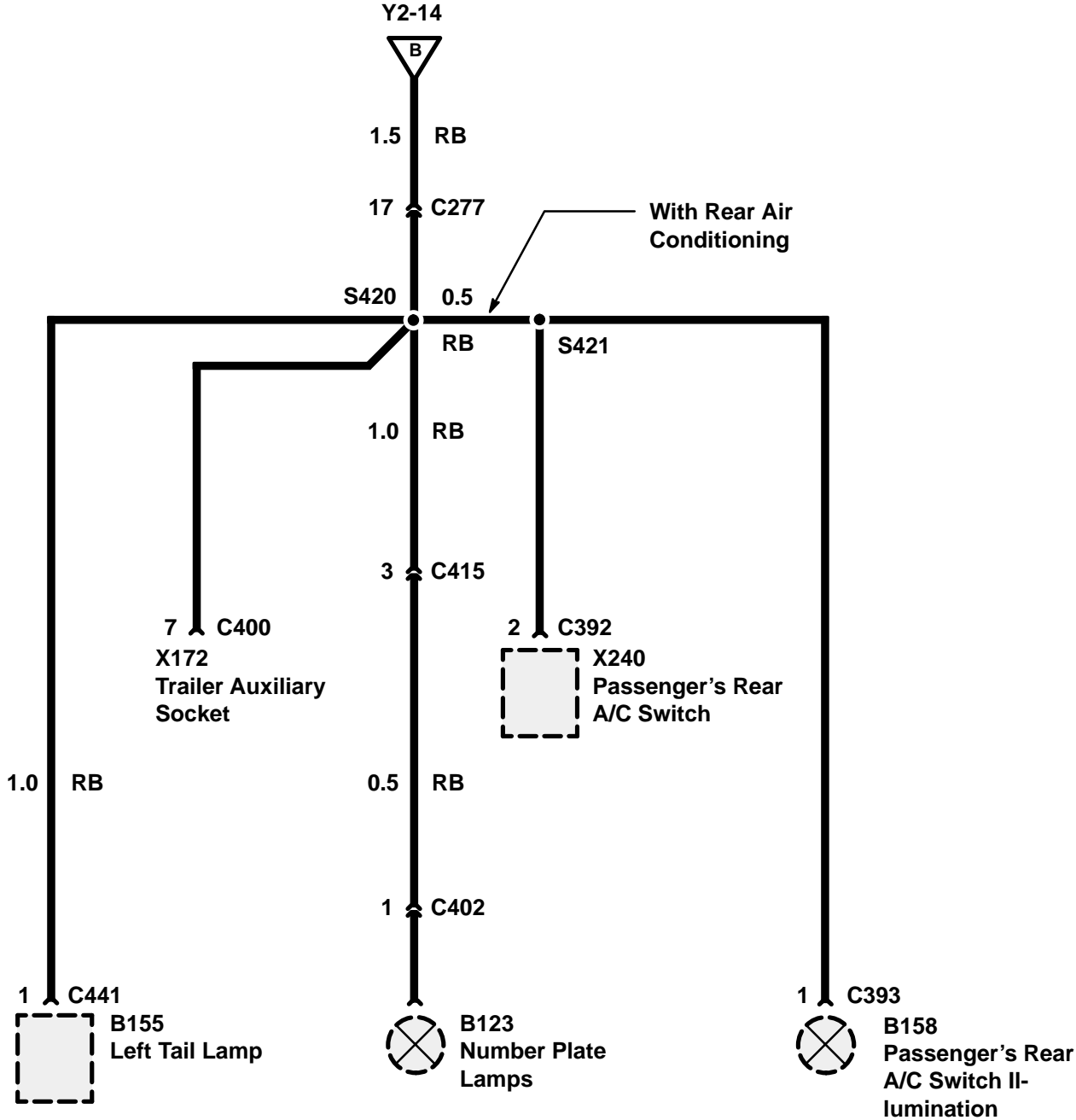
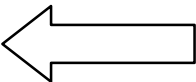



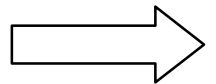
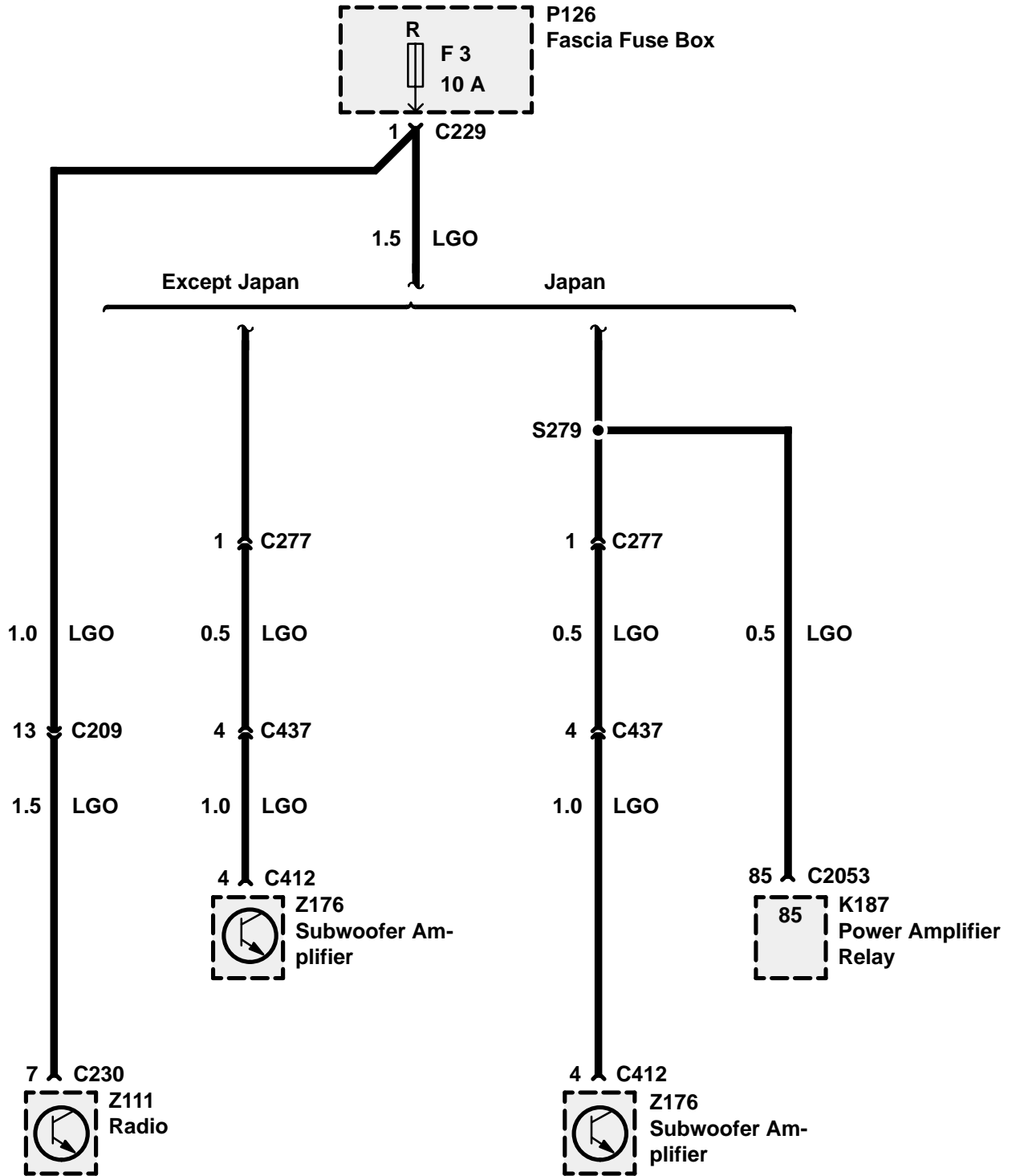
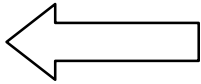

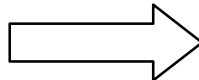
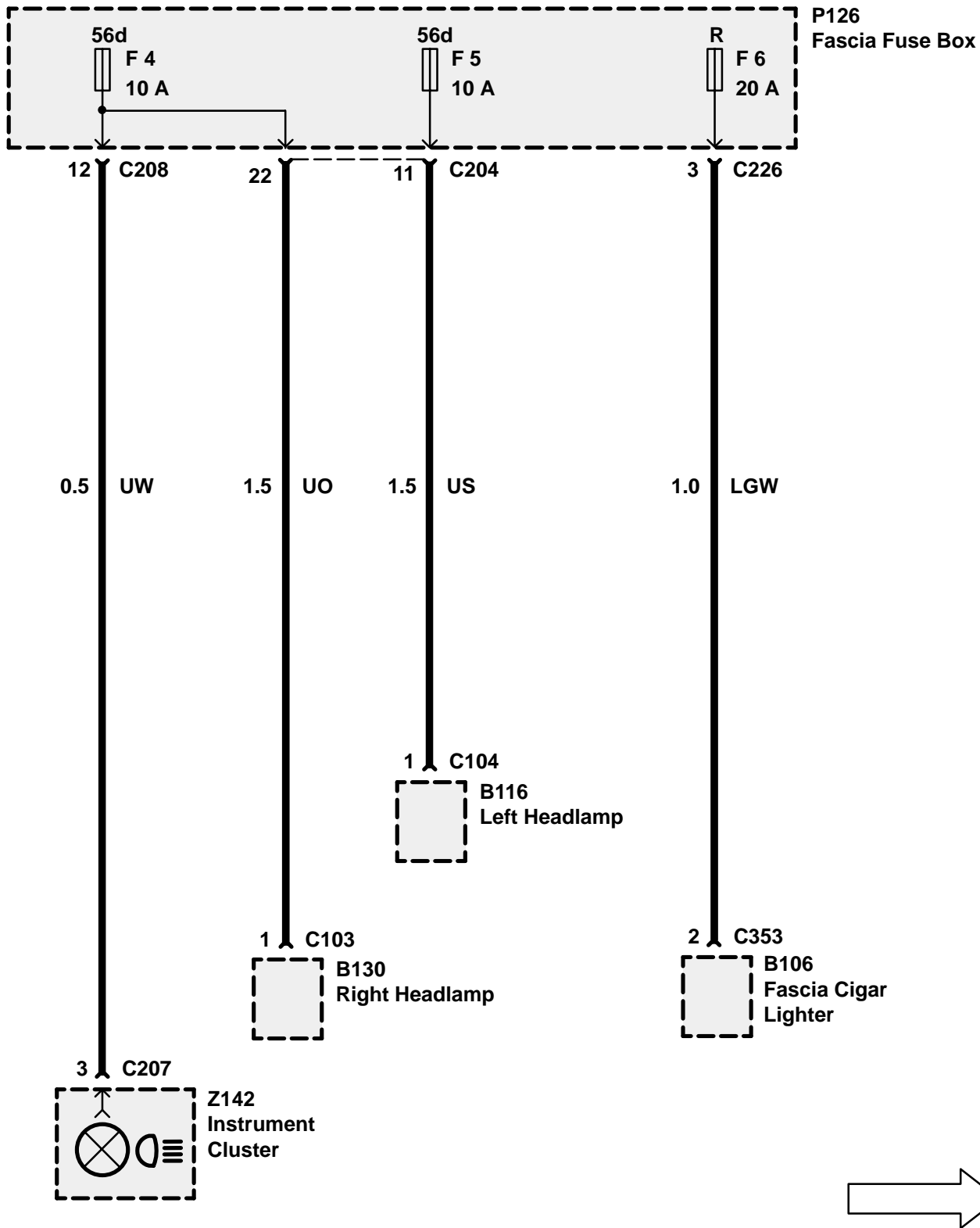
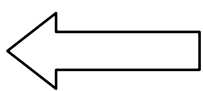

# Y2 ETM

## DISCOVERY

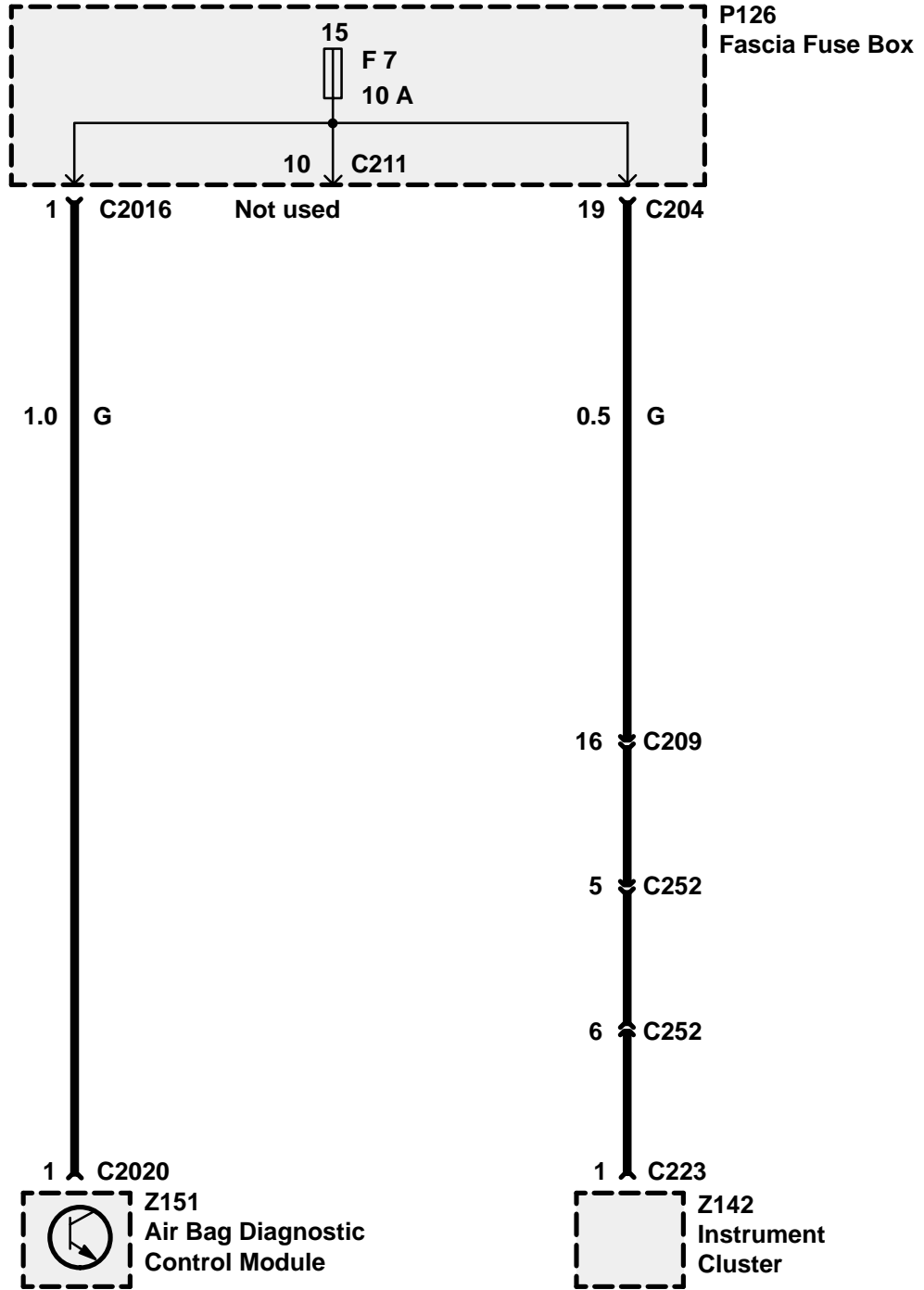

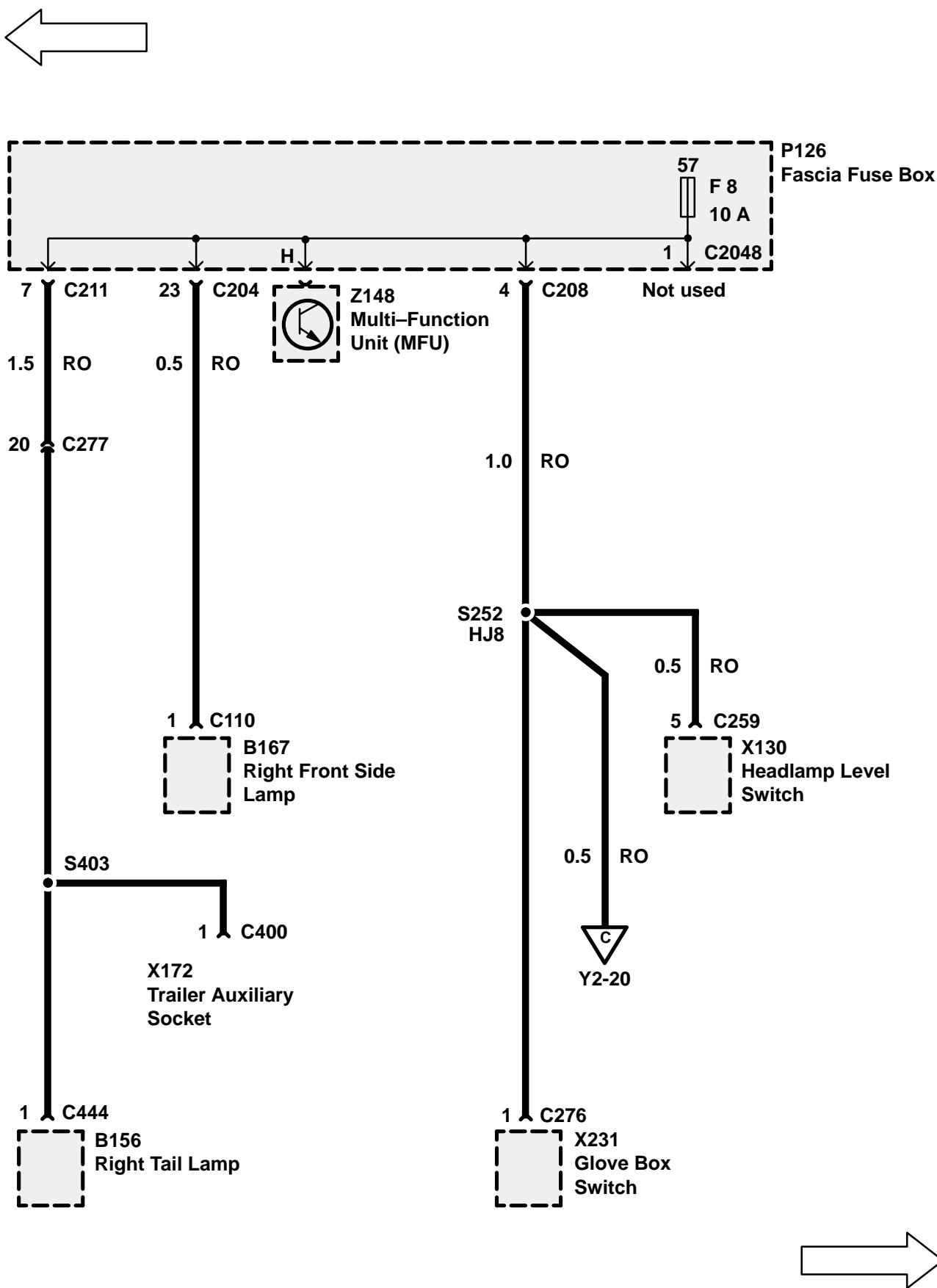

# Y2 ETM

## DISCOVERY

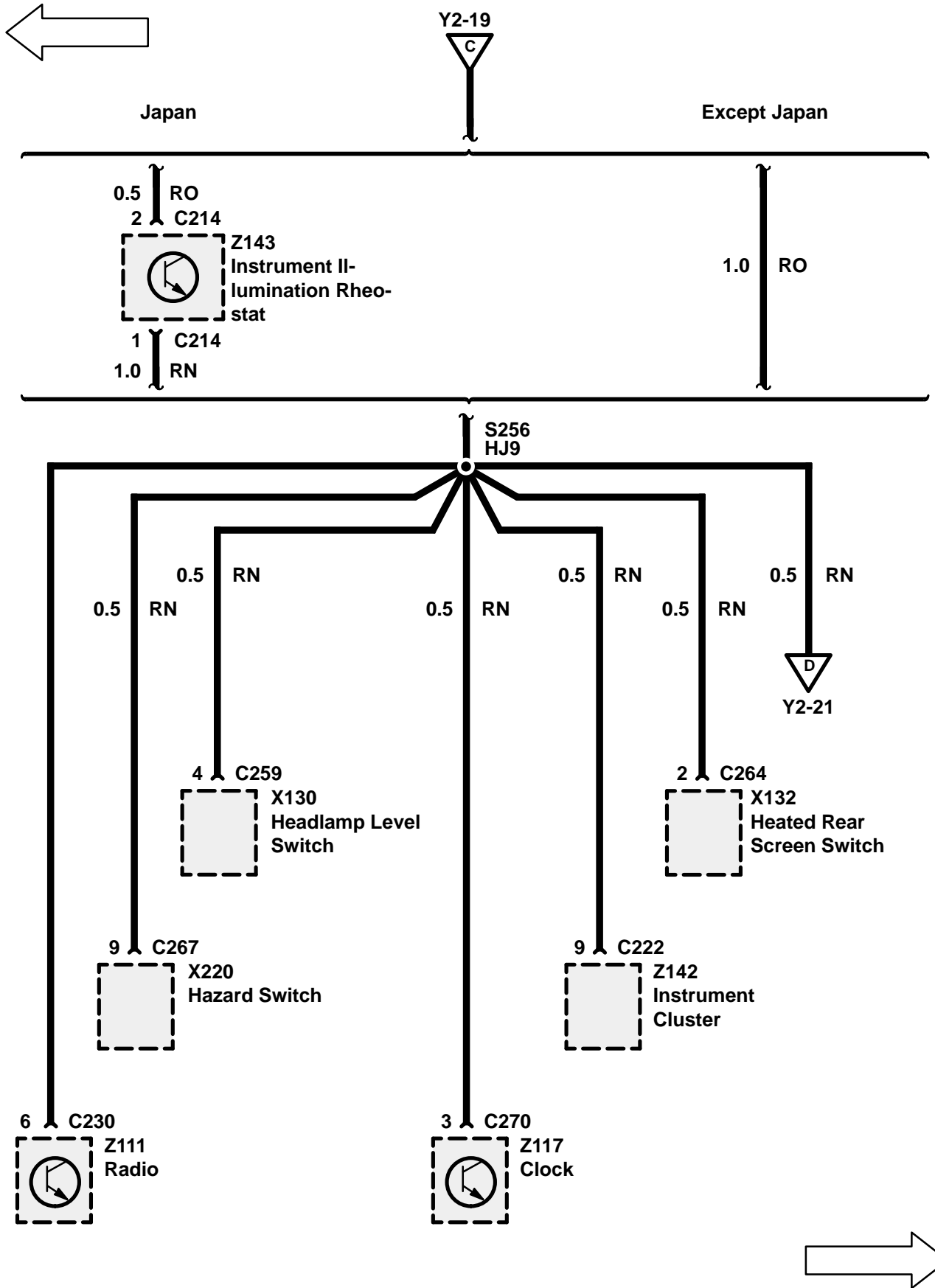



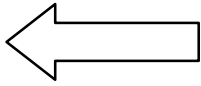

Low Line Radio

Mid Line Radio

High Line Radio

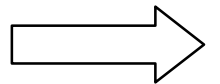
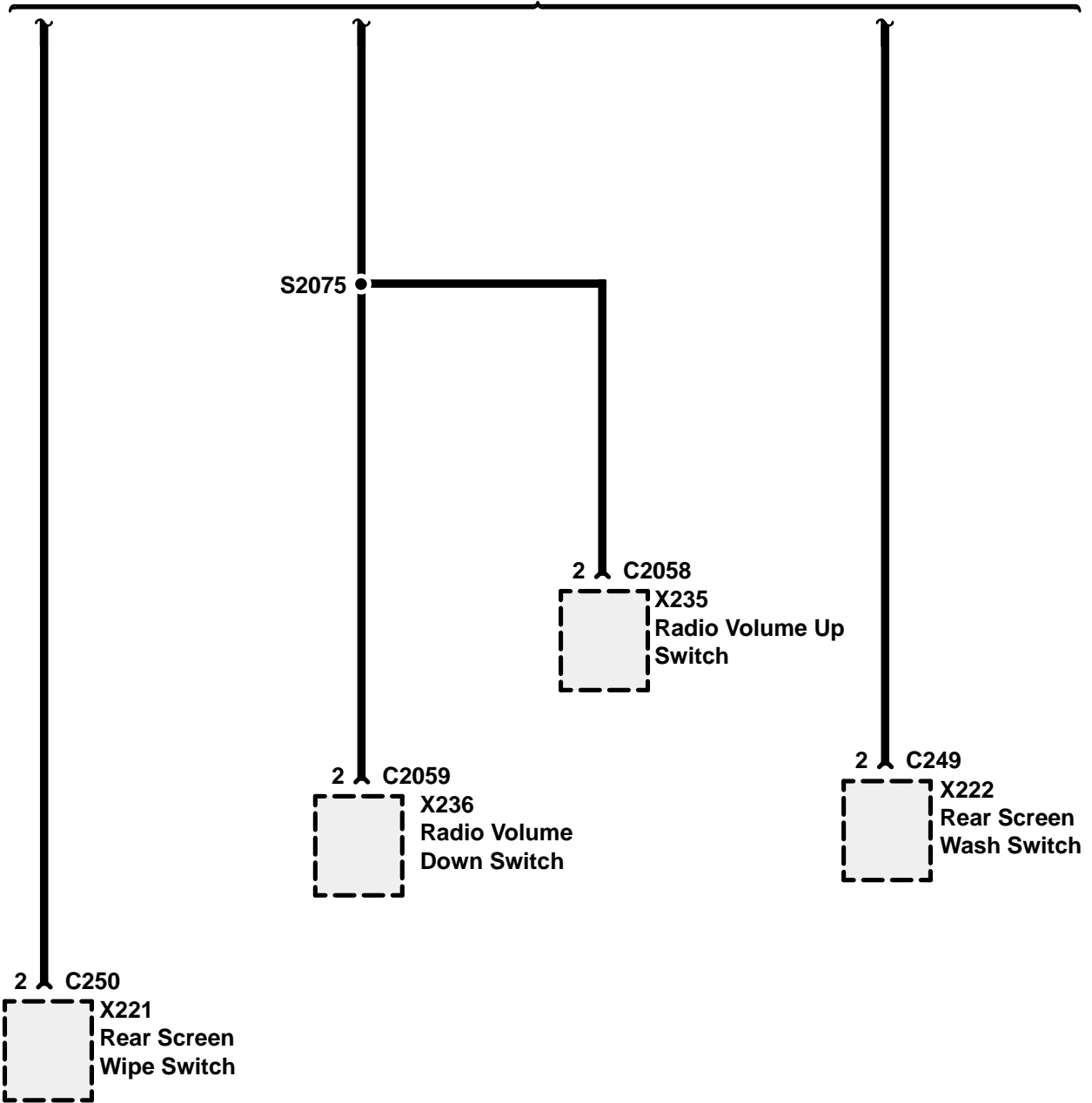

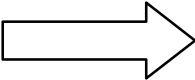
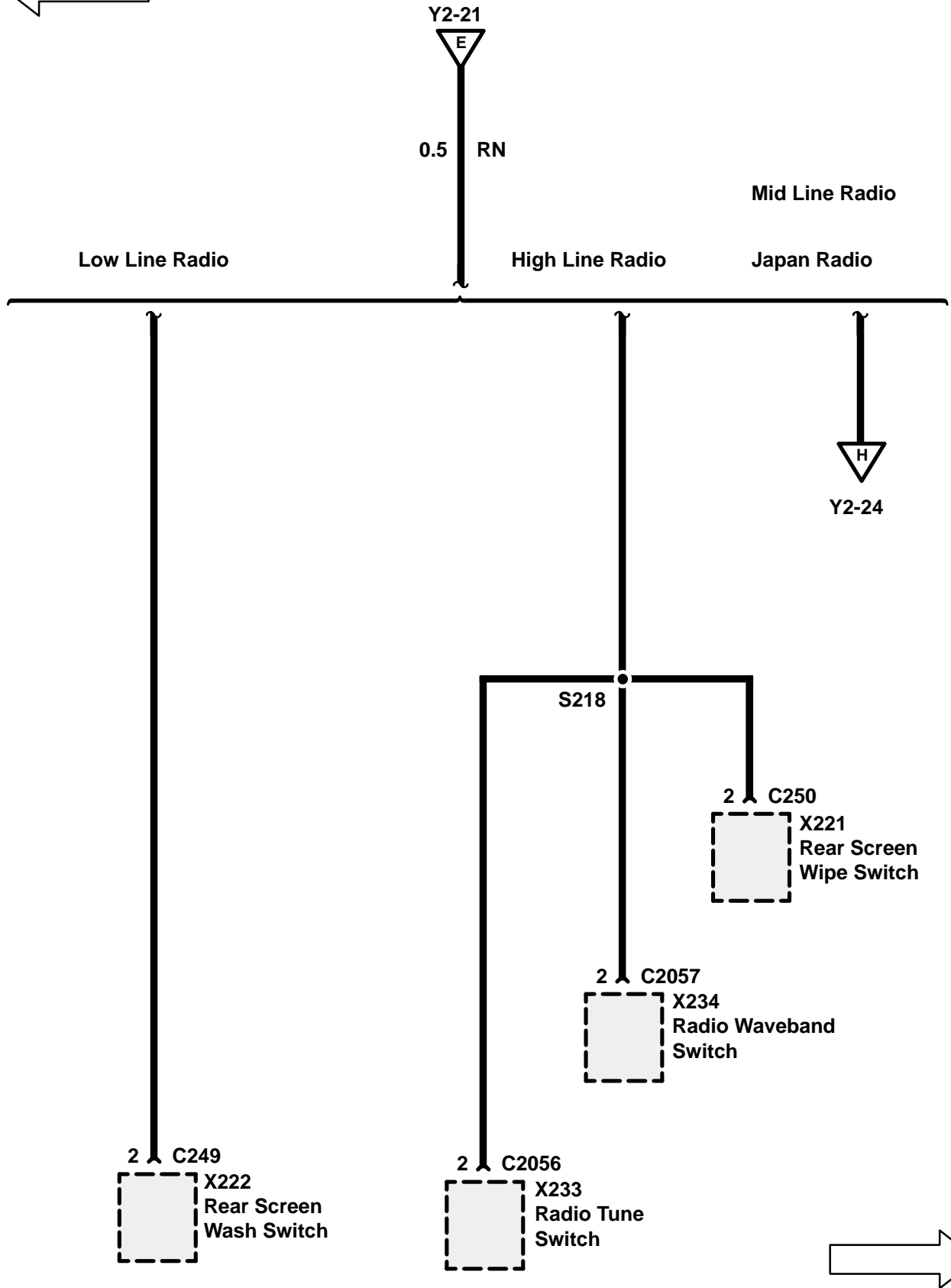
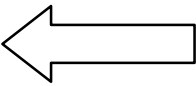



# Y2 ETM

## DISCOVERY

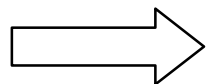
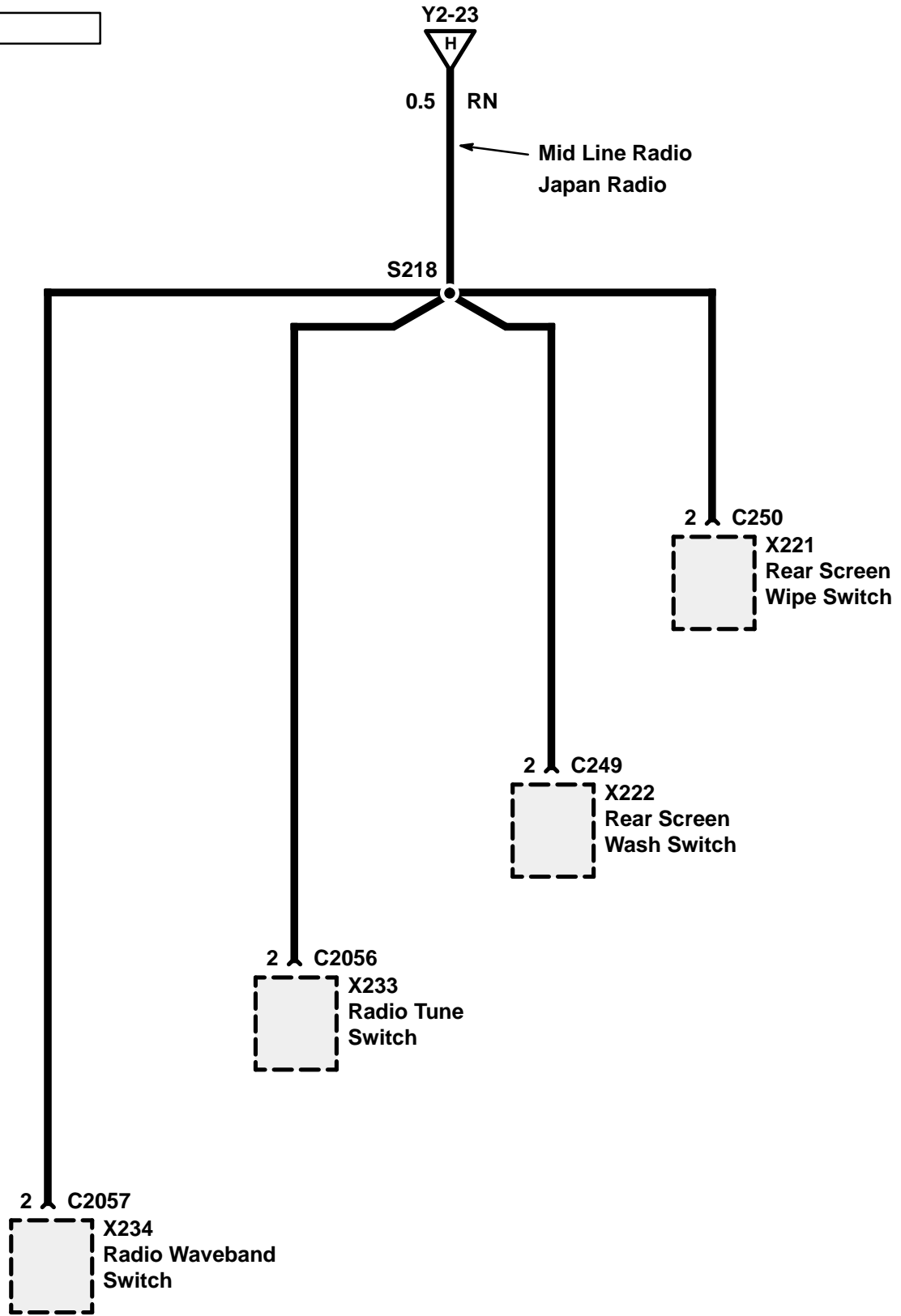
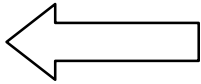

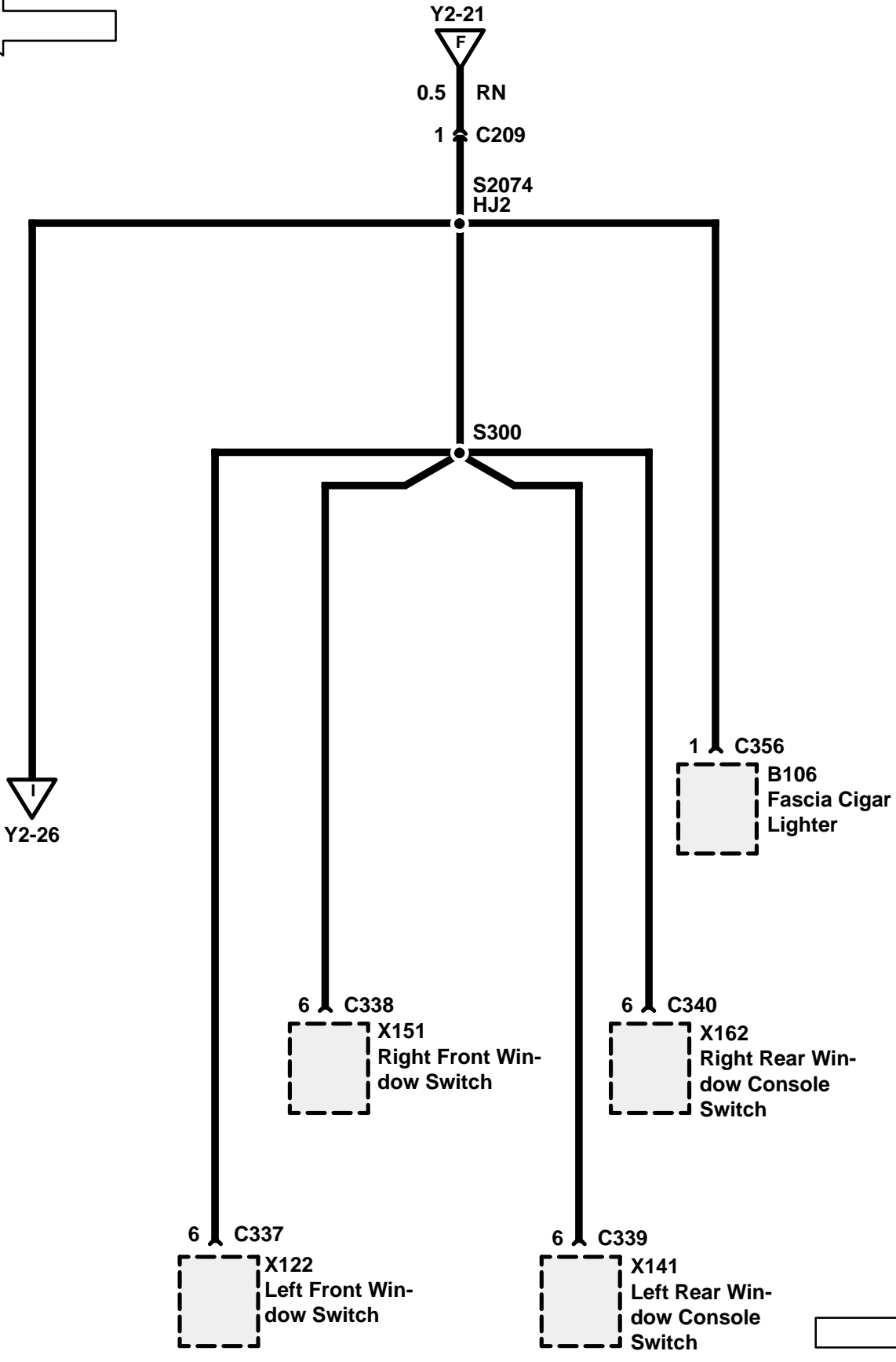
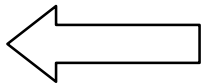

Y2-26

C356  
B106  
Fascia Cigar  
Lighter

C338  
X151  
Right Front Win-  
dow Switch

C340  
X162  
Right Rear Win-  
dow Console  
Switch

C337  
X122  
Left Front Win-  
dow Switch

C339  
X141  
Left Rear Win-  
dow Console  
Switch

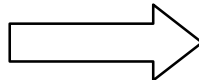

# Y2 ETM

## DISCOVERY

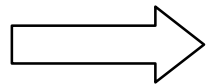
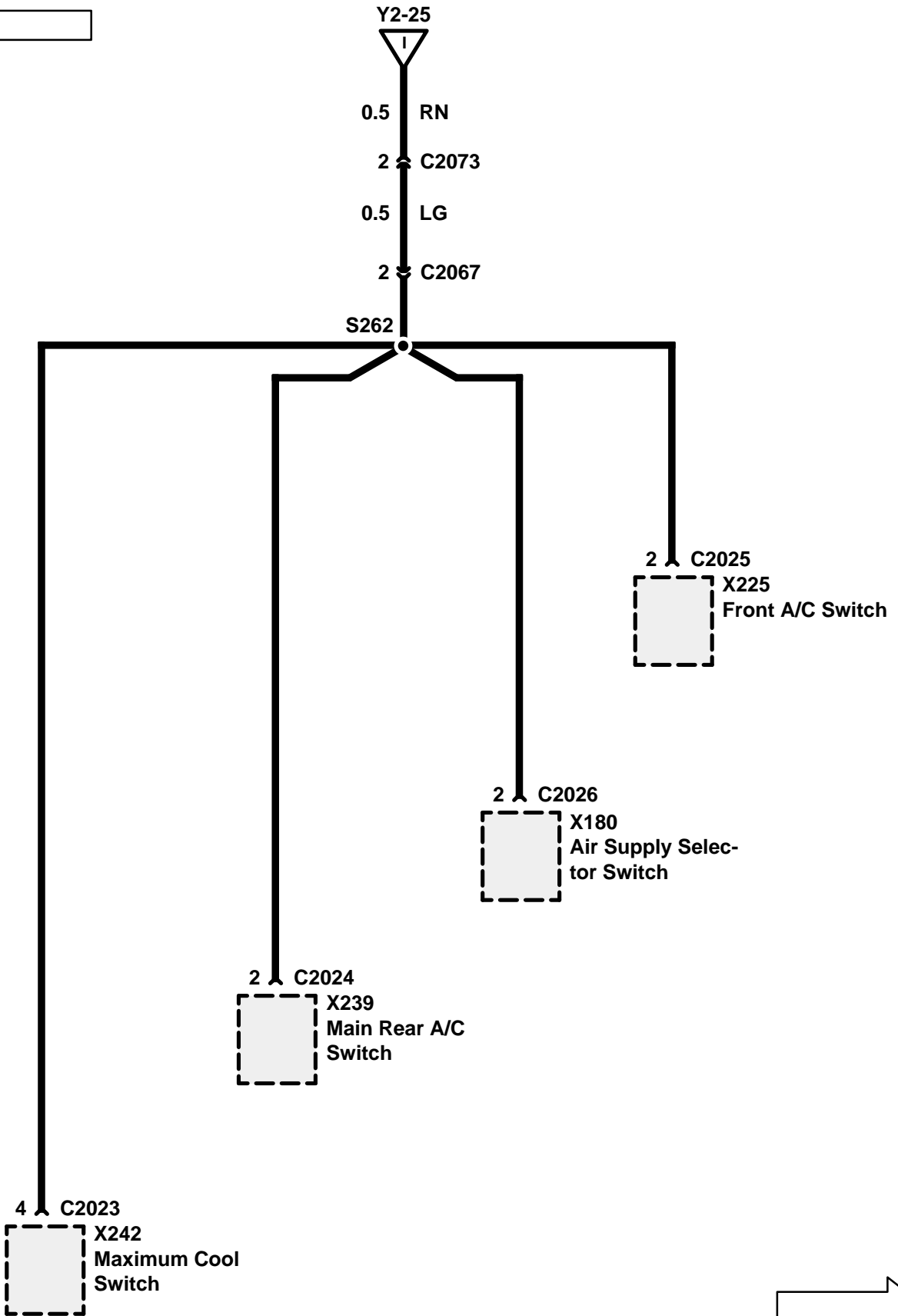
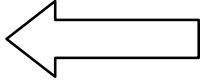

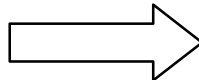
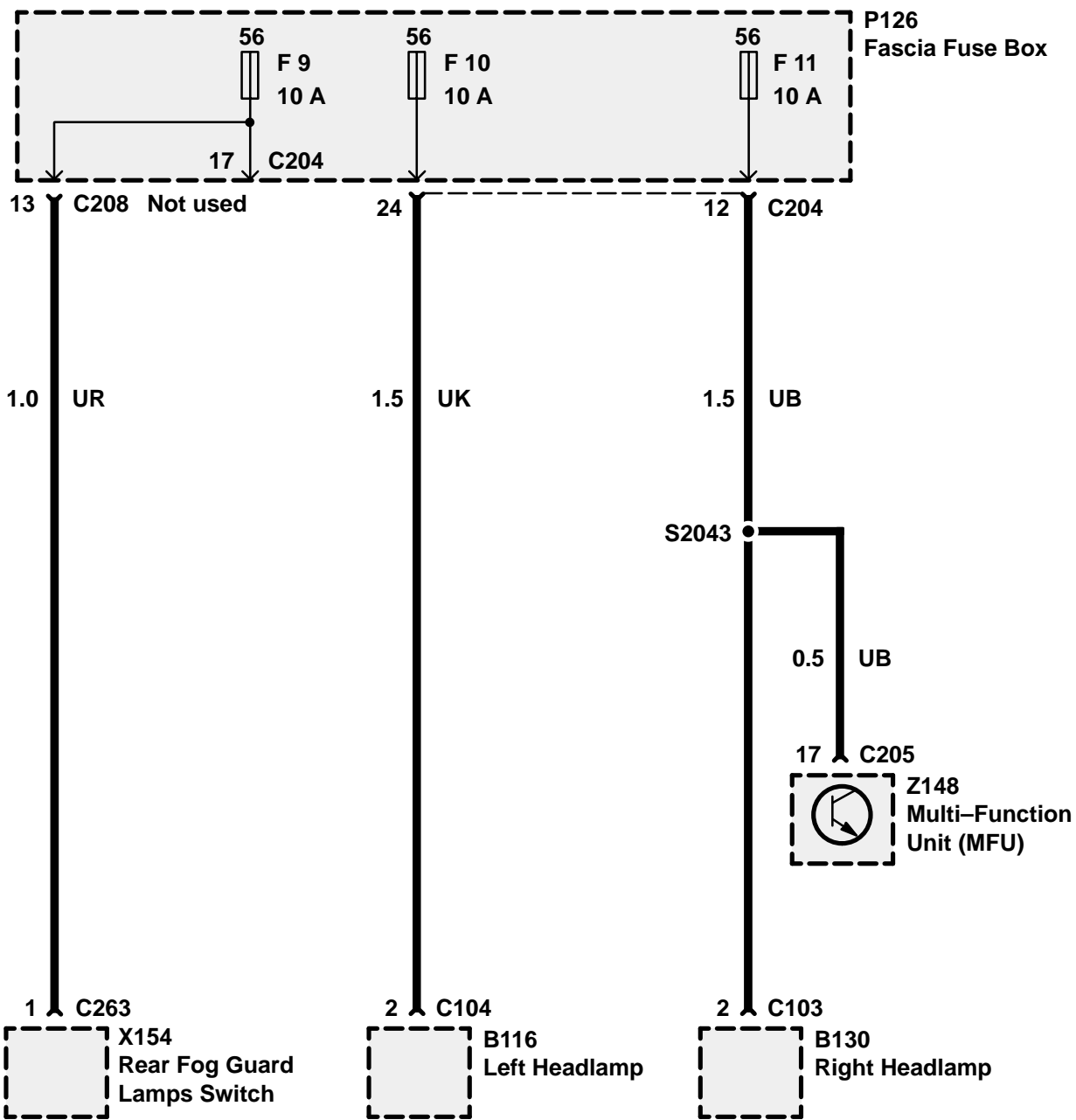
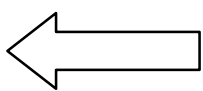

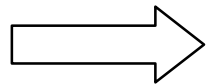
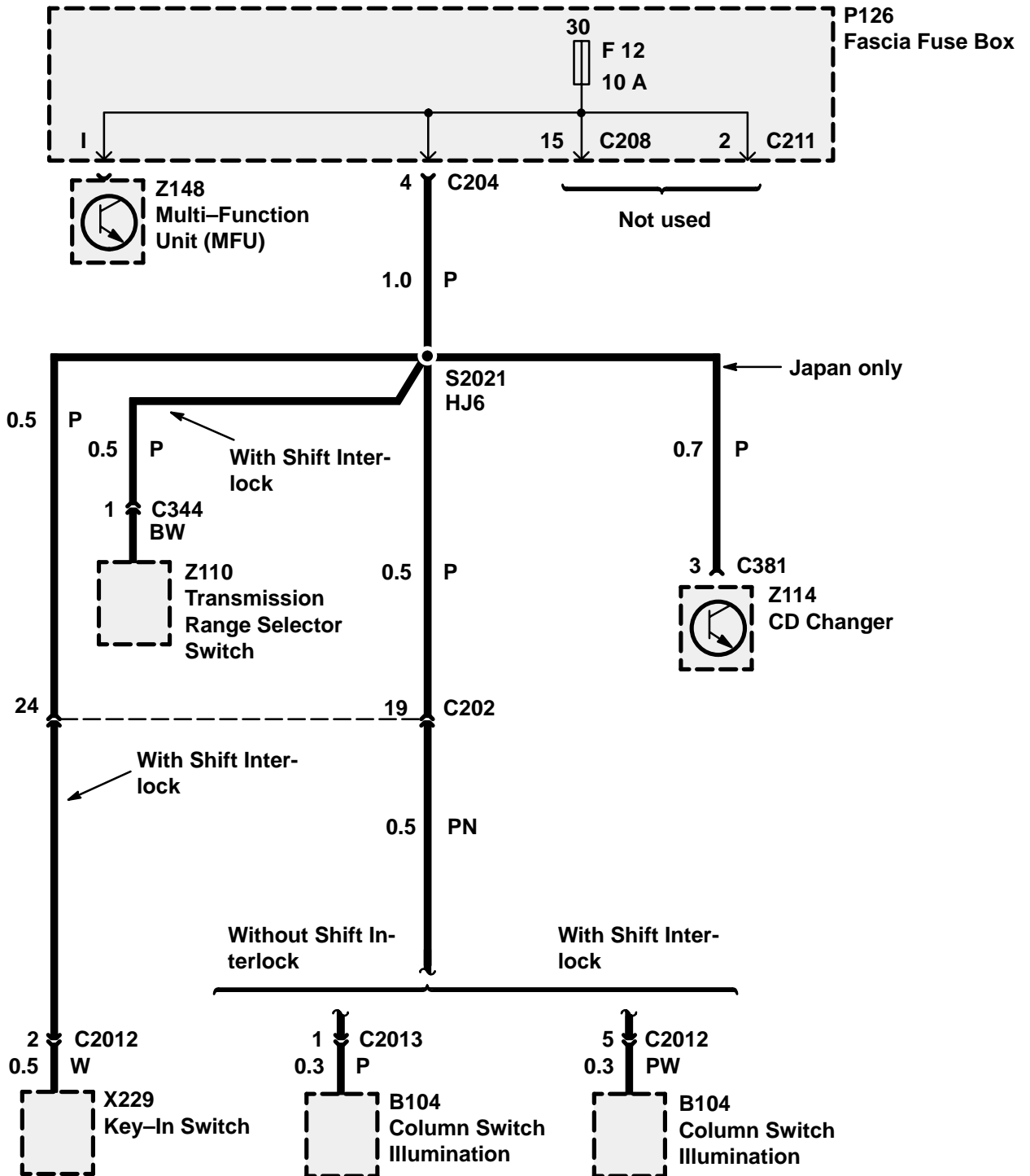
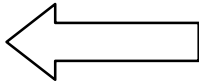

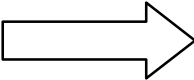
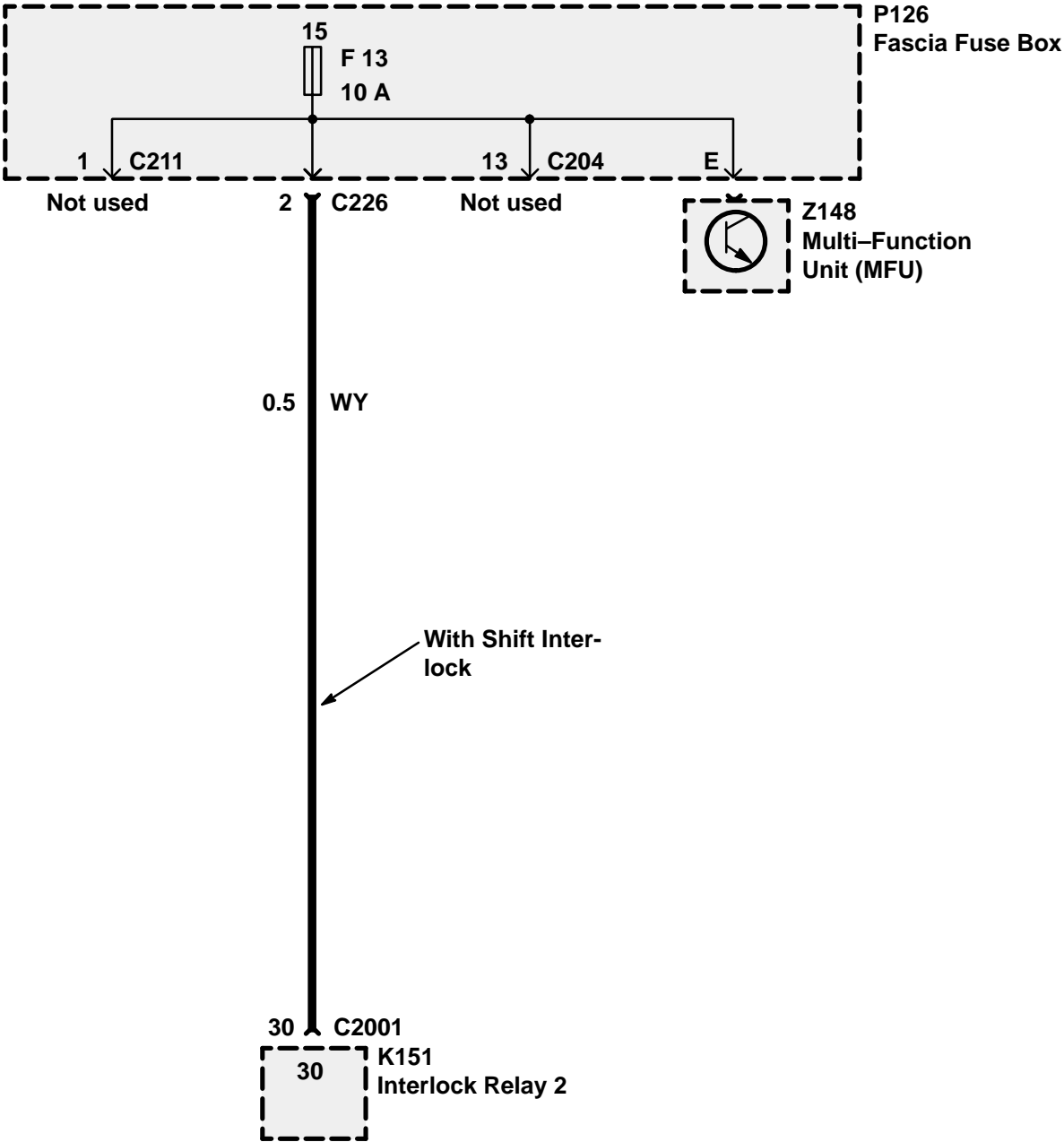
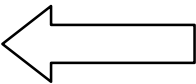

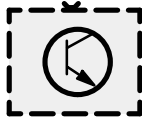
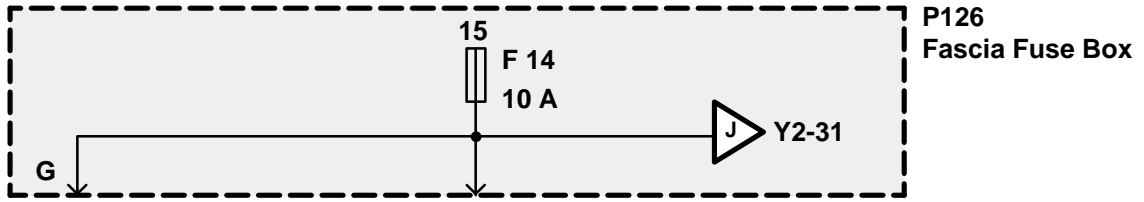
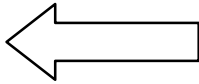

Manual Trans-  
mission

Automatic Trans-  
mission

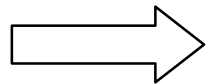
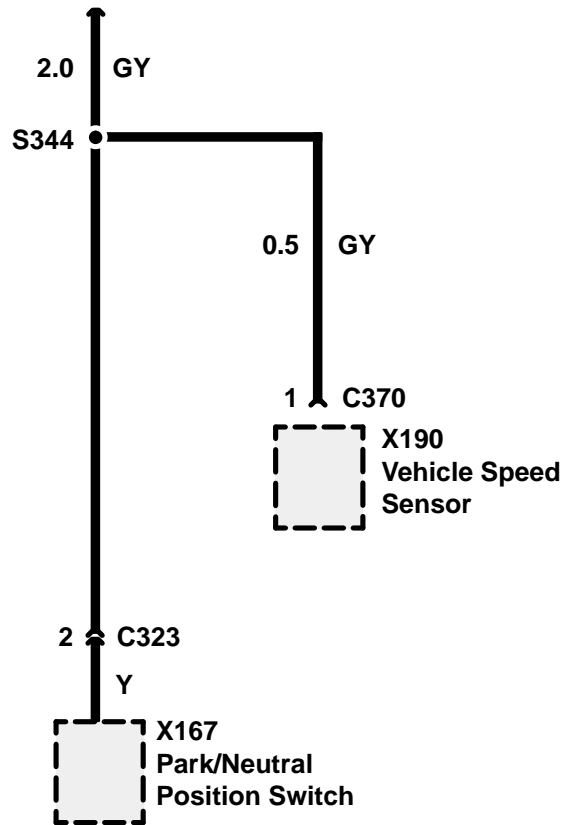
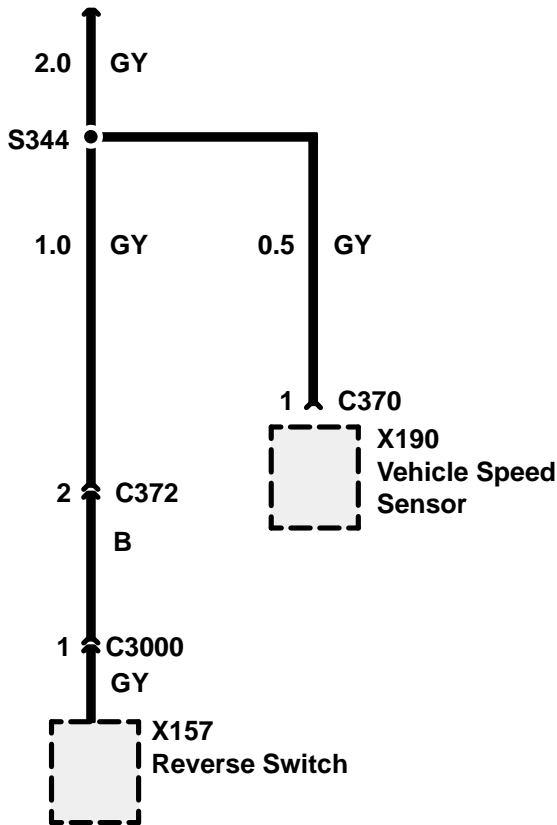

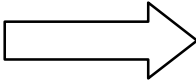
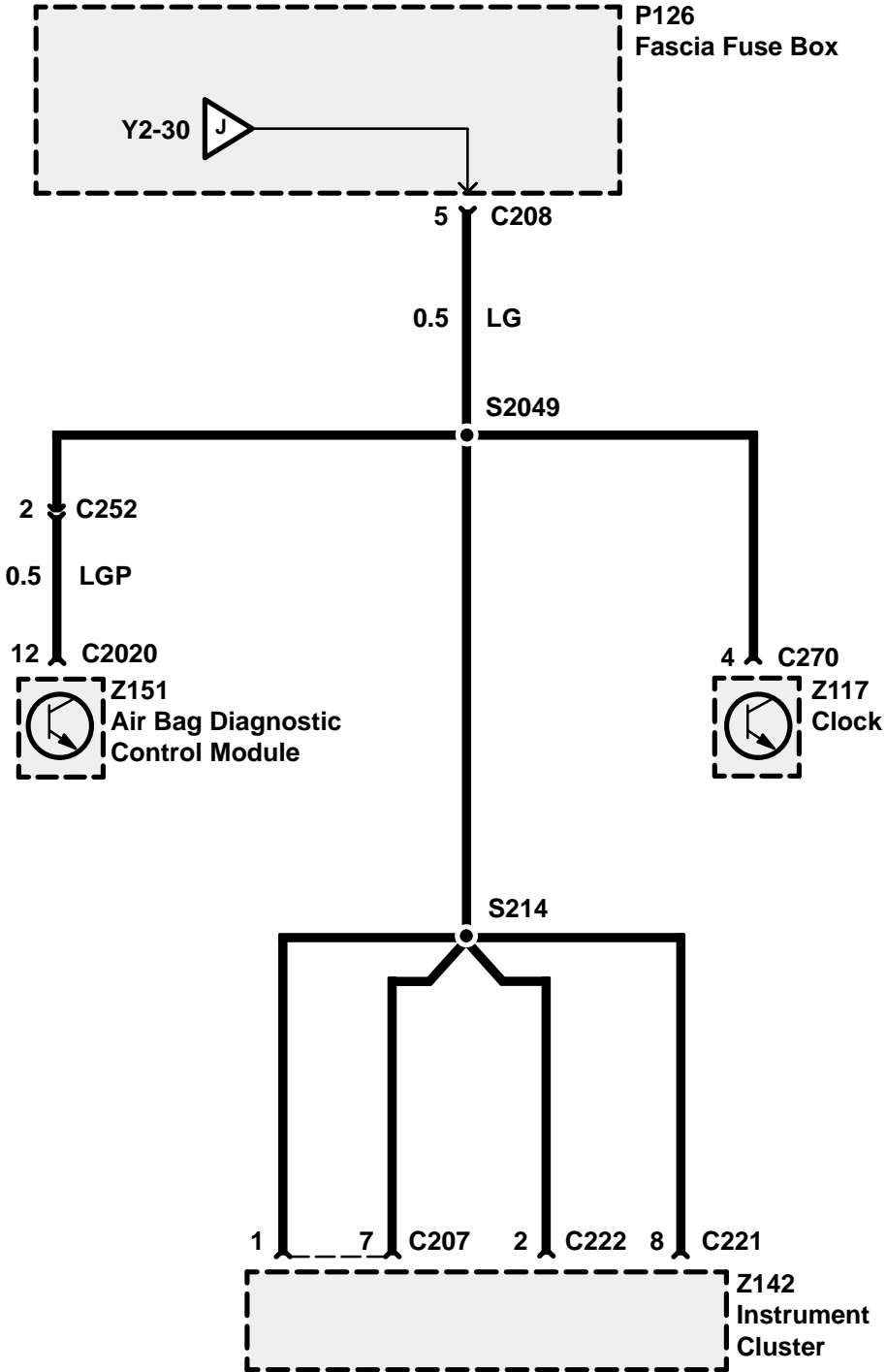
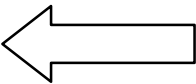





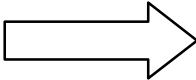
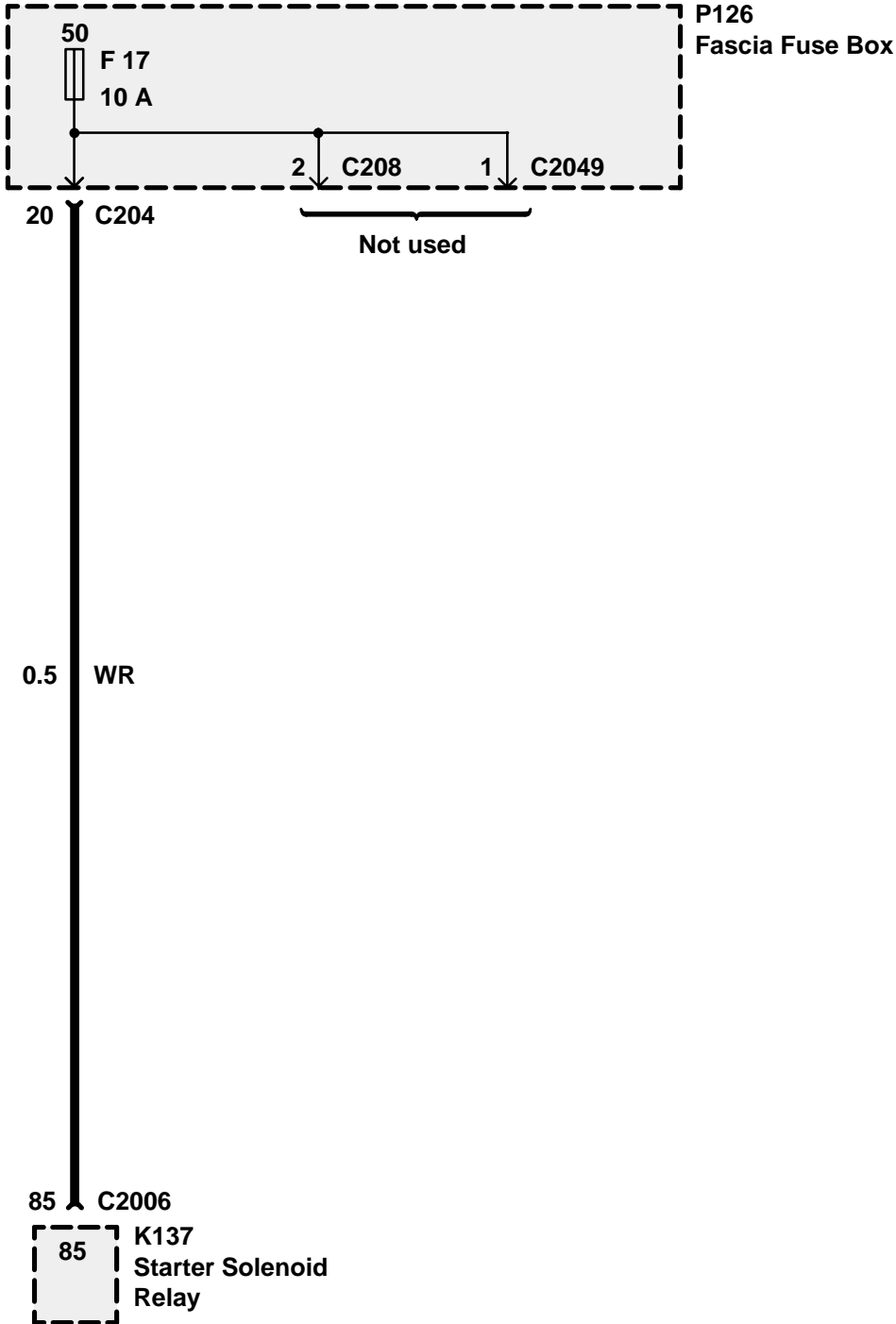
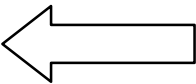

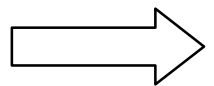
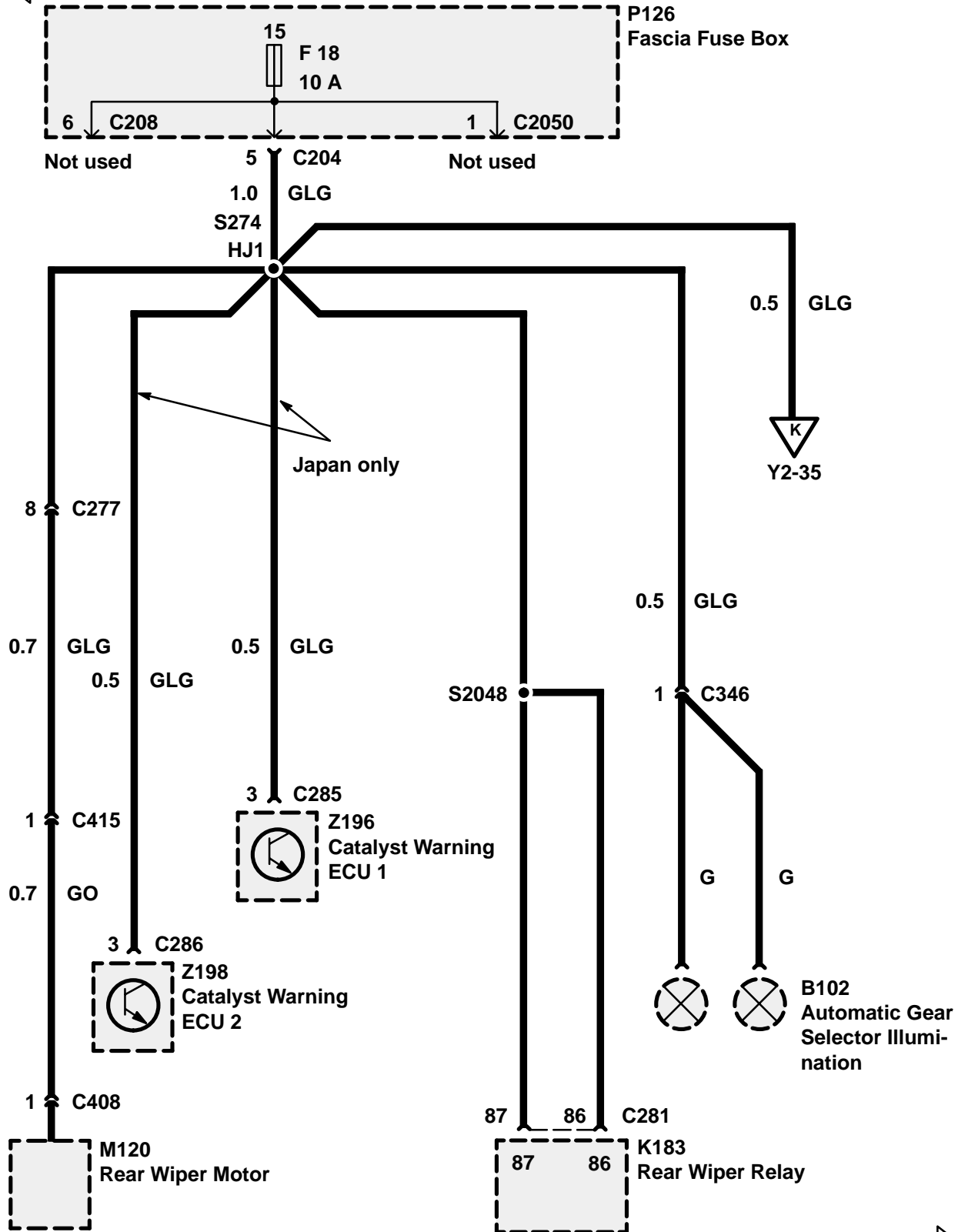
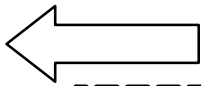

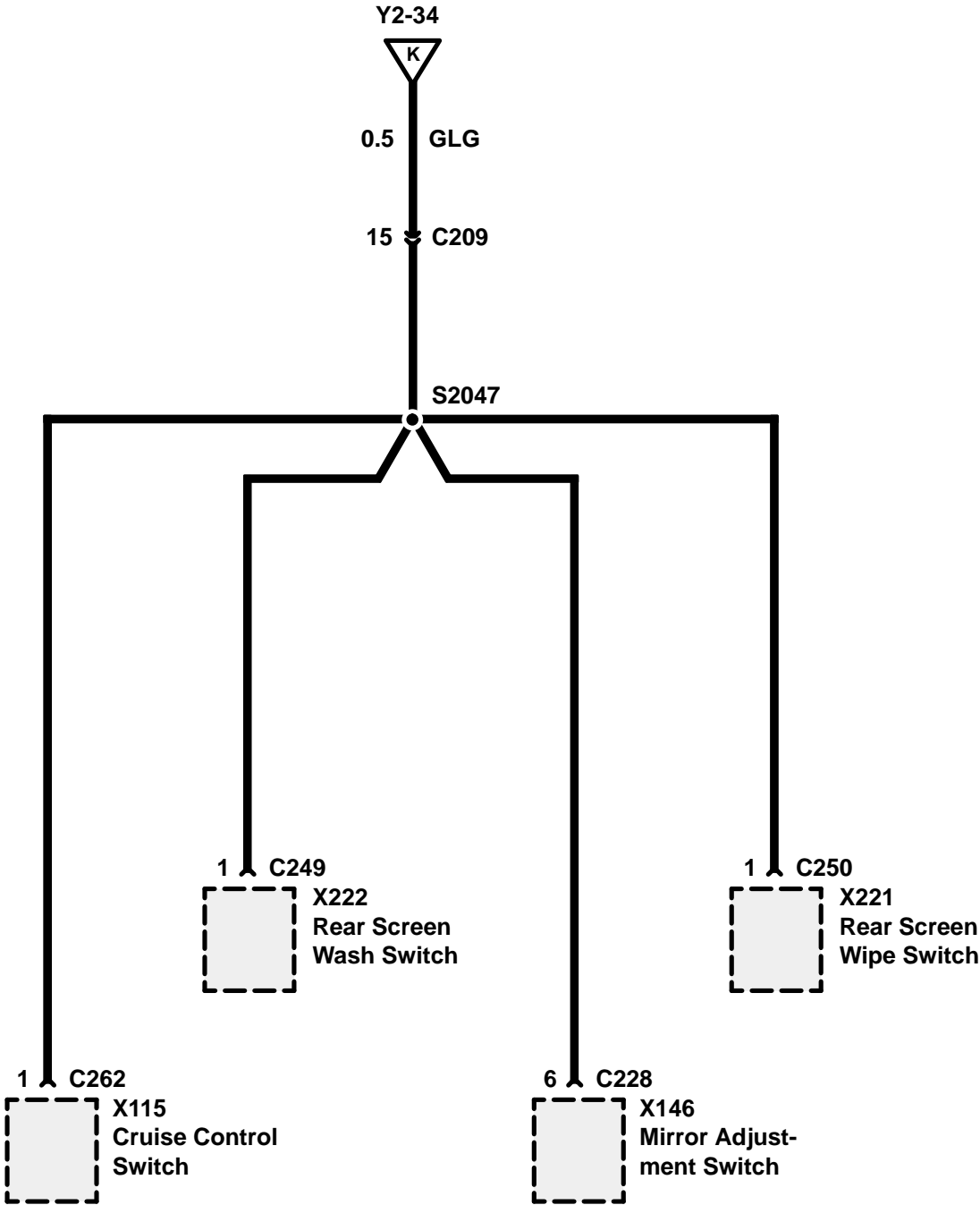
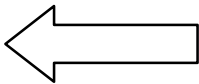

## GROUND AND SPLICE INDEX

Ground	Page	Splice	Page
E100	Y5-2, 3	S112	Y5-6, 8
E101	Y5-4	S122	Y5-13
E103 MFI-V8	Y5-5	S132	Y5-35
E103 MFI-T16	Y5-6, 7	S203/HJ3	Y5-15
E103 300Tdi without EDC	Y5-8	S204/HJ3	Y5-15
E103 300Tdi with EDC	Y5-9, 10	S207	Y5-23
E104	Y5-11	S216	Y5-22
E105	Y5-11	S217	Y5-21
E106	Y5-11	S238/HJ5	Y5-17
E107	Y5-5	S244	Y5-19
E108	Y5-11	S248	Y5-31
E109	Y5-2	S253/HJ8	Y5-22
E110	Y5-11	S255/HJ8	Y5-23
E200	Y5-12, 13, 14, 15, 16, 17, 18, 19, 20, 21, 22	S266	Y5-13
E201	Y5-21, 22, 23, 24, 25, 26, 27, 28, 29, 30, 31, 32, 33, 34	S268	Y5-9
E203	Y5-35	S272	Y5-33, 34
E204	Y5-35	S277	Y5-21
E303	Y5-36	S288/HJ11	Y5-27
E400	Y5-37, 38, 39	S289	Y5-5
E401	Y5-40, 41	S290/HJ7	Y5-3
E404	Y5-38	S294	Y5-3
		S2003/HJ10	Y5-19
		S2015/HJ10	Y5-20
		S2016/HJ10	Y5-18
		S2023/HJ11	Y5-30
		S2024	Y5-32
		S2025/HJ5	Y5-16
		S2031/HJ5	Y5-16
		S2032/HJ3	Y5-15
		S2044/HJ11	Y5-27
		S2050	Y5-12
		S2051	Y5-35
		S307	Y5-12
		S343	Y5-25, 26
		S401	Y5-39
		S402	Y5-41
		S415	Y5-38
		S417	Y5-37
		S418	Y5-40
		S422	Y5-37
		S423	Y5-39
		S424	Y5-41
		S426	Y5-37
		S501	Y5-28
		S601	Y5-14

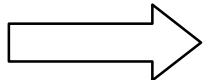
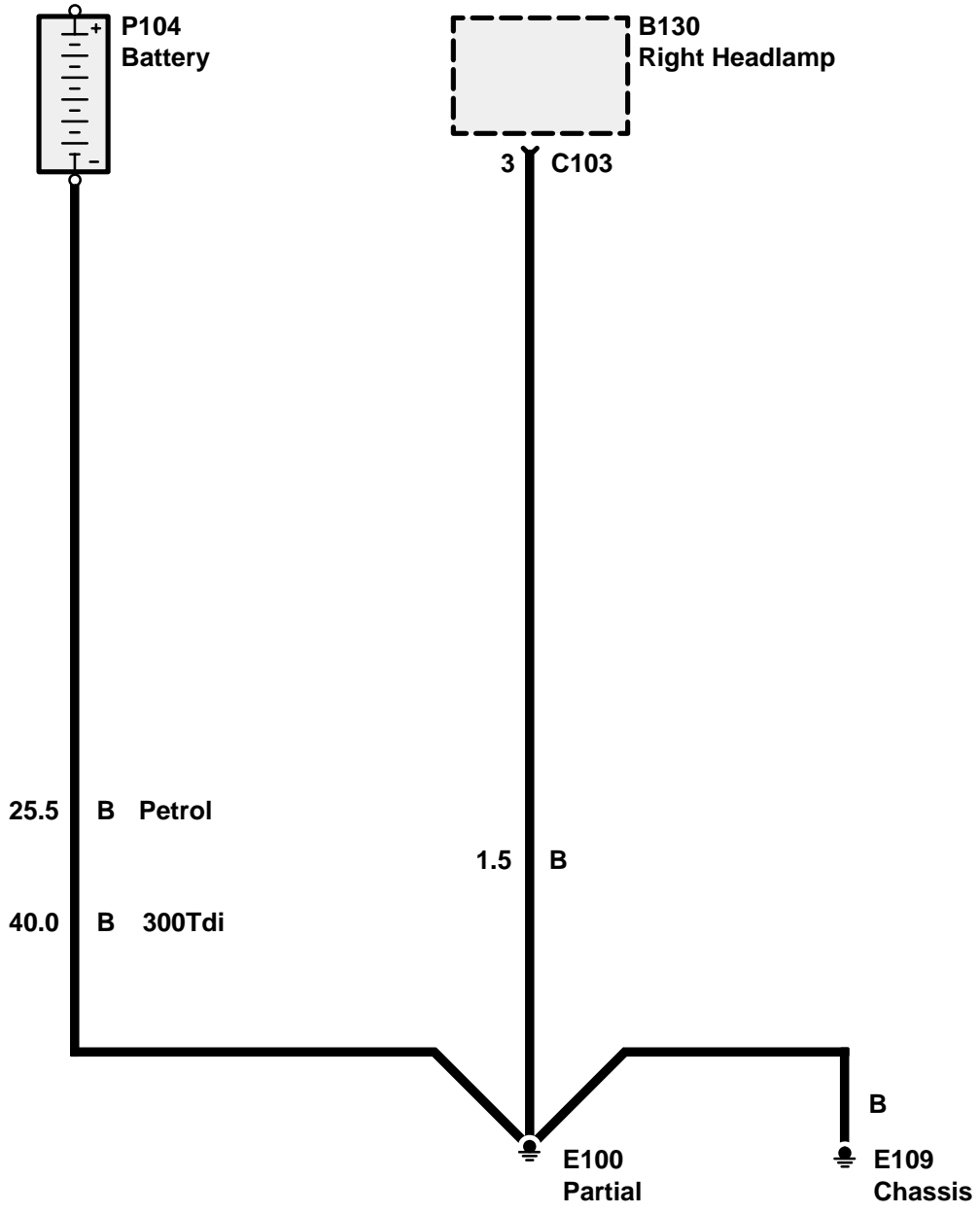

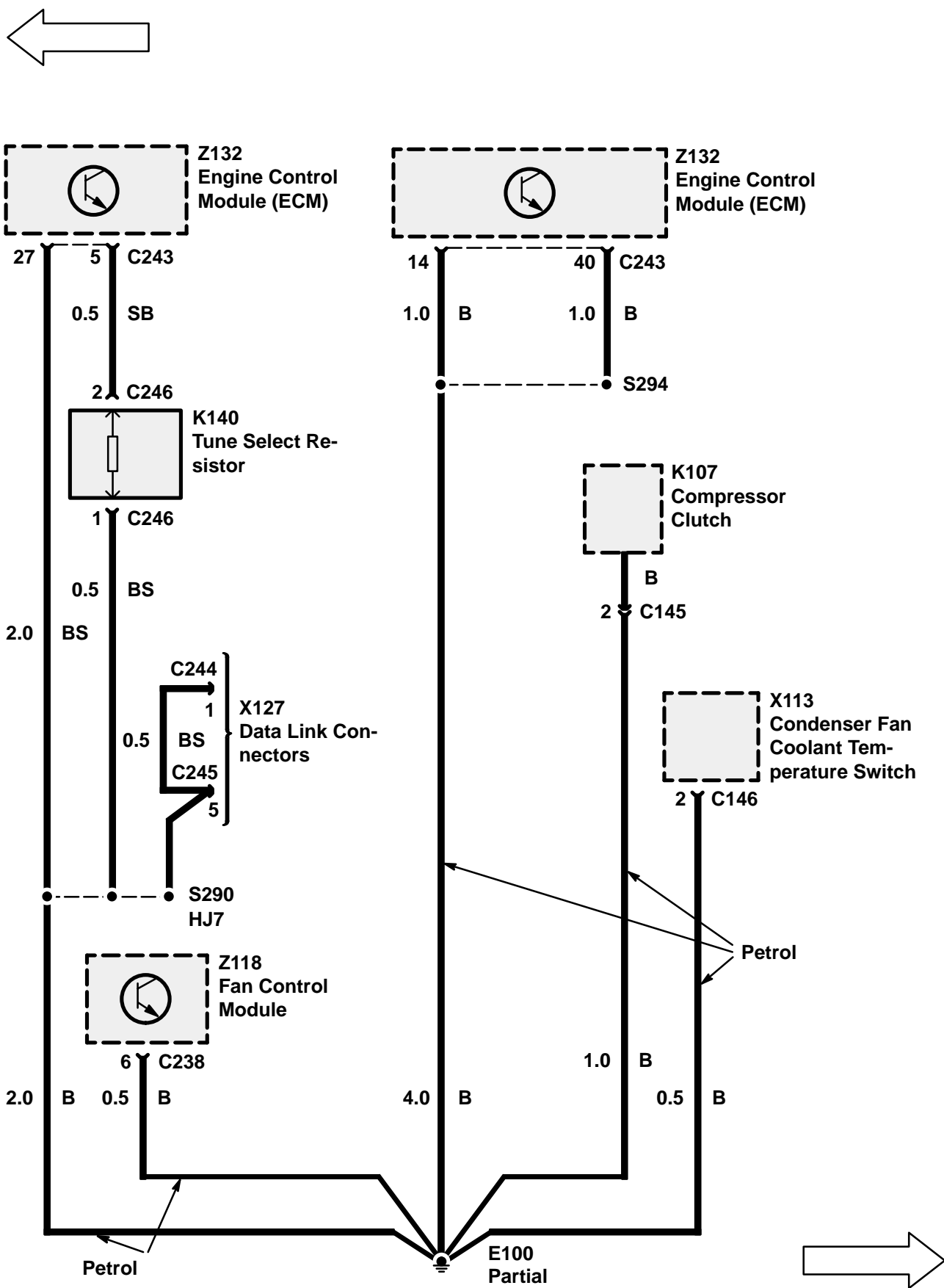

**Y5 ETM**

Ground Distribution

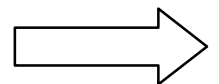
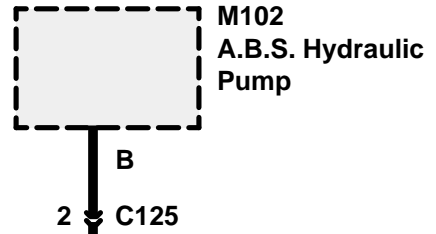
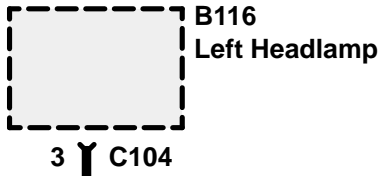
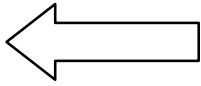



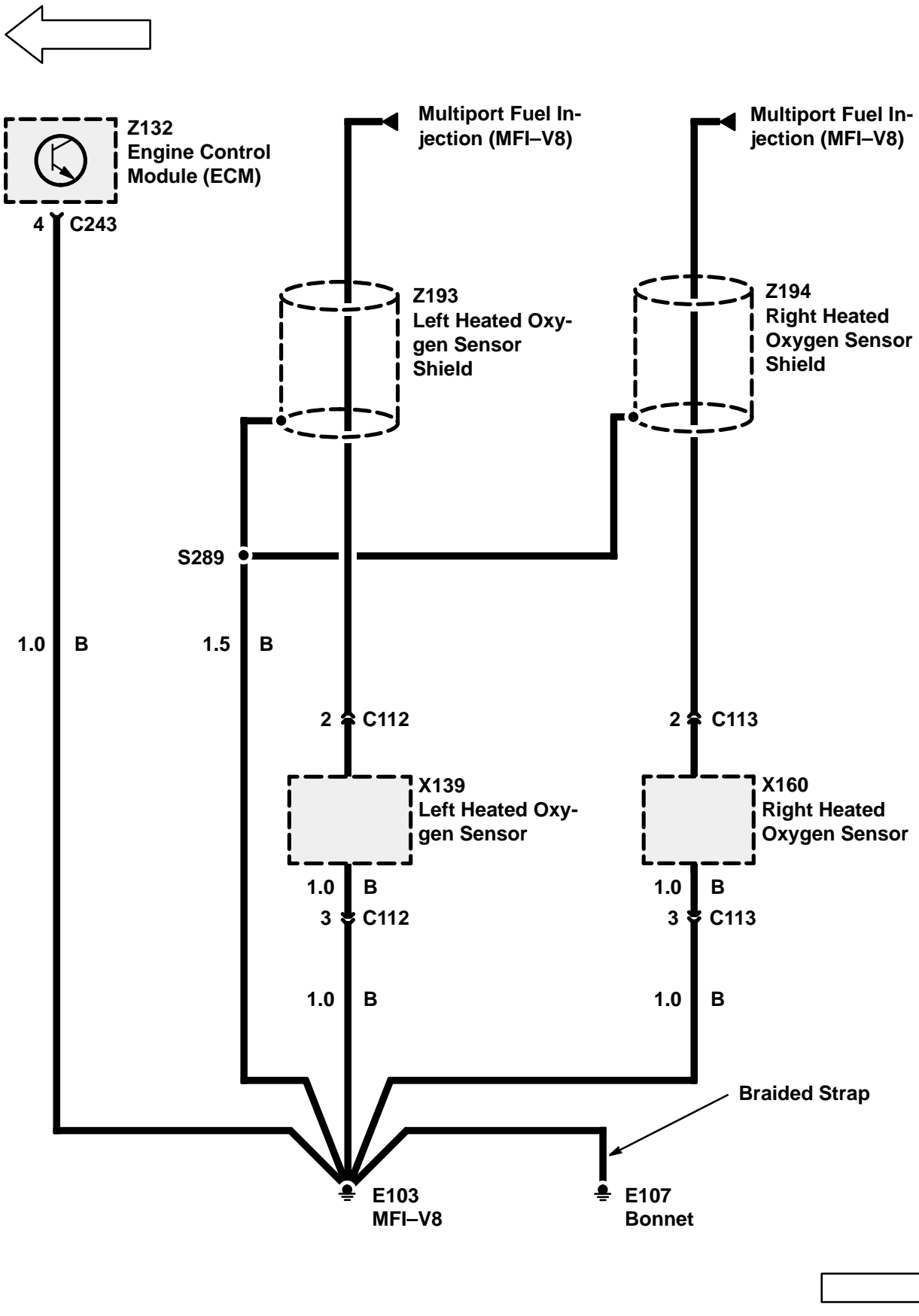

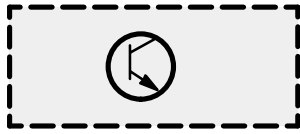
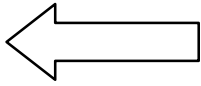

Z132  
Engine Control  
Module (ECM)

29 14 C1007



X139  
Left Heated Oxy-  
gen Sensor

3 C112

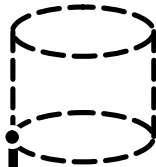

Z193  
Left Heated Oxy-  
gen Sensor  
Shield

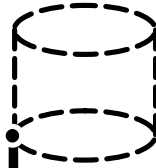

Z201  
Knock Sensor  
Shield

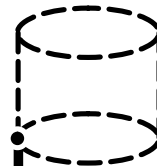

Z202  
Crankshaft Posi-  
tion Sensor  
Shield

1.5 B 0.5 B 0.7 B

S112

1.5 B



Y5-7

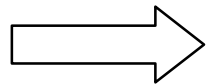

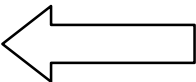

K170  
A/C Logic Relay

87

87 C242



M142  
Cooling Fan  
Motor 2

B

2 C1012



K107  
Compressor  
Clutch

B

2 C145



M141  
Cooling Fan  
Motor 1

B

2 C1011

Y5-6



0.5

B

1.0

B

1.5

B

1.5

B

3.0

B



E103  
MFI-T16

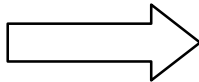

# Y5 ETM

## DISCOVERY

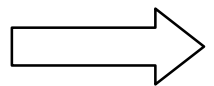
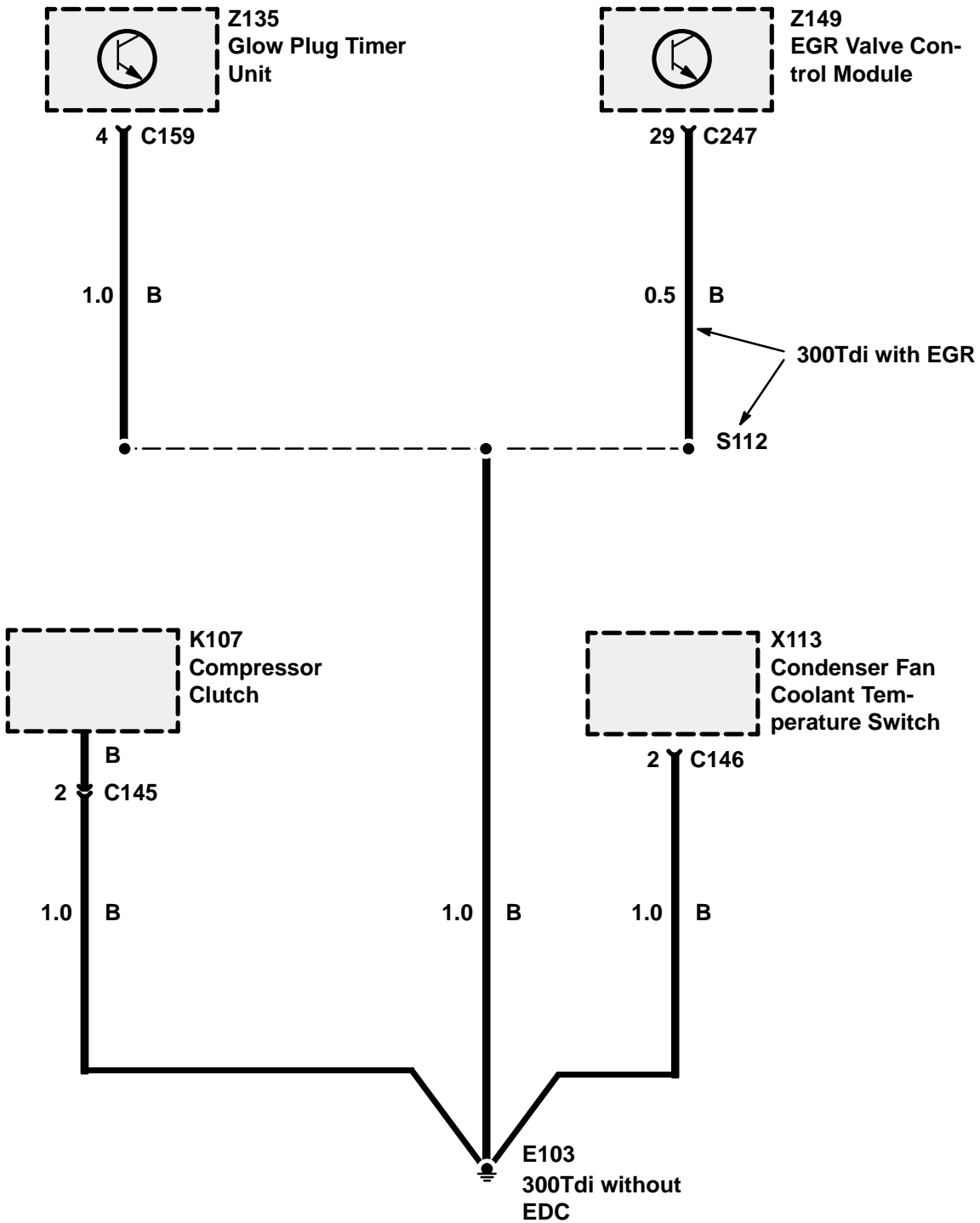
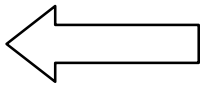

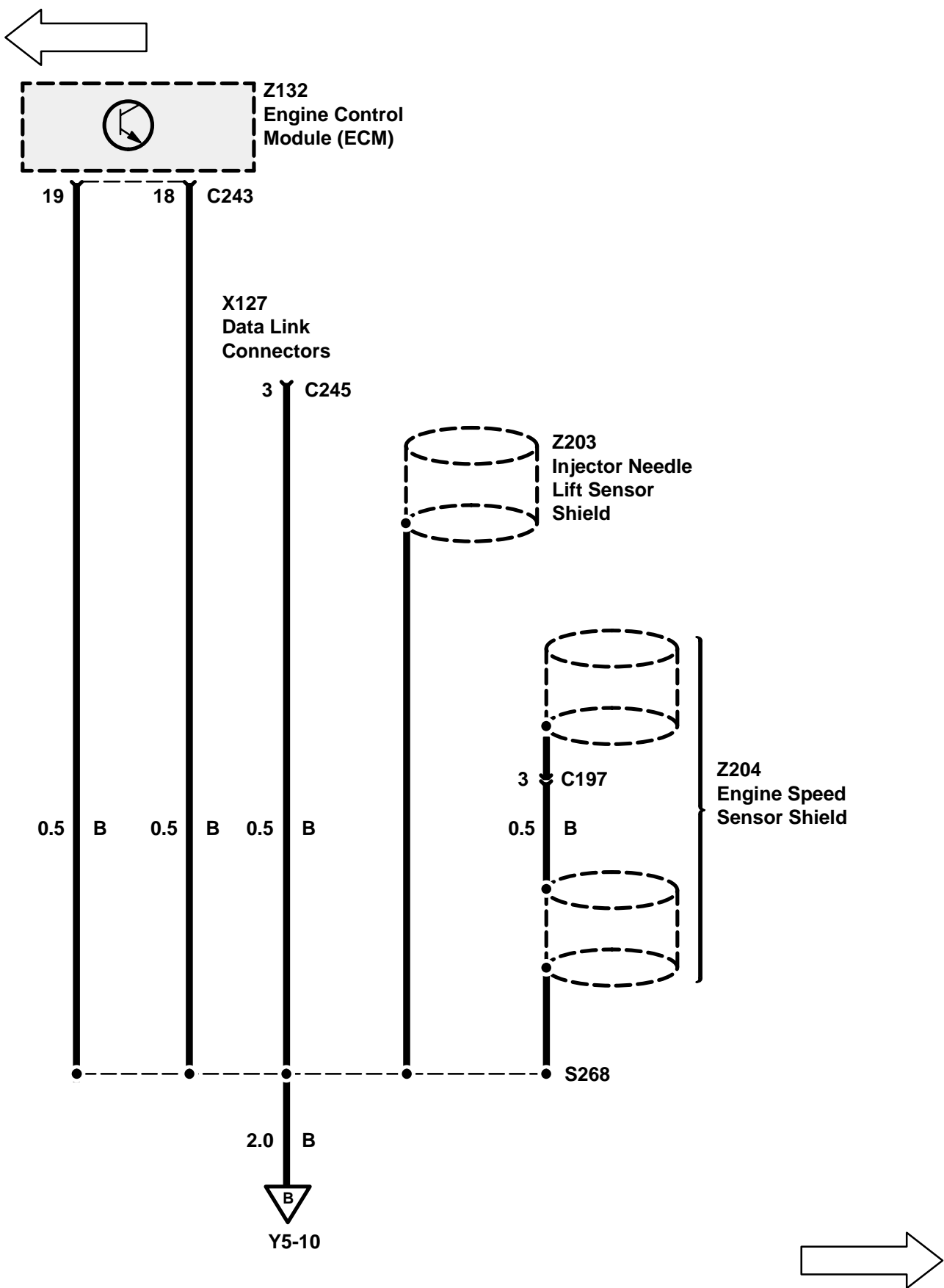

# Y5 ETM

DISCOVERY

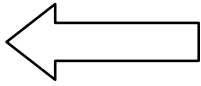

Z135  
Glow Plug Timer  
Unit

4 C159



X113  
Condenser Fan  
Coolant Tem-  
perature Switch

2 C146



K107  
Compressor  
Clutch

B  
2 C145

0.5 B

0.5 B

2.0 B

1.0 B



E103  
300Tdi with EDC

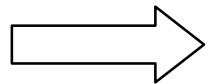

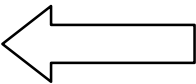

Braided Strap

Braided Strap



E105  
Ignition Coil

E106  
Engine

Braided Strap



E104  
Chassis

E108  
Starter

E110

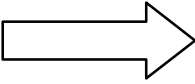

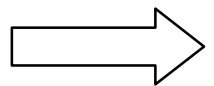
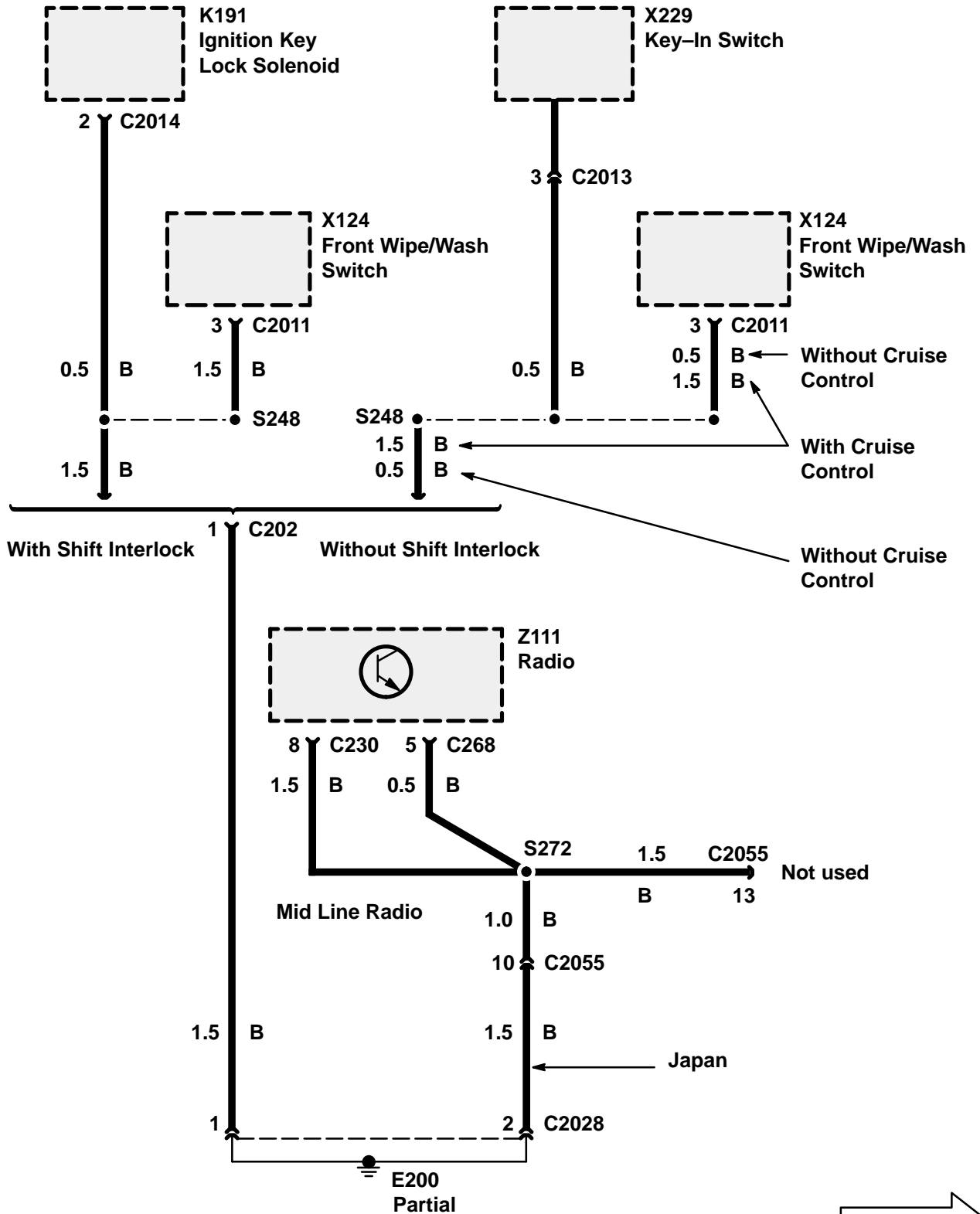
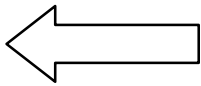



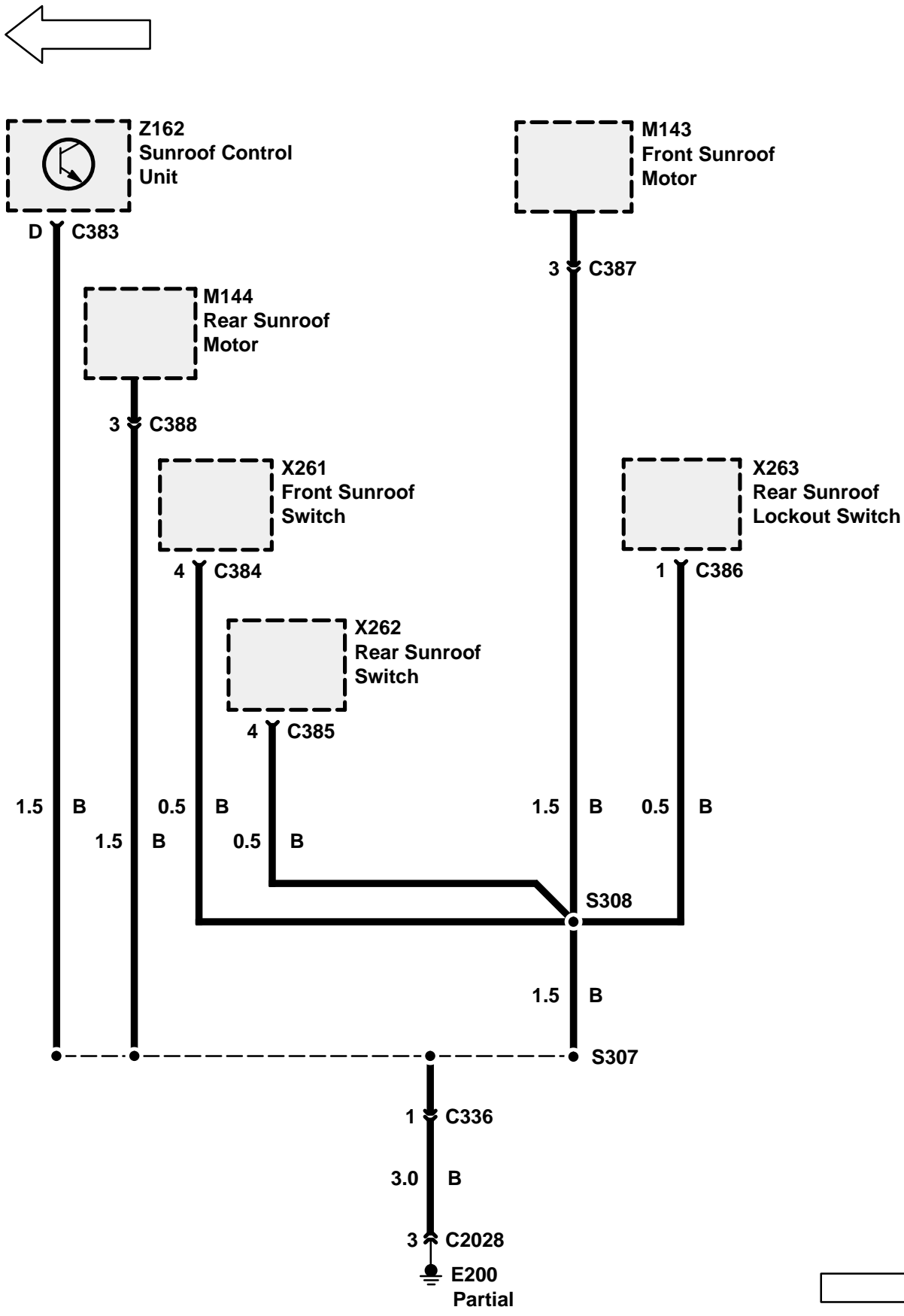

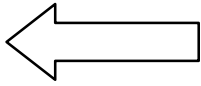

M121  
Right Condenser  
Fan Motor

B  
2 C182



M113  
Left Condenser  
Fan Motor

B  
2 C183

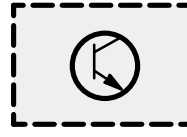

Z176  
Subwoofer  
Amplifier

1 C412

3 C437

7 C212

Z199  
Subwoofer Am-  
plifier Shield

S122

C  
Y5-15

1.5 B

4 C2028

E200  
Partial

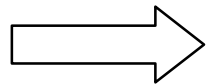

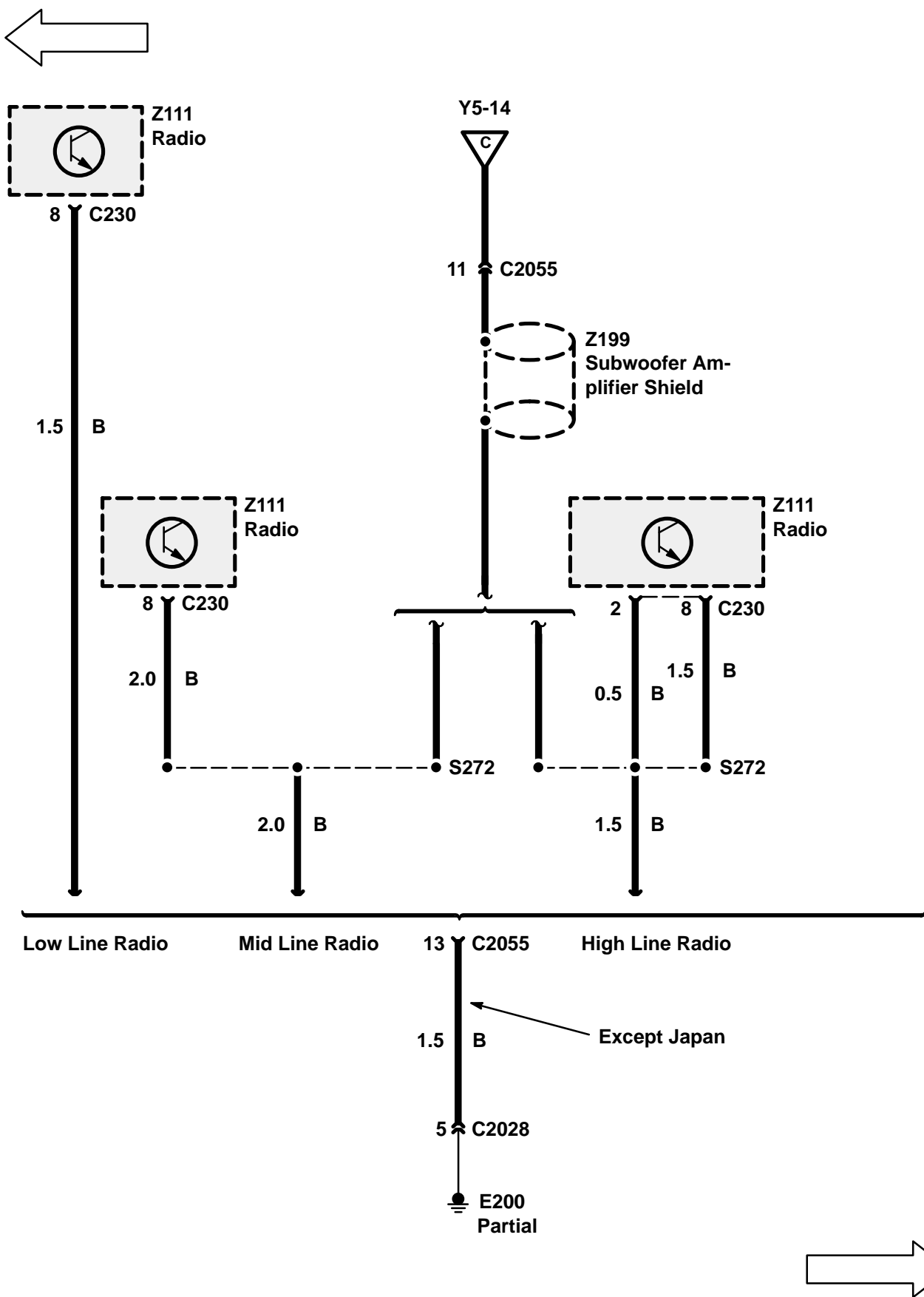

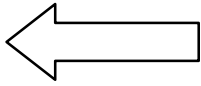

X233  
Radio Tune  
Switch

4 5 C2056



X234  
Radio Waveband  
Switch

4 5 C2057

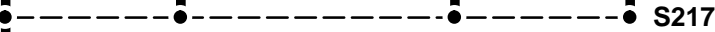

X235  
Radio Volume Up  
Switch

4 5 C2058



X236  
Radio Volume  
Down Switch

4 5 C2059

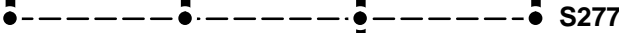

0.5 B



Y5-17

0.5 B



Y5-17

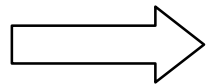

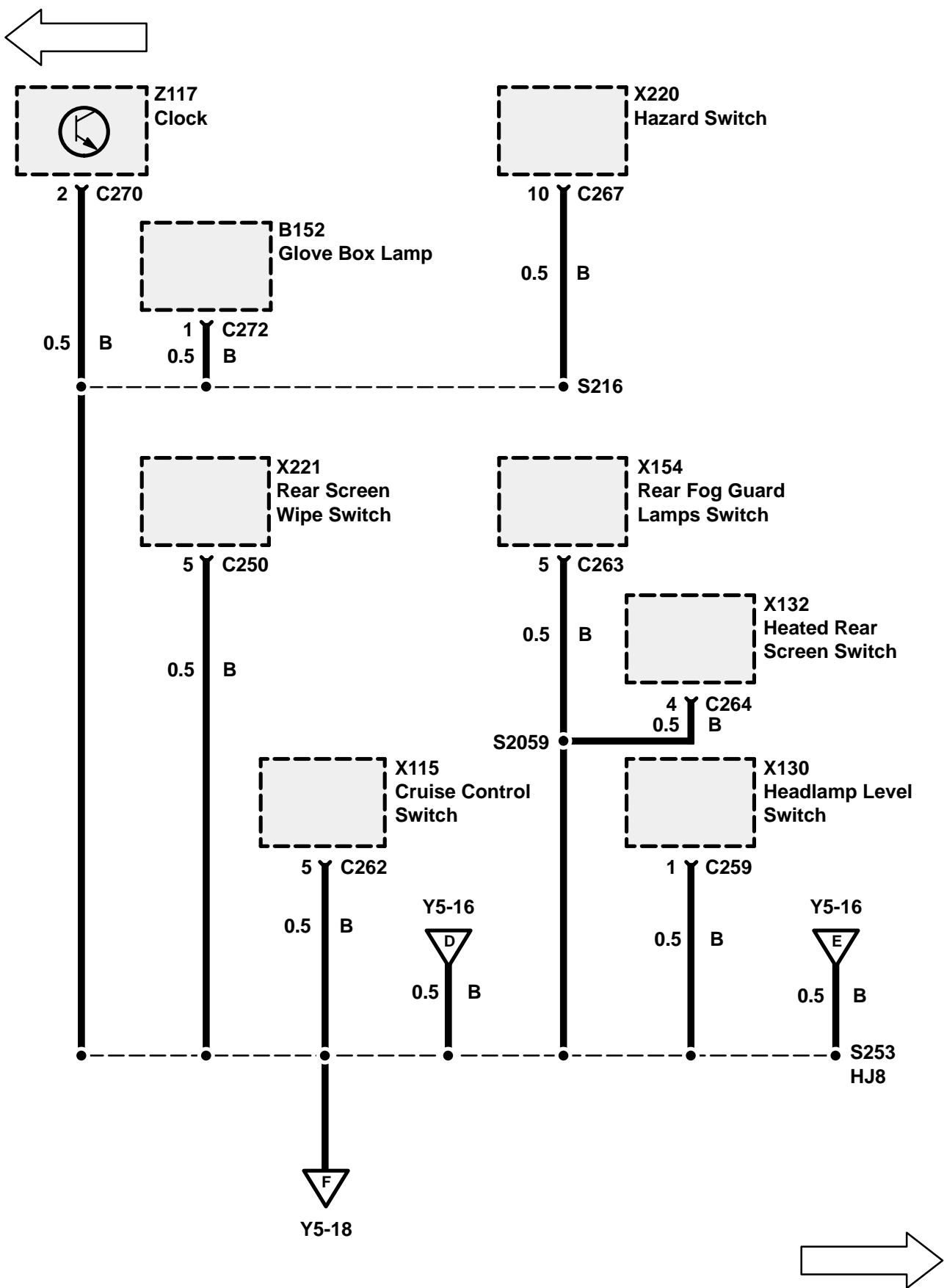

# Y5 ETM

## DISCOVERY

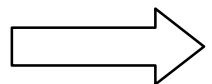
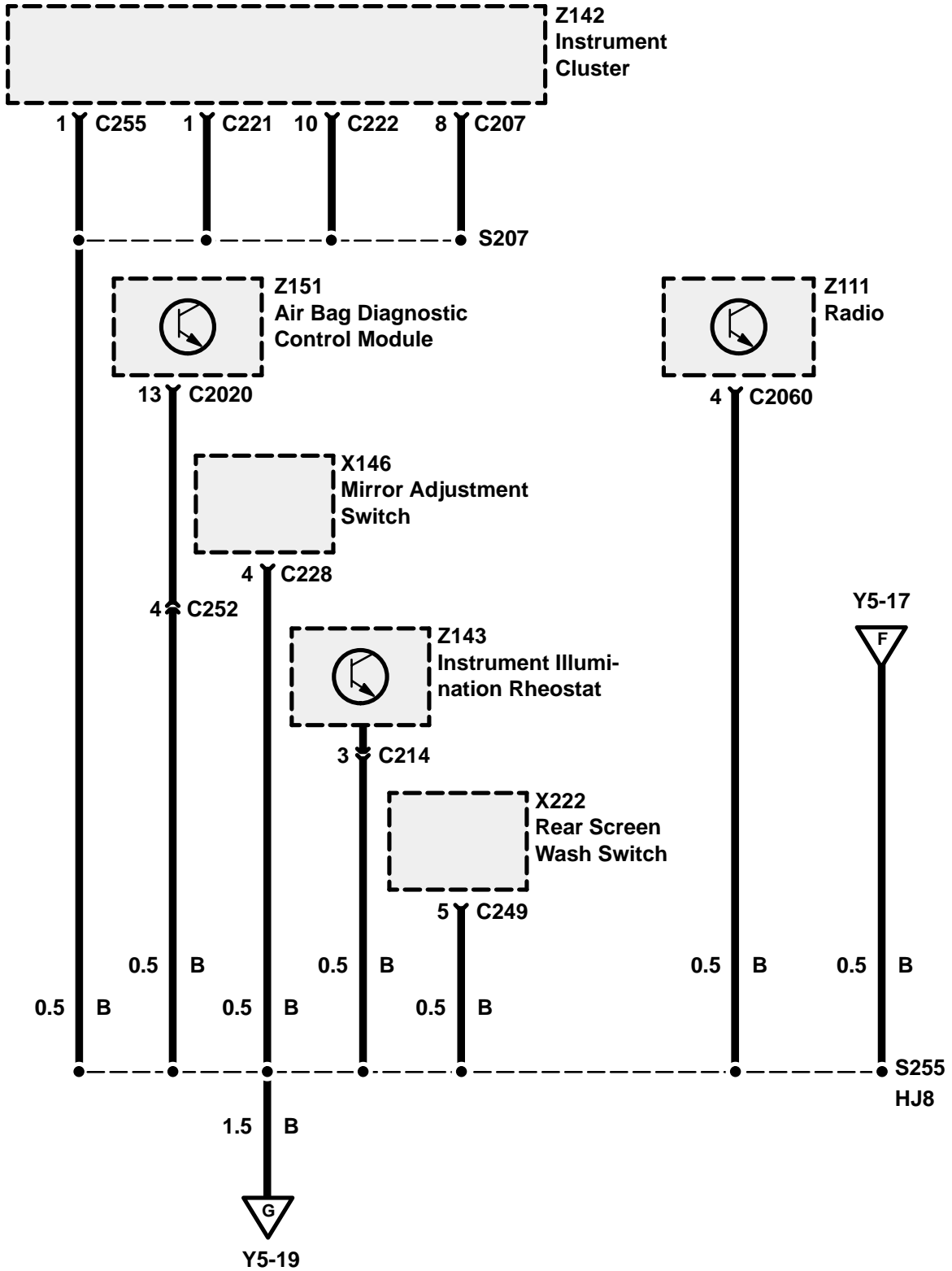
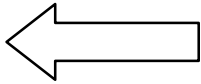

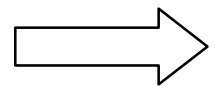
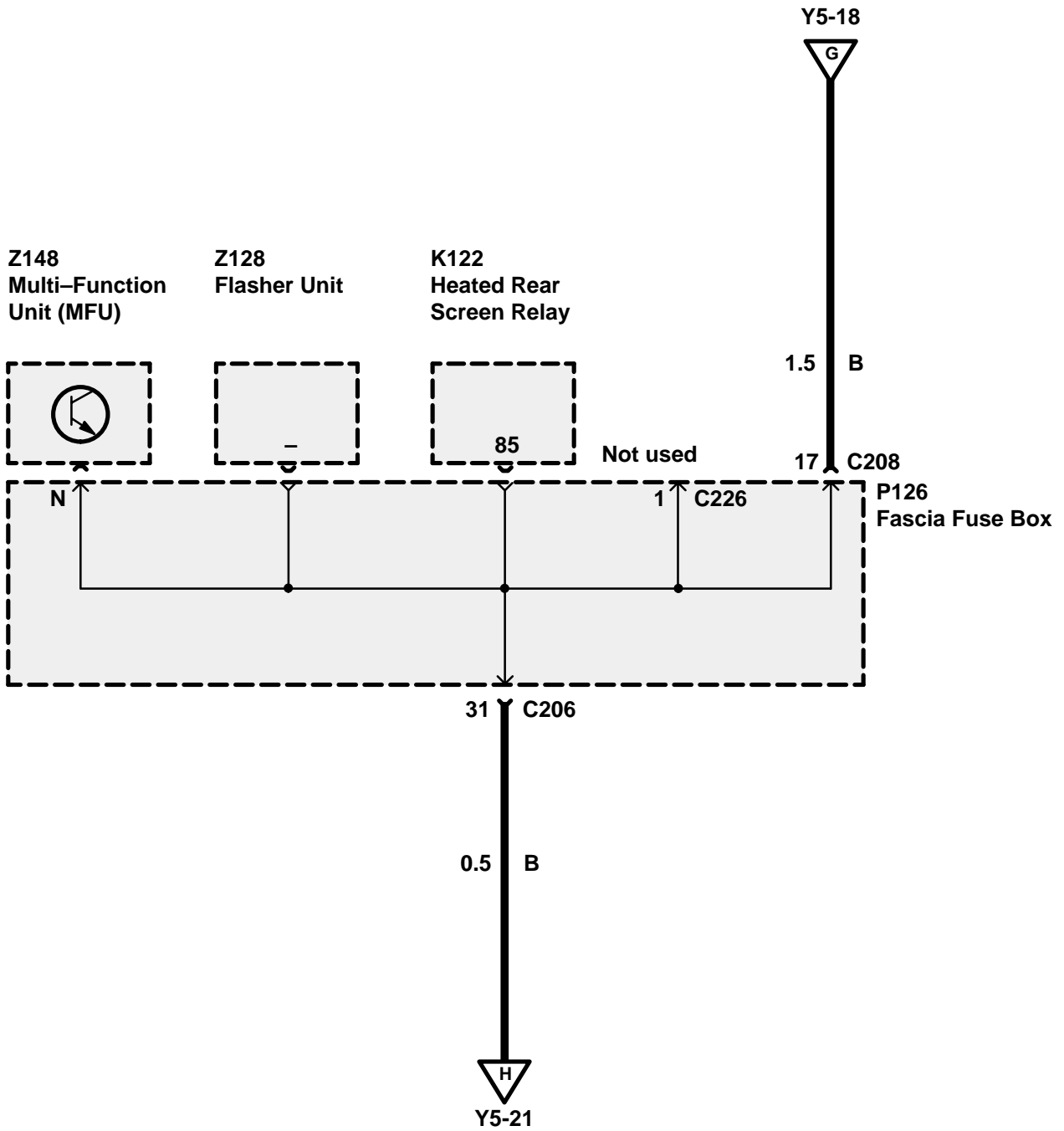
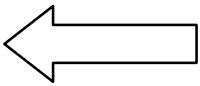

# Y5 ETM

## DISCOVERY

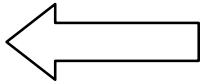

M122  
Right Front Door  
Lock Actuator

4 C607



B133  
Right Mirror De-  
mister

C612

B

1 C603

S601

0.5 B



M122  
Right Front Door  
Lock Actuator

3 C607



B133  
Right Mirror De-  
mister

C612

B



X202  
Right Front Door  
Key Switch

P

1 C603

4 C604

S601

0.5 B

Without Theft Alarm

With Theft Alarm

2 C602

0.5 B



Y5-21

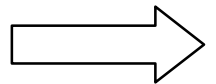



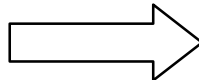
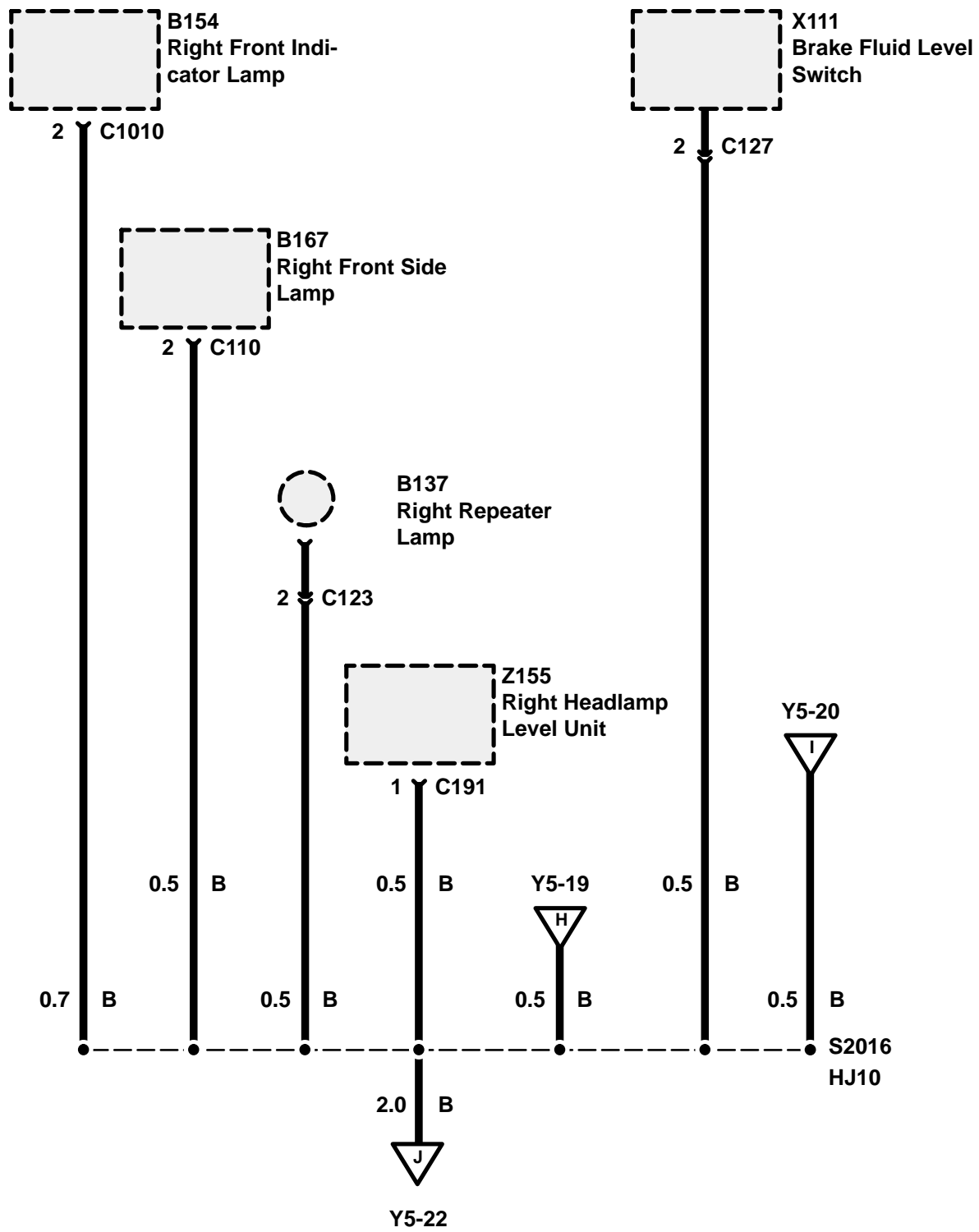
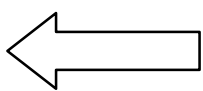

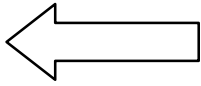

86 C2007



N  
1 C178



2 C179

Not used

S203  
HJ10

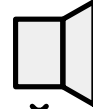

1 C169



1 C175

Z171  
Alarm Sounder

← Except Japan

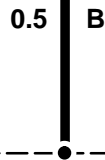
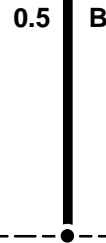
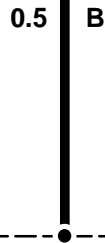

S204  
HJ10

2.0 B

6 C2028



E200  
Partial

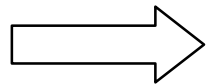

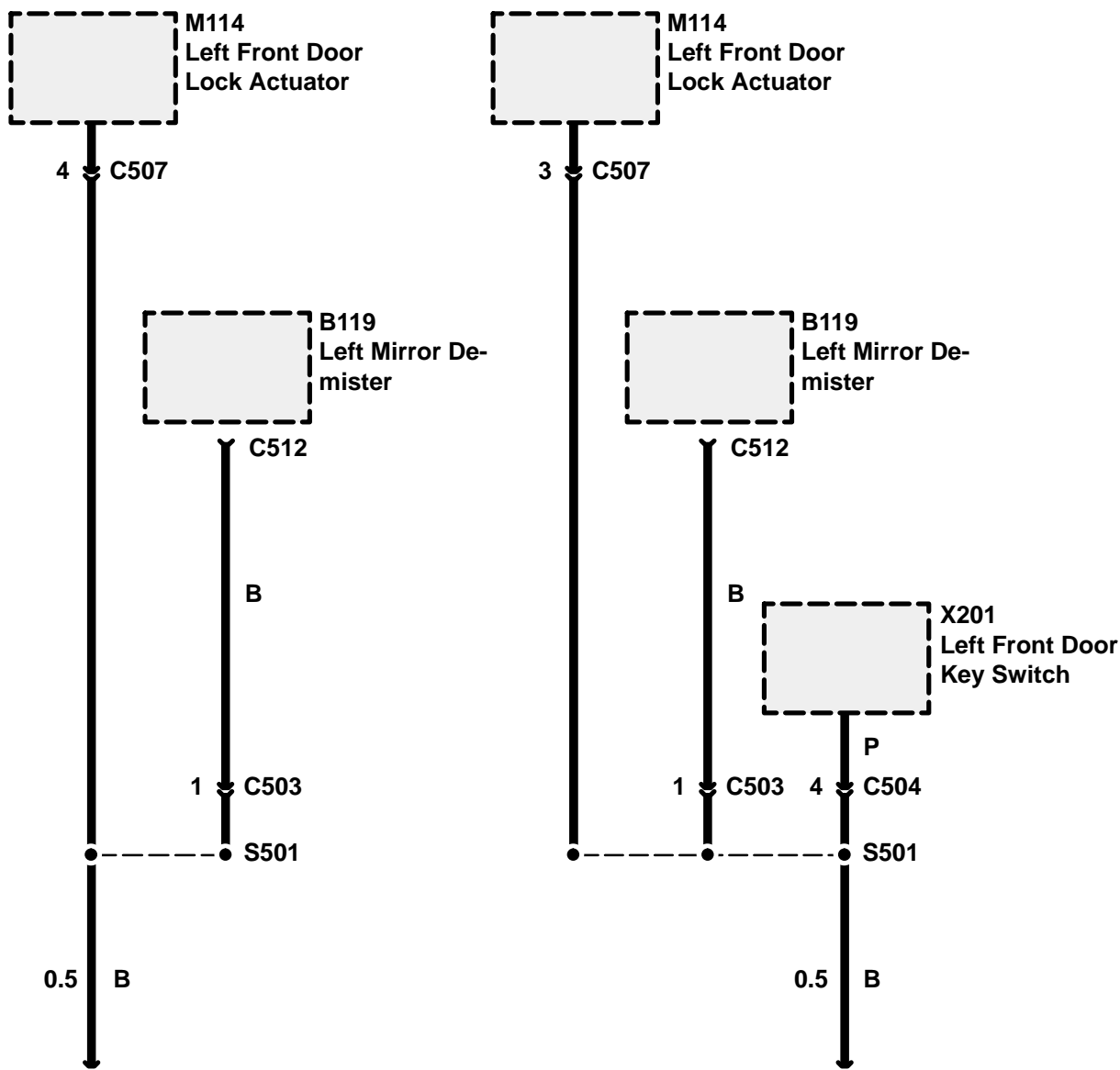
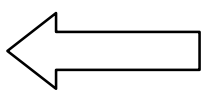

Without Theft Alarm

With Theft Alarm

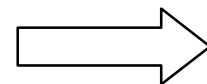
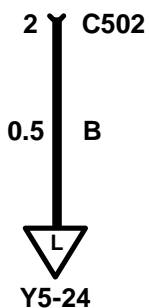

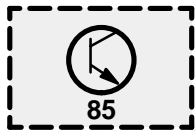
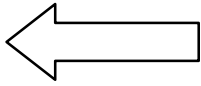

Z164  
Speed Trip Module

85 C2021

Manual Transmission



K174  
Accessory Relay

86 C282

0.5 B



M105  
Front Screen  
Wash Pump

1 C170

6 C218

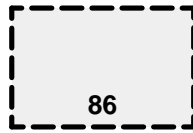

K172  
Catalyst Warning  
Relay

86 C299

0.5 B

0.5 B

0.5 B

0.5 B

S2015  
HJ11

2.0 B



Y5-25



Y5-23

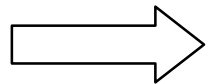

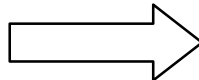
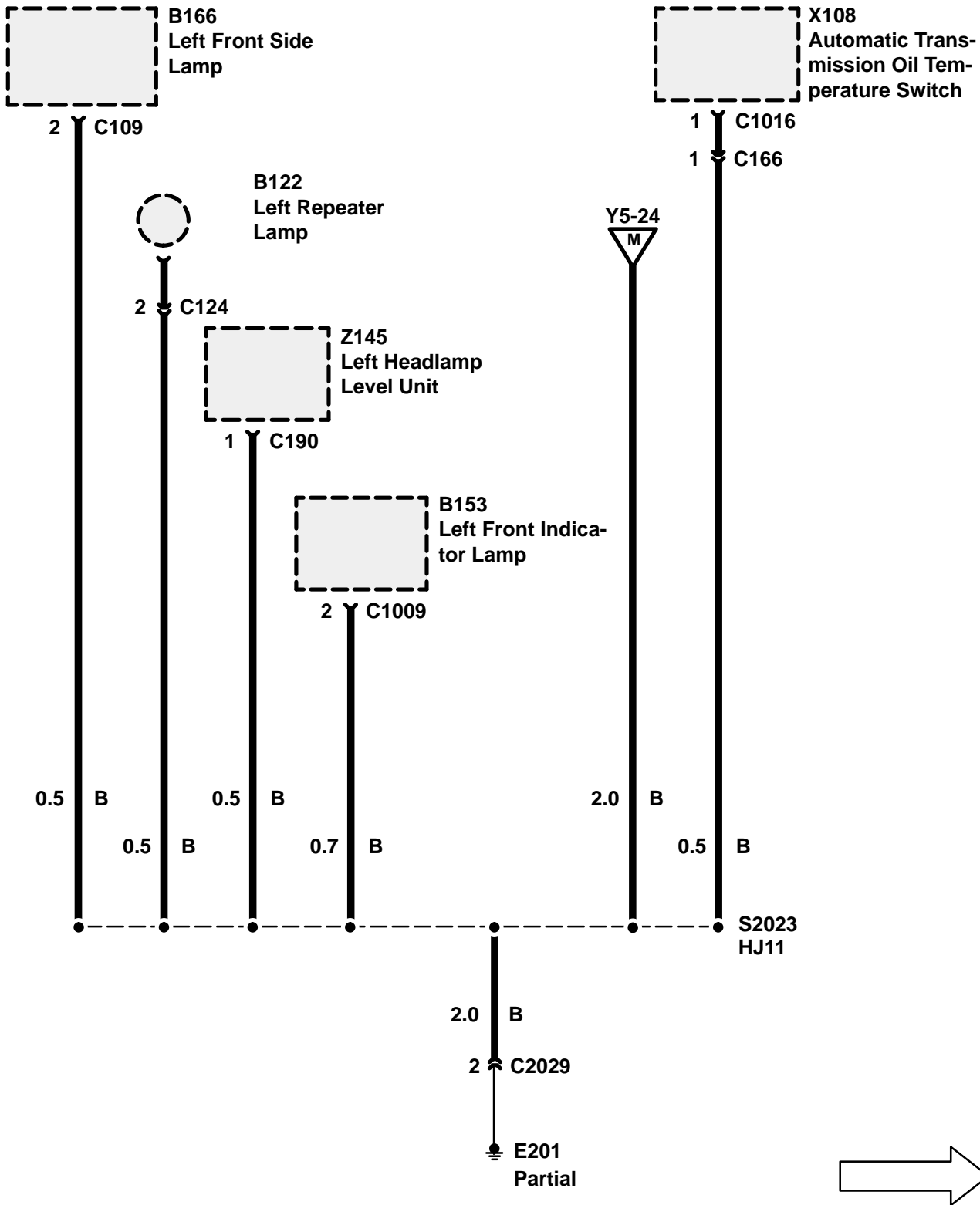
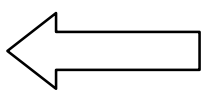

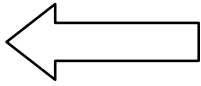

X247  
Front Fan Speed  
Switch



Z214  
Front Blower Re-  
sistor Unit

1 C2022

4 C2070

1 C2027



K192  
Front Blower  
Motor Relay

87a

4 C2068

7 C2066

S266

3.0 WB

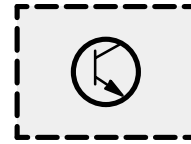

Z147  
Window Lift ECU

C C288

2 C298

2.0 B

3.0 B

3

1 C2029

E201  
Partial

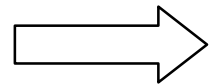



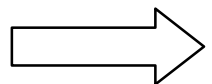
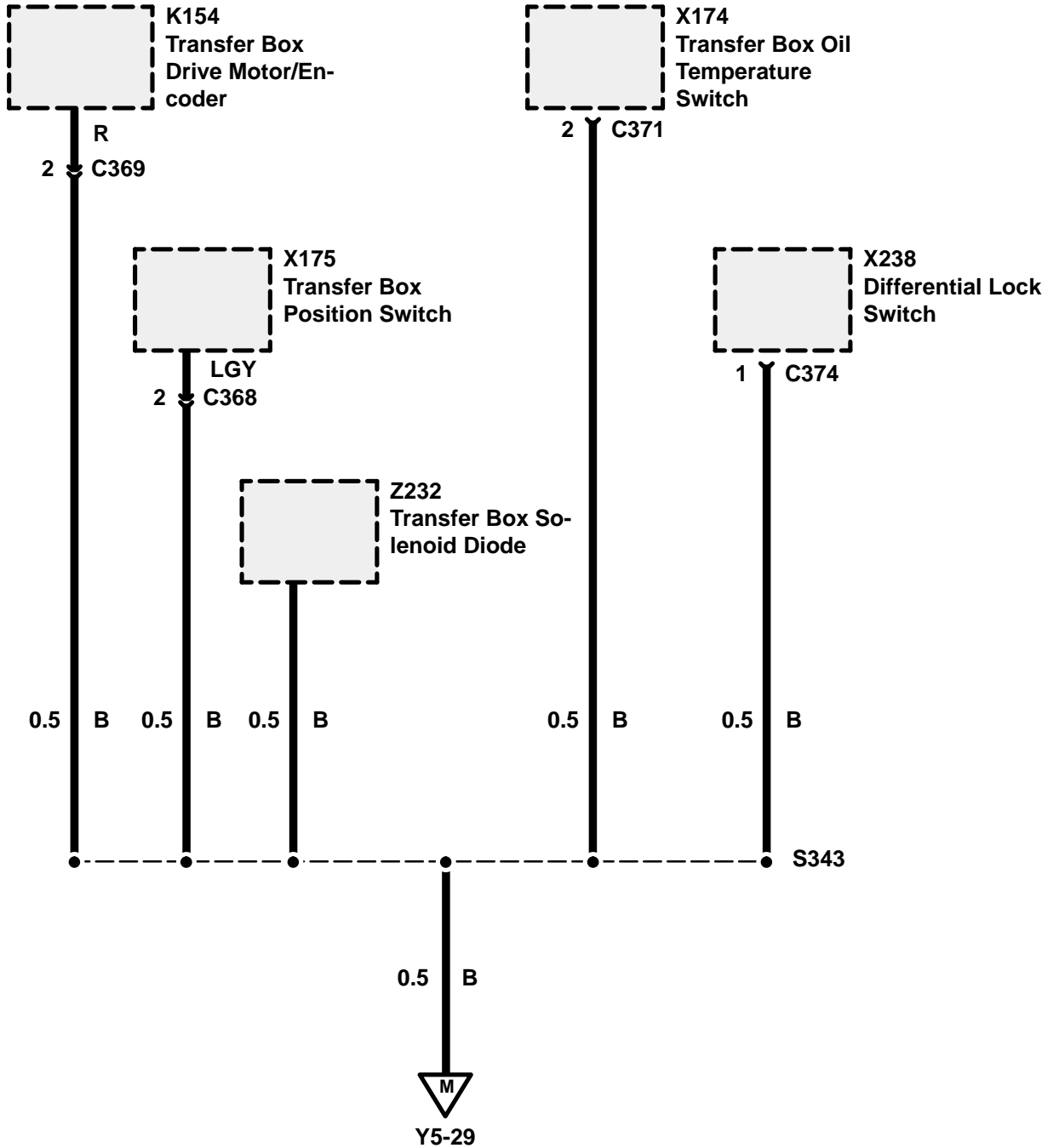
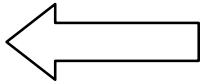



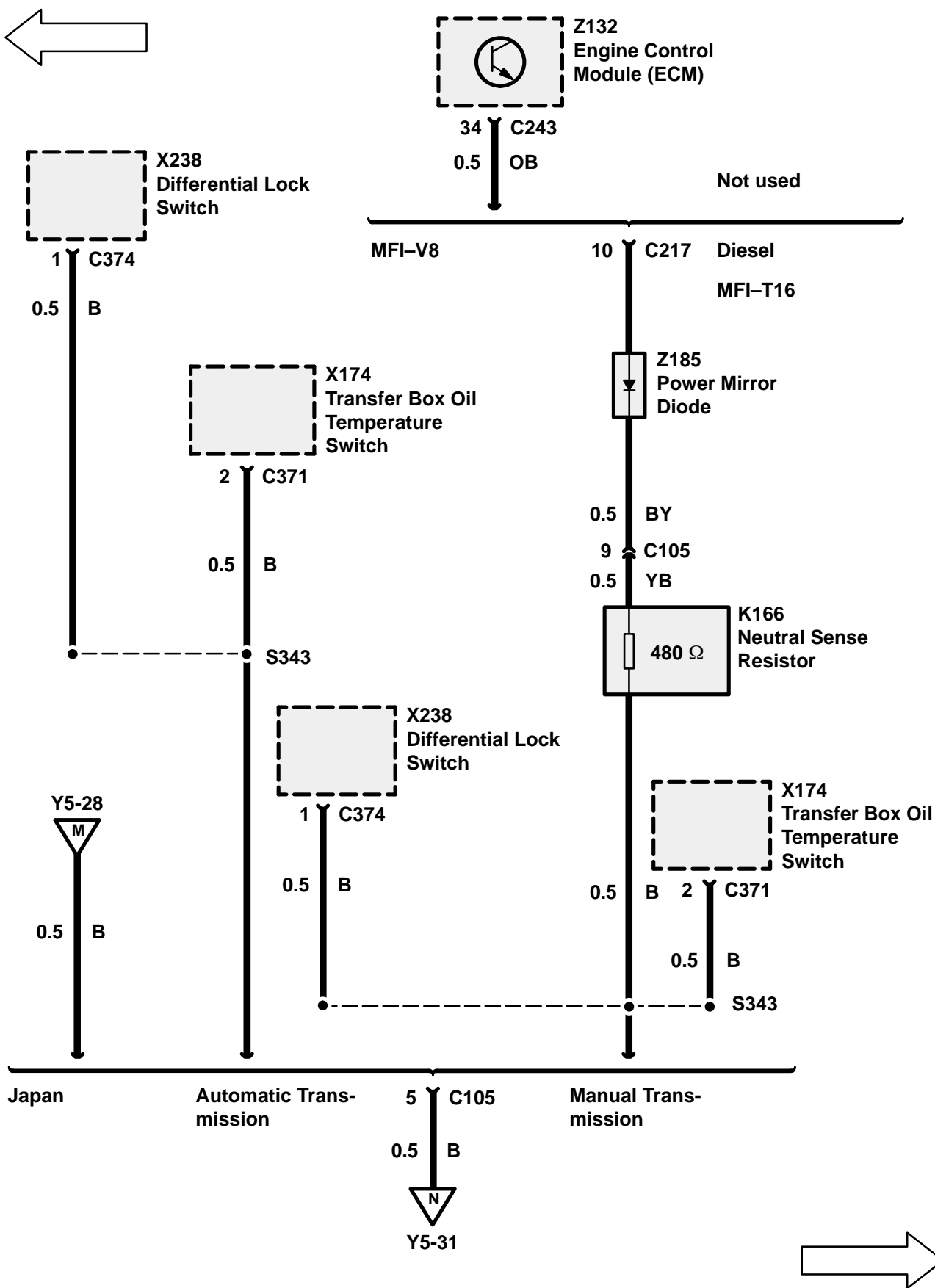

# Y5 ETM

## DISCOVERY

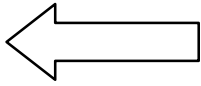

Z121  
Cruise Control  
ECU

8 C284



Z196  
Catalyst Warning  
ECU 1

1 C285



K128  
Left Horn

1 C168

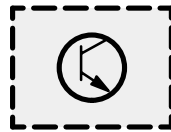

Z198  
Catalyst Warning  
ECU 2

1 C286



K172  
Catalyst Warning  
Relay

87 C299

0.5 B

1.5 B

0.5 B

0.5 B

0.5 B

S288  
HJ5

2.0 B



Y5-31

Japan

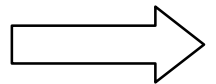

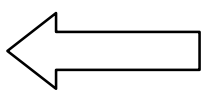

M119  
Rear Screen  
Wash Pump

1 C120



M110  
Headlamp Wash  
Pump

B  
2 C173



Z110  
Transmission  
Range Selector  
Switch

BW  
3 C344

With Shift Inter-  
lock



Y5-29  
N



Y5-30  
O

0.5 B

1.5 B

0.5 B

2.0 B

0.5 B



S2031  
HJ5

2.0 B

5 C2029

E201  
Partial

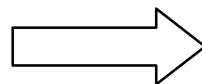



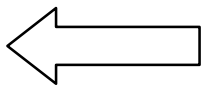

B106  
Fascia Cigar  
Lighter

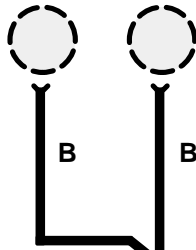

B102  
Automatic Gear  
Selector Illumi-  
nation



1 C353

2 C346

1.0 B

0.5 B

0.5 BO

S2032  
HJ3



K183  
Rear Wiper Relay

X104  
A.B.S. Diagnos-  
tic Connector



K187  
Power Amplifier  
Relay

87a C281

5 C313

86 C2053

Japan

0.5 B

1.0 B

0.5 B

S2003  
HJ3

1.5 B



Y5-34



Y5-34

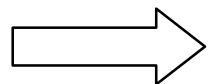

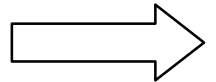
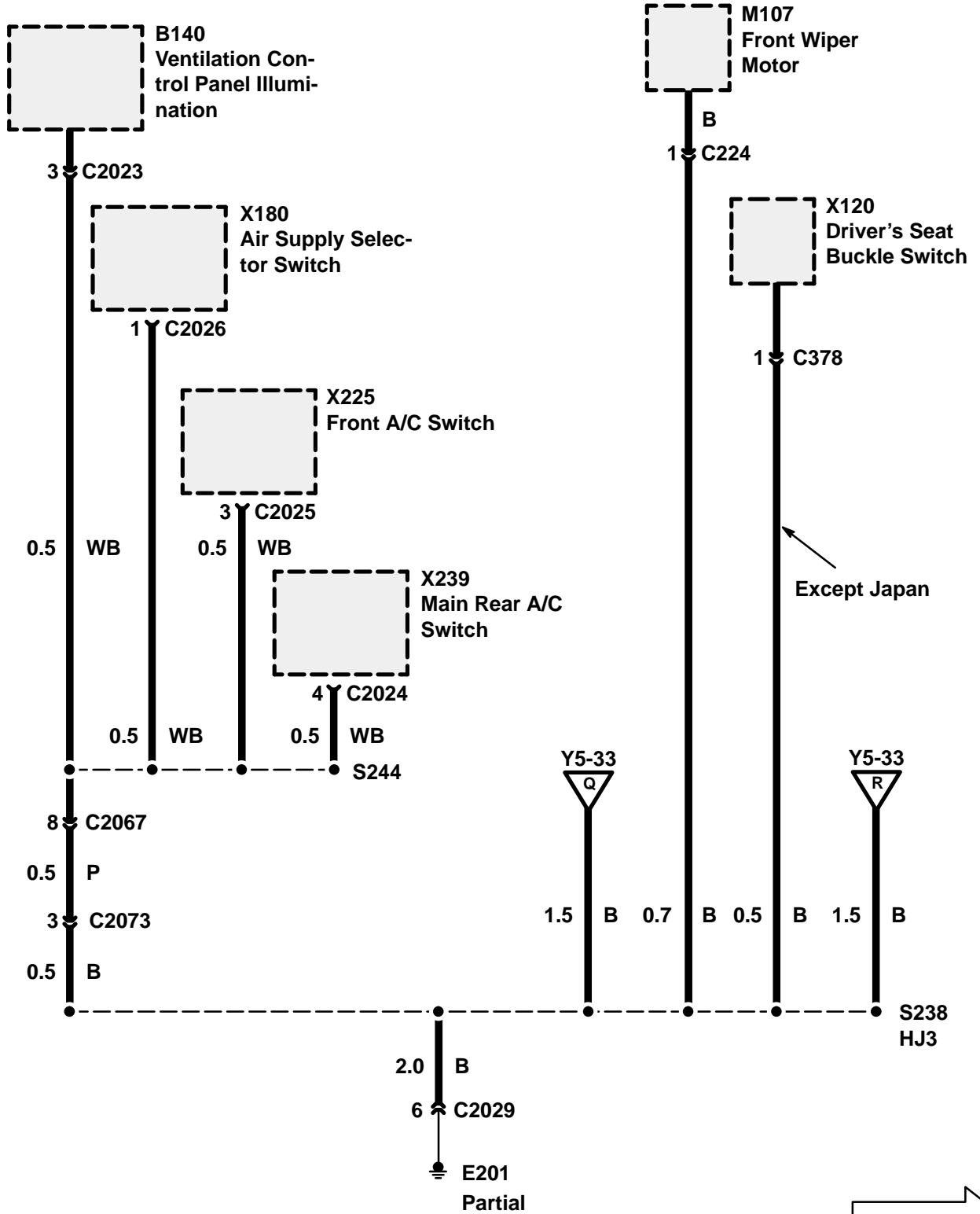
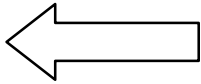



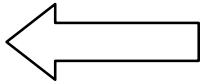

X122  
Left Front Win-  
dow Switch

4 C337

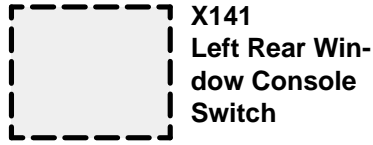

X141  
Left Rear Win-  
dow Console  
Switch

4 C339

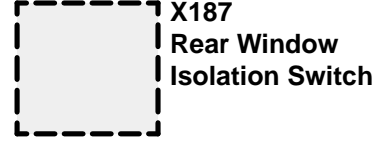

X187  
Rear Window  
Isolation Switch

1 C343

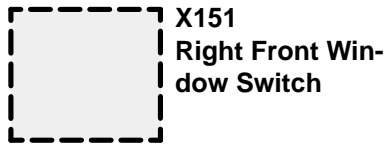

X151  
Right Front Win-  
dow Switch

4 C338



X162  
Right Rear Win-  
dow Console  
Switch

4 C340

0.5 B

0.5 B

1.5 B

1.5 B

1.5 B

2

1

3

4

5 S2031

E303

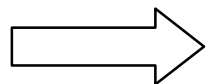



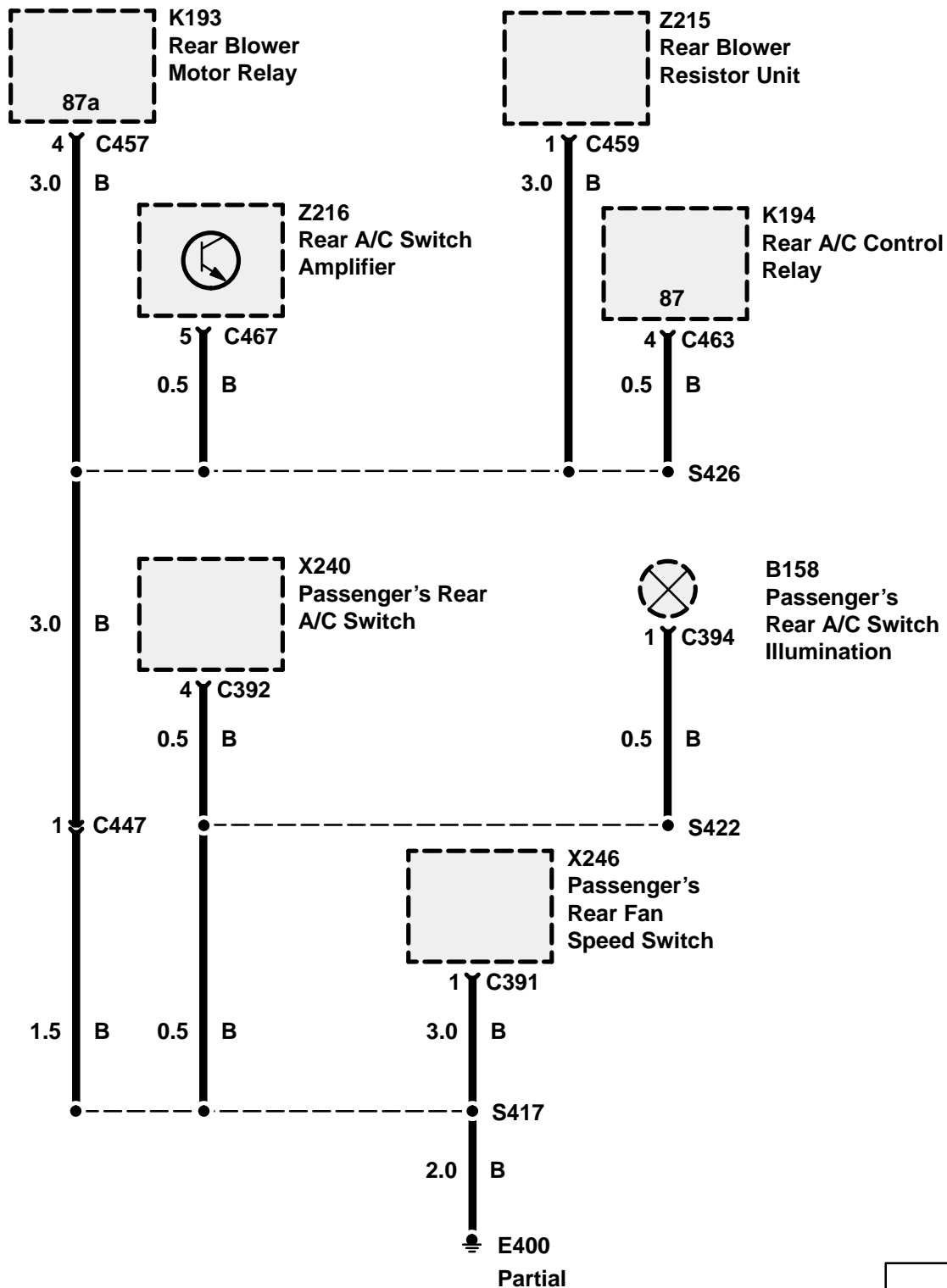
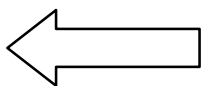

# Y5 ETM

## DISCOVERY

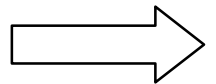
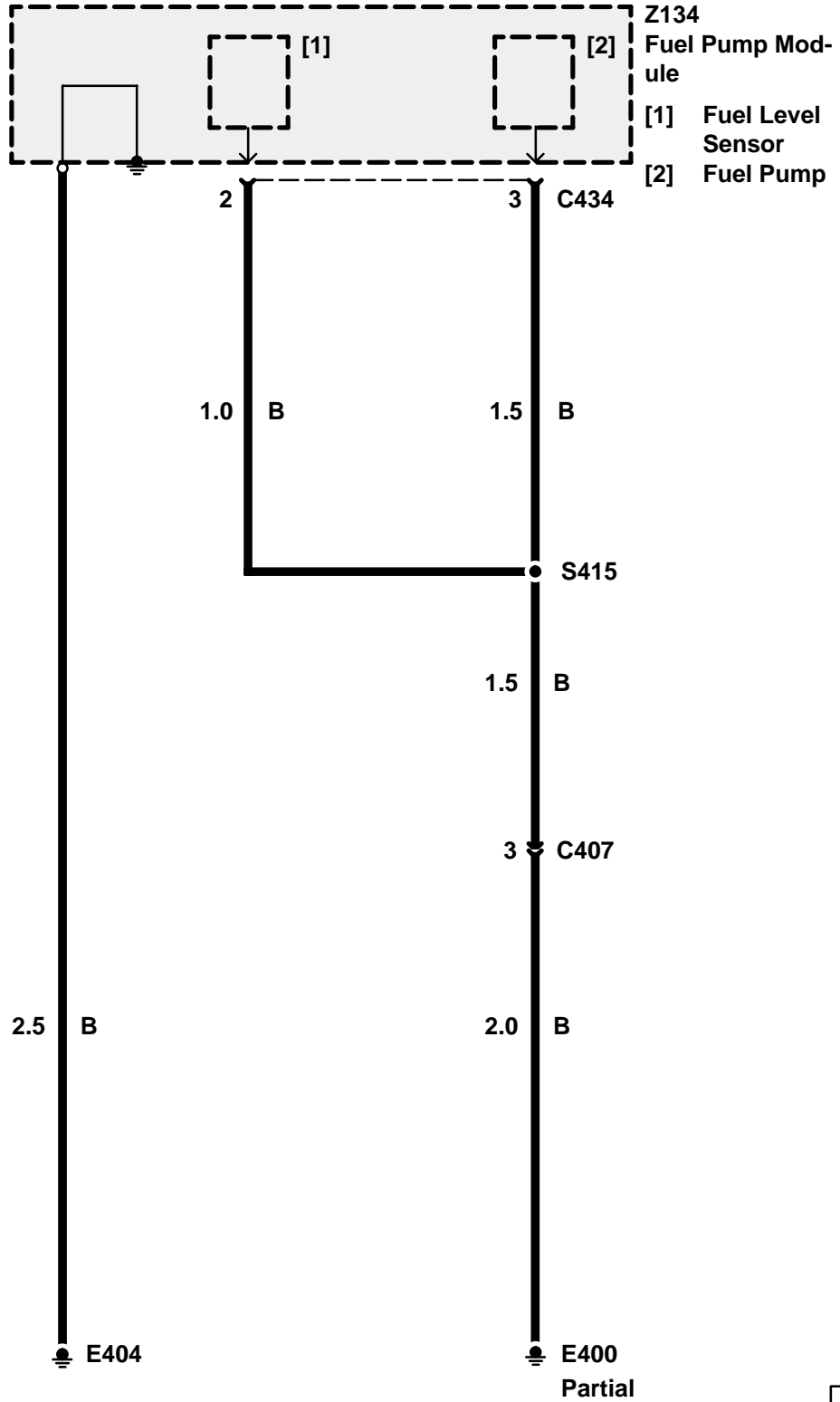
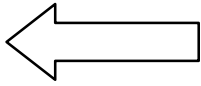

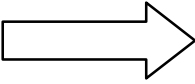
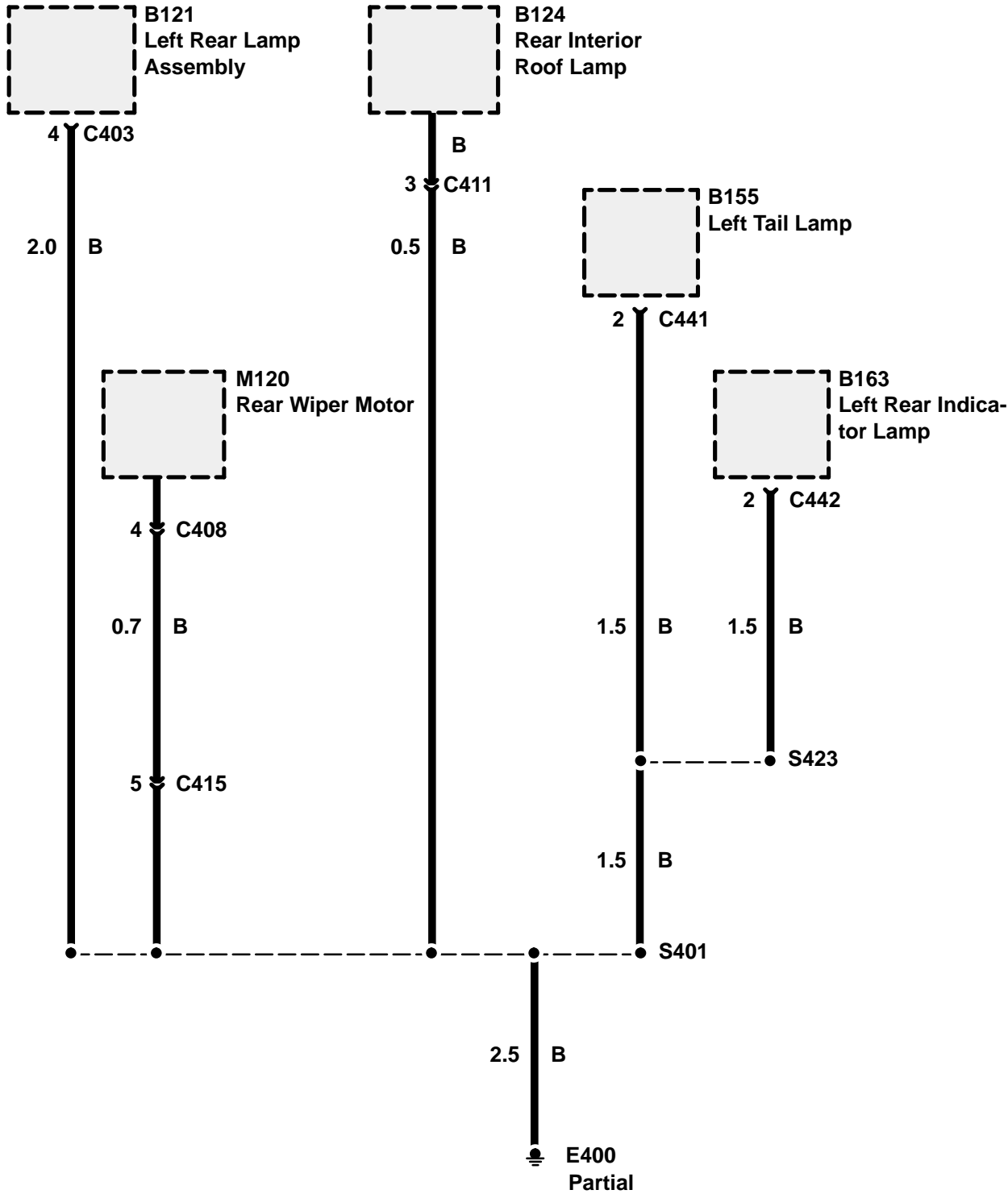
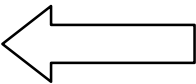

# Y5 ETM

## DISCOVERY

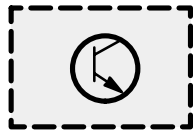
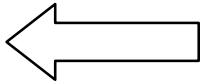

Z176  
Subwoofer Am-  
plifier

6 C412

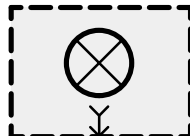

B103  
Centre Mounted  
Stop Lamp

1 C484



B123  
Number Plate  
Lamps

1 C404



B123  
Number Plate  
Lamps

1 C404

S418

With Subwoofer

Without Subwoofer

0.5 B



Y5-41

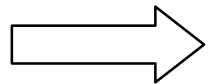

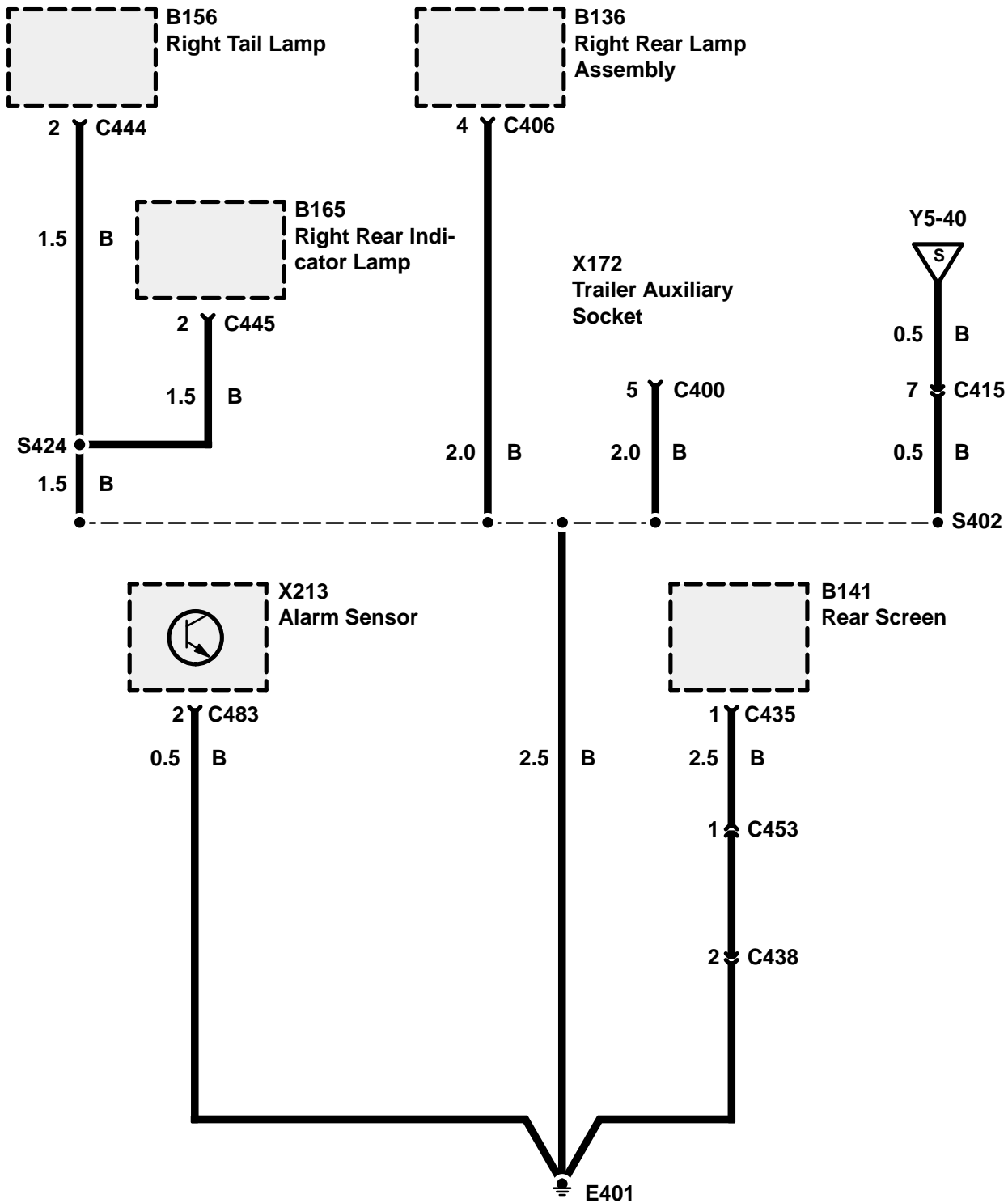
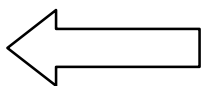

Component	Location	Manual	View
A.B.S. Booster Unit (Z103) ..	LH rear corner of engine compartment .....	70 .....	4
A.B.S. Diagnostic Connector (X104) .....	behind RH side of fascia near Fascia Fuse Box ....	70	
A.B.S. Hydraulic Pump (M102) .....	LH rear corner of engine compartment .....	70 .....	4
A.B.S. Load Relay (K101) ...	behind LH side of fascia on bracket .....	70 .....	96
A.B.S. Pump Relay (K102) ..	behind LH side of fascia on bracket .....	70 .....	96
A.B.S. Warning Relay (K103)	behind LH side of fascia on bracket .....	70 .....	96
A/C Dual Pressure Switch (X102) .....	RH rear corner of engine compartment .....	82 .....	70
A/C Logic Relay (K170) .....	behind RH footwell trim panel .....	82 .....	155
Accessory Relay (K174) .....	behind LH footwell trim panel .....	86 .....	86
Air Bag Diagnostic Control Module (Z151) .....	beneath centre console .....	76 .....	112
Air Recirculation Solenoid (K123) .....	behind LH side of fascia LH side of heater evaporator unit .....	82 .....	91
Air Recirculation Solenoid In-Line Fuse (P138) .....	behind LH side of fascia .....	82 .....	98
Air Supply Selector Diode (Z208) .....	Heater Switch Wire Harness near C2067 .....	82 .....	103
Air Supply Selector Switch (X180) .....	centre of fascia .....	82 .....	107
Alarm Bonnet Switch (X212) 300Tdi .....	RH front of engine compartment .....	86 .....	39
Alarm Bonnet Switch (X212) MFI – V8 MFI – T16 .....	RH front of engine compartment .....	86 .....	37
Alarm Sensor (X213) .....	front centre of roof .....	86 .....	115
Alarm Sounder (Z171) 300Tdi	RH front of engine compartment .....	86 .....	39
Alarm Sounder (Z171) MFI – V8 MFI – T16 .....	RH front of engine compartment .....	86 .....	37
Anti-Lock Brake System ECU (Z108) .....	behind LH side of fascia on bracket .....	70 .....	97
Automatic Gear Selector Illumination (B102) .....	beneath centre console .....	86	
Automatic Transmission Oil Temperature Switch (X108)	lower LH front of engine compartment .....	86 .....	24
Boost Pressure Air Temperature Sensor (X254) .....	top centre front of engine .....	19 .....	20
Boost Pressure Sensor (X253) .....	LH rear of engine compartment .....	19 .....	11
Brake Fluid Level Switch (X111) .....	RH rear corner of engine compartment top of brake fluid reservoir .....	70 .....	72
Brake Switch Vent Valve (X112) .....	behind RH side of fascia on brake pedal support ...	19 .....	126

<b>Component</b>	<b>Location</b>	<b>Manual</b>	<b>View</b>
Catalyst Thermocouple 1 (X243)	LH side of transmission	86	77
Catalyst Thermocouple 2 (X244)	LH side of transmission	86	77
Catalyst Warning ECU 1 (Z196)	behind LH side of fascia	86	89
Catalyst Warning ECU 2 (Z198)	behind LH side of fascia	86	88
Catalyst Warning Relay (K172)	behind LH side of fascia	86	
CD Changer (Z114)	beneath LH front seat	86	
Central Locking Control Unit (Z113)	behind LH side of fascia on bracket	86	93
Clock (Z117)	centre of fascia	86	
Clutch Pedal Position Switch (X200)	behind RH side of fascia near steering column	86	
Column Switch Illumination (B104)	top of steering column on Ignition Switch	86	137
Compressor Clutch (K107) 300Tdi with EDC	RH side of engine on front of A/C compressor	82	50
Compressor Clutch (K107) 300Tdi without EDC	RH side of engine on front of A/C compressor	82	49
Compressor Clutch (K107) MFI – T16	RH side of engine on front of A/C compressor	82	
Compressor Clutch (K107) MFI – V8	RH side of engine on front of A/C compressor	82	41
Compressor Clutch Cut–out Switch (X259)	RH front of engine	82	45
Compressor Clutch Relay (K108)	behind RH footwell trim panel	82	154
Condenser Fan Control Diode 1 (Z209)	Engine Wire Harness near C217	82	
Condenser Fan Control Diode 2 (Z210)	Engine Wire Harness near C217	82	121
Condenser Fan Coolant Temperature Switch (X113) 300Tdi with EDC	RH front of engine on thermostat housing	82	44
Condenser Fan Coolant Temperature Switch (X113) MFI – V8	top centre front of engine	82	55
Condenser Fan Coolant Temperature Switch (X113) 300Tdi without EDC	RH front of engine	82	46
Condenser Fan Relay (K109)	behind LH side of fascia on bracket	86	95
Cooling Fan Motor 1 (M141) MFI – T16 with Air Conditioning	front of engine compartment	82	

Component	Location	Manual	View
Cooling Fan Motor 1 (M141) MFI – T16 without Air Conditioning .....	front of engine compartment .....	82 .....	31
Cooling Fan Motor 2 (M142) .	front of engine compartment .....	82	
Cooling Fan Relay (K190) ...	behind RH footwell trim panel .....	82 .....	150
Crankshaft Position Sensor (X250) .....	lower RH rear of engine .....	19 .....	65
Cruise Control Diode (Z186) .	Cruise Control Wire Harness near C218 .....	19	
Cruise Control ECU (Z121) ..	behind LH side of fascia on bracket .....	19 .....	90
Cruise Control Lockout Relay (K110) .....	behind LH side of fascia on bracket .....	19	
Cruise Control Switch (X115)	centre of fascia .....	19	
Cruise Control Vacuum Pump (M103) .....	LH front corner of engine compartment .....	19 .....	21
Data Link Connector (EGR) (X219) 300Tdi with EGR ...	behind RH side of fascia .....	19 .....	157
Data Link Connectors (X127) 300Tdi with EDC .....	behind RH side of fascia .....	19 .....	156
Data Link Connectors (X127) MFI – T16 .....	RH rear corner of engine compartment .....	19 .....	68
Data Link Connectors (X127) MFI – V8 .....	behind RH side of fascia .....	19 .....	156
Differential Lock Switch (X238) .....	top RH side of transfer box .....	86 .....	83
Dim/Dip Relay (K176) .....	behind LH side of fascia on bracket .....	86 .....	95
Dim/Dip Resistor (K175) ....	LH rear of engine compartment .....	86 .....	3
Direction Indicator Diode 1 (Z212) .....	behind instrument cluster .....	86 .....	141
Direction Indicator Diode 2 (Z213) .....	behind instrument cluster .....	86 .....	140
Direction Indicator Switch (X116) .....	top of steering column .....	86 .....	129
Distributor (Z125) MFI – T16 .	top rear of engine .....	86	
Distributor (Z125) MFI – V8 ..	top centre front of engine .....	86 .....	17
Driver's Seat Buckle Switch (X120) .....	inside driver's seat belt buckle assembly .....	86	
EDC Stop Lamp Switch (X252) .....	behind RH side of fascia on brake pedal support ...	19 .....	124
EGR Control Solenoid (K171)	LH front of engine compartment .....	19 .....	23
EGR Valve Control Module (Z149) .....	behind RH side of fascia .....	19 .....	157
EGR Valve Position Sensor (X218) .....	LH side of engine .....	19 .....	7
Engine Compartment Fuse Box (P125) 300Tdi .....	RH front of engine compartment .....	86 .....	38



<b>Component</b>	<b>Location</b>	<b>Manual</b>	<b>View</b>
Engine Compartment Fuse Box (P125) MFI – V8 MFI – T16 .....	RH front of engine compartment .....	86 .....	36
Engine Control Load Relay (K116) .....	behind RH footwell trim panel .....	19 .....	153
Engine Control Module (ECM) (Z132) 300Tdi with EDC ...	behind RH side of fascia .....	19 .....	156
Engine Control Module (ECM) (Z132) MFI – T16 .....	RH rear corner of engine compartment .....	19 .....	69
Engine Control Module (ECM) (Z132) MFI – V8 .....	behind RH side of fascia .....	19 .....	156
Engine Coolant Temperature Gauge Sensor (X114) 300Tdi with EDC .....	RH front of engine on thermostat housing .....	86 .....	44
Engine Coolant Temperature Gauge Sensor (X114) 300Tdi without EDC .....	RH front of engine .....	86 .....	45
Engine Coolant Temperature Gauge Sensor (X114) MFI – T16 .....	LH front of engine .....	86 .....	15
Engine Coolant Temperature Gauge Sensor (X114) MFI – V8 .....	top centre front of engine on intake manifold .....	86 .....	13
Engine Coolant Temperature Sensor (X126) 300Tdi with EDC .....	top centre front of engine .....	19 .....	20
Engine Coolant Temperature Sensor (X126) 300Tdi without EDC .....	top centre front of engine .....	19 .....	19
Engine Coolant Temperature Sensor (X126) MFI – T16 ..	LH front of engine .....	19 .....	15
Engine Coolant Temperature Sensor (X126) MFI – V8 ...	top centre front of engine on intake manifold .....	19 .....	13
Engine Fuel Temperature Sensor (X128) MFI – T16 ..	RH side of engine .....	19 .....	43
Engine Fuel Temperature Sensor (X128) MFI – V8 ...	top centre front of engine .....	19 .....	13
Engine Speed Sensor (X255)	RH rear of engine .....	19 .....	62
Evaporative Emission Canister Purge Valve (K132) MFI – T16 .....	RH rear corner of engine compartment .....	17 .....	68
Evaporative Emission Canister Purge Valve (K132) MFI – V8 .....	RH side of engine compartment .....	17 .....	67
Fan Control Module (Z118) ..	behind RH footwell trim panel .....	82 .....	154
Fan Timer Diode (Z211) .....	Main Wire Harness near HJ3 .....	82 .....	100
Fascia Cigar Lighter (B106) ..	in front of centre console .....	86 .....	108

Component	Location	Manual	View
Fascia Fuse Box (P126) . . . . .	behind RH side of fascia . . . . .	86 . . . . .	142
Flasher Unit (Z128) . . . . .	behind RH side of fascia on Fascia Fuse Box . . . . .	86 . . . . .	143
Front A/C Evaporator Temperature Switch (X101) . . . . .	LH side of heater evaporator unit . . . . .	82 . . . . .	104
Front A/C Switch (X225) . . . . .	centre of fascia . . . . .	82 . . . . .	105
Front Blower Motor (M101) . . . . .	behind LH side of fascia LH side of heater evaporator unit . . . . .	82 . . . . .	99
Front Blower Motor Relay (K192) . . . . .	behind LH side of fascia . . . . .	82 . . . . .	98
Front Blower Resistor Unit (Z214) . . . . .	behind LH side of fascia LH side of heater evaporator unit . . . . .	80 . . . . .	103
Front Fan Speed Switch (X247) . . . . .	centre of fascia . . . . .	82 . . . . .	105
Front Interior Roof Lamp (B107) . . . . .	front centre of roof . . . . .	86 . . . . .	115
Front Screen Wash Pump (M105) . . . . .	LH rear of engine compartment . . . . .	84 . . . . .	2
Front Sunroof Motor (M143) . . . . .	front centre of roof . . . . .	76 . . . . .	116
Front Sunroof Switch (X261) . . . . .	front centre of roof . . . . .	76 . . . . .	117
Front Wipe/Wash Switch (X124) . . . . .	top of steering column . . . . .	84 . . . . .	138
Front Wiper Motor (M107) . . . . .	RH side of bulkhead . . . . .	84 . . . . .	73
Front Wiper Relay (K185) . . . . .	behind RH footwell trim panel . . . . .	84 . . . . .	152
Fuel Injector Assembly (K195) . . . . .	RH side of engine . . . . .	19 . . . . .	53
Fuel Injectors (K141) MFI – T16 . . . . .	top centre front of engine . . . . .	19 . . . . .	18
Fuel Injectors (K141) MFI – V8 . . . . .	top centre front of engine . . . . .	19 . . . . .	12
Fuel Pump Assembly (K196) . . . . .	RH side of engine . . . . .	19 . . . . .	52
Fuel Pump Module (Z134) . . . . .	top of fuel tank . . . . .	86 . . . . .	188
Fuel Pump Relay (K119) . . . . .	behind RH footwell trim panel . . . . .	86 . . . . .	153
Fuel Shut–Off Solenoid (K111) 300Tdi with EGR . . . . .	RH side of engine on injector pump . . . . .	19 . . . . .	48
Fuel Shut–Off Solenoid (K111) 300Tdi without EGR . . . . .	RH side of engine on injector pump . . . . .	19 . . . . .	47
Fusible Link (P119) . . . . .	RH front of engine compartment behind battery . . . . .	86 . . . . .	38
Generator (Z106) 300Tdi . . . . .	lower LH side of engine . . . . .	86 . . . . .	16
Generator (Z106) MFI – T16 with Air Conditioning . . . . .	LH front of engine . . . . .	86 . . . . .	
Generator (Z106) MFI – T16 without Air Conditioning . . . . .	RH side of engine . . . . .	86 . . . . .	58
Generator (Z106) MFI – V8 . . . . .	top centre front of engine . . . . .	86 . . . . .	56

Component	Location	Manual	View
Generator Suppression Capacitor (Z182) 300Tdi	lower LH side of engine on Generator	86	16
Generator Suppression Capacitor (Z182) MFI – T16 with Air Conditioning	LH front of engine on Generator	86	
Generator Suppression Capacitor (Z182) MFI – T16 without Air Conditioning	RH side of engine on Generator	86	58
Generator Suppression Capacitor (Z182) MFI – V8	top centre front of engine on Generator	86	56
Glow Plug Timer Unit (Z135)	RH front of engine compartment	19	39
Glow Plugs (P120)	RH side of engine	19	51
Handbrake Switch (X191)	beneath centre console on handbrake lever	86	114
Hazard Switch (X220)	centre of fascia	86	
Headlamp Level Switch (X130)	top RH side of fascia	86	
Headlamp Wash Pump (M110)	LH rear of engine compartment	86	2
Heated Rear Screen Relay (K122)	behind RH side of fascia on Fascia Fuse Box	86	143
Heated Rear Screen Switch (X132)	top RH side of fascia near Instrument Cluster	86	133
Horn Relay (K189)	behind LH footwell trim panel	86	86
Horn Switches (X258)	in steering wheel	86	128
Idle Air Control Valve (M112) MFI – T16	RH front of engine	19	42
Idle Air Control Valve (M112) MFI – V8	top rear of engine	19	57
Ignition Coil (Z140) MFI – V8	LH front corner of engine compartment	86	29
Ignition Coil 1 (Z217) MFI – T16	top rear of engine	86	
Ignition Coil 2 (Z218) MFI – T16	top rear of engine	86	
Ignition Coil Noise Suppressor (Z237)	LH front corner of engine compartment on Ignition Coil	86	29
Ignition Control Module (Z139)	top centre front of engine attached to distributor	86	17
Ignition Key Lock Solenoid (K191)	top of steering column	86	132
Ignition Load Relay (K127)	behind RH footwell trim panel	86	151
Ignition Switch (X134)	top of steering column	86	130
Inertia Fuel Shut-Off Switch (X135)	LH rear of engine compartment	19	1
Injector Needle Lift Sensor (X256)	RH rear of engine	19	62

Component	Location	Manual	View
Instrument Cluster (Z142) . . .	top RH side of fascia . . . . .	86	
Instrument Illumination Rheostat (Z143) . . . . .	top RH side of fascia near Instrument Cluster . . . . .	86	
Intake Air Temperature Sensor (X248) . . . . .	RH rear of engine . . . . .	19	
Interlock Diode 1 (Z189) . . . . .	Main Wire Harness near Cruise Control ECU . . . . .	86	
Interlock Diode 2 (Z190) . . . . .	Main Wire Harness near Cruise Control ECU . . . . .	86	
Interlock Relay 1 (K153) . . . . .	behind LH side of fascia . . . . .	86	
Interlock Relay 2 (K151) . . . . .	behind LH side of fascia . . . . .	86	
Key-Barrel Switch (X230) . . . . .	top of steering column on Ignition Switch . . . . .	86	131
Key-In Switch (X229) . . . . .	top of steering column on Ignition Switch . . . . .	86	130
Knock Sensor (X249) . . . . .	RH side of engine . . . . .	19	43
Left Condenser Fan Motor (M113) . . . . .	behind front grille . . . . .	86	32
Left Front Door Key Switch (X201) . . . . .	in top rear of LH front door at door handle . . . . .	86	161
Left Front Door Lock Actuator (M114) . . . . .	in rear of LH front door . . . . .	76	160
Left Front Door Switch (X150) . . . . .	front of LH front door jamb . . . . .	86	158
Left Front Indicator Lamp (B153) . . . . .	LH front of vehicle . . . . .	86	26
Left Front Side Lamp (B166) . . . . .	LH front of engine compartment . . . . .	86	27
Left Front Wheel Speed Sensor (X137) . . . . .	behind LH front wheel . . . . .	70	75
Left Front Window Motor (M130) . . . . .	in front of LH front door . . . . .	86	162
Left Front Window Switch (X122) . . . . .	in rear of centre console . . . . .	86	110
Left Headlamp (B116) . . . . .	LH front of engine compartment . . . . .	86	28
Left Headlamp Level Unit (Z145) . . . . .	behind LH headlamp . . . . .	86	
Left Heated Oxygen Sensor (X139) MFI – T16 . . . . .	lower LH side of engine compartment . . . . .	19	9
Left Heated Oxygen Sensor (X139) MFI – V8 . . . . .	lower LH side of engine compartment . . . . .	19	74
Left Horn (K128) . . . . .	behind LH side of front grille . . . . .	86	191
Left Maximum Cool Switch (X267) . . . . .	behind heater and A/C control panel . . . . .	82	106
Left Mirror Actuator (M115) . . . . .	top front of LH front door . . . . .	76	159
Left Rear Door Lock Actuator (M117) . . . . .	inside front of LH rear door . . . . .	76	164
Left Rear Door Switch (X142) . . . . .	in lower part of LH B–post . . . . .	86	163
Left Rear Indicator Lamp (B163) . . . . .	LH side of rear bumper . . . . .	86	189

<b>Component</b>	<b>Location</b>	<b>Manual</b>	<b>View</b>
Left Rear Lamp Assembly (B121) .....	LH side of luggage compartment .....	86 .....	173
Left Rear Wheel Speed Sensor (X140) .....	behind LH rear wheel .....	70 .....	76
Left Rear Window Console Switch (X141) .....	in rear of centre console .....	86 .....	111
Left Rear Window Door Switch (X188) .....	inside front of LH rear door .....	86 .....	165
Left Rear Window Motor (M116) .....	inside front of LH rear door .....	86 .....	166
Left Repeater Lamp (B122) ..	LH front side of vehicle .....	86 .....	25
Left Tail Lamp (B155) .....	LH side of rear bumper .....	86 .....	189
Main Lighting Switch (X145) .	top of steering column .....	86 .....	129
Main Rear A/C Switch (X239)	centre of fascia .....	82 .....	107
Mass Air Flow Sensor (X105) 300Tdi with EDC .....	LH rear of engine compartment .....	19 .....	11
Mass Air Flow Sensor (X105) MFI – V8 .....	LH side of engine .....	19 .....	10
Mirror Adjustment Switch (X146) .....	top RH side of fascia right of steering column .....	86	
Multi-Function Relay Unit (Z207) .....	behind RH footwell trim panel .....	19 .....	149
Multi-Function Unit (MFU) (Z148) .....	behind RH side of fascia on Fascia Fuse Box .....	86 .....	145
Multipoint Fuel Injection Ignition Resistor 1 (K115) .....	LH front corner of engine compartment near Ignition Coil .....	86 .....	29
Multipoint Fuel Injection Ignition Resistor 2 (K168) .....	LH front corner of engine compartment near Ignition Coil .....	86 .....	29
Neutral Sense Resistor (K166) .....	Gearbox Wire Harness near C105 .....	86	
Oil Pressure Switch (X149) 300Tdi with EDC .....	lower RH side of engine .....	86 .....	52
Oil Pressure Switch (X149) 300Tdi with EGR .....	lower RH side of engine .....	86 .....	48
Oil Pressure Switch (X149) 300Tdi without EGR .....	lower RH side of engine .....	86 .....	47
Oil Pressure Switch (X149) MFI – T16 .....	lower RH side of engine near oil filter .....	86 .....	35
Oil Pressure Switch (X149) MFI – V8 .....	lower RH side of engine near oil filter .....	86 .....	34
Park/Neutral Position Switch (X167) .....	LH side of transmission .....	86 .....	78
Passenger's Rear A/C Switch (X240) .....	centre of roof .....	82 .....	167
Passenger's Rear Fan Speed Switch (X246) .....	centre of roof .....	82 .....	167

Component	Location	Manual	View
Passenger's Rear Sunroof Switch (X264)	centre of roof	76	119
Phase Tap Resistor (K184) 300Tdi	lower LH side of engine on Generator	86	16
Phase Tap Resistor (K184) MFI – T16 with Air Conditioning	LH front of engine on Generator	86	
Phase Tap Resistor (K184) MFI – T16 without Air Conditioning	RH side of engine on Generator	86	58
Phase Tap Resistor (K184) MFI – V8	top centre front of engine on Generator	86	56
Power Amplifier Relay (K187)	behind LH side of fascia	86	
Power Mirror Diode (Z185)	Main Wire Harness near HJ3	86	100
Power Wash Relay (K182)	behind LH side of fascia on bracket	86	94
Radio (Z111)	centre of fascia	86	
Radio Amplifier (Z175)	behind LH side of fascia	86	
Radio Tune Resistor (Z235)	Fascia Wire Harness near Rear Screen Wipe Switch	86	
Radio Tune Switch (X233)	top RH side of fascia near Instrument Cluster	86	136
Radio Volume Down Switch (X236)	top RH side of fascia near Instrument Cluster	86	134
Radio Volume Resistor (Z234)	Fascia Wire Harness near Heated Rear Screen Switch	86	
Radio Volume Up Switch (X235)	top RH side of fascia near Instrument Cluster	86	134
Radio Waveband Resistor (Z236)	Fascia Wire Harness near Rear Screen Wipe Switch	86	
Radio Waveband Switch (X234)	top RH side of fascia near Instrument Cluster	86	136
Rear A/C Control Relay (K194)	LH side of luggage compartment on rear A/C evaporator	82	170
Rear A/C Evaporator Temperature Switch (X260)	LH side of luggage compartment on rear A/C evaporator	82	171
Rear A/C Fan Speed Relay (K205)	LH side of luggage compartment on rear A/C evaporator	82	172
Rear A/C Illumination Relay (K204)	LH side of luggage compartment on rear A/C evaporator	82	171
Rear A/C Refrigerant Control Valve (K207)	LH side of luggage compartment on rear A/C evaporator	82	170
Rear A/C Refrigerant Control Valve Diode (Z228)	LH side of luggage compartment behind trim panel	82	170
Rear A/C Switch Amplifier (Z216)	LH side of luggage compartment on rear A/C evaporator	82	169
Rear A/C Switch Amplifier In-Line Fuse (P140)	LH side of luggage compartment behind trim panel	82	173

<b>Component</b>	<b>Location</b>	<b>Manual</b>	<b>View</b>
Rear Blower Motor (M145) . .	LH side of luggage compartment on rear A/C evaporator . . . . .	82 . . . . .	169
Rear Blower Motor Relay (K193) . . . . .	LH side of luggage compartment on rear A/C evaporator . . . . .	82 . . . . .	172
Rear Blower Resistor Unit (Z215) . . . . .	LH side of luggage compartment on rear A/C evaporator . . . . .	82	
Rear Cargo Lamp (B157) . . . .	RH rear of luggage compartment . . . . .	86	
Rear Fog Guard Lamps Switch (X154) . . . . .	top RH side of fascia near Instrument Cluster . . . . .	86 . . . . .	133
Rear Interior Roof Lamp (B124) . . . . .	centre of roof . . . . .	86 . . . . .	168
Rear Screen Wash Pump (M119) . . . . .	LH rear of engine compartment . . . . .	86 . . . . .	2
Rear Screen Wash Switch (X222) . . . . .	top RH side of fascia near Instrument Cluster . . . . .	86 . . . . .	135
Rear Screen Wipe Switch (X221) . . . . .	top RH side of fascia near Instrument Cluster . . . . .	86 . . . . .	135
Rear Sunroof Lockout Switch (X263) . . . . .	front centre of roof . . . . .	76 . . . . .	117
Rear Sunroof Motor (M144) . .	centre of roof . . . . .	76 . . . . .	119
Rear Sunroof Switch (X262) . .	front centre of roof . . . . .	76 . . . . .	118
Rear Window Isolation Switch (X187) . . . . .	in rear of centre console . . . . .	86 . . . . .	111
Rear Wiper Motor (M120) . . . .	RH side of tailgate . . . . .	84 . . . . .	181
Rear Wiper Relay (K183) . . . .	behind LH footwell trim panel . . . . .	86 . . . . .	87
Reverse Switch (X157) . . . . .	LH side of transmission . . . . .	86 . . . . .	80
Right Condenser Fan Motor (M121) . . . . .	behind front grille . . . . .	82 . . . . .	33
Right Front Door Key Switch (X202) . . . . .	in top rear of RH front door at door handle . . . . .	86 . . . . .	161
Right Front Door Lock Actuator (M122) . . . . .	in rear of RH front door . . . . .	76 . . . . .	160
Right Front Door Switch (X118) . . . . .	front of RH front door jamb . . . . .	86 . . . . .	158
Right Front Indicator Lamp (B154) . . . . .	RH front of vehicle . . . . .	86 . . . . .	26
Right Front Side Lamp (B167)	RH front of engine compartment . . . . .	86 . . . . .	27
Right Front Wheel Speed Sensor (X158) . . . . .	behind RH front wheel . . . . .	70 . . . . .	75
Right Front Window Motor (M133) . . . . .	in front of RH front door . . . . .	86 . . . . .	162
Right Front Window Switch (X151) . . . . .	in rear of centre console . . . . .	86 . . . . .	110
Right Headlamp (B130) . . . . .	RH front of engine compartment . . . . .	86 . . . . .	28

Component	Location	Manual	View
Right Headlamp Level Unit (Z155)	behind RH headlamp	86	
Right Heated Oxygen Sensor (X160)	lower RH side of engine	19	66
Right Horn (K134)	behind RH side of front grille	86	191
Right Maximum Cool Switch (X268)	behind heater and A/C control panel	82	106
Right Mirror Actuator (M123)	top front of RH front door	86	159
Right Rear Door Lock Actuator (M125)	inside front of RH rear door	76	164
Right Rear Door Switch (X163)	in lower part of RH B-post	86	163
Right Rear Indicator Lamp (B165)	RH side of rear bumper	86	190
Right Rear Lamp Assembly (B136)	RH rear of luggage compartment	86	177
Right Rear Wheel Speed Sensor (X161)	behind RH rear wheel	70	76
Right Rear Window Console Switch (X162)	in rear of centre console	86	111
Right Rear Window Door Switch (X189)	inside front of RH rear door	86	165
Right Rear Window Motor (M124)	inside front of RH rear door	86	166
Right Repeater Lamp (B137)	RH front side of vehicle	86	25
Right Tail Lamp (B156)	RH side of rear bumper	86	190
Rotary Coupler (Z119)	top of steering column	76	130
Satellite Fuse Box 1 (P127)	behind RH side of fascia on Fascia Fuse Box	86	142
Satellite Fuse Box 2 (P128)	behind RH side of fascia on Fascia Fuse Box	86	142
Saudi Junction Connector (X241)	behind RH side of fascia	86	147
Sounder Relay (K160)	behind LH footwell trim panel	86	87
Speed Trip Module (Z164)	behind LH side of fascia	19	
Starter (M134) 300Tdi with EDC	lower LH side of engine	86	8
Starter (M134) 300Tdi without EDC	lower LH side of engine	86	7
Starter (M134) MFI – T16	lower RH side of engine	86	64
Starter (M134) MFI – V8	lower RH side of engine	86	63
Starter Relay Diode (Z158)	Main Wire Harness near Starter Solenoid Relay	86	150
Starter Solenoid (K136) 300Tdi with EDC	lower LH side of engine	86	8
Starter Solenoid (K136) 300Tdi without EDC	lower LH side of engine	86	7



<b>Component</b>	<b>Location</b>	<b>Manual</b>	<b>View</b>
Starter Solenoid (K136) MFI – T16	lower RH side of engine	86	64
Starter Solenoid (K136) MFI – V8	lower RH side of engine	86	63
Starter Solenoid Relay (K137)	behind RH footwell trim panel	86	151
Steering Wheel Cruise Switches (X266)	in steering wheel	19	128
Stop Lamp Switch (X168)	behind RH side of fascia on brake pedal support	86	125
Stop Lamp Switch Sup- pressor (Z206)	behind RH side of fascia near steering column	86	125
Subwoofer (K146)	LH side of tailgate	86	184
Subwoofer Amplifier (Z176)	LH side of tailgate on Subwoofer	86	184
Sunroof Control Unit (Z162)	front centre of roof	76	116
Tailgate Lock Actuator (M132)	LH side of tailgate	76	182
Tailgate Switch (X170)	in RH side of tailgate door jamb	86	
Theft Alarm LED (B151)	centre of fascia	86	
Theft Alarm Relay (K159)	behind LH footwell trim panel	86	87
Theft Alarm Unit (Z163)	behind LH side of fascia on bracket	86	93
Throttle Position Sensor (X171) 300Tdi with EGR	RH side of engine on injector pump	19	48
Throttle Position Sensor (X171) MFI – T16	RH front of engine	19	42
Throttle Position Sensor (X171) MFI – V8	top centre front of engine	19	14
Throttle Position Sensor (X257)	behind RH side of fascia	19	123
Trailer Auxiliary Socket (X172)	RH rear of luggage compartment behind trim panel	86	178
Transfer Box Oil Temperature Switch (X174)	LH side of transfer box	86	81
Transfer Box Position Switch (X175)	top RH side of transfer box	86	84
Transfer Box Solenoid (K154)	top RH side of transfer box	86	84
Transfer Box Solenoid Diode (Z232)	Gearbox Wire Harness near C105	86	
Transmission Range Selector Switch (Z110)	beneath centre console near transmission range selector	86	109
Tune Select Resistor (K140)	behind RH side of fascia	19	122
Vehicle Speed Sensor (X190)	LH side of transfer box	86	82
Water Valve (K206)	RH rear corner of engine compartment	82	61
Window Lift ECU (Z147)	behind LH side of fascia on bracket	86	92

Connector	Location	View
C100 (3-W)	RH front of engine compartment on Engine Compartment Fuse Box	40
C101 (4-W)	RH front of engine compartment on Engine Compartment Fuse Box	40
C103 (3-B)	RH front of engine compartment on Right Headlamp	28
C104 (3-B)	LH front of engine compartment on Left Headlamp	28
C105 (13-B)	LH rear of engine compartment	1
C109 (2-W)	LH front of engine compartment on Left Front Side Lamp	27
C110 (2-W)	RH front of engine compartment on Right Front Side Lamp	27
C112 (3-W) MFI – V8	LH rear corner of engine to Left Heated Oxygen Sensor	74
C112 (4-B) MFI – T16	lower LH side of engine to Left Heated Oxygen Sensor	9
C113 (3-W)	RH rear of engine to Right Heated Oxygen Sensor	57
C114 (2-W)	RH front of engine compartment on Engine Compartment Fuse Box	40
C115 (3-W)	RH front of engine compartment on Engine Compartment Fuse Box	40
C116 (1-W)	RH front of engine compartment on Engine Compartment Fuse Box	40
C120 (2-B)	LH rear of engine compartment on Rear Screen Wash Pump	2
C123 (2-B)	RH front side of vehicle on Right Repeater Lamp	25
C124 (2-B)	LH front side of vehicle on Left Repeater Lamp	25
C125 (2-B)	LH rear corner of engine compartment to A.B.S. Hydraulic Pump	4
C127 (3-B)	RH rear corner of engine compartment on Brake Fluid Level Switch	72
C129 (13-B)	LH rear corner of engine compartment on A.B.S. Booster Unit	4
C130 (2-W)	LH rear corner of engine compartment to Left Front Wheel Speed Sensor	4
C131 (2-W)	RH side of engine compartment to Right Front Wheel Speed Sensor	60
C132 (4-B) MFI – V8	top rear of engine on Idle Air Control Valve	57
C132 (6-B) MFI – T16	RH front of engine on Idle Air Control Valve	42
C133 (5-B) 300Tdi with EDC	LH rear of engine compartment on Mass Air Flow Sensor	11
C133 (6-B) MFI – V8	LH side of engine on Mass Air Flow Sensor	10
C134 (2-B) MFI – T16	top centre front of engine on Fuel Injectors	18
C134 (2-B) MFI – V8	LH side of engine on Fuel Injectors	12
C135 (2-B) MFI – T16	top centre front of engine on Fuel Injectors	18
C135 (2-B) MFI – V8	RH side of engine on Fuel Injectors	54
C136 (2-B) MFI – T16	top centre front of engine on Fuel Injectors	18
C136 (2-B) MFI – V8	LH side of engine on Fuel Injectors	12
C137 (2-B) MFI – T16	top centre front of engine on Fuel Injectors	18
C137 (2-B) MFI – V8	RH side of engine on Fuel Injectors	54
C138 (2-B) MFI – V8	LH side of engine on Fuel Injectors	12
C139 (2-B) MFI – V8	RH side of engine on Fuel Injectors	54
C140 (2-B) MFI – V8	LH rear of engine on Fuel Injectors	5
C141 (2-B) MFI – V8	RH side of engine on Fuel Injectors	57
C142 (2-N)	lower RH side of engine on Oil Pressure Switch	35

<b>Connector</b>	<b>Location</b>	<b>View</b>
C144 (2–RU) MFI – T16 . . . . .	RH rear corner of engine compartment on Evaporative Emission Canister Purge Valve . . . . .	68
C144 (2–RU) MFI – V8 . . . . .	RH side of engine compartment on Evaporative Emission Canister Purge Valve . . . . .	67
C145 (2–W) 300Tdi with EDC	RH side of engine to Compressor Clutch . . . . .	50
C145 (2–W) 300Tdi without EDC . . . . .	RH side of engine to Compressor Clutch . . . . .	49
C145 (2–W) MFI – T16 . . . . .	RH side of engine to Compressor Clutch	
C145 (2–W) MFI – V8 . . . . .	RH side of engine to Compressor Clutch . . . . .	41
C146 (2–B) 300Tdi with EDC	RH front of engine on Condenser Fan Coolant Temperature Switch . . . .	44
C146 (2–B) 300Tdi without EDC . . . . .	RH front of engine on Condenser Fan Coolant Temperature Switch . . . .	46
C146 (2–B) MFI – V8 . . . . .	top centre front of engine on Condenser Fan Coolant Temperature Switch . . . . .	55
C148 (3–B) . . . . .	top centre front of engine on Ignition Control Module . . . . .	17
C149 (3–B) MFI – T16 . . . . .	RH front of engine on Throttle Position Sensor . . . . .	42
C149 (3–B) MFI – V8 . . . . .	top centre front of engine to Throttle Position Sensor . . . . .	14
C150 (2–S) MFI – T16 . . . . .	RH side of engine on Engine Fuel Temperature Sensor . . . . .	43
C150 (2–U) MFI – V8 . . . . .	top centre front of engine on Engine Fuel Temperature Sensor . . . . .	13
C152 (2–N) 300Tdi with EDC	top centre front of engine on Engine Coolant Temperature Sensor . . . .	20
C152 (2–N) 300Tdi without EDC . . . . .	top centre front of engine on Engine Coolant Temperature Sensor . . . .	19
C152 (2–N) MFI – T16 . . . . .	LH front of engine on Engine Coolant Temperature Sensor . . . . .	15
C152 (2–N) MFI – V8 . . . . .	top centre front of engine on Engine Coolant Temperature Sensor . . . .	13
C153 (1–B) . . . . .	LH front corner of engine compartment on Ignition Coil . . . . .	30
C154 (1–B) . . . . .	LH front corner of engine compartment on Ignition Coil . . . . .	30
C155 (1–B) . . . . .	LH front corner of engine compartment on Ignition Coil . . . . .	30
C156 (1–B) . . . . .	LH front corner of engine compartment on Ignition Coil . . . . .	30
C159 (6–B) . . . . .	RH front of engine compartment on Glow Plug Timer Unit . . . . .	39
C160 (3–B) . . . . .	RH side of engine to Throttle Position Sensor . . . . .	59
C161 (1–W) 300Tdi without EGR . . . . .	RH side of engine to Compressor Clutch . . . . .	47
C162 (2–B) . . . . .	RH front of engine on Compressor Clutch Cut–out Switch . . . . .	45
C164 (3–B) . . . . .	LH side of engine on EGR Valve Position Sensor . . . . .	7
C165 (2–B) . . . . .	LH front of engine compartment on EGR Control Solenoid . . . . .	23
C166 (2–B) 300Tdi . . . . .	LH front of engine compartment . . . . .	23
C166 (2–B) MFI – V8 MFI – T16 . . . . .	LH front of engine compartment . . . . .	22
C167 (3–B) . . . . .	LH front corner of engine compartment on Cruise Control Vacuum Pump . . . . .	21
C168 (2–B) . . . . .	behind LH side of front grille on Left Horn . . . . .	191
C169 (2–B) . . . . .	behind RH side of front grille on Right Horn . . . . .	191

Connector	Location	View
C170 (2-R)	LH rear of engine compartment on Front Screen Wash Pump	2
C171 (3-B)	LH rear of engine compartment on Inertia Fuel Shut-Off Switch	1
C173 (2-B)	LH rear of engine compartment on Headlamp Wash Pump	2
C177 (2-B)	LH rear of engine compartment to Dim/Dip Resistor	3
C178 (2-B) 300Tdi	RH front of engine compartment to Alarm Bonnet Switch	39
C178 (2-B) MFI – V8 MFI – T16	RH front of engine compartment to Alarm Bonnet Switch	37
C179 (2-U)	RH rear corner of engine compartment on Water Valve	61
C181 (2-S)	RH rear corner of engine compartment on A/C Dual Pressure Switch	70
C182 (2-B)	behind front grille to Right Condenser Fan Motor	33
C183 (2-B)	behind front grille to Left Condenser Fan Motor	32
C190 (3-B)	behind LH headlamp on Left Headlamp Level Unit	28
C191 (3-B)	behind RH headlamp on Right Headlamp Level Unit	28
C195 (4-W)	RH rear corner of engine compartment	71
C196 (2-NU)	RH rear of engine to Injector Needle Lift Sensor	62
C197 (3-B)	RH rear of engine to Engine Speed Sensor	62
C198 (3-W) 300Tdi with EDC	RH side of engine to Fuel Injector Assembly	53
C198 (6-B) MFI – T16	top rear of engine to Fuel Injectors	61
C199 (8-W)	RH side of engine to Fuel Pump Assembly	52
C200 (4-W)	behind RH side of fascia near steering column	127
C201 (7-W)	top of steering column on Main Lighting Switch	129
C202 (24-W)	behind RH side of fascia near steering column	127
C203 (7-W)	behind RH side of fascia on Fascia Fuse Box	145
C204 (24-W)	behind RH side of fascia on Fascia Fuse Box	146
C205 (24-B)	behind RH side of fascia on Multi-Function Unit (MFU)	145
C206 (4-W)	behind RH side of fascia on Fascia Fuse Box	147
C207 (10-B)	on Instrument Cluster	139
C208 (18-W)	behind RH side of fascia on Fascia Fuse Box	144
C209 (24-W)	behind RH side of fascia left of steering column	120
C211 (10-W)	behind RH side of fascia on Fascia Fuse Box	146
C212 (14-W)	behind LH side of fascia	91
C214 (3-B)	top RH side of fascia on Instrument Illumination Rheostat	
C215 (24-Y)	behind RH side of fascia left of steering column	120
C216 (7-N)	behind RH side of fascia right of heater evaporator unit	121
C217 (20-W)	behind RH side of fascia right of heater evaporator unit	121
C218 (8-W)	behind LH side of fascia on bracket	94
C219 (4-W)	behind RH side of fascia on Fascia Fuse Box	144
C220 (3-N)	behind RH side of fascia to Ignition Switch	127
C221 (10-W)	on Instrument Cluster	141

<b>Connector</b>	<b>Location</b>	<b>View</b>
C222 (10-W) .....	on Instrument Cluster .....	139
C223 (5-U) .....	on Instrument Cluster .....	139
C224 (6-W) .....	behind RH side of fascia to Front Wiper Motor	
C225 (16-B) Except Japan ..	behind LH side of fascia on Theft Alarm Unit .....	93
C225 (16-B) Japan .....	behind LH side of fascia on Central Locking Control Unit .....	93
C226 (3-W) .....	behind RH side of fascia on Fascia Fuse Box .....	147
C227 (4-B) .....	behind RH side of fascia on Stop Lamp Switch .....	125
C228 (8-W) .....	behind RH side of fascia on Mirror Adjustment Switch	
C229 (1-W) .....	behind RH side of fascia on Fascia Fuse Box .....	145
C230 (8-S) .....	centre of fascia on Radio	
C238 (5-Y) MFI – T16 .....	behind RH footwell trim panel on Cooling Fan Relay .....	150
C238 (9-B) MFI – V8 .....	behind RH footwell trim panel on Fan Control Module .....	154
C239 (5-U) .....	behind RH footwell trim panel on Engine Control Load Relay .....	153
C240 (5-Y) .....	behind RH footwell trim panel on Fuel Pump Relay .....	153
C241 (5-Y) .....	behind RH footwell trim panel on Compressor Clutch Relay .....	154
C242 (5-B) .....	behind RH footwell trim panel on A/C Logic Relay .....	155
C243 (40-B) MFI – V8 .....	behind RH side of fascia on Engine Control Module (ECM) .....	156
C243 (55-B) 300Tdi with EDC .....	behind RH side of fascia on Engine Control Module (ECM) .....	156
C244 (5-W) MFI – V8 .....	behind RH side of fascia Data Link Connectors .....	156
C245 (4-W) 300Tdi with EDC	behind RH side of fascia Data Link Connectors .....	156
C245 (5-W) MFI – V8 .....	behind RH side of fascia Data Link Connectors .....	156
C246 (2-U) .....	behind RH side of fascia on Tune Select Resistor .....	122
C247 (16-B) .....	behind RH side of fascia on EGR Valve Control Module .....	157
C248 (3-W) .....	behind RH side of fascia Data Link Connector (EGR) .....	157
C249 (5-G) .....	top RH side of fascia on Rear Screen Wash Switch .....	135
C250 (5-W) .....	top RH side of fascia on Rear Screen Wipe Switch .....	135
C252 (6-R) .....	behind RH side of fascia near steering column .....	120
C254 (1-W) .....	behind RH side of fascia on Fascia Fuse Box .....	144
C255 (1-B) .....	on Instrument Cluster .....	139
C259 (6-W) .....	behind RH side of fascia on Headlamp Level Switch .....	143
C260 (10-K) .....	centre of fascia on Radio	
C262 (5-U) .....	centre of fascia on Cruise Control Switch	
C263 (5-U) .....	top RH side of fascia on Rear Fog Guard Lamps Switch .....	133
C264 (5-U) .....	top RH side of fascia on Heated Rear Screen Switch .....	133
C267 (10-B) .....	centre of fascia on Hazard Switch	
C268 (8-N) .....	centre of fascia on Radio	
C269 (2- ) .....	centre of fascia on Theft Alarm LED	
C270 (4-B) .....	centre of fascia on Clock	

Connector	Location	View
C274 (6-W) Except Japan . . .	behind LH side of fascia on Theft Alarm Unit . . . . .	93
C274 (6-W) Japan . . . . .	behind LH side of fascia on Central Locking Control Unit . . . . .	93
C277 (23-W) . . . . .	behind LH side of fascia . . . . .	91
C279 (5-N) . . . . .	behind LH footwell trim panel on Theft Alarm Relay . . . . .	87
C280 (5-W) . . . . .	behind LH footwell trim panel on Sounder Relay . . . . .	87
C281 (5-G) . . . . .	behind LH footwell trim panel on Rear Wiper Relay . . . . .	87
C282 (5-Y) . . . . .	behind LH footwell trim panel on Accessory Relay . . . . .	86
C283 (5-Y) . . . . .	behind LH footwell trim panel on Horn Relay . . . . .	86
C284 (15-B) . . . . .	behind LH side of fascia on Cruise Control ECU . . . . .	90
C285 (4-W) . . . . .	behind LH side of fascia on Catalyst Warning ECU 1 . . . . .	89
C286 (4-W) . . . . .	behind LH side of fascia on Catalyst Warning ECU 2 . . . . .	88
C287 (10-W) . . . . .	behind LH side of fascia on Window Lift ECU . . . . .	92
C288 (8-W) . . . . .	behind LH side of fascia on Window Lift ECU . . . . .	92
C292 (5-Y) . . . . .	behind LH side of fascia on Condenser Fan Relay . . . . .	95
C293 (5-U) . . . . .	behind LH side of fascia on Dim/Dip Relay . . . . .	95
C298 (3-W) . . . . .	behind LH side of fascia . . . . .	99
C299 (5-Y) . . . . .	behind LH side of fascia on Catalyst Warning Relay	
C301 (6-W) . . . . .	beneath centre console . . . . .	113
C306 (3-W) . . . . .	beneath centre console . . . . .	113
C312 (35-B) . . . . .	behind LH side of fascia on Anti-Lock Brake System ECU . . . . .	97
C313 (5-U) . . . . .	behind RH side of fascia A.B.S. Diagnostic Connector	
C323 (5-B) . . . . .	LH side of transmission to Park/Neutral Position Switch . . . . .	78
C336 (3-W) . . . . .	behind RH footwell trim panel . . . . .	150
C337 (7-G) . . . . .	in rear of centre console on Left Front Window Switch . . . . .	110
C338 (7-W) . . . . .	in rear of centre console on Right Front Window Switch . . . . .	110
C339 (7-Y) . . . . .	in rear of centre console on Left Rear Window Console Switch . . . . .	111
C340 (7-R) . . . . .	in rear of centre console on Right Rear Window Console Switch . . . . .	111
C343 (7-N) . . . . .	in rear of centre console on Rear Window Isolation Switch . . . . .	111
C344 (6-B) . . . . .	beneath centre console to Transmission Range Selector Switch . . . . .	109
C346 (2-U) . . . . .	beneath centre console to Automatic Gear Selector Illumination . . . . .	109
C350 (5-G) . . . . .	behind LH side of fascia on A.B.S. Warning Relay . . . . .	96
C351 (5-Y) . . . . .	behind LH side of fascia on A.B.S. Load Relay . . . . .	96
C352 (5-B) . . . . .	behind LH side of fascia on A.B.S. Pump Relay . . . . .	96
C353 (2-W) . . . . .	beneath centre console on Fascia Cigar Lighter . . . . .	108
C354 (2-W) . . . . .	beneath RH rear of vehicle to Left Rear Wheel Speed Sensor . . . . .	187
C355 (2-W) . . . . .	beneath LH rear of vehicle to Right Rear Wheel Speed Sensor . . . . .	186
C356 (1-B) . . . . .	beneath centre console on Fascia Cigar Lighter . . . . .	108
C368 (3-B) . . . . .	top RH side of transfer box to Transfer Box Position Switch . . . . .	84
C369 (2-B) . . . . .	top RH side of transfer box to Transfer Box Solenoid . . . . .	84

<b>Connector</b>	<b>Location</b>	<b>View</b>
C370 (3-B)	LH side of transfer box on Vehicle Speed Sensor	82
C371 (2-B)	LH side of transfer box on Transfer Box Oil Temperature Switch	81
C372 (2-W)	on top of transmission	79
C378 (2-B)	beneath centre console to Driver's Seat Buckle Switch	108
C381 (3- )	beneath LH front seat on CD Changer	
C382 (8-W)	front centre of roof on Sunroof Control Unit	116
C383 (10-W)	front centre of roof on Sunroof Control Unit	116
C384 (7-G)	front centre of roof on Front Sunroof Switch	117
C385 (7-W)	front centre of roof on Rear Sunroof Switch	118
C386 (5-S)	front centre of roof on Rear Sunroof Lockout Switch	117
C387 (4-W)	front centre of roof to Front Sunroof Motor	116
C388 (4-W)	centre of roof to Rear Sunroof Motor	119
C389 (3-W)	centre of roof on Passenger's Rear Sunroof Switch	119
C391 (5-W)	centre of roof on Passenger's Rear Fan Speed Switch	167
C392 (5-U)	centre of roof on Passenger's Rear A/C Switch	167
C400 (7-B)	RH rear of luggage compartment Trailer Auxiliary Socket	178
C402 (1-B)	LH side of tailgate to Number Plate Lamps	183
C403 (6-W)	LH side of luggage compartment on Left Rear Lamp Assembly	173
C404 (1-B)	LH side of tailgate to Number Plate Lamps	183
C406 (6-W)	RH rear of luggage compartment on Right Rear Lamp Assembly	177
C407 (3-B)	beneath LH rear of vehicle	185
C408 (4-W)	RH side of tailgate to Rear Wiper Motor	181
C410 (3-W)	front centre of roof on Front Interior Roof Lamp	115
C411 (4-B)	centre of roof to Right Front Door Lamp	168
C412 (6-W)	LH side of tailgate on Subwoofer Amplifier	184
C413 (4-W)	LH side of tailgate on Subwoofer Amplifier	184
C414 (2-W)	LH side of tailgate to Tailgate Lock Actuator	182
C415 (8-W)	in RH side of tailgate door jamb	179
C424 (1-B)	RH rear of luggage compartment Trailer Auxiliary Socket	178
C425 (1-B)	RH rear of luggage compartment Trailer Auxiliary Socket	178
C434 (4-B)	top of fuel tank to Fuel Pump Module	188
C437 (6-W)	in RH side of tailgate door jamb	179
C438 (2-W)	in RH side of tailgate door jamb	179
C441 (2-R)	behind LH side of rear bumper on Left Tail Lamp	189
C442 (2-B)	behind LH side of rear bumper on Left Rear Indicator Lamp	189
C444 (2-B)	behind RH side of rear bumper on Right Tail Lamp	190
C445 (2-R)	behind RH side of rear bumper on Right Rear Indicator Lamp	190
C447 (2-W)	LH side of luggage compartment	174
C448 (16-W)	LH side of luggage compartment	174

Connector	Location	View
C453 (1-B)	LH side of tailgate	183
C454 (1-B)	RH side of tailgate to Rear Screen	180
C455 (1-B)	RH side of tailgate	180
C456 (1-B)	LH side of tailgate	183
C457 (5-W)	LH side of luggage compartment on Rear Blower Motor Relay	172
C458 (2-B)	LH side of luggage compartment on Rear Blower Motor	169
C459 (4-B)	LH side of luggage compartment on Rear Blower Resistor Unit	
C462 (2-B)	LH side of luggage compartment on Rear A/C Switch Amplifier In-Line Fuse	173
C463 (4-W)	LH side of luggage compartment on Rear A/C Control Relay	170
C464 (2-S)	LH side of luggage compartment on Rear A/C Refrigerant Control Valve	170
C465 (4-W)	LH side of luggage compartment on Rear A/C Illumination Relay	171
C466 (4-W)	LH side of luggage compartment on Rear A/C Fan Speed Relay	172
C467 (6-W)	LH side of luggage compartment on Rear A/C Switch Amplifier	169
C483 (4-B)	front centre of roof on Alarm Sensor	115
C500 (2-B)	in front of LH front door to Left Front Window Motor	162
C501 (2-W)	behind LH footwell trim panel	85
C502 (13-W)	behind LH footwell trim panel	85
C503 (6-W)	top front of LH front door to Left Mirror Actuator	159
C504 (4-W)	in top rear of LH front door to Left Front Door Key Switch	161
C507 (2-W) Japan	in rear of LH front door to Left Front Door Lock Actuator	160
C507 (4-W) Except Japan Without Theft Alarm	in rear of LH front door to Left Front Door Lock Actuator	160
C507 (6-W) Except Japan With Theft Alarm	in rear of LH front door to Left Front Door Lock Actuator	160
C510 (2-W)	behind LH footwell trim panel	85
C600 (2-B)	in front of RH front door to Right Front Window Motor	162
C601 (2-W)	behind RH footwell trim panel	148
C602 (13-W)	behind RH footwell trim panel	148
C603 (6-W)	top front of RH front door to Right Mirror Actuator	159
C604 (4-W)	in top rear of RH front door to Right Front Door Key Switch	161
C607 (4-W) Except Japan Without Theft Alarm	in rear of RH front door to Right Front Door Lock Actuator	160
C607 (6-W) Except Japan With Theft Alarm	in rear of RH front door to Right Front Door Lock Actuator	160
C610 (2-W)	behind RH footwell trim panel	148
C700 (3-W)	in lower part of LH B-post	163
C701 (2-W)	in lower part of LH B-post	163
C703 (3-B)	inside front of LH rear door to Left Rear Window Motor	166
C706 (2-W)	inside front of LH rear door to Left Rear Door Lock Actuator	164



<b>Connector</b>	<b>Location</b>	<b>View</b>
C709 (5-W) .....	inside front of LH rear door on Left Rear Window Door Switch .....	165
C800 (3-W) .....	in lower part of LH B-post .....	163
C801 (2-W) .....	in lower part of LH B-post .....	163
C803 (3-B) .....	inside front of RH rear door to Right Rear Window Motor .....	166
C806 (2-W) .....	inside front of RH rear door to Right Rear Door Lock Actuator .....	164
C809 (5-W) .....	inside front of RH rear door on Right Rear Window Door Switch .....	165
C1000 (2-G) 300Tdi with EDC .....	top centre front of engine on Boost Pressure Air Temperature Sensor ..	20
C1000 (2-G) MFI – T16 .....	RH rear of engine on Intake Air Temperature Sensor	
C1001 (3-B) .....	LH rear of engine compartment on Boost Pressure Sensor .....	11
C1002 (3-B) .....	top rear of engine on Ignition Coil 1	
C1003 (3-B) .....	top rear of engine on Ignition Coil 2	
C1004 (2-U) .....	lower RH rear of engine to Crankshaft Position Sensor .....	65
C1005 (2-W) .....	RH side of engine on Knock Sensor .....	43
C1006 (3-W) .....	RH rear corner of engine compartment Data Link Connectors .....	68
C1007 (36-B) .....	RH rear corner of engine compartment on Engine Control Module (ECM) .....	69
C1008 (18-B) .....	RH rear corner of engine compartment on Engine Control Module (ECM) .....	69
C1009 (2-B) .....	LH front of vehicle on Left Front Indicator Lamp .....	26
C1010 (2-B) .....	RH front of vehicle on Right Front Indicator Lamp .....	26
C1011 (2-W) MFI – T16 with Air Conditioning .....	front of engine compartment to Cooling Fan Motor 1	
C1011 (2-W) MFI – T16 without Air Conditioning .....	front of engine compartment to Cooling Fan Motor 1 .....	31
C1012 (2-W) .....	front of engine compartment to Cooling Fan Motor 2	
C1015 (4-W) .....	RH rear corner of engine compartment to Throttle Position Sensor .....	71
C1016 (2-B) .....	lower LH front of engine compartment on Automatic Transmission Oil Temperature Switch .....	24
C1018 (1-W) .....	LH front corner of engine compartment on Ignition Coil .....	30
C2000 (5-Y) .....	behind LH side of fascia on Interlock Relay 1	
C2001 (5- ) .....	behind LH side of fascia on Interlock Relay 2	
C2005 (2-W) .....	behind RH side of fascia on Brake Switch Vent Valve .....	126
C2006 (5-Y) .....	behind RH footwell trim panel on Starter Solenoid Relay .....	151
C2007 (5-Y) .....	behind RH footwell trim panel on Ignition Load Relay .....	151
C2008 (5-G) .....	behind RH footwell trim panel on Front Wiper Relay .....	152
C2009 (4-W) .....	top of steering column on Direction Indicator Switch .....	129
C2010 (6-W) .....	top of steering column to Rotary Coupler .....	130
C2011 (6-W) .....	top of steering column on Front Wipe/Wash Switch .....	138
C2012 (8-W) .....	top of steering column .....	131
C2013 (4-B) .....	top of steering column .....	137

Connector	Location	View
C2014 (2-B)	top of steering column on Ignition Key Lock Solenoid	132
C2015 (8-W)	top of steering column on Front Wipe/Wash Switch	138
C2016 (1-W)	behind RH side of fascia on Fascia Fuse Box	144
C2020 (29-R)	beneath centre console on Air Bag Diagnostic Control Module	112
C2021 (5- ) Manual Transmission	behind LH side of fascia on Speed Trip Module	
C2021 (5- ) Automatic Transmission	behind LH side of fascia on Cruise Control Lockout Relay	
C2022 (5-W)	behind heater and A/C control panel on Front Fan Speed Switch	105
C2023 (4-W)	behind heater and A/C control panel	106
C2024 (5-W)	behind heater and A/C control panel on Main Rear A/C Switch	107
C2025 (5-W)	behind heater and A/C control panel on Front A/C Switch	105
C2026 (5-B)	behind heater and A/C control panel on Air Supply Selector Switch	107
C2027 (5-W)	behind LH side of fascia LH side of heater evaporator unit	102
C2028 (6-W)	behind RH footwell trim panel on E200	152
C2029 (6-W)	behind LH footwell trim panel on E201	85
C2031 (6-W)	beneath centre console on E303	114
C2035 (2-B)	behind RH side of fascia on Clutch Pedal Position Switch	
C2036 (7-B)	in steering wheel to Rotary Coupler	128
C2051 (8-B)	behind RH footwell trim panel on Multi-Function Relay Unit	149
C2052 (6-B)	behind RH footwell trim panel on Multi-Function Relay Unit	149
C2053 (5-Y)	behind LH side of fascia on Power Amplifier Relay	
C2054 (18- )	behind LH side of fascia on Radio Amplifier	
C2055 (13-W)	behind RH side of fascia left of steering column	120
C2056 (5-U)	top RH side of fascia on Radio Tune Switch	136
C2057 (5-U)	top RH side of fascia on Radio Waveband Switch	136
C2058 (5-W)	top RH side of fascia on Radio Volume Up Switch	134
C2059 (5-G)	top RH side of fascia on Radio Volume Down Switch	134
C2060 (5- )	centre of fascia on Radio	
C2061 (7- )	centre of fascia on Radio	
C2062 (1-B)	behind RH side of fascia Saudi Junction Connector	147
C2063 (2-B)	behind RH side of fascia to Stop Lamp Switch Suppressor	125
C2064 (2-W)	behind LH side of fascia on Catalyst Warning ECU 1	89
C2065 (2-W)	behind LH side of fascia on Catalyst Warning ECU 2	88
C2066 (8-W)	behind LH side of fascia LH side of heater evaporator unit	101
C2067 (10-W)	behind LH side of fascia LH side of heater evaporator unit	102
C2068 (5-W)	behind LH side of fascia on Front Blower Motor Relay	98
C2069 (2-B)	behind LH side of fascia on Front Blower Motor	99
C2070 (4-B)	behind LH side of fascia on Front Blower Resistor Unit	103

<b>Connector</b>	<b>Location</b>	<b>View</b>
C2071 (2-B) .....	behind LH side of fascia on Air Recirculation Solenoid In-Line Fuse .....	98
C2072 (4-Y) .....	behind LH side of fascia on Air Recirculation Solenoid .....	91
C2073 (10-W) .....	behind RH side of fascia right of heater evaporator unit .....	121
C2074 (5-Y) .....	behind LH side of fascia on Power Wash Relay .....	94
C2075 (3-W) .....	behind RH side of fascia on EDC Stop Lamp Switch .....	124
C2079 (2- ) .....	centre of fascia on Radio	
C3000 (1-B) .....	on top of transmission to Reverse Switch .....	79
C3001 (1-B) .....	on top of transmission to Reverse Switch .....	79
<b>Ground</b>	<b>Location</b>	<b>View</b>
E100 300Tdi .....	RH front of engine compartment behind battery .....	38
E100 MFI – V8 MFI – T16 ...	RH front of engine compartment behind battery .....	36
E101 300Tdi .....	LH front of engine compartment on fender well .....	23
E101 MFI – V8 MFI – T16 ...	LH front of engine compartment on fender well .....	22
E103 300Tdi .....	RH front of engine compartment behind battery .....	38
E103 MFI – T16 .....	RH front of engine compartment behind battery .....	36
E103 MFI – V8 .....	LH rear corner of engine below valve cover .....	6
E104 .....	lower RH rear of engine compartment on frame rail	
E105 .....	lower LH front of engine compartment	
E106 .....	lower LH rear of engine	
E107 .....	mounted on bonnet (hood)	
E108 .....	near Starter	
E109 .....	LH rear corner of engine	
E110 .....	RH side of bulkhead .....	73
E200 .....	behind RH footwell trim panel .....	152
E201 .....	behind LH footwell trim panel .....	85
E203 .....	behind LH side of fascia .....	97
E204 .....	behind LH footwell trim panel .....	85
E303 .....	beneath centre console .....	114
E400 .....	LH side of luggage compartment .....	175
E401 .....	RH rear of luggage compartment .....	176
E402 .....	RH side of tailgate .....	181
<b>Splice</b>	<b>Location</b>	<b>View</b>
HJ1 (20-W) .....	behind LH side of fascia .....	101
HJ2 (20-U) .....	behind LH side of fascia .....	100
HJ3 (20-W) .....	behind LH side of fascia .....	100
HJ4 (20-W) .....	behind LH side of fascia .....	101
HJ5 (20-W) .....	behind LH side of fascia .....	101
HJ6 (20-G) .....	behind LH side of fascia .....	101
HJ7 (20-U) .....	behind RH side of fascia .....	122

<b>Splice</b>	<b>Location</b>	<b>View</b>
HJ8 (20-S) .....	behind instrument cluster .....	141
HJ9 (20-S) .....	behind instrument cluster .....	140
HJ10 (20-B) .....	behind RH footwell trim panel .....	148
HJ11 (20-W) .....	behind LH side of fascia .....	100

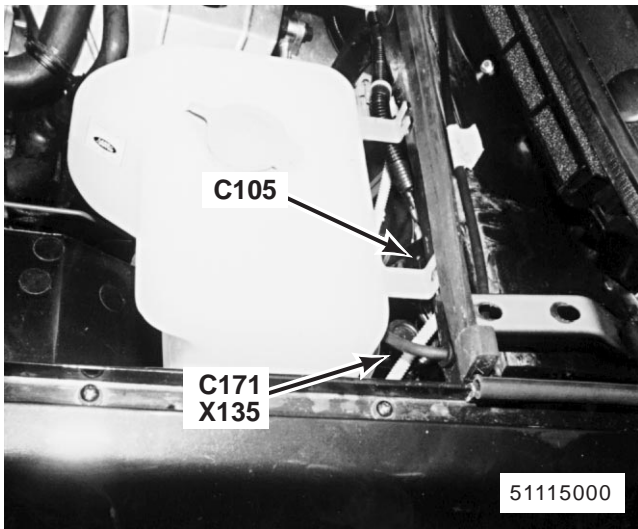

1. LH rear of engine compartment  
 X135 Inertia Fuel Shut-Off Switch  
 C105 (13-B)  
 C171 (3-B)



2. LH rear of engine compartment  
 M105 Front Screen Wash Pump  
 M110 Headlamp Wash Pump  
 M119 Rear Screen Wash Pump  
 C120 (2-B)  
 C170 (2-R)  
 C173 (2-B)

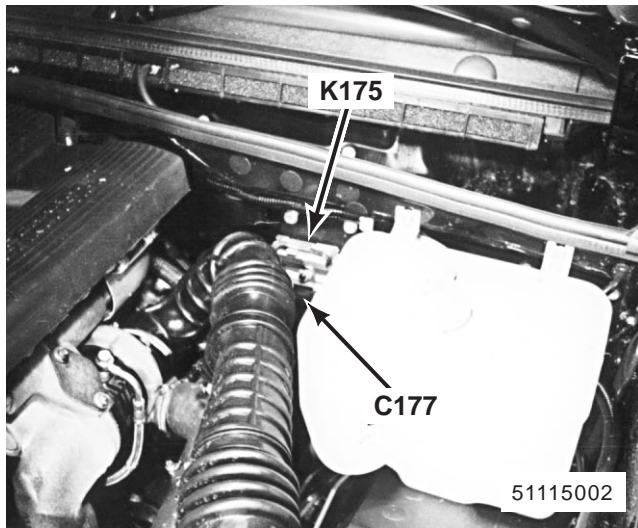

3. LH rear of engine compartment  
 K175 Dim/Dip Resistor  
 C177 (2-B)

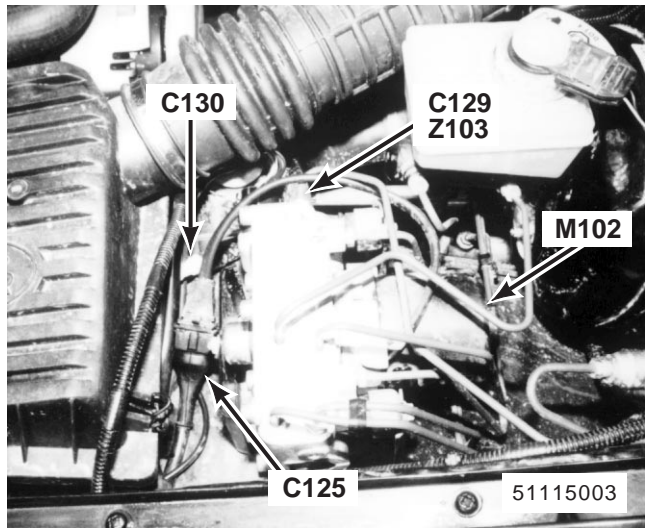

4. LH rear corner of engine compartment  
 M102 A.B.S. Hydraulic Pump  
 Z103 A.B.S. Booster Unit  
 C125 (2-B)  
 C129 (13-B)  
 C130 (2-W)

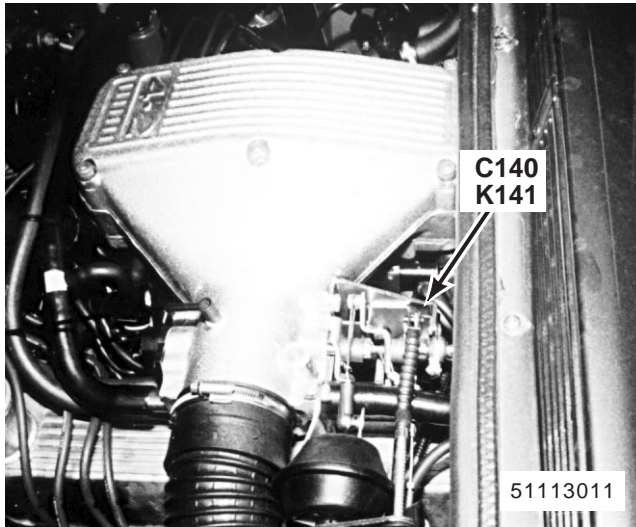

5. LH rear of engine MFI-V8  
K141 Fuel Injectors  
C140 (2-B)

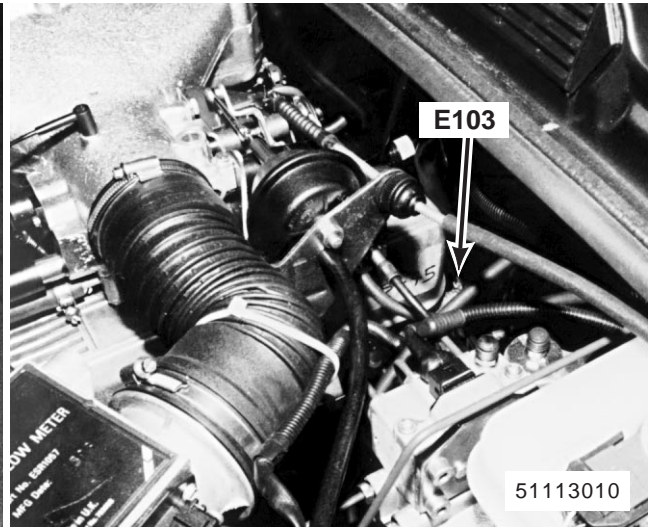

6. LH rear of engine MFI-V8  
E103

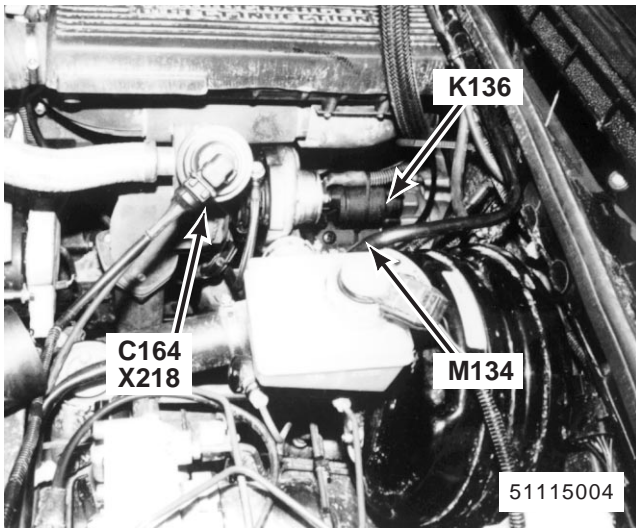

7. lower LH side of engine 300Tdi without EDC  
K136 Starter Solenoid  
M134 Starter  
X218 EGR Valve Position Sensor  
C164 (3-B)

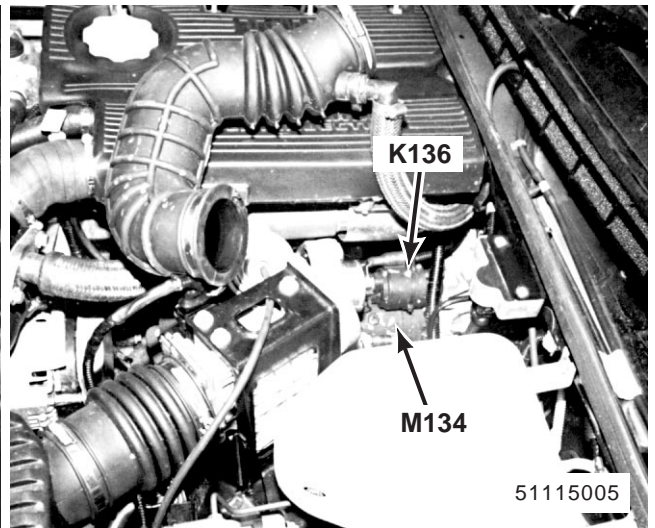

8. lower LH side of engine 300Tdi with EDC  
K136 Starter Solenoid  
M134 Starter



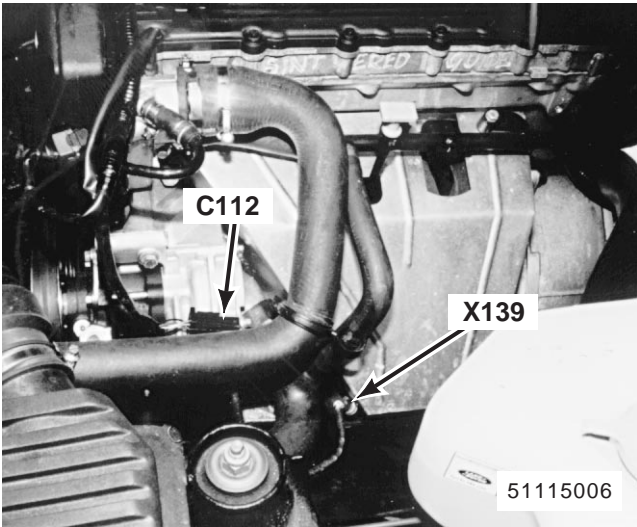

9. lower LH side of engine MFI-T16  
X139 Left Heated Oxygen Sensor  
C112 (4-B)

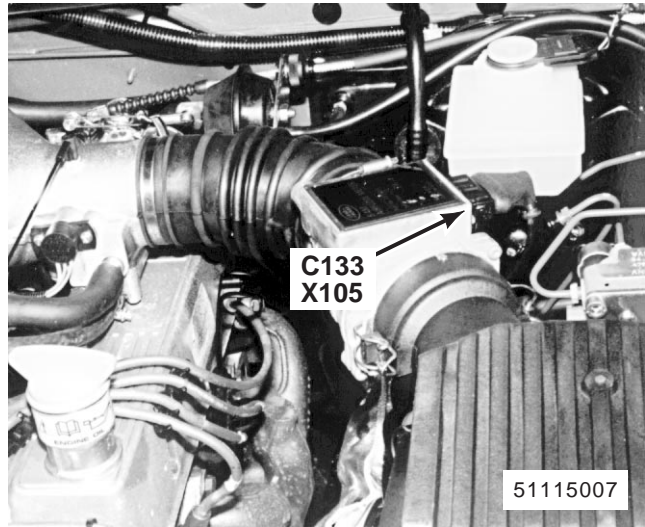

10. LH side of engine MFI-V8  
X105 Mass Air Flow Sensor  
C133 (6-B)

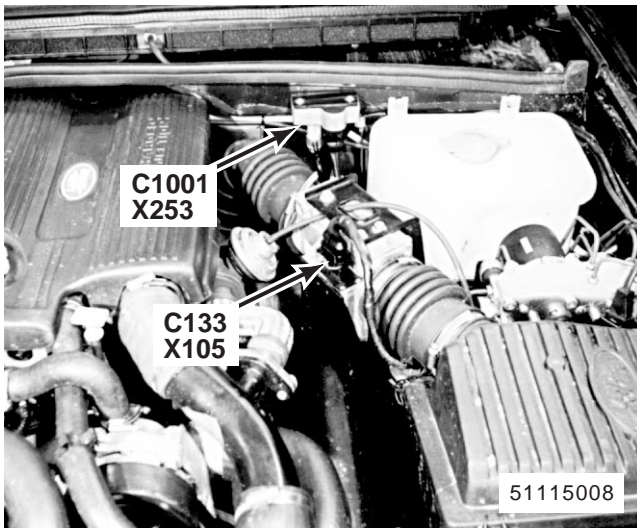

11. LH rear of engine compartment 300Tdi with EDC  
X105 Mass Air Flow Sensor  
X253 Boost Pressure Sensor  
C133 (5-B)  
C1001 (3-B)

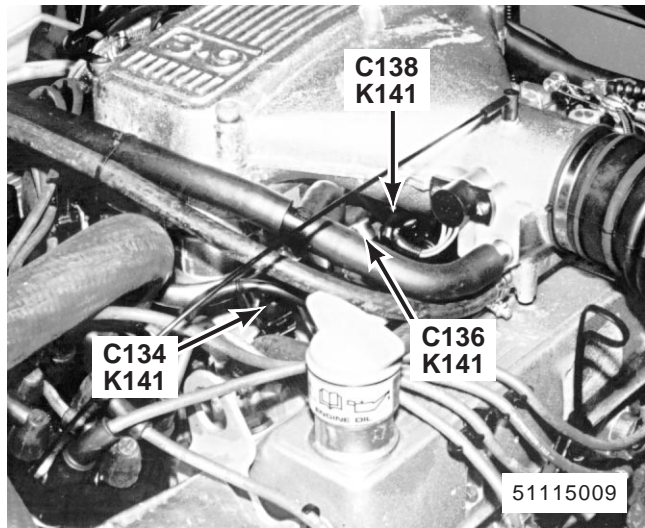

12. LH side of engine MFI-V8  
K141 Fuel Injectors  
C134 (2-B)  
C136 (2-B)  
C138 (2-B)

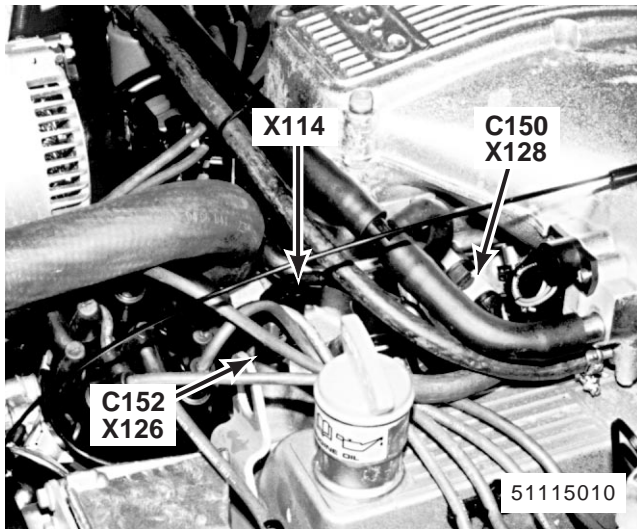

13. LH side of engine MFI-V8  
 X114 Engine Coolant Temperature Gauge Sensor  
 X126 Engine Coolant Temperature Sensor  
 X128 Engine Fuel Temperature Sensor  
 C150 (2-U)  
 C152 (2-N)

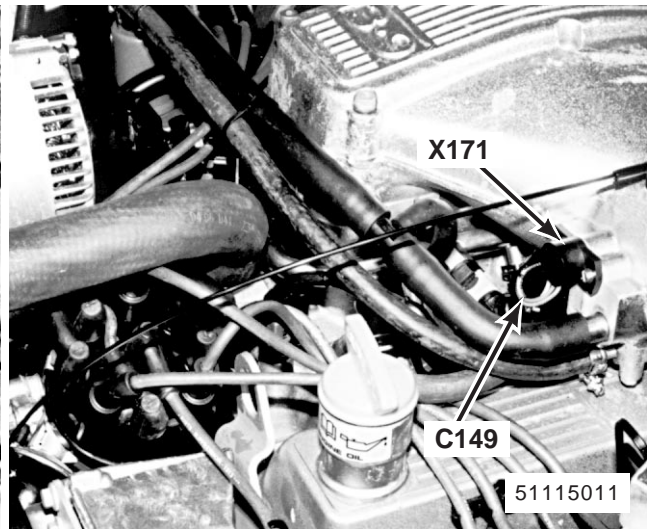

14. LH side of engine MFI-V8  
 X171 Throttle Position Sensor  
 C149 (3-B)

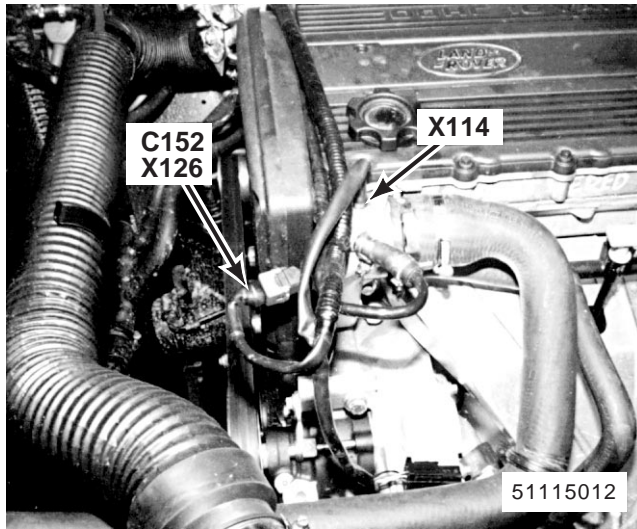

15. LH front of engine MFI-T16  
 X114 Engine Coolant Temperature Gauge Sensor  
 X126 Engine Coolant Temperature Sensor  
 C152 (2-N)

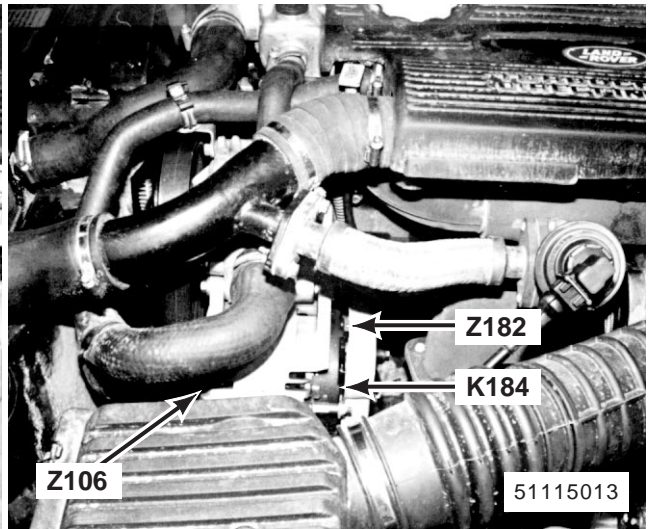

16. lower LH side of engine 300Tdi  
 K184 Phase Tap Resistor  
 Z106 Generator  
 Z182 Generator Suppression Capacitor



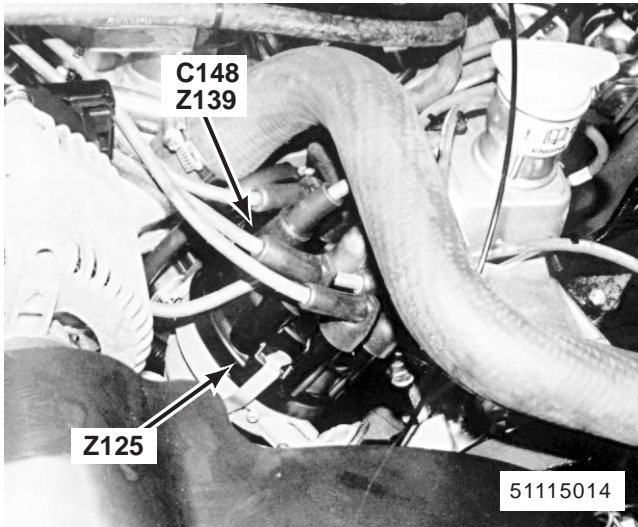

17. top centre front of engine MFI-V8  
Z125 Distributor  
Z139 Ignition Control Module  
C148 (3-B)

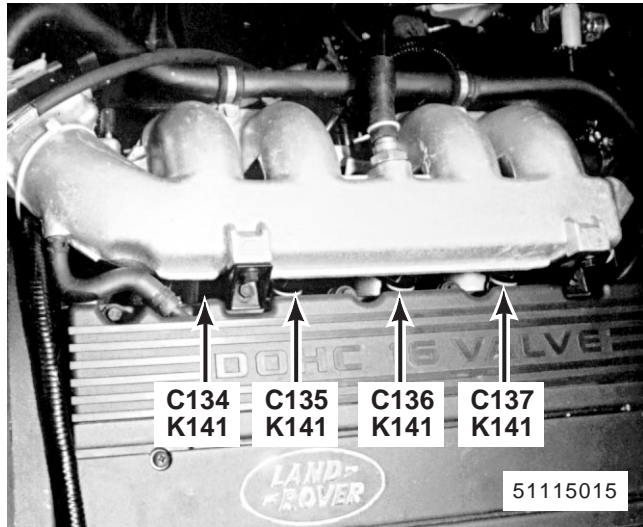

18. top centre front of engine MFI-T16  
K141 Fuel Injectors  
C134 (2-B)  
C135 (2-B)  
C136 (2-B)  
C137 (2-B)

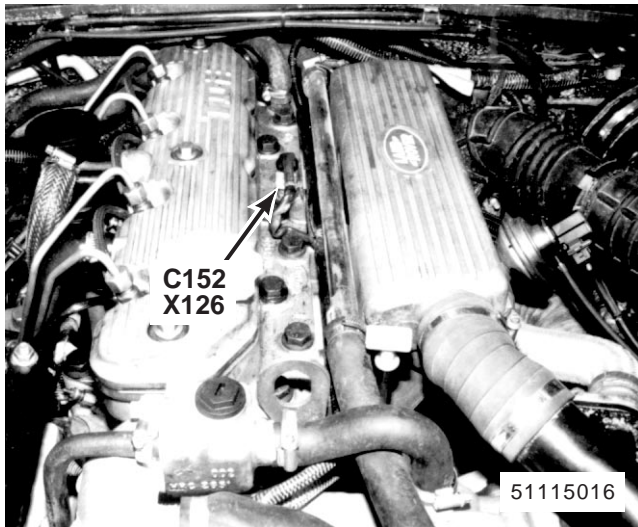

19. top centre front of engine 300Tdi without EDC  
X126 Engine Coolant Temperature Sensor  
C152 (2-N)

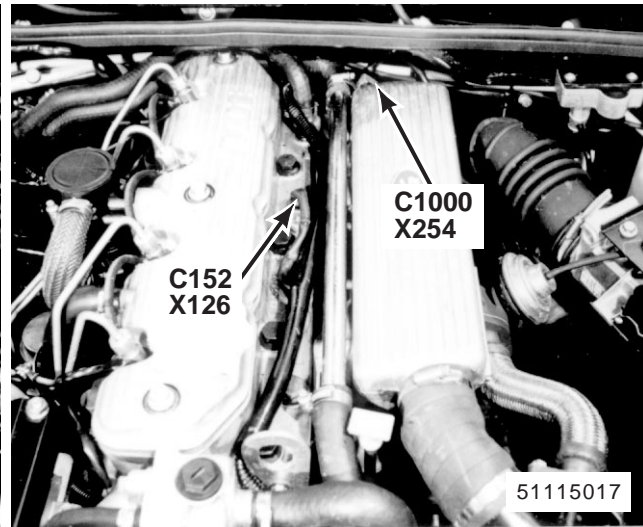

20. top centre front of engine 300Tdi with EDC  
X126 Engine Coolant Temperature Sensor  
X254 Boost Pressure Air Temperature Sensor  
C152 (2-N)  
C1000 (2-G)

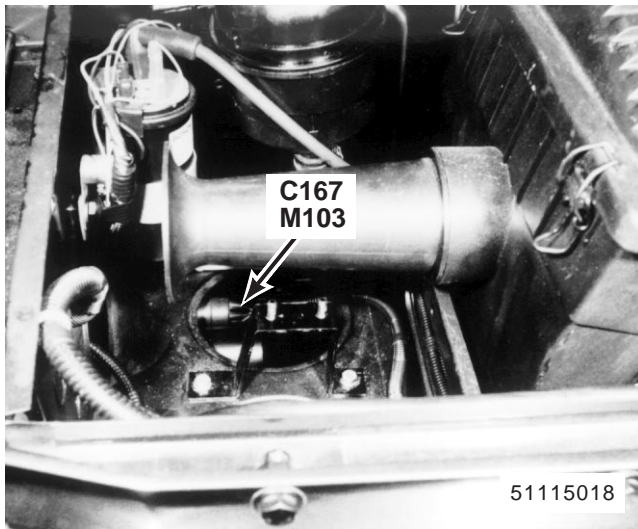

21. LH front corner of engine compartment (MFI-V8 shown; others similar)  
M103 Cruise Control Vacuum Pump  
C167 (3-B)

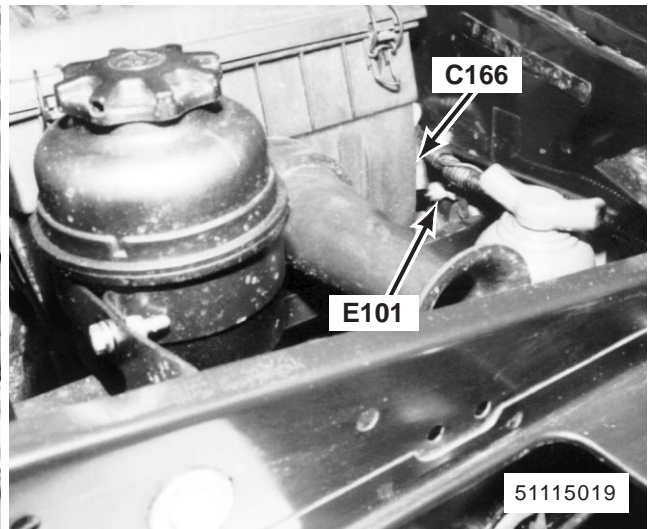

22. LH front of engine compartment MFI-V8  
MFI-T16  
C166 (2-B)  
E101

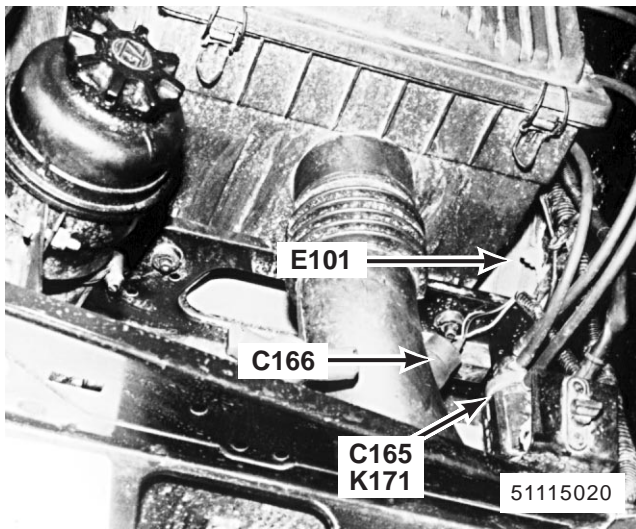

23. LH front of engine compartment 300Tdi  
K171 EGR Control Solenoid  
C165 (2-B)  
C166 (2-B)  
E101

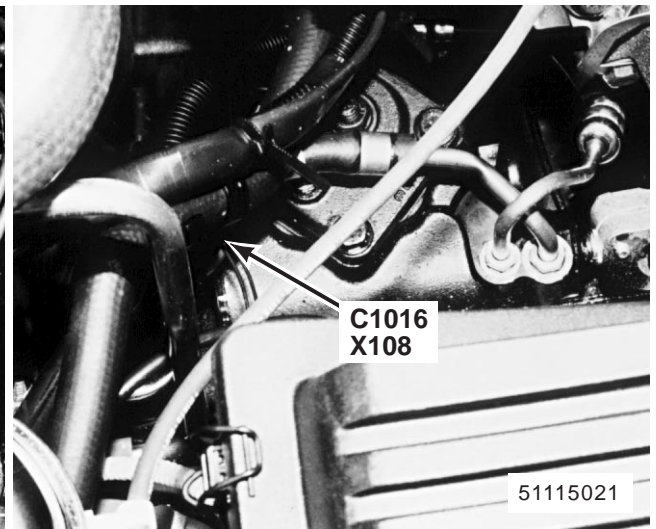

24. lower LH front of engine compartment (MFI-V8 shown; others similar)  
X108 Automatic Transmission Oil Temperature Switch  
C1016 (2-B)





25. LH front side of vehicle (RH similar)  
 B122 Left Repeater Lamp  
 B137 Right Repeater Lamp  
 C123 (2-B) (Right)  
 C124 (2-B) (Left)

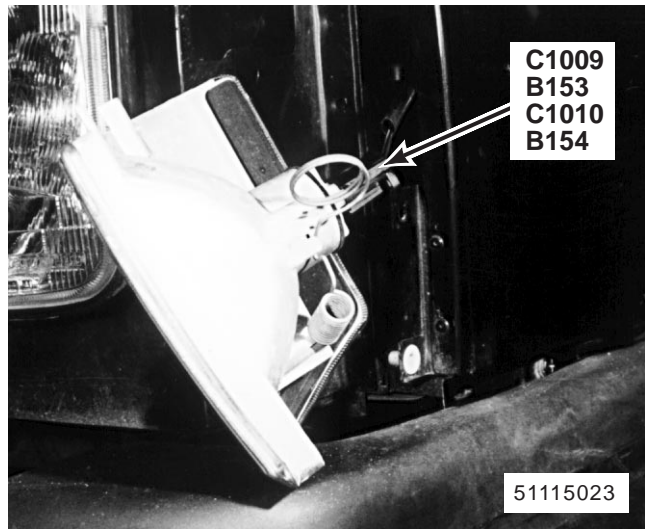

26. LH front of vehicle (RH similar)  
 B153 Left Front Indicator Lamp  
 B154 Right Front Indicator Lamp  
 C1009 (2-B) (Left)  
 C1010 (2-B) (Right)

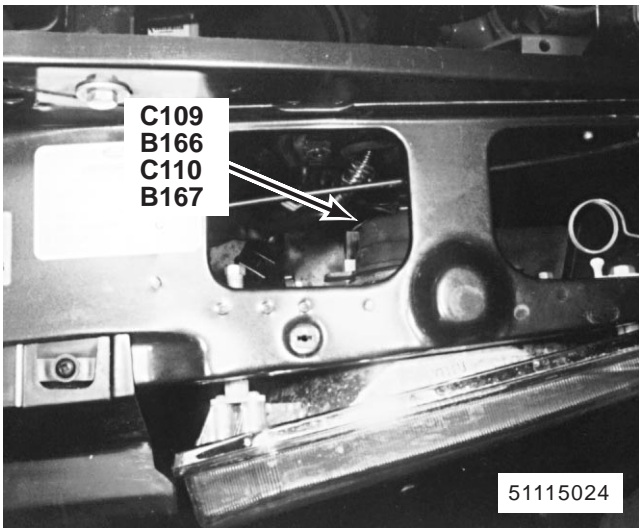

27. LH front of engine compartment (RH similar)  
 B166 Left Front Side Lamp  
 B167 Right Front Side Lamp  
 C109 (2-W) (Left)  
 C110 (2-W) (Right)

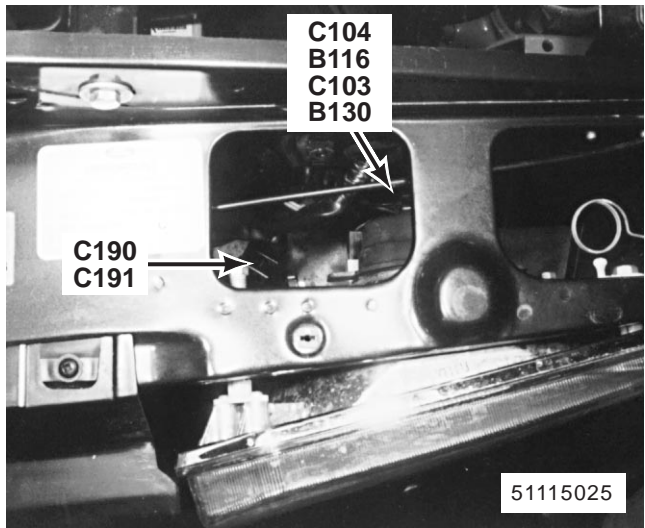

28. LH front of engine compartment (RH similar)  
 B116 Left Headlamp  
 B130 Right Headlamp  
 C103 (3-B) (Right)  
 C104 (3-B) (Left)  
 C190 (3-B) (Left)  
 C191 (3-B) (Right)

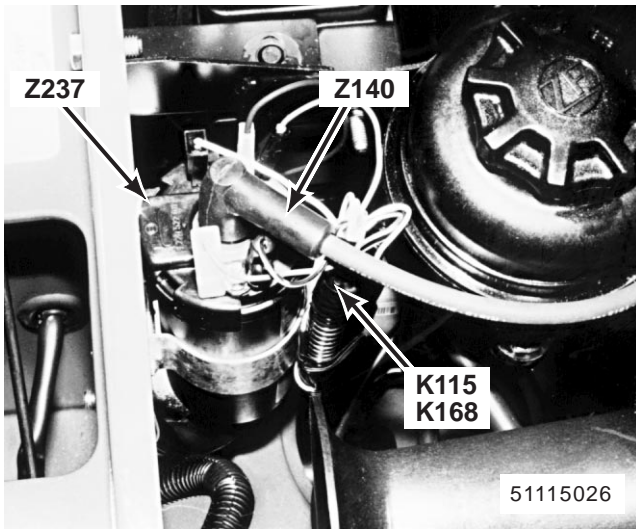

29. LH front corner of engine compartment MFI-V8

- K115 Multiport Fuel Injection Ignition Resistor 1
- K168 Multiport Fuel Injection Ignition Resistor 2
- Z140 Ignition Coil
- Z237 Ignition Coil Noise Suppressor

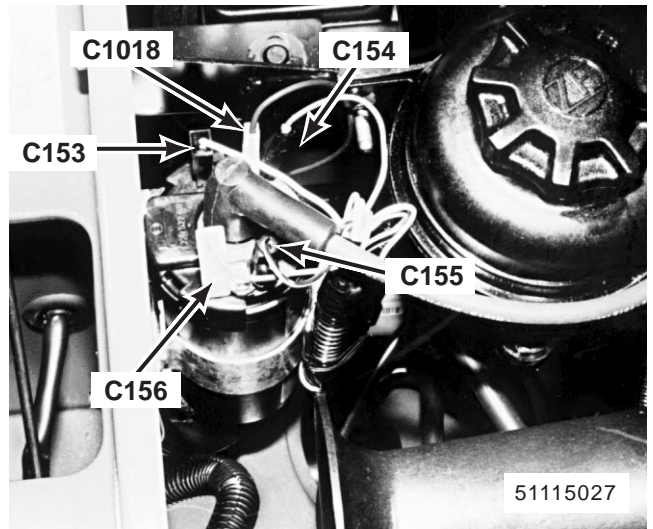

30. LH front corner of engine compartment MFI-V8

- C153 (1-B)
- C154 (1-B)
- C155 (1-B)
- C156 (1-W)
- C1018 (1-W)

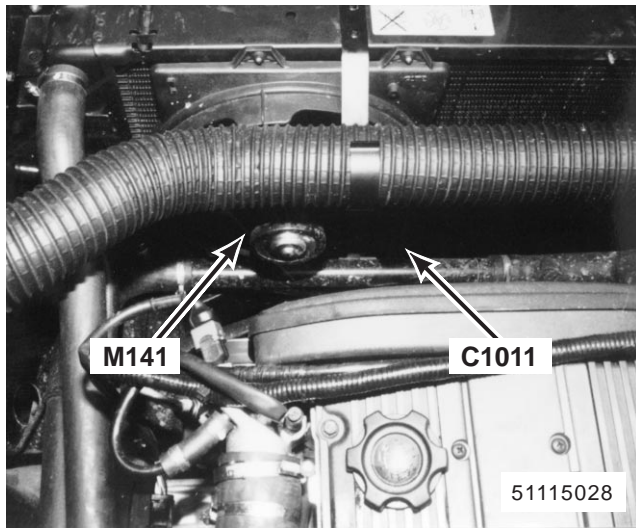

31. front of engine compartment MFI-T16 without Air Conditioning

- M141 Cooling Fan Motor 1
- C1011 (2-W)

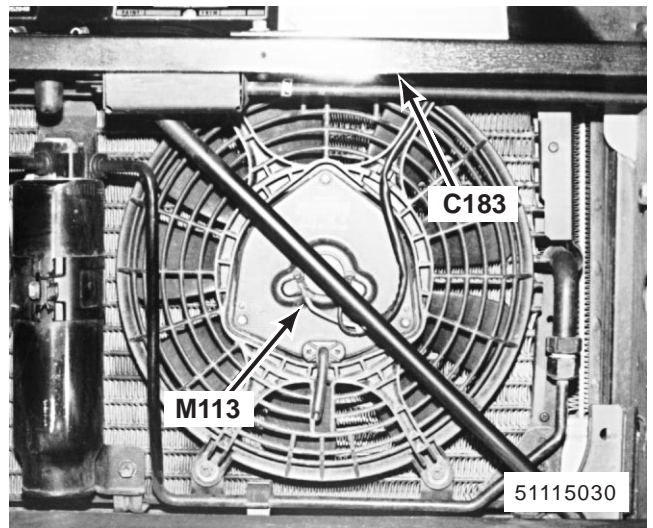

32. behind front grille

- M113 Left Condenser Fan Motor
- C183 (2-B)



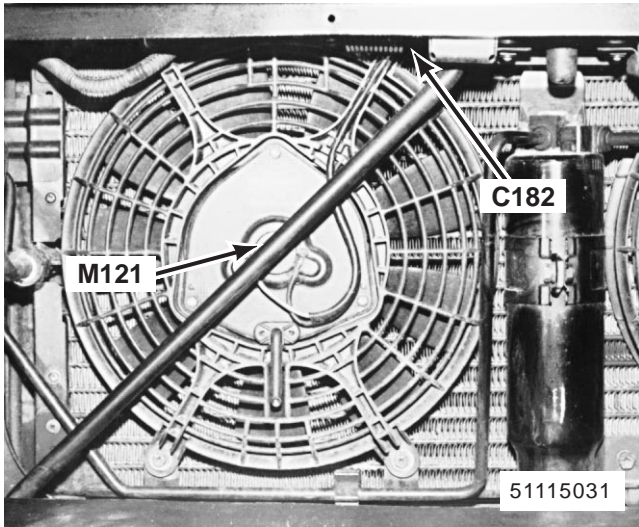

33. behind front grille  
M121 Right Condenser Fan Motor  
C182 (2-B)

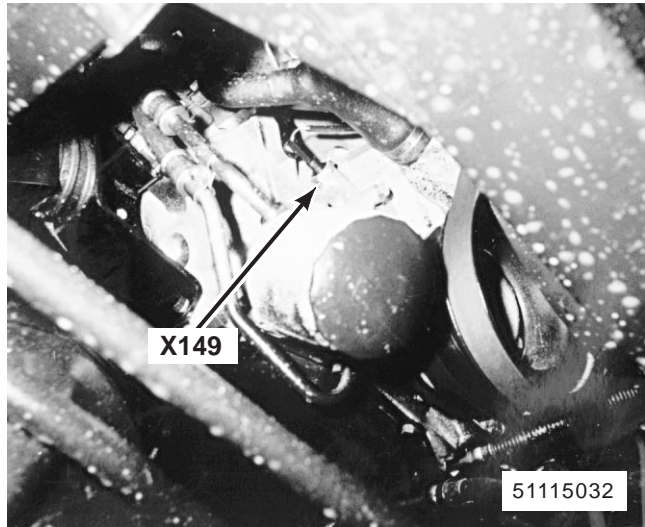

34. lower RH side of engine MFI-V8  
X149 Oil Pressure Switch



35. lower RH side of engine MFI-T16  
X149 Oil Pressure Switch  
C142 (2-N)

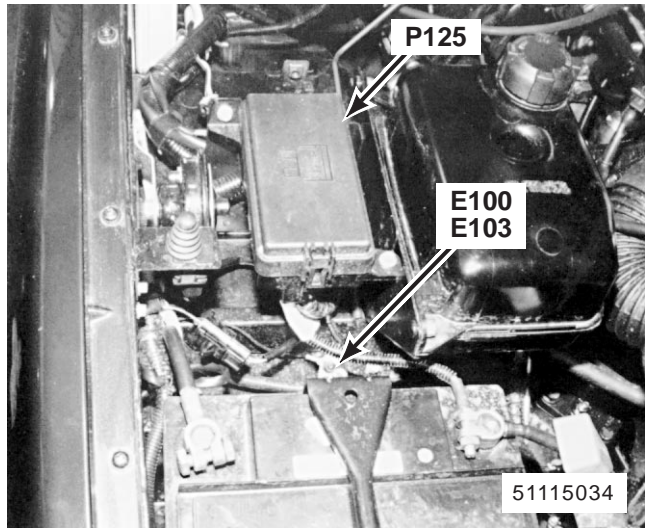

36. RH front of engine compartment MFI-V8  
MFI-T16  
P125 Engine Compartment Fuse Box  
E100  
E103 MFI-T16

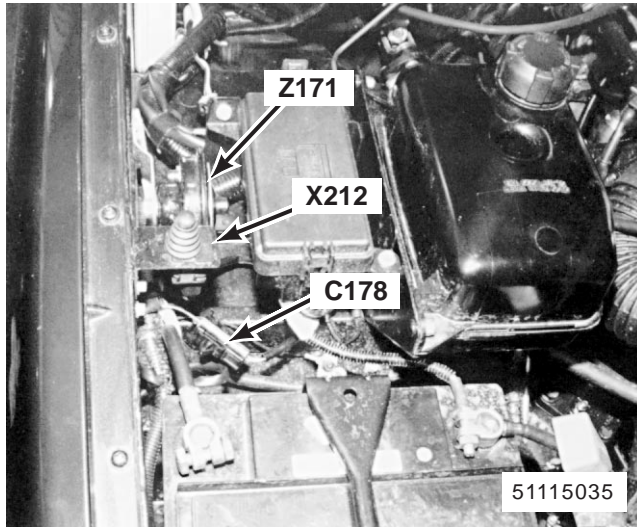

37. RH front of engine compartment MFI-V8  
MFI-T16  
X212 Alarm Bonnet Switch  
Z171 Alarm Sounder  
C178 (2-B)

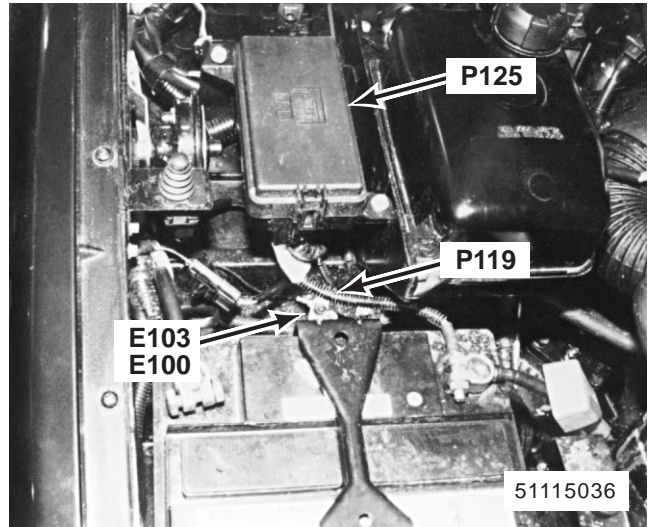

38. RH front of engine compartment 300Tdi  
P119 Fusible Link  
P125 Engine Compartment Fuse Box  
E100  
E103

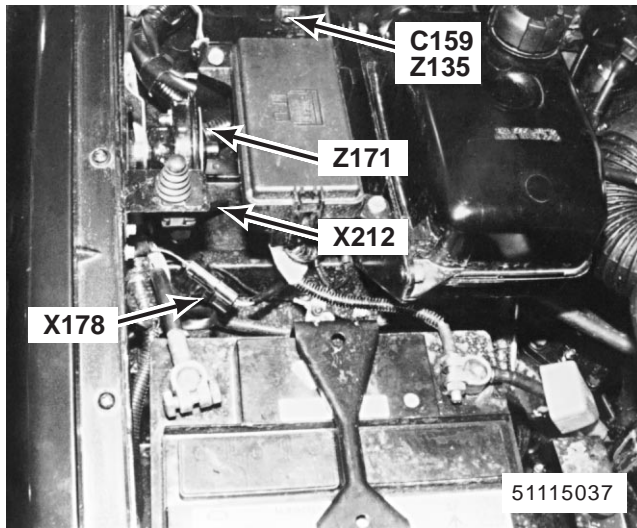

39. RH front of engine compartment 300Tdi  
X212 Alarm Bonnet Switch  
Z135 Glow Plug Timer Unit  
Z171 Alarm Sounder  
C159 (6-B)  
C178 (2-B)

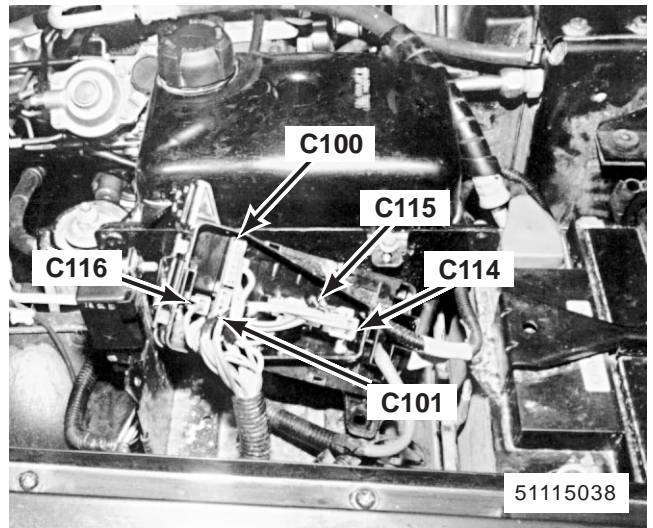

40. RH front of engine compartment  
C100 (3-W)  
C114 (2-W)  
C115 (3-W)  
C116 (1-W)  
C101 (4-W)



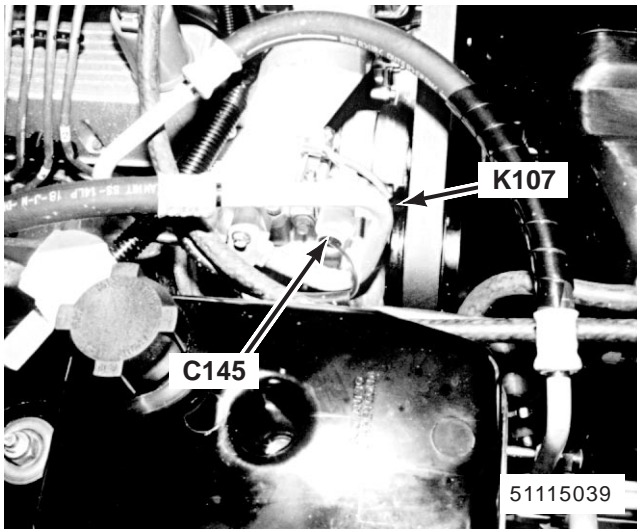

41. RH side of engine MFI-V8  
K107 Compressor Clutch  
C145 (2-W)

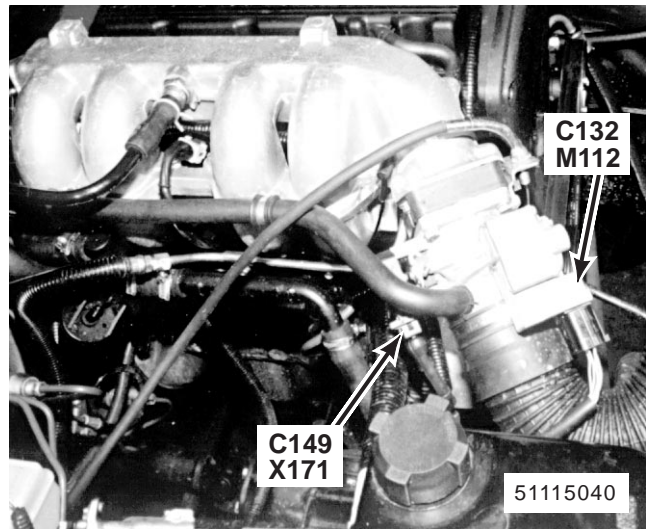

42. RH front of engine MFI-T16  
M112 Idle Air Control Valve  
X171 Throttle Position Sensor  
C132 (6-B)  
C149 (3-B)

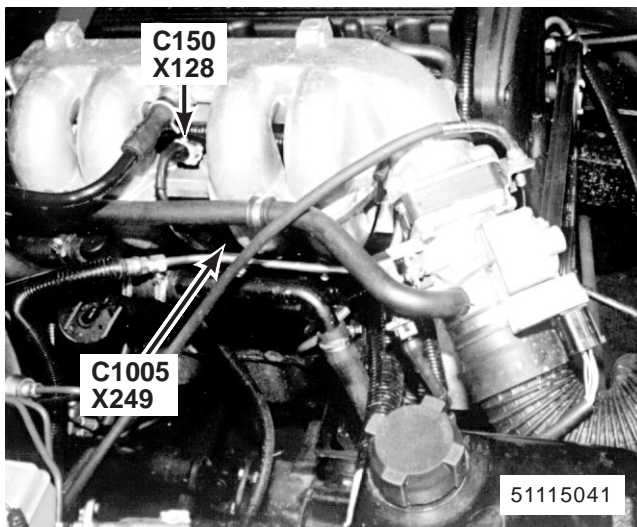

43. RH side of engine MFI-T16  
X128 Engine Fuel Temperature Sensor  
X249 Knock Sensor  
C150 (2-S)  
C1005 (2-W)

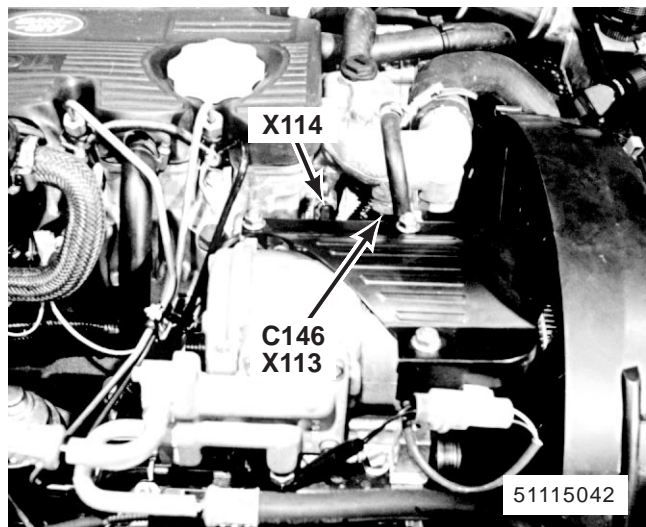

44. RH front of engine 300Tdi with EDC  
X113 Condenser Fan Coolant Temperature Switch  
X114 Engine Coolant Temperature Gauge Sensor  
C146 (2-B)

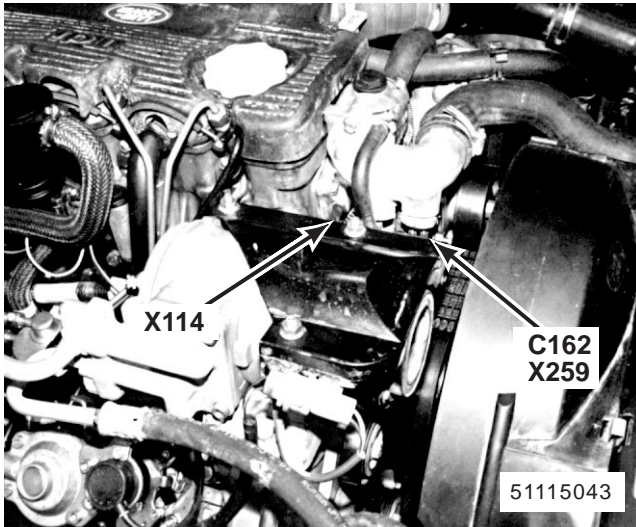

45. RH front of engine 300Tdi without EDC  
 X114 Engine Coolant Temperature Gauge Sensor  
 X259 Compressor Clutch Cut-out Switch  
 C162 (2-B)

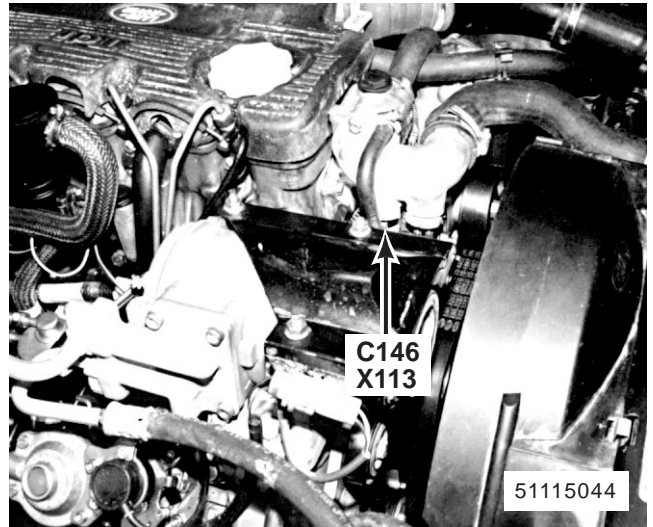

46. RH front of engine 300Tdi without EDC  
 X113 Condenser Fan Coolant Temperature Switch  
 C146 (2-B)

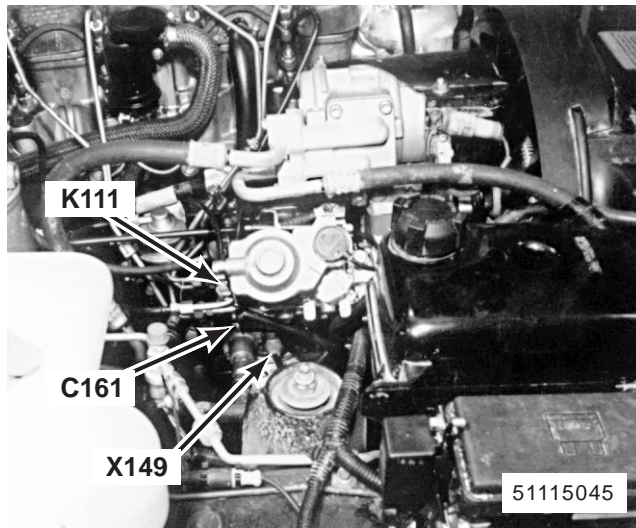

47. RH side of engine 300Tdi without EGR  
 K111 Fuel Shut-Off Solenoid  
 X149 Oil Pressure Switch  
 C161 (1-W)

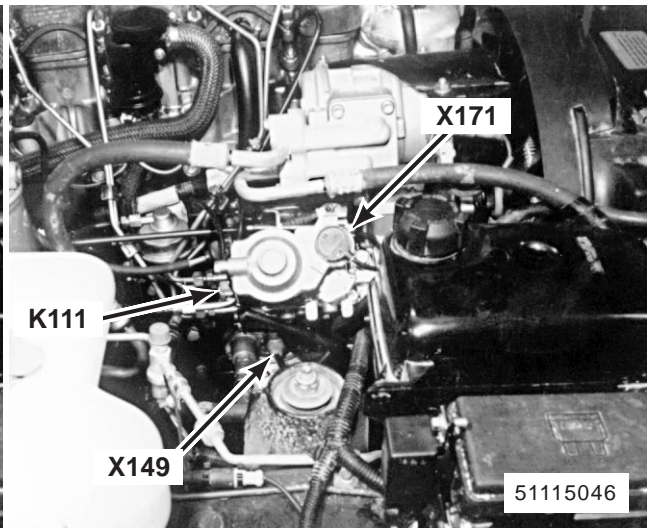

48. RH side of engine 300Tdi with EGR  
 K111 Fuel Shut-Off Solenoid  
 X149 Oil Pressure Switch  
 X171 Throttle Position Sensor



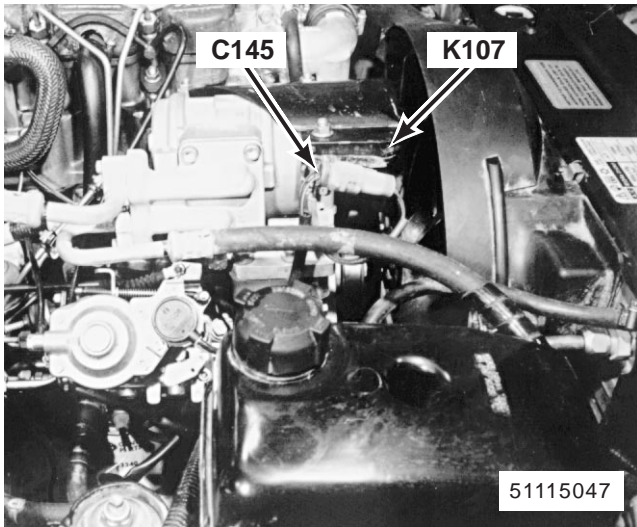

49. RH side of engine 300Tdi without EDC  
K107 Compressor Clutch  
C145 (2-W)

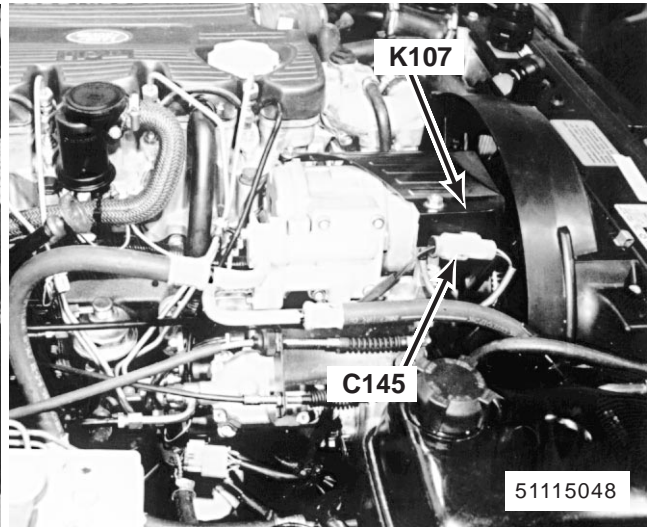

50. RH side of engine 300Tdi with EDC  
K107 Compressor Clutch  
C145 (2-W)

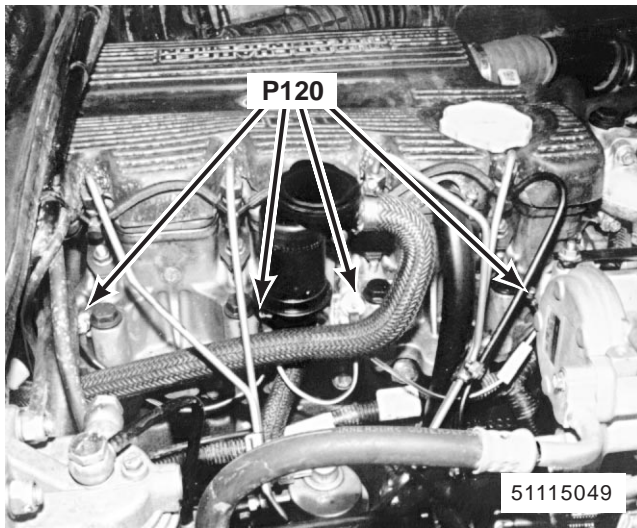

51. RH side of engine 300Tdi  
P120 Glow Plugs

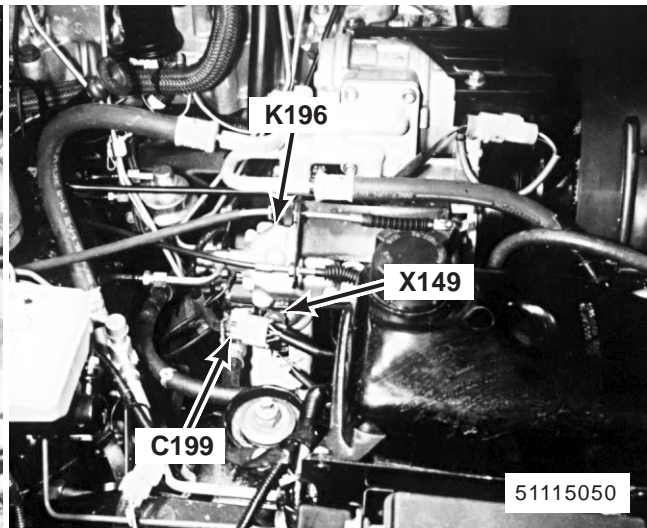

52. RH side of engine 300Tdi with EDC  
K196 Fuel Pump Assembly  
X149 Oil Pressure Switch  
C199 (8-W)

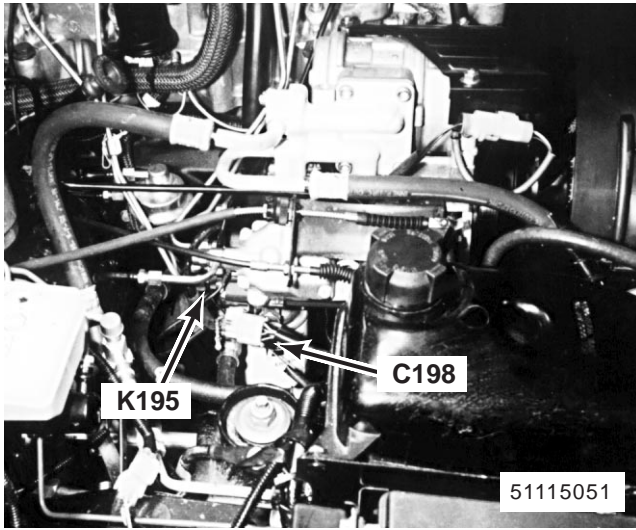

53. RH side of engine 300Tdi with EDC  
K195 Fuel Injector Assembly  
C198 (3-W)

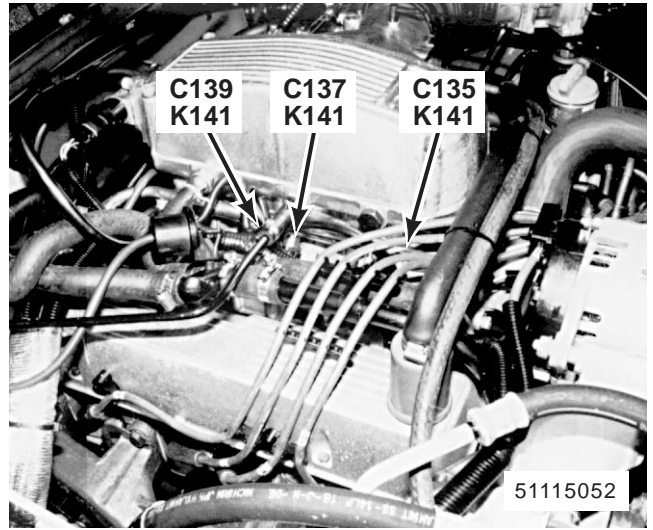

54. RH side of engine MFI-V8  
K141 Fuel Injectors  
C135 (2-B)  
C137 (2-B)  
C139 (2-B)

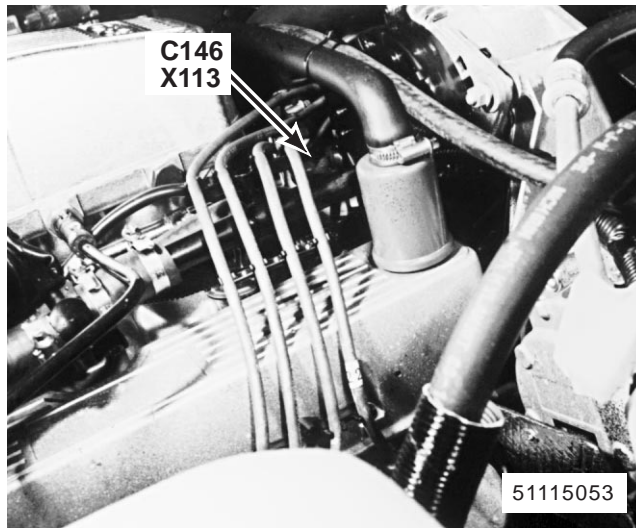

55. RH front of engine MFI-V8  
X113 Condenser Fan Coolant Temperature Switch  
C146 (2-B)

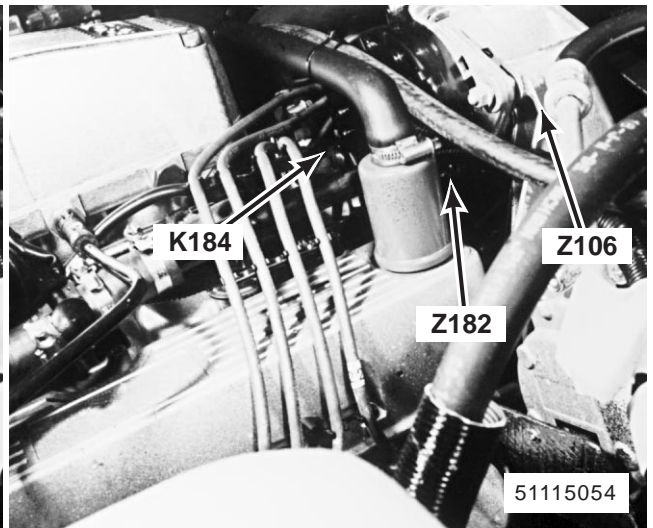

56. RH front of engine MFI-V8  
K184 Phase Tap Resistor  
Z106 Generator  
Z182 Generator Suppression Capacitor



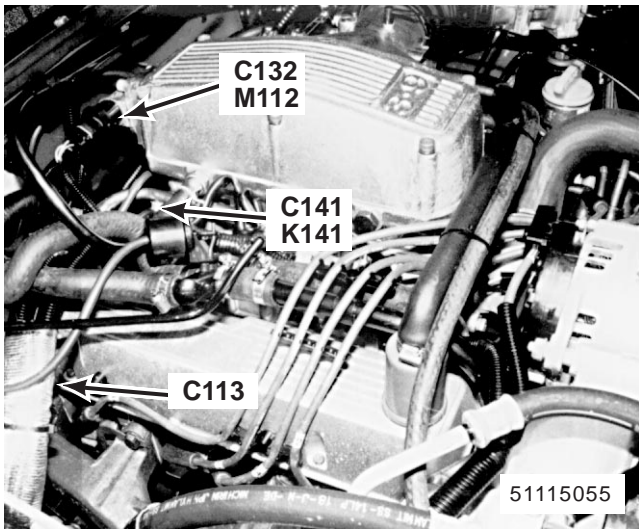

57. RH side of engine MFI-V8  
 K141 Fuel Injectors  
 M112 Idle Air Control Valve  
 C113 (3-W)  
 C132 (4-B)  
 C141 (2-B)

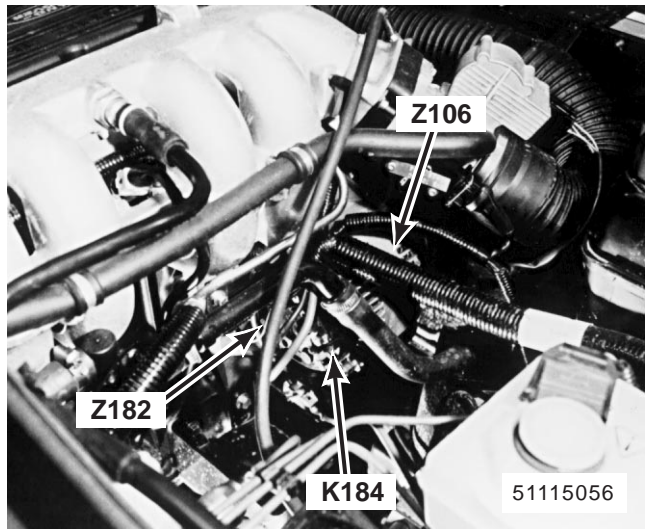

58. RH side of engine MFI-T16 without Air Conditioning  
 K184 Phase Tap Resistor  
 Z106 Generator  
 Z182 Generator Suppression Capacitor

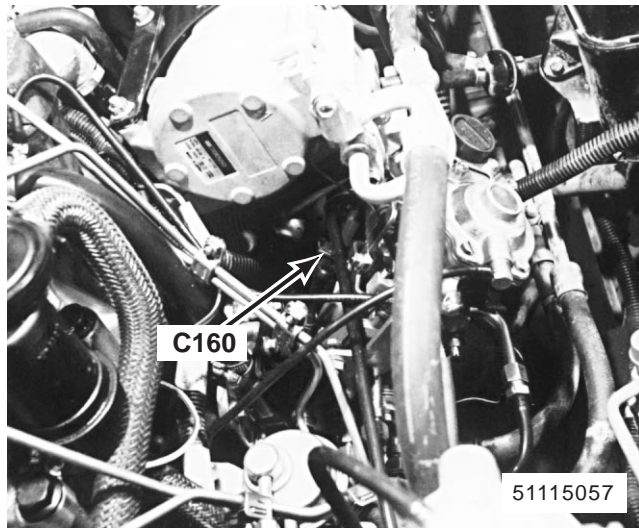

59. RH side of engine 300Tdi with EGR  
 C160 (3-B)

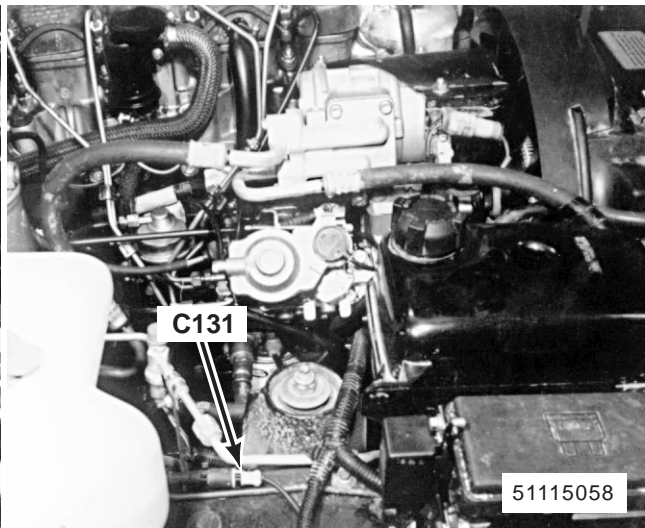

60. RH side of engine compartment  
 C131 (2-W)

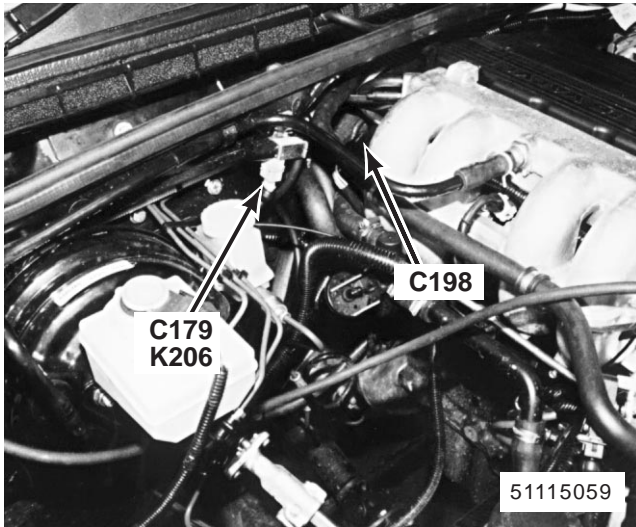

61. RH rear corner of engine compartment MFI-T16  
 K206 Water Valve  
 C179 (2-U)  
 C198 (6-B)

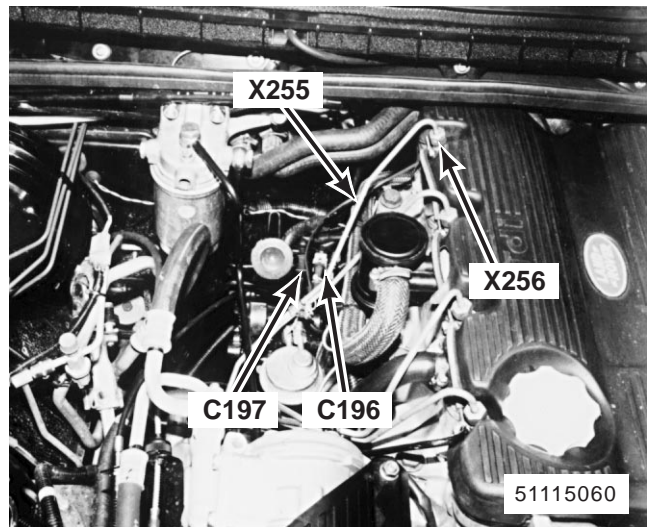

62. RH rear of engine 300Tdi with EDC  
 X255 Engine Speed Sensor  
 X256 Injector Needle Lift Sensor  
 C196 (2-NU)  
 C197 (3-B)

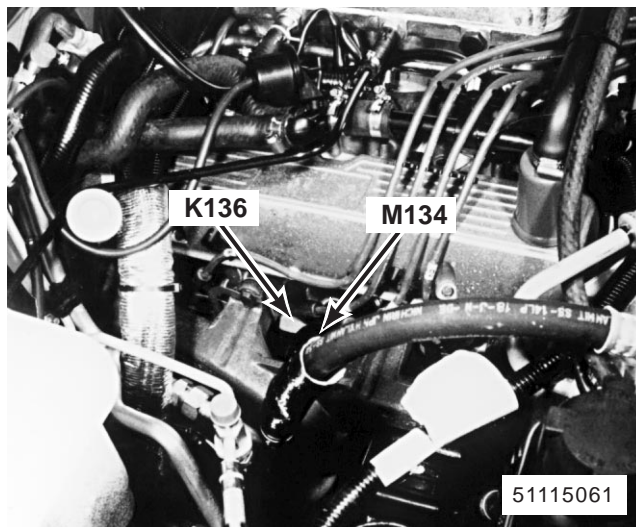

63. lower RH side of engine MFI-V8  
 K136 Starter Solenoid  
 M134 Starter

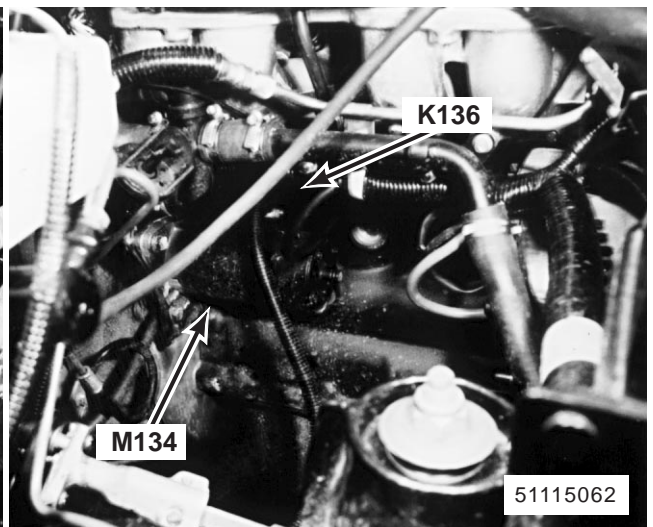

64. lower RH side of engine MFI-T16  
 K136 Starter Solenoid  
 M134 Starter



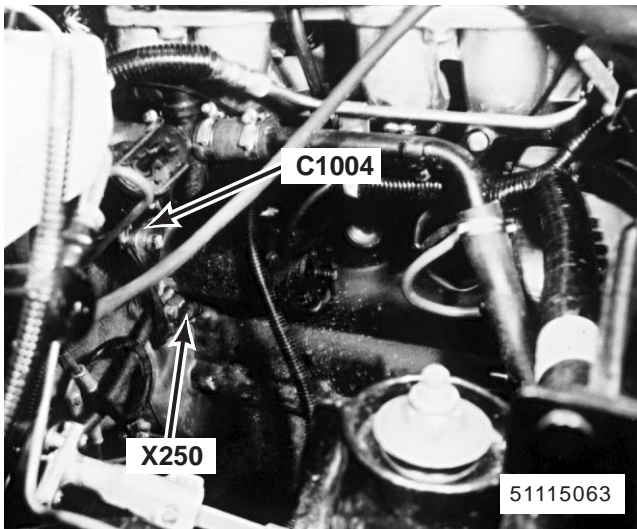

65. lower RH side of engine MFI-T16  
X250 Crankshaft Position Sensor  
C1004 (2-U)

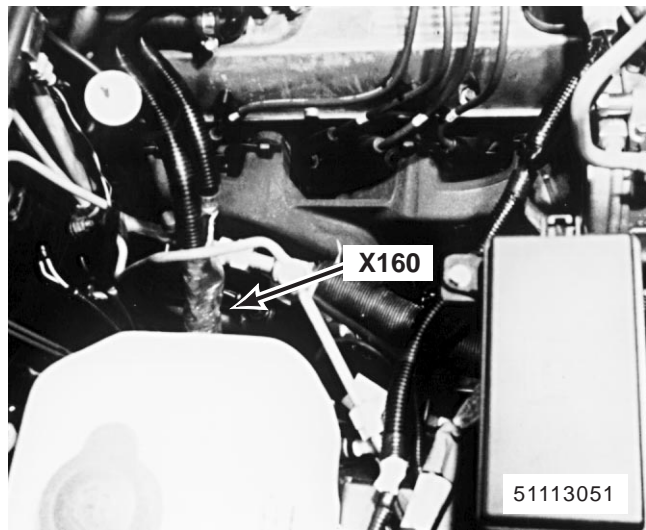

66. lower RH side of engine MFI-V8  
X160 Right Heated Oxygen Sensor

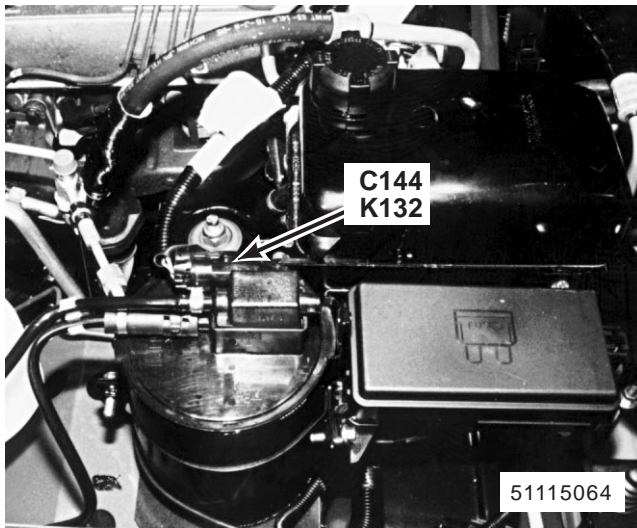

67. RH side of engine compartment MFI-V8  
K132 Evaporative Emission Canister Purge Valve  
C144 (2-RU)

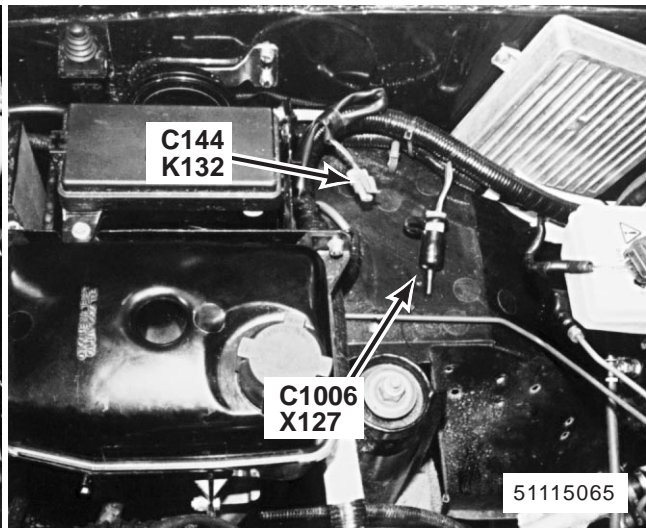

68. RH rear corner of engine compartment  
MFI-T16  
K132 Evaporative Emission Canister Purge Valve  
X127 Data Link Connectors  
C144 (2-RU)  
C1006 (3-W)

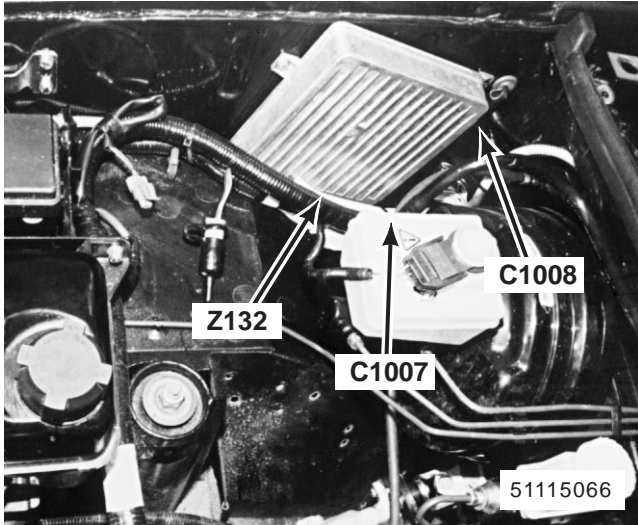

69. RH rear corner of engine compartment MFI-T16  
 Z132 Engine Control Module (ECM)  
 C1007 (36-B)  
 C1008 (18-B)

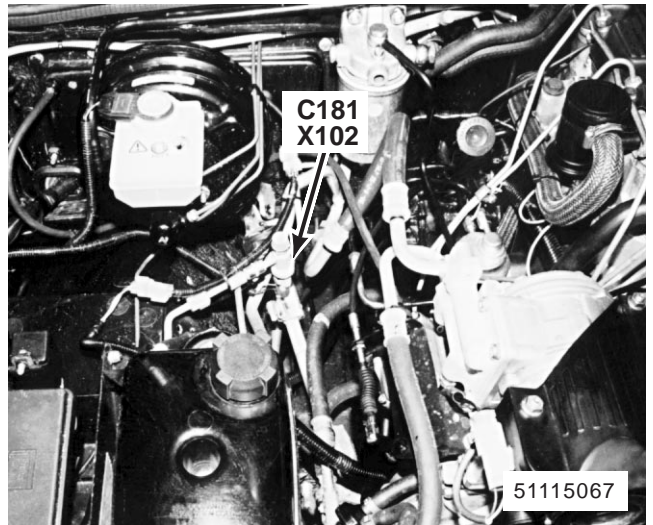

70. RH rear corner of engine compartment X102 A/C Dual Pressure Switch  
 C181 (2-S)

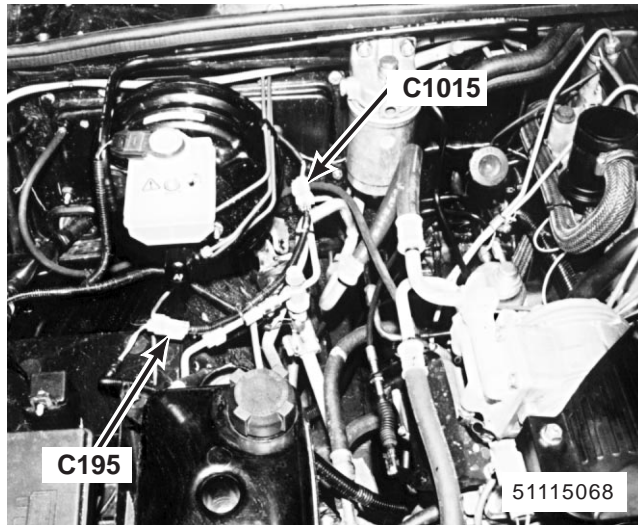

71. RH rear corner of engine compartment 300Tdi with EDC  
 C195 (4-W)  
 C1015 (4-W)

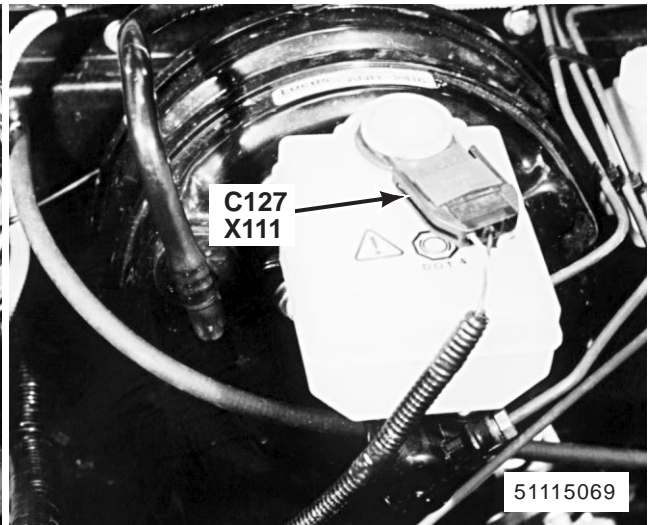

72. RH rear corner of engine compartment X111 Brake Fluid Level Switch  
 C127 (3-B)



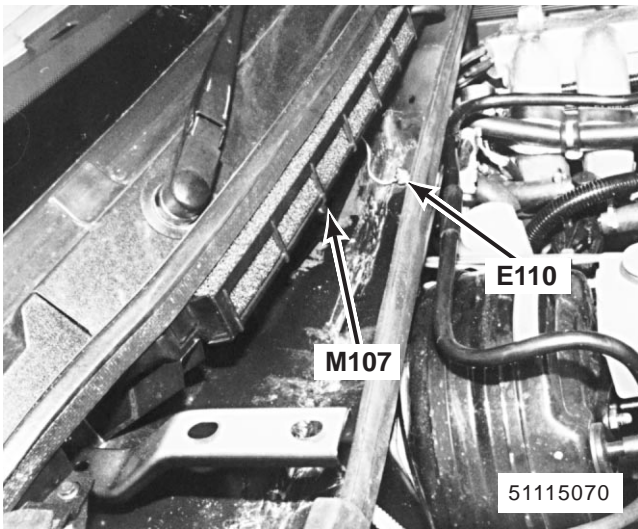

73. RH rear corner of engine compartment  
M107 Front Wiper Motor  
E110

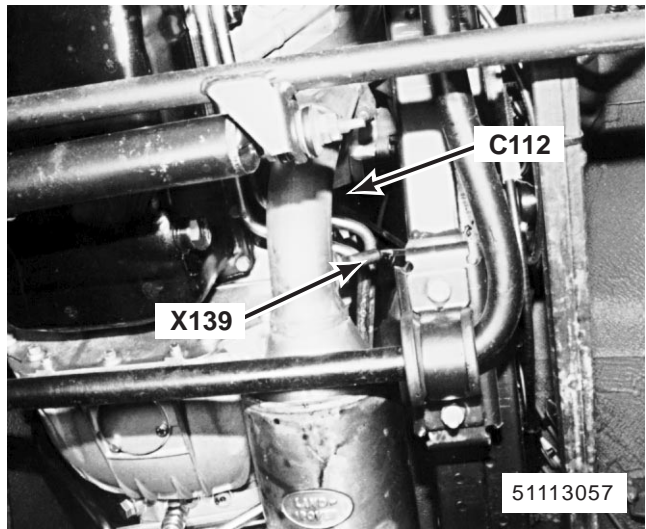

74. lower LH side of engine compartment MFI-V8  
X139 Left Heated Oxygen Sensor  
C112 (3-W)

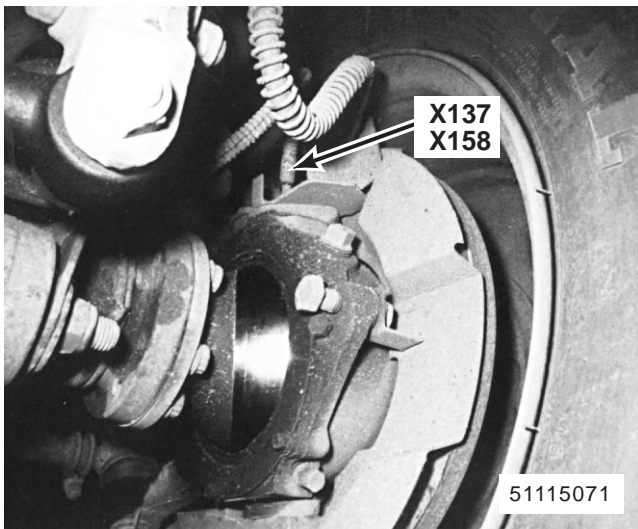

75. behind LH front wheel on handbrake lever  
(RH front wheel similar)  
X137 Left Front Wheel Speed Sensor  
X158 Right Front Wheel Speed Sensor

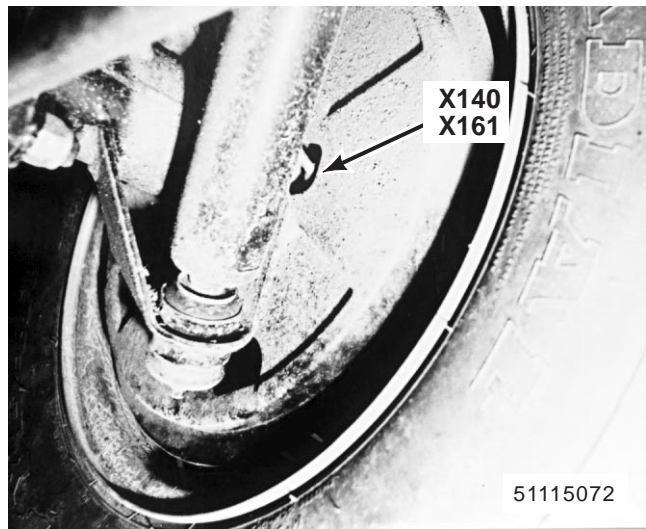

76. behind LH rear wheel (RH rear wheel similar)  
X140 Left Rear Wheel Speed Sensor  
X161 Right Rear Wheel Speed Sensor

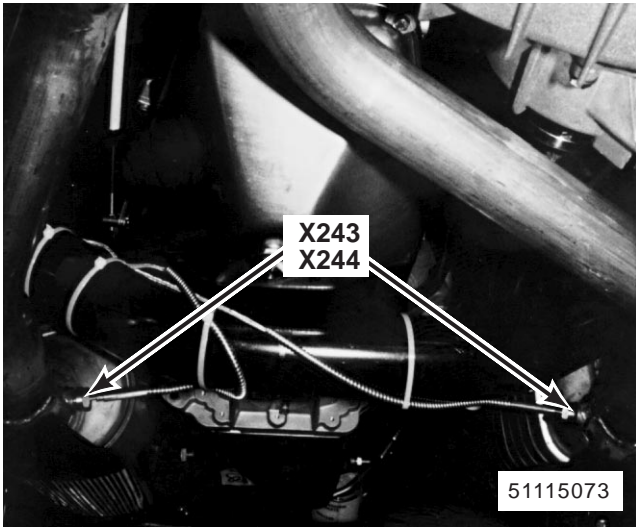

77. LH side of transmission  
 X243 Catalyst Thermocouple 1  
 X244 Catalyst Thermocouple 2

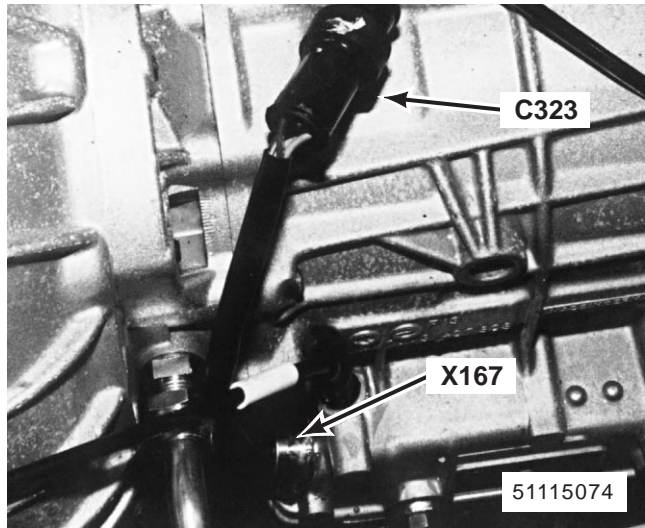

78. LH side of transmission  
 X167 Park/Neutral Position Switch  
 C323 (5-B)

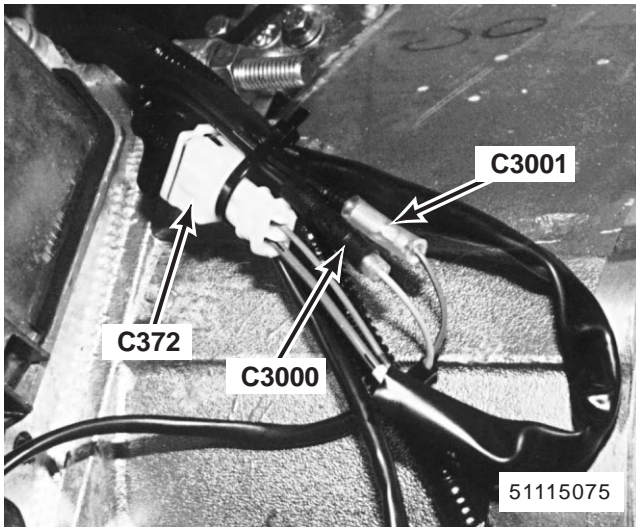

79. LH side of transmission  
 C372 (2-W)  
 C3000 (1-B)  
 C3001 (1-B)

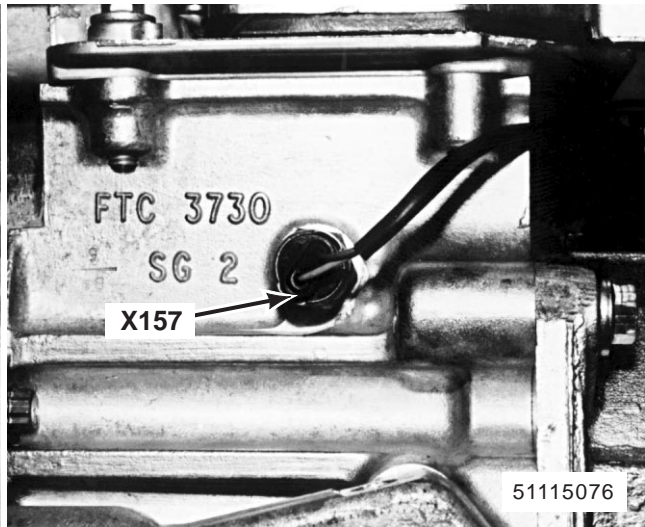

80. LH side of transmission  
 X157 Reverse Switch



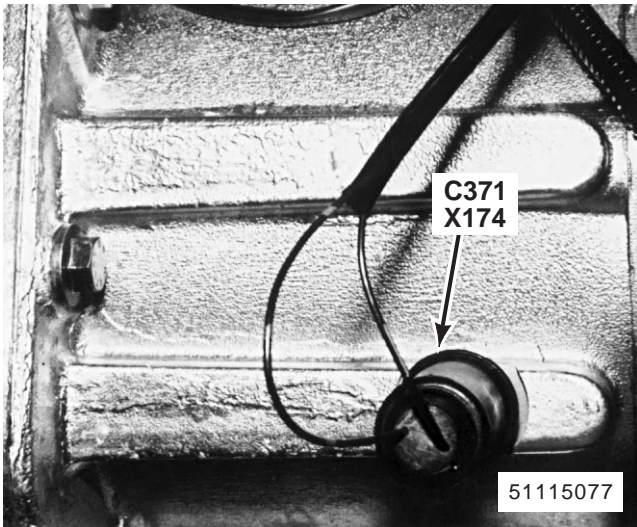

81. LH side of transfer box  
X174 Transfer Box Oil Temperature Switch  
C371 (2-B)

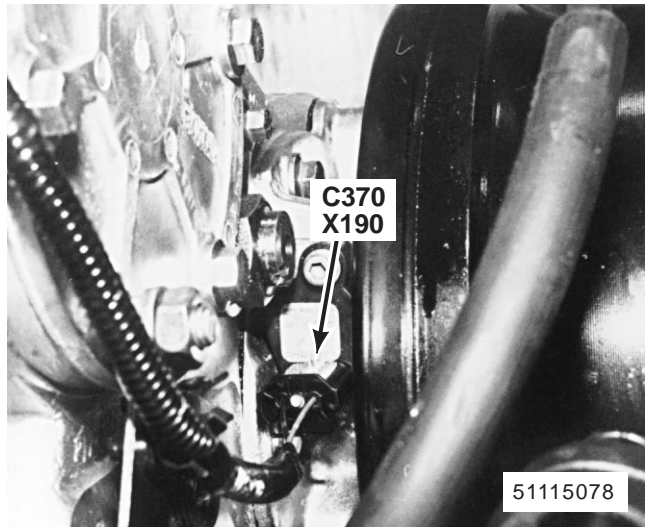

82. LH side of transfer box  
X190 Vehicle Speed Sensor  
C370 (3-B)

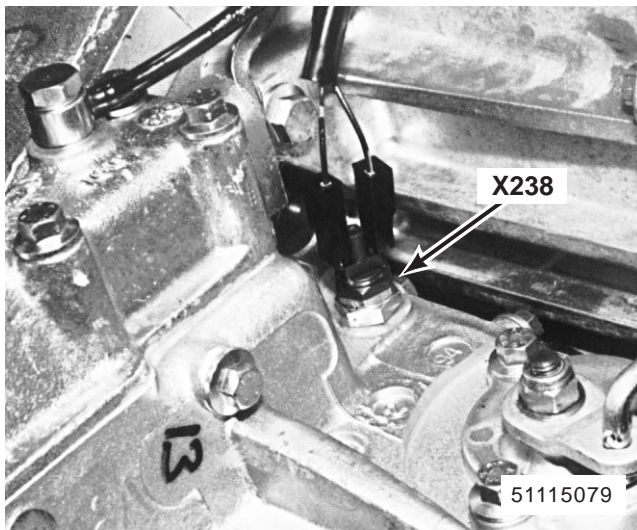

83. top RH side of transfer box  
X238 Differential Lock Switch

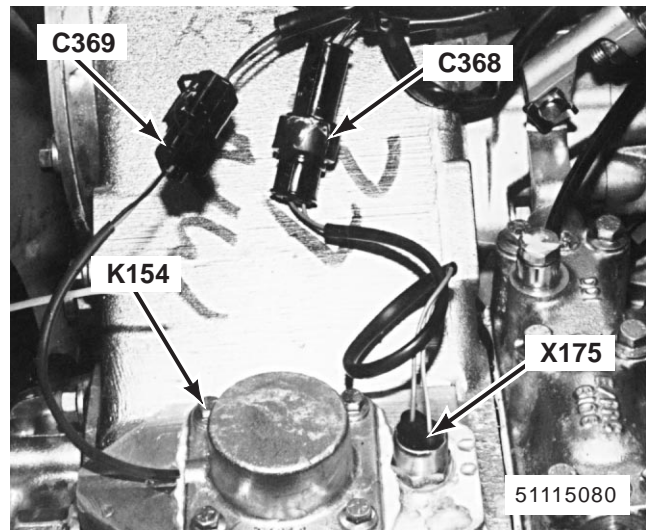

84. top RH side of transfer box  
K154 Transfer Box Drive Motor/Encoder  
X175 Transfer Box Position Switch  
C368 (3-B)  
C369 (2-B)

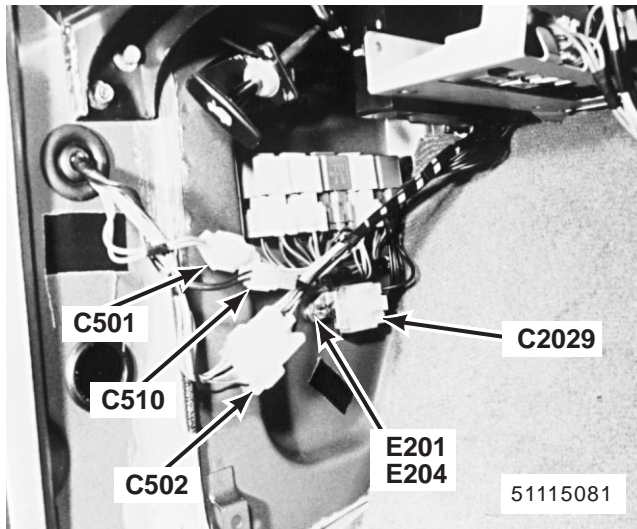

85. behind LH footwell trim panel  
 C2029 (6-W)  
 C501 (2-W)  
 C502 (13-W)  
 C510 (2-W)  
 E201  
 E204

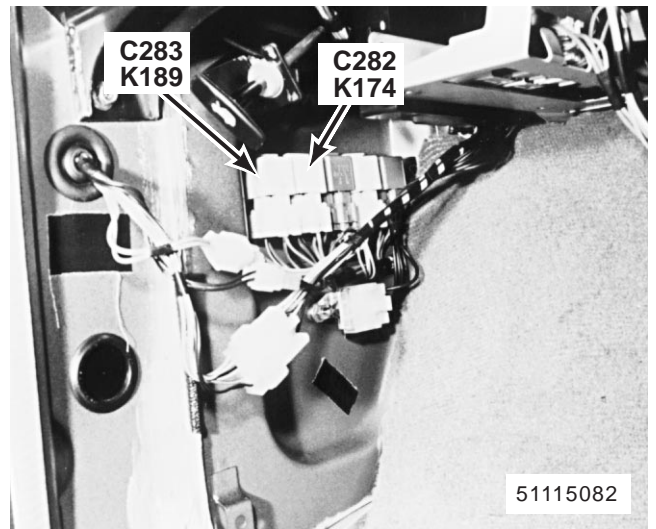

86. behind LH footwell trim panel  
 K174 Accessory Relay  
 K189 Horn Relay  
 C282 (5-Y)  
 C283 (5-Y)

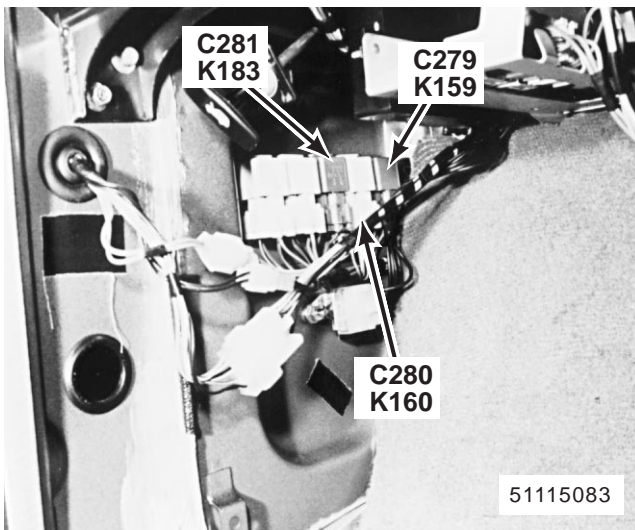

87. behind LH footwell trim panel  
 K159 Theft Alarm Relay  
 K160 Sounder Relay  
 K183 Rear Wiper Relay  
 C279 (5-N)  
 C280 (5-W)  
 C281 (5-G)

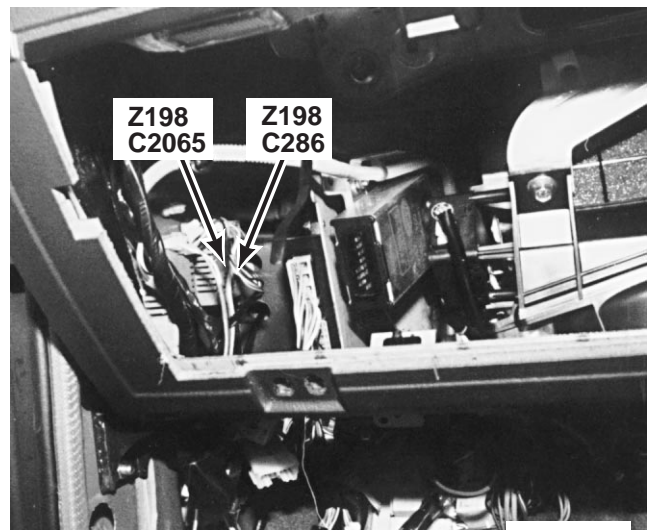

88. behind LH side of fascia  
 Z198 Catalyst Warning ECU 2  
 C286 (4-W)  
 C2065 (2-W)



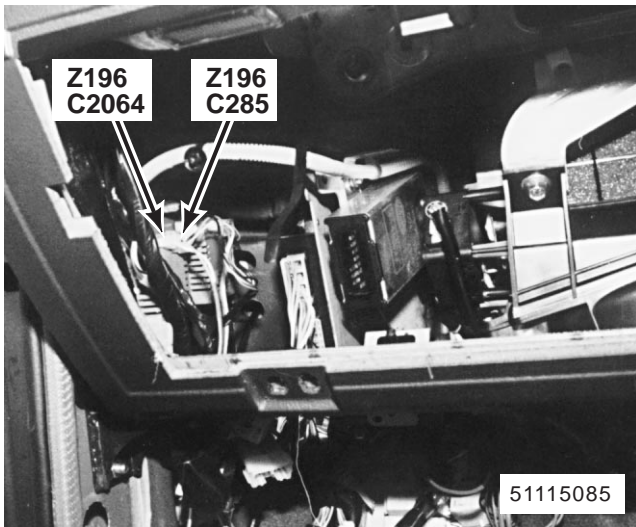

89. behind LH side of fascia  
 Z196 Catalyst Warning ECU 1  
 C285 (4-W)  
 C2064 (2-W)

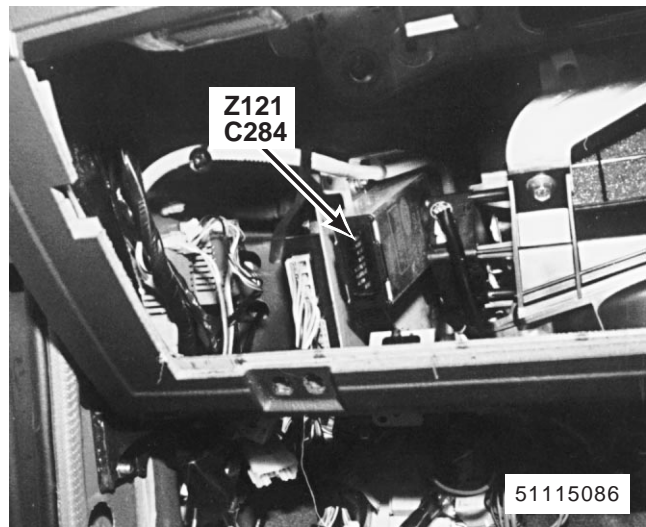

90. behind LH side of fascia  
 Z121 Cruise Control ECU  
 C284 (15-B)

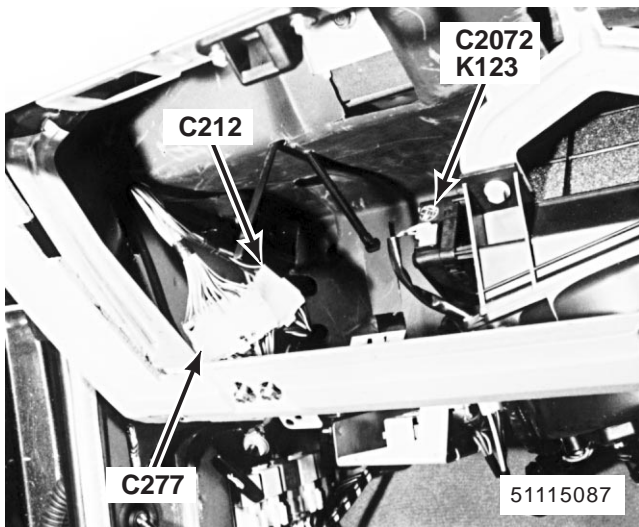

91. behind LH side of fascia  
 K123 Air Recirculation Solenoid  
 C212 (14-W)  
 C277 (23-W)  
 C2072 (4-Y)

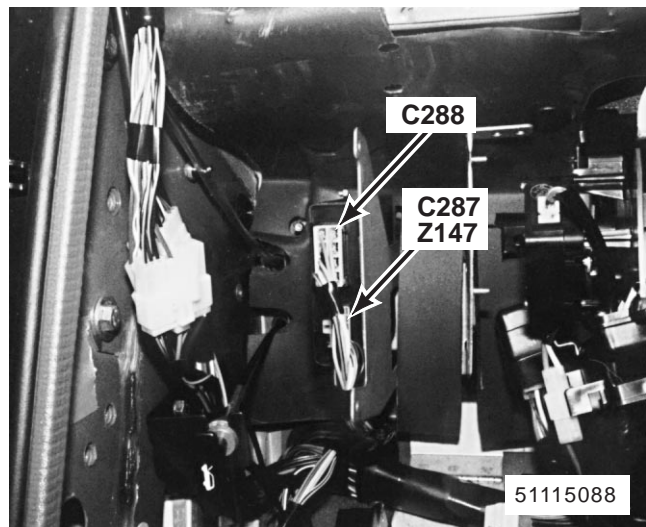

92. behind LH side of fascia  
 Z147 Window Lift ECU  
 C287 (10-W)  
 C288 (8-W)

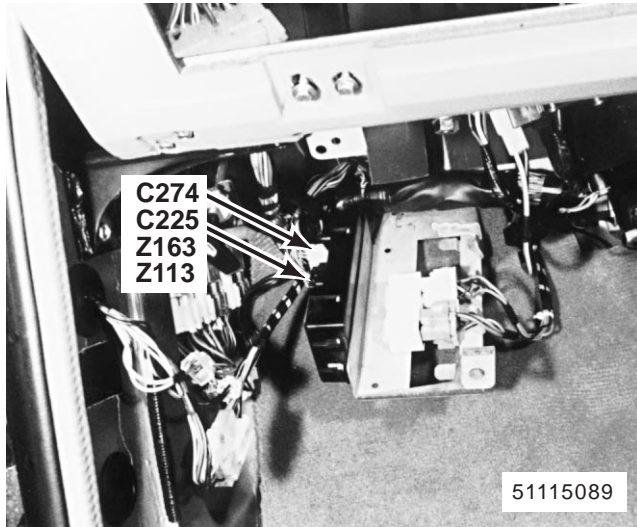

93. behind LH side of fascia  
 Z163 Theft Alarm Unit Except Japan  
 Z113 Central Locking Control Unit Japan  
 C225 (16-B)  
 C274 (6-W)

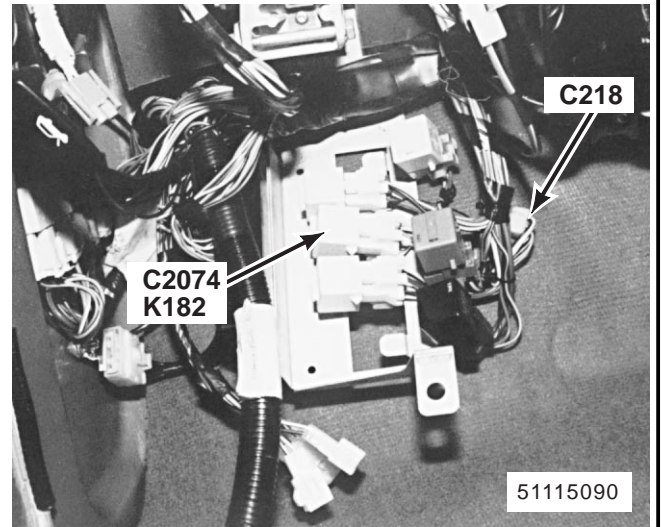

94. behind LH side of fascia  
 K182 Power Wash Relay  
 C218 (8-W)  
 C2074 (5-Y)

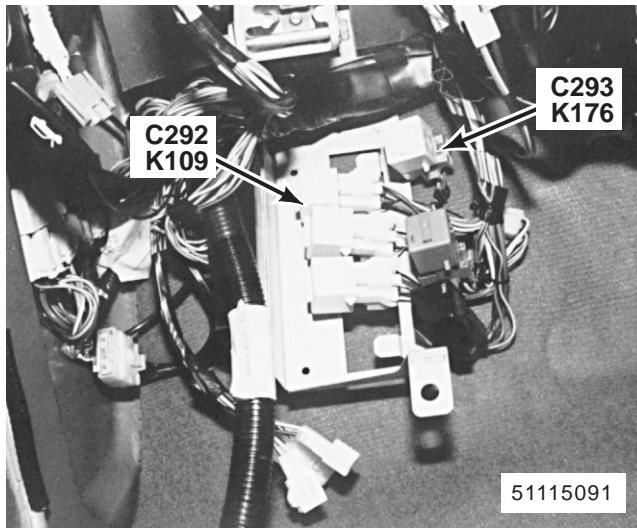

95. behind LH side of fascia  
 K109 Condenser Fan Relay  
 K176 Dim/Dip Relay  
 C292 (5-Y)  
 C293 (5-U)

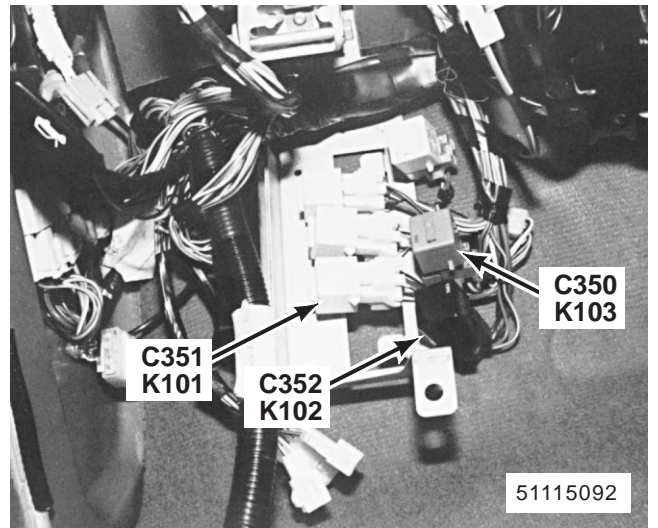

96. behind LH side of fascia  
 K101 A.B.S. Load Relay  
 K102 A.B.S. Pump Relay  
 K103 A.B.S. Warning Relay  
 C350 (5-G)  
 C351 (5-Y)  
 C352 (5-B)



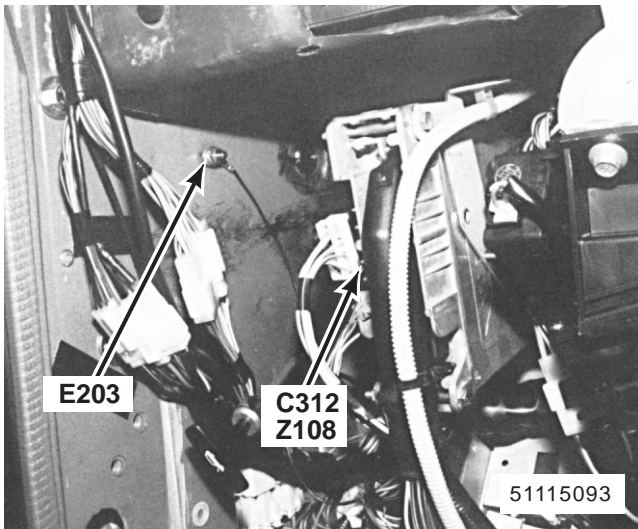

97. behind LH side of fascia  
Z108 Anti-Lock Brake System ECU  
C312 (35-B)  
E203

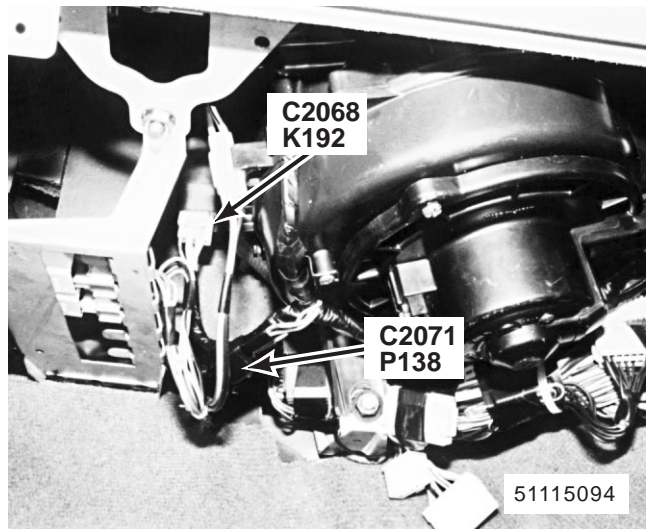

98. behind LH side of fascia  
K192 Front Blower Motor Relay  
P138 Air Recirculation Solenoid In-Line Fuse  
C2068 (5-W)  
C2071 (2-B)

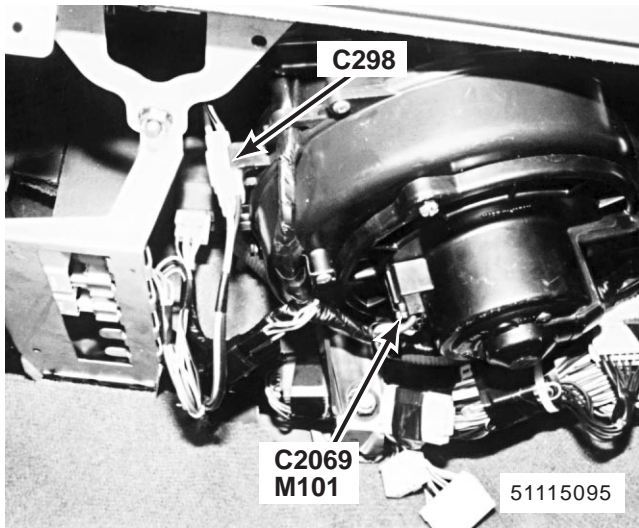

99. behind LH side of fascia  
M101 Front Blower Motor  
C298 (3-W)  
C2069 (2-B)

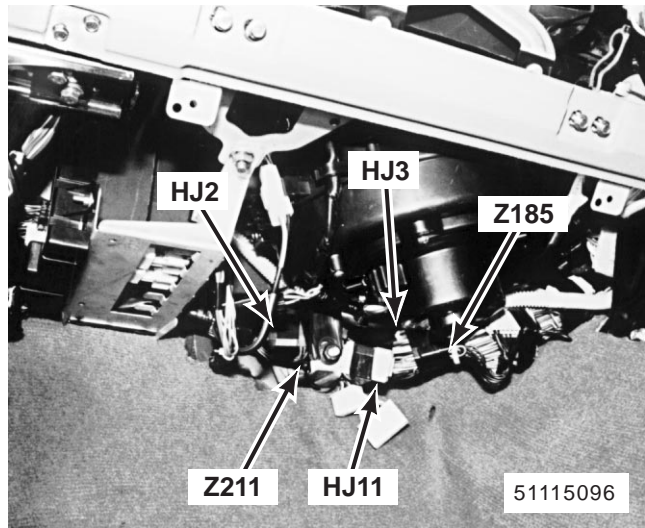

100. behind LH side of fascia  
Z185 Power Mirror Diode  
Z211 Fan Timer Diode  
HJ2 (20-U)  
HJ3 (20-W)  
HJ11 (20-W)

# Z5 ETM

## DISCOVERY

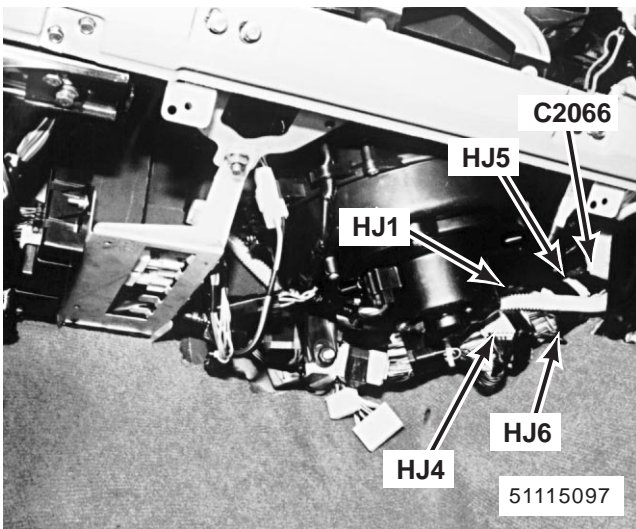

101. behind LH side of fascia  
 C2066 (8-W)  
 HJ1 (20-W)  
 HJ4 (20-W)  
 HJ5 (20-W)  
 HJ6 (20-G)

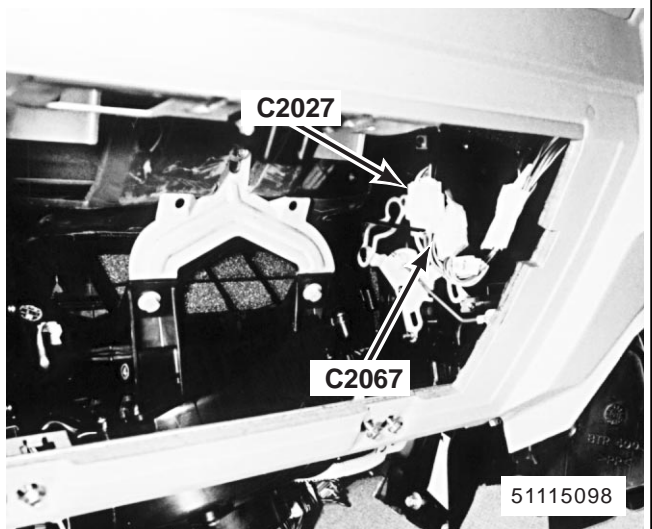

102. behind LH side of fascia  
 C2027 (5-W)  
 C2067 (10-W)

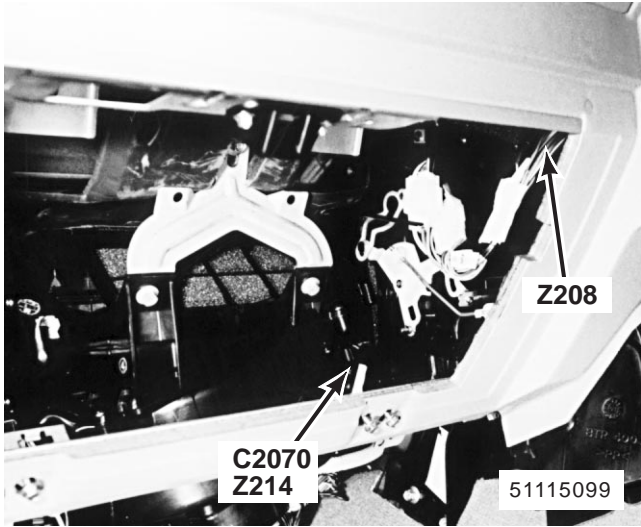

103. behind LH side of fascia  
 Z208 Air Supply Selector Diode  
 Z214 Front Blower Resistor Unit  
 C2070 (4-B)

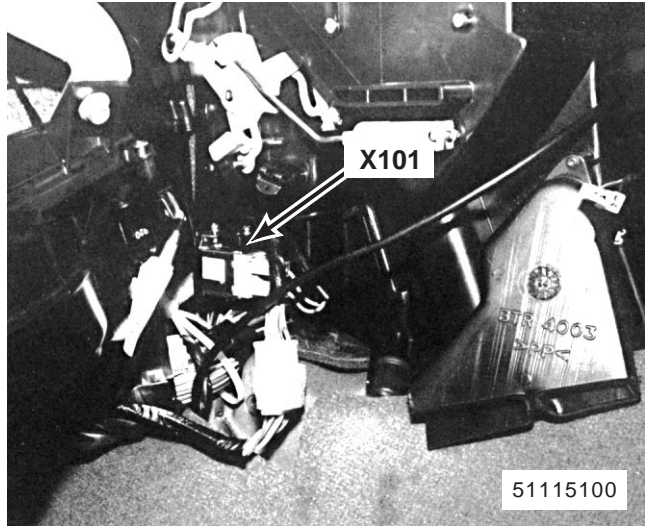

104. LH side of heater evaporator unit  
 X101 Front A/C Evaporator Temperature Switch



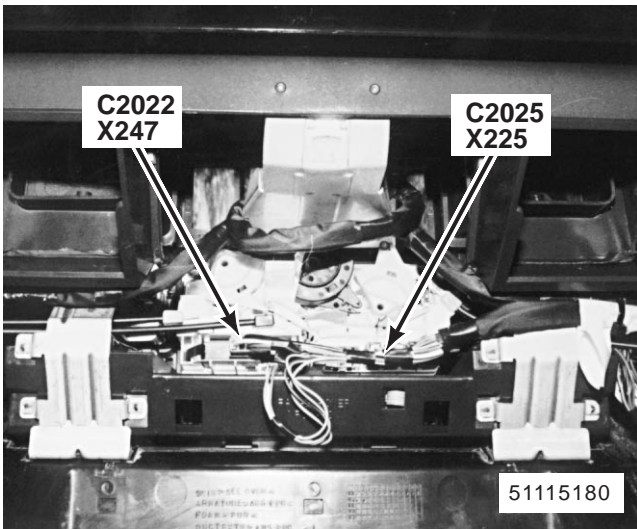

105. behind heater and A/C control panel  
 X247 Front Fan Speed Switch  
 X225 Front A/C Switch  
 C2022 (5-W)  
 C2025 (5-W)

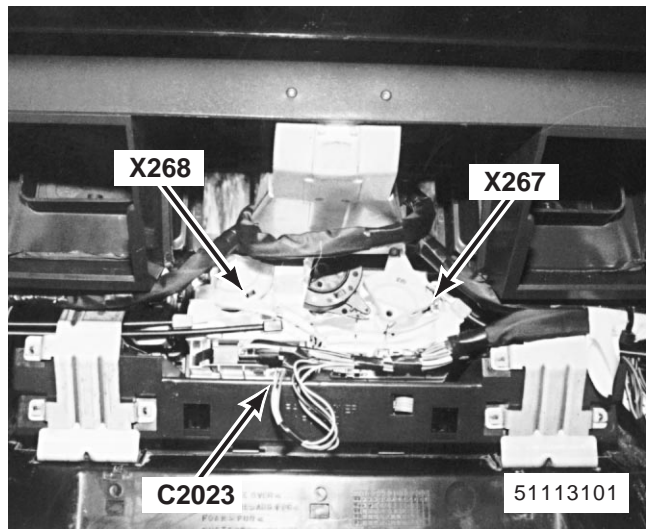

106. behind heater and A/C control panel  
 X267 Left Maximum Cool Switch  
 X268 Right Maximum Cool Switch  
 C2023 (4-W)

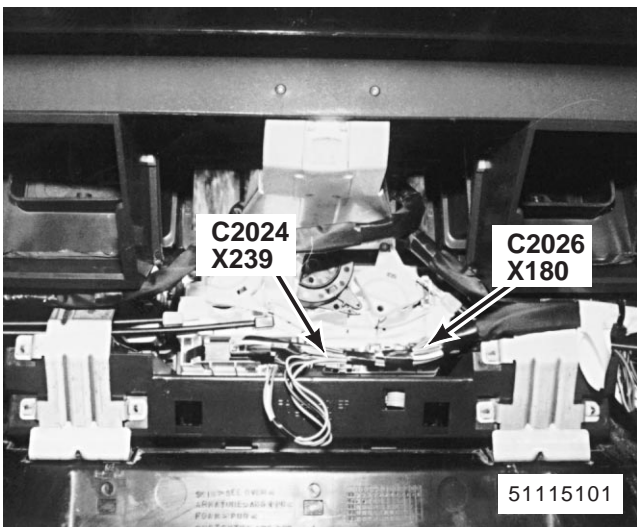

107. behind heater and A/C control panel  
 X180 Air Supply Selector Switch  
 X239 Main Rear A/C Switch  
 C2024 (5-W)  
 C2026 (5-B)

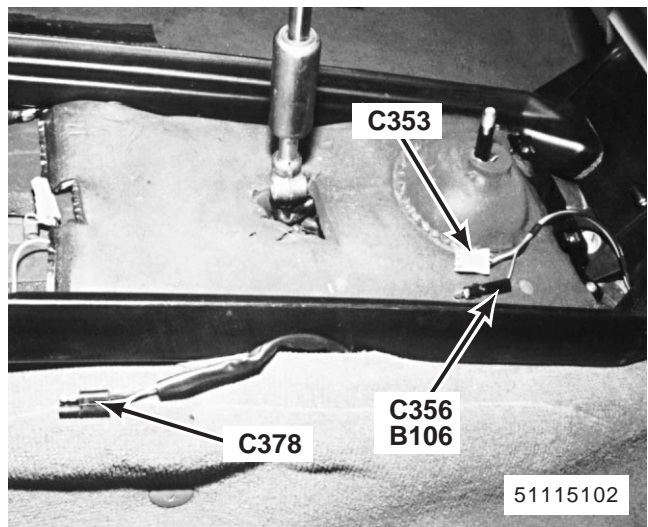

108. beneath centre console  
 B106 Fascia Cigar Lighter  
 C353 (2-W)  
 C356 (1-B)  
 C378 (2-B)

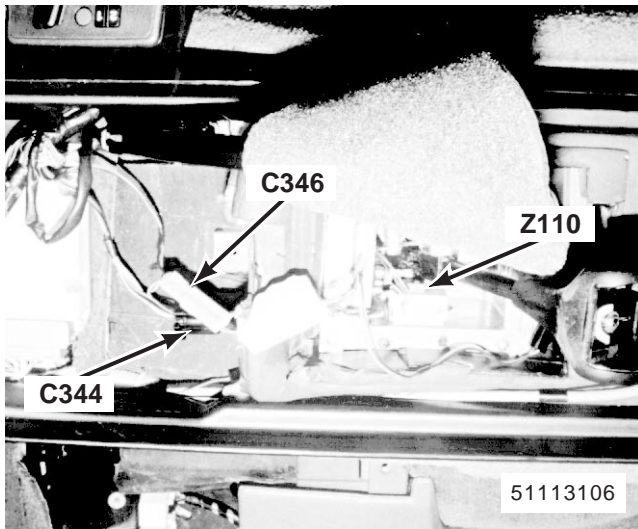

109. beneath centre console  
 Z110 Transmission Range Selector Switch  
 C344 (6-B)  
 C346 (2-U)

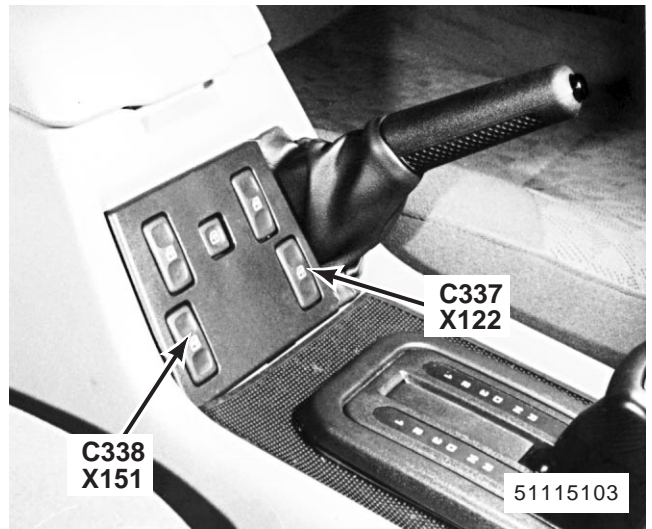

110. in rear of centre console  
 X122 Left Front Window Switch  
 X151 Right Front Window Switch  
 C337 (7-G)  
 C338 (7-W)

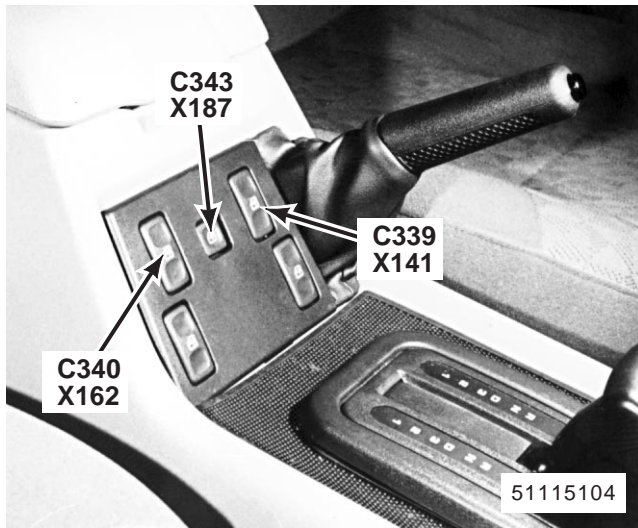

111. in rear of centre console  
 X141 Left Rear Window Console Switch  
 X162 Right Rear Window Console Switch  
 X187 Rear Window Isolation Switch  
 C339 (7-Y)  
 C340 (7-R)  
 C343 (7-N)

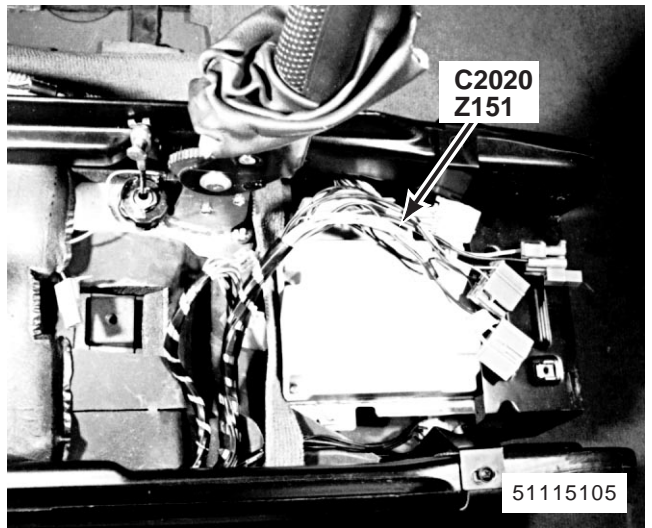

112. beneath centre console  
 Z151 Air Bag Diagnostic Control Module  
 C2020 (29-R)



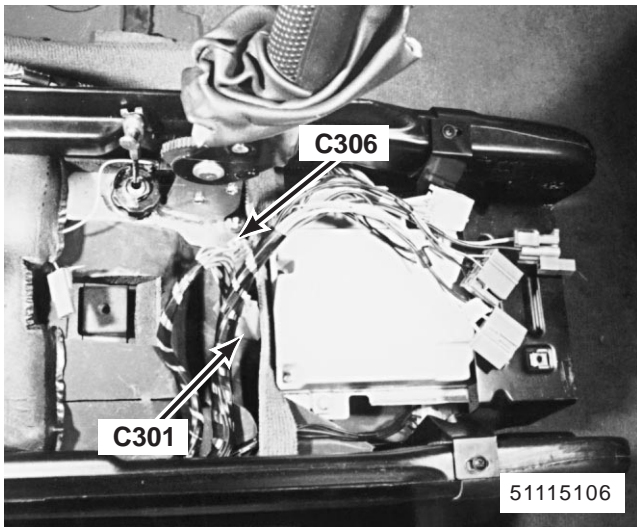

113. beneath centre console  
C301 (6-W)  
C306 (3-W)

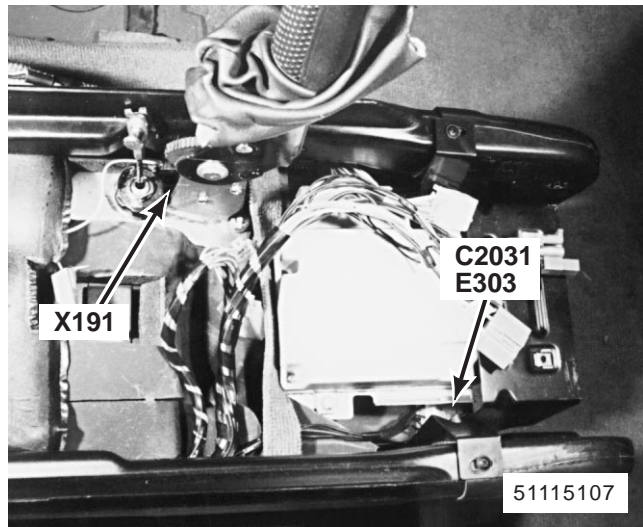

114. beneath centre console  
X191 Handbrake Switch  
C2031 (6-W)  
E303

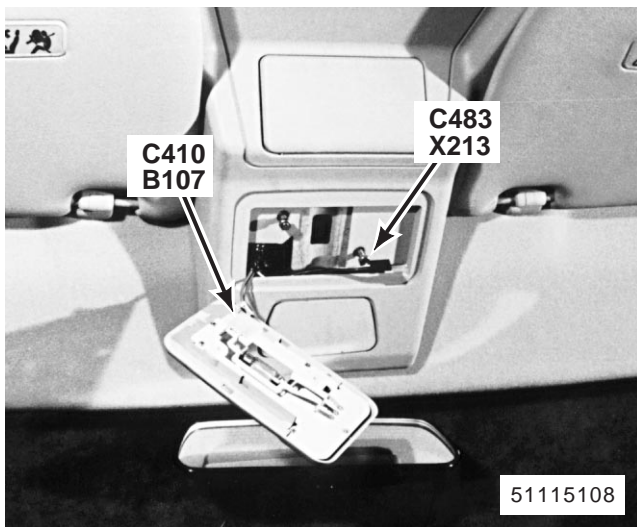

115. front centre of roof  
B107 Front Interior Roof Lamp  
X213 Alarm Sensor  
C410 (3-W)  
C483 (4-B)

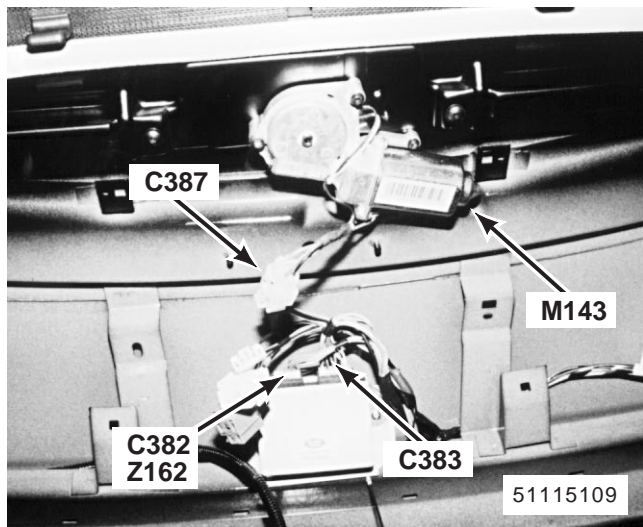

116. front centre of roof  
Z162 Sunroof Control Unit  
M143 Front Sunroof Motor  
C382 (8-W)  
C383 (10-W)  
C387 (4-W)

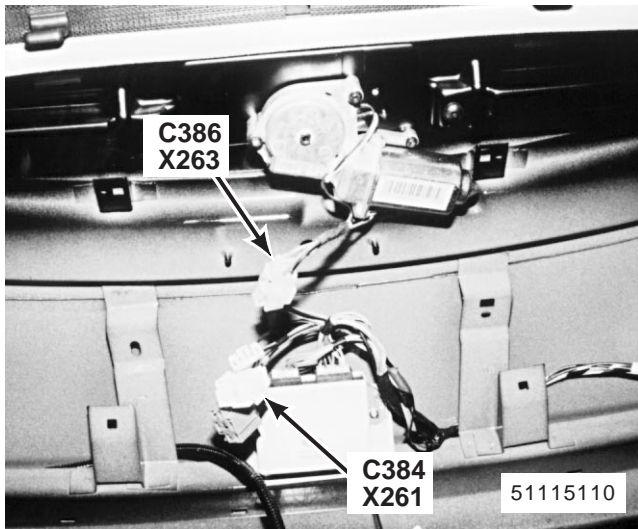

117. front centre of roof  
 X261 Front Sunroof Switch  
 X263 Rear Sunroof Lockout Switch  
 C384 (7-G)  
 C386 (5-S)

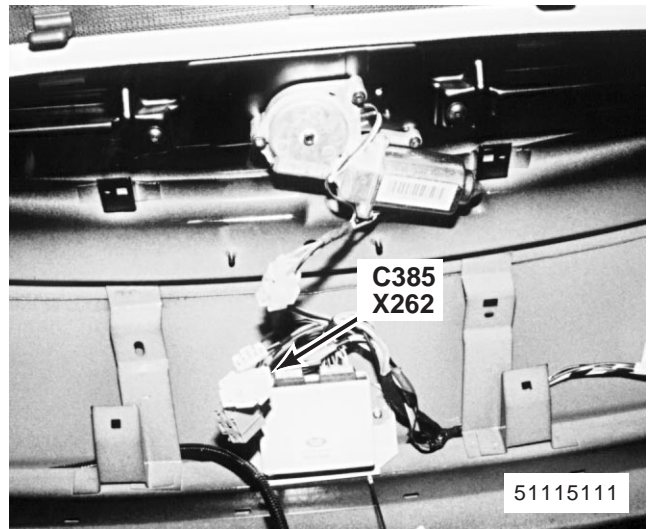

118. front centre of roof  
 X262 Rear Sunroof Switch  
 C385 (7-W)

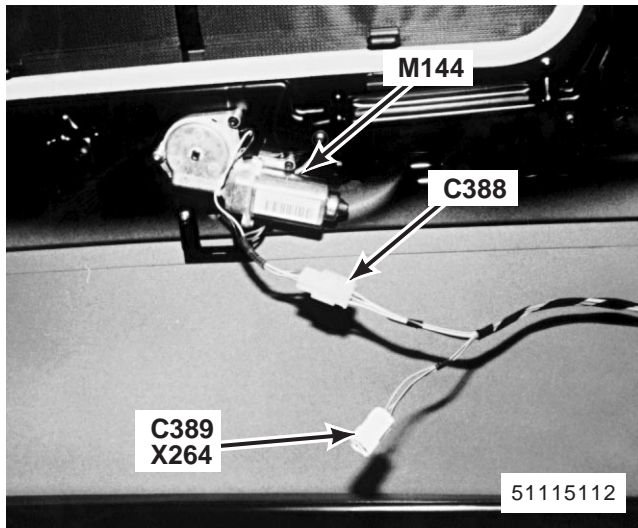

119. centre of roof  
 M144 Rear Sunroof Motor  
 X264 Passenger's Rear Sunroof Switch  
 C388 (4-W)  
 C389 (3-W)

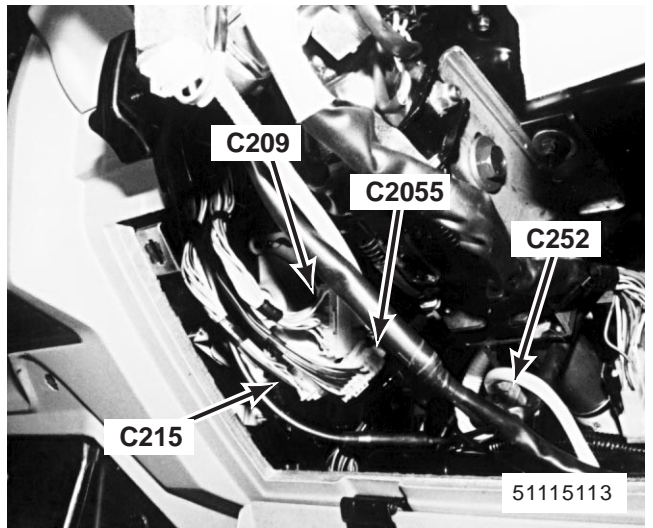

120. behind RH side of fascia left of steering column  
 C209 (24-W)  
 C215 (24-Y)  
 C252 (6-R)  
 C2055 (13-W)

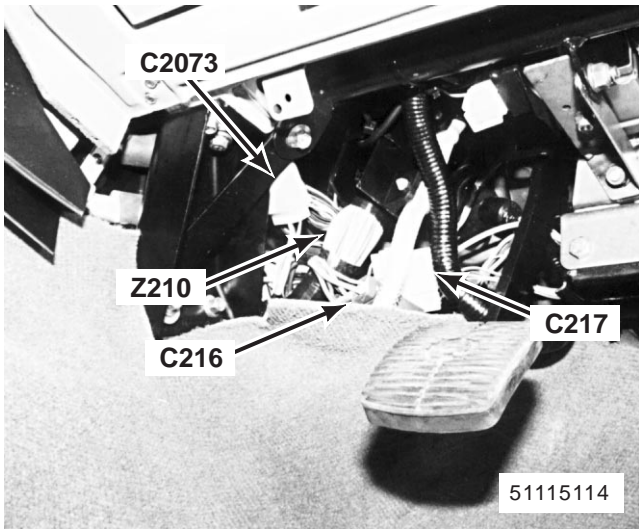

121. behind RH side of fascia right of heater evaporator unit  
 Z210 Condenser Fan Control Diode 2  
 C216 (7-N)  
 C217 (20-W)  
 C2073 (10-W)

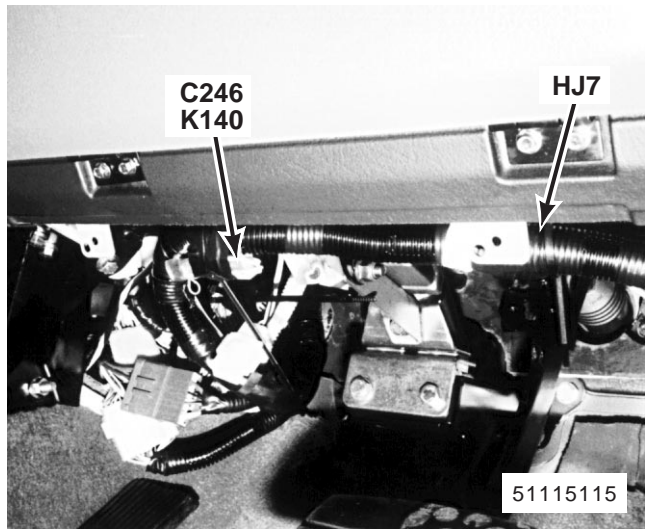

122. behind RH side of fascia  
 K140 Tune Select Resistor  
 C246 (2-U)  
 HJ7 (20-U)



123. behind RH side of fascia right of steering column  
 X257 Throttle Position Sensor

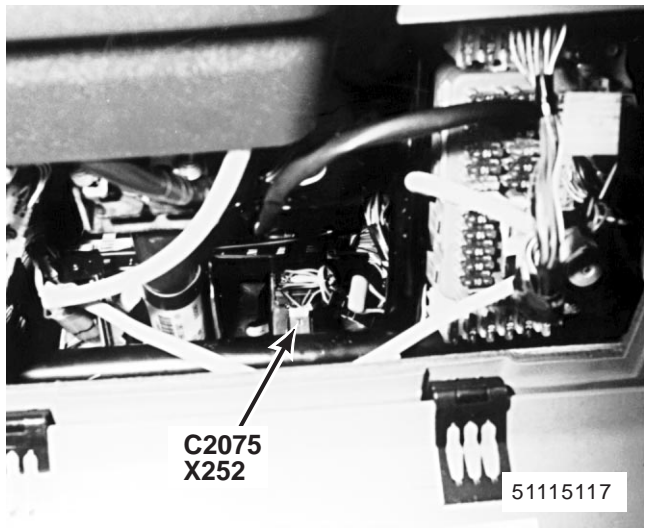

124. behind RH side of fascia right of steering column  
 X252 EDC Stop Lamp Switch  
 C2075 (3-W)



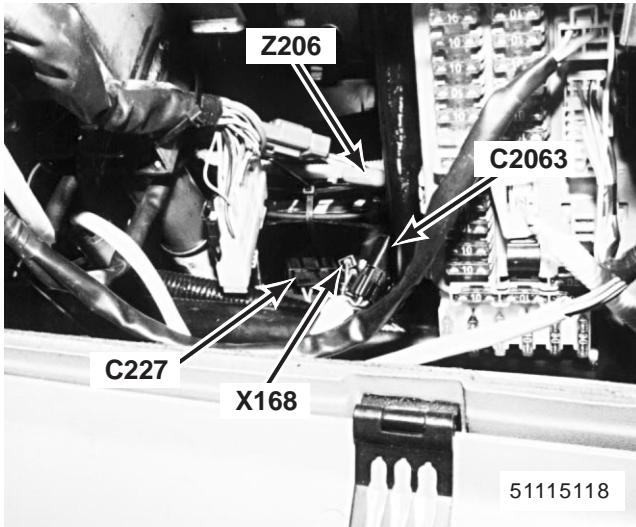

125. behind RH side of fascia right of steering column  
 X168 Stop Lamp Switch  
 Z206 Stop Lamp Switch Suppressor  
 C227 (4-B)  
 C2063 (2-B)

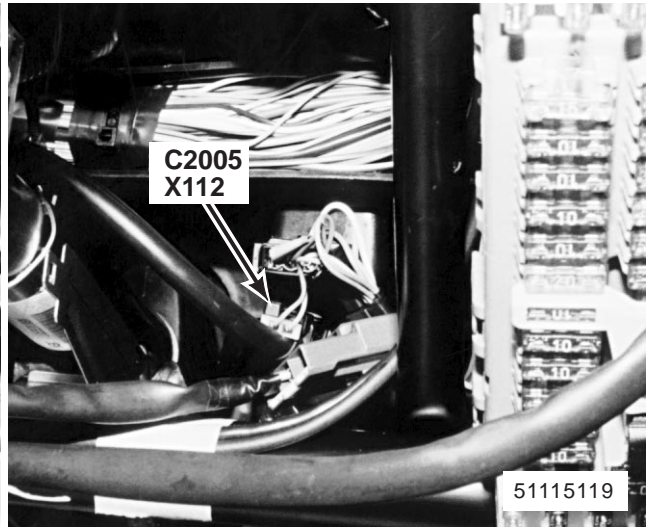

126. behind RH side of fascia right of steering column  
 X112 Brake Switch Vent Valve  
 C2005 (2-W)

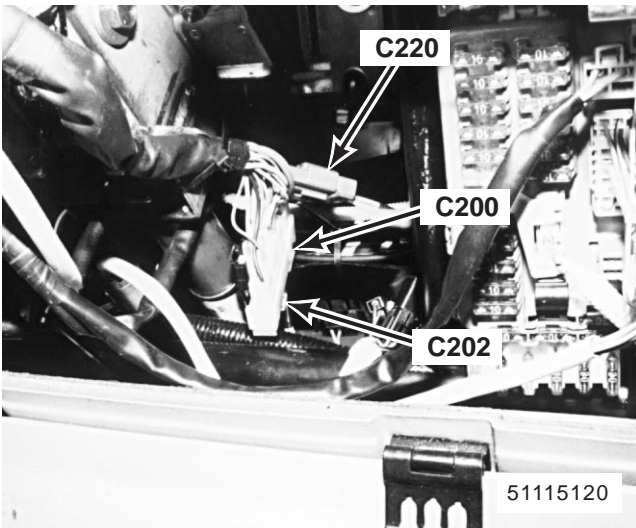

127. behind RH side of fascia right of steering column  
 C200 (4-W)  
 C202 (24-W)  
 C220 (3-N)

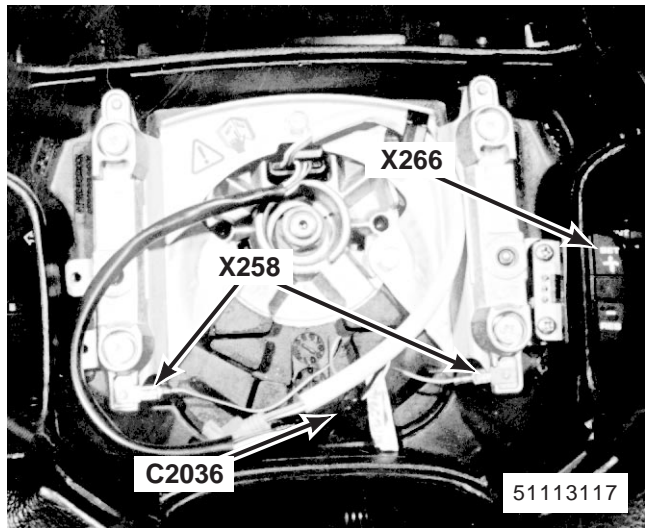

128. in steering wheel  
 X258 Horn Switches  
 X266 Steering Wheel Cruise Switches  
 C2036 (7-B)

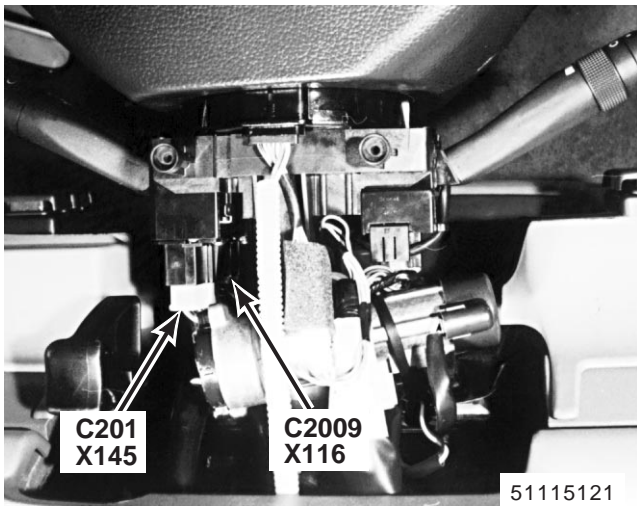

129. underside of steering column  
 X116 Direction Indicator Switch  
 X145 Main Lighting Switch  
 C201 (7-W)  
 C2009 (4-W)

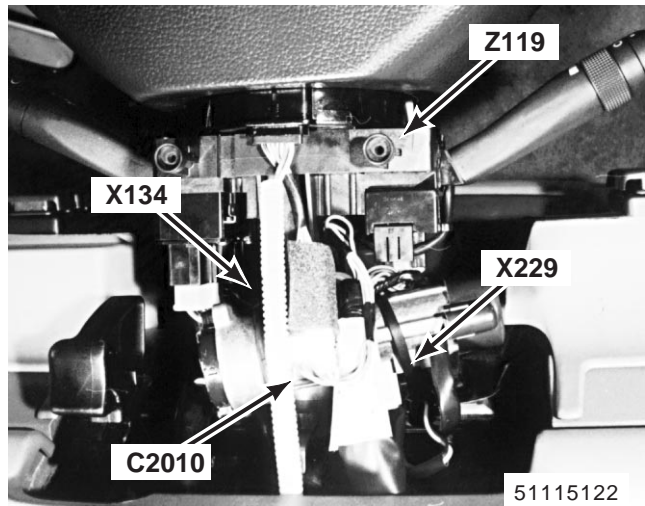

130. underside of steering column  
 X134 Ignition Switch  
 X229 Key-In Switch  
 Z119 Rotary Coupler  
 C2010 (6-W)

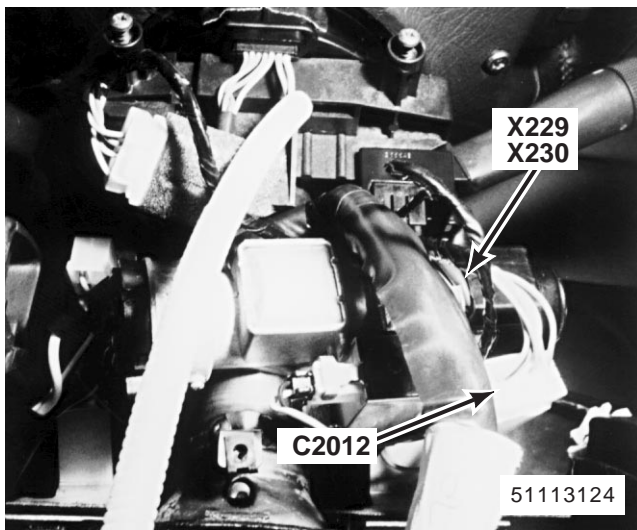

131. underside of steering column  
 X229 Key-In Switch  
 X230 Key-Barrel Switch  
 C2012 (8-W)

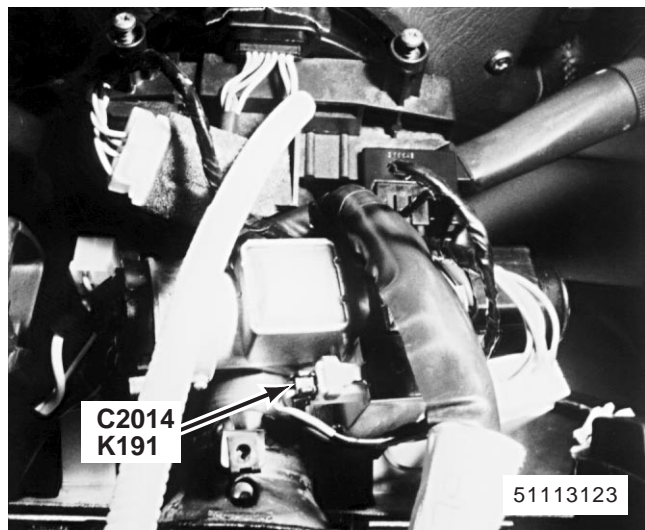

132. underside of steering column  
 K191 Ignition Key Lock Solenoid  
 C2014 (2-B)

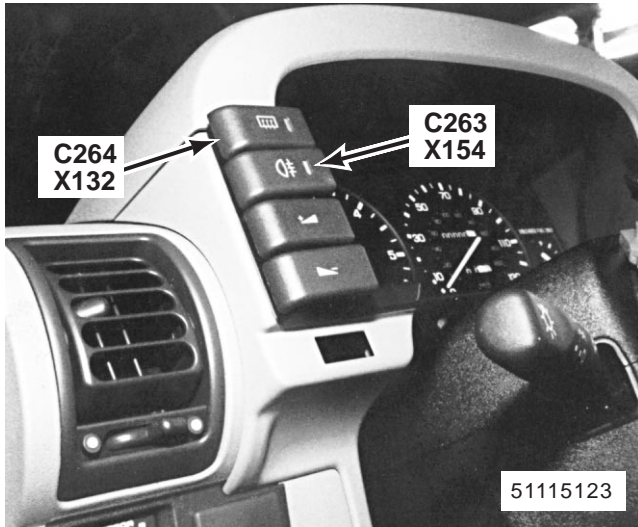

133. top RH side of fascia  
 X132 Heated Rear Screen Switch  
 X154 Rear Fog Guard Lamps Switch  
 C263 (5-U)  
 C264 (5-U)

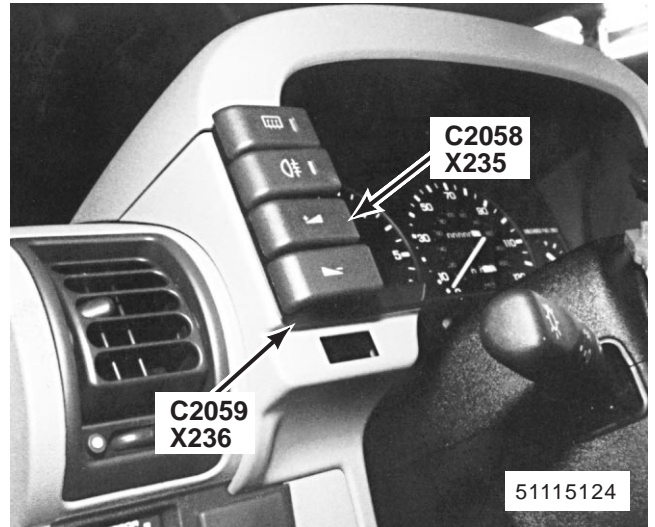

134. top RH side of fascia  
 X235 Radio Volume Up Switch  
 X236 Radio Volume Down Switch  
 C2058 (5-W)  
 C2059 (5-G)

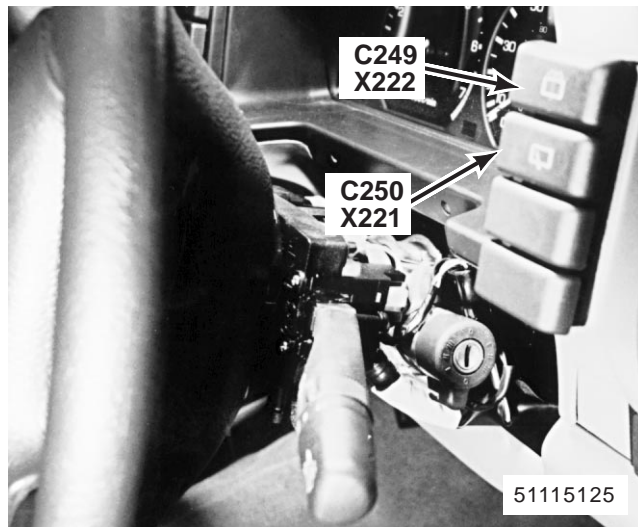

135. top RH side of fascia  
 X221 Rear Screen Wipe Switch  
 X222 Rear Screen Wash Switch  
 C249 (5-G)  
 C250 (5-W)

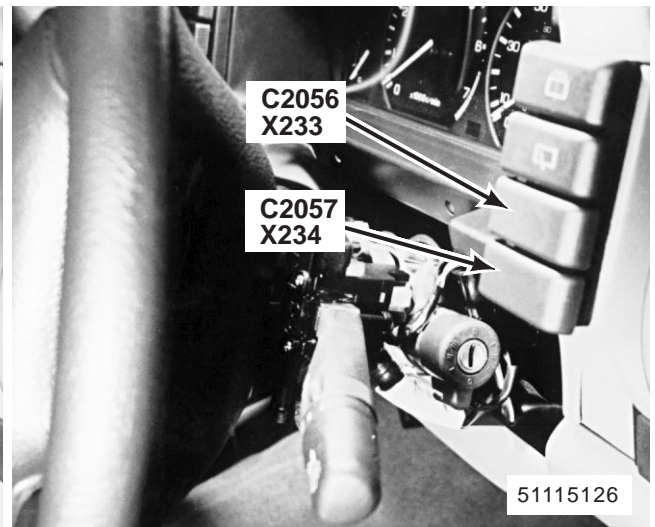

136. top RH side of fascia  
 X233 Radio Tune Switch  
 X234 Radio Waveband Switch  
 C2056 (5-U)  
 C2057 (5-U)



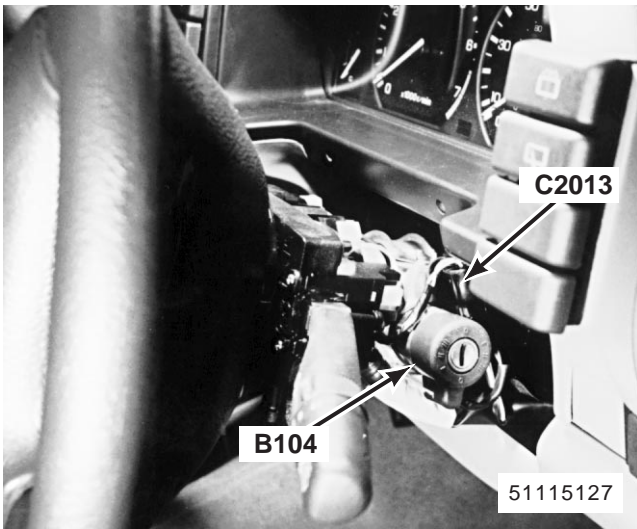

137. top of steering column  
 B104 Column Switch Illumination  
 C2013 (4-B)

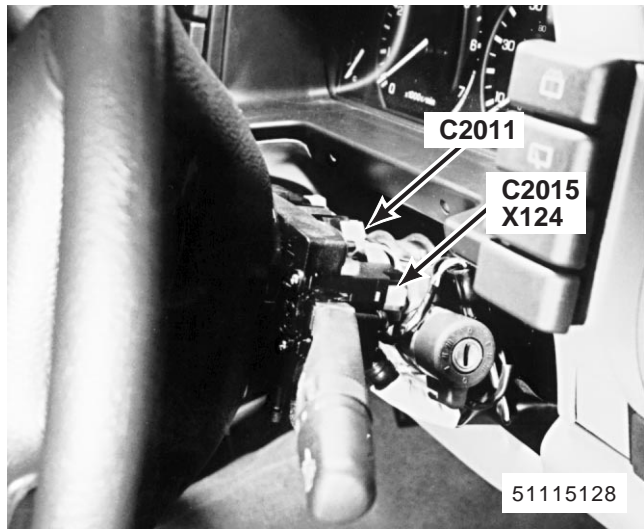

138. top of steering column  
 X124 Front Wipe/Wash Switch  
 C2011 (6-W)  
 C2015 (8-W)

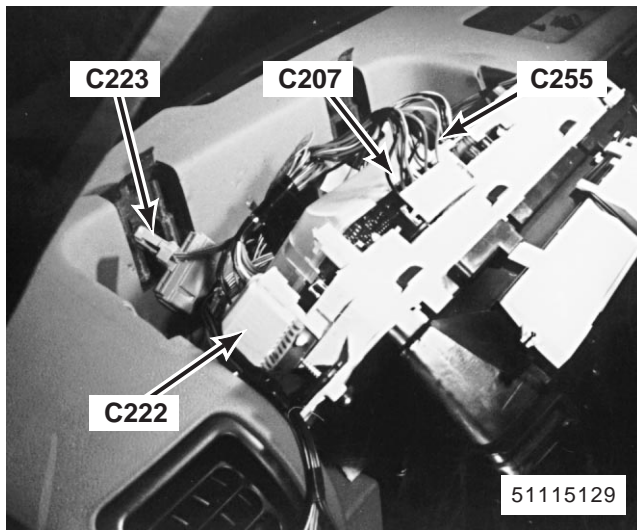

139. behind instrument cluster  
 C207 (10-B)  
 C222 (10-W)  
 C223 (5-U)  
 C255 (1-B)

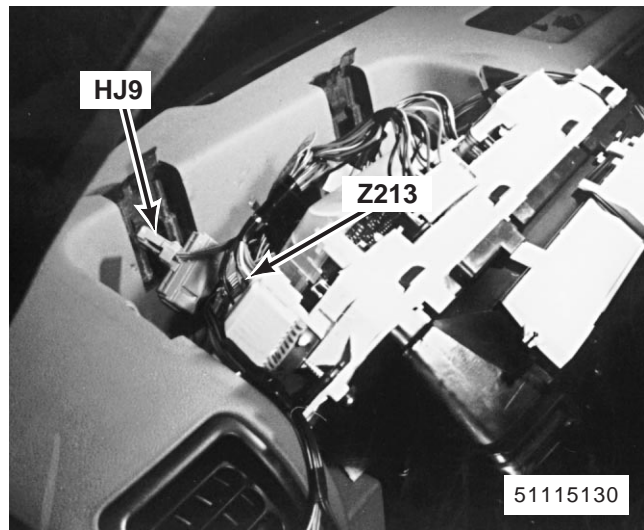

140. behind instrument cluster  
 Z213 Direction Indicator Diode 2  
 HJ9 (20-S)

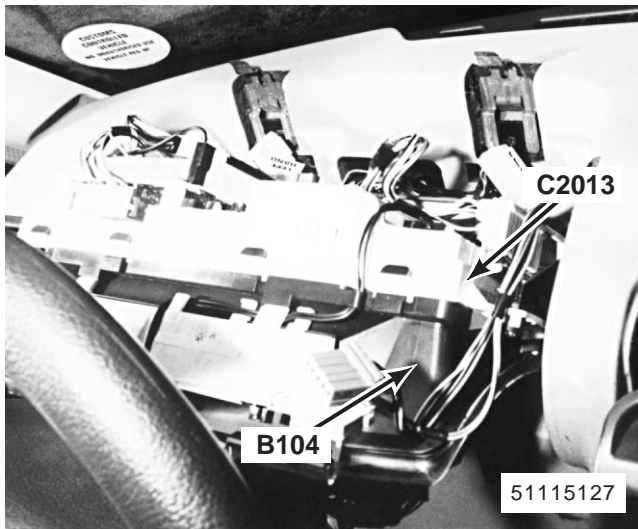

141. behind instrument cluster  
 Z212 Direction Indicator Diode 1  
 C221 (10-W)  
 HJ8 (20-S)

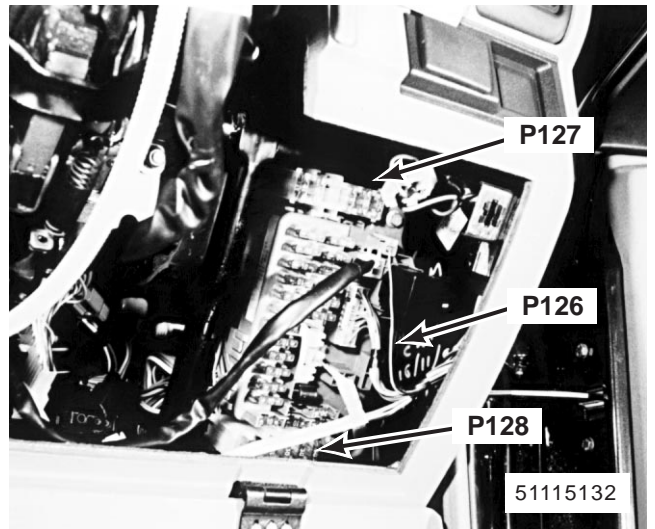

142. behind RH side of fascia right of steering column  
 P126 Fascia Fuse Box  
 P127 Satellite Fuse Box 1  
 P128 Satellite Fuse Box 2

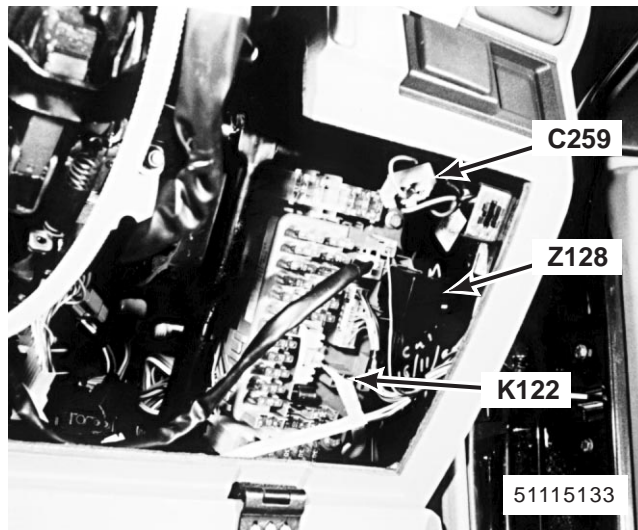

143. behind RH side of fascia right of steering column  
 K122 Heated Rear Screen Relay  
 Z128 Flasher Unit  
 C259 (6-W)

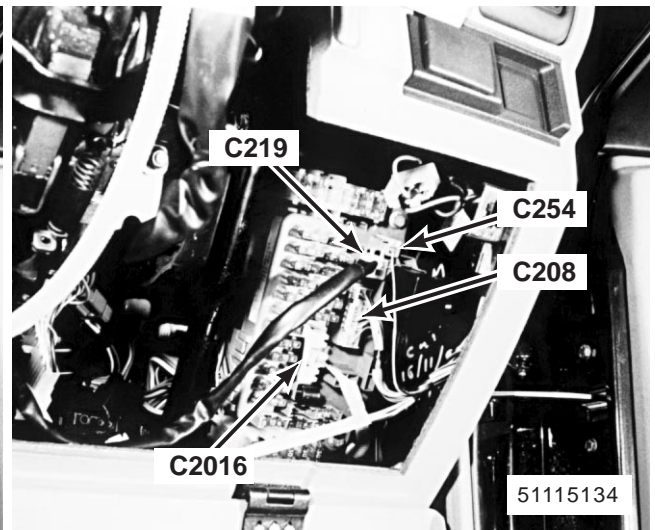

144. behind RH side of fascia right of steering column  
 C208 (18-W)  
 C219 (4-W)  
 C254 (1-W)  
 C2016 (1-W)



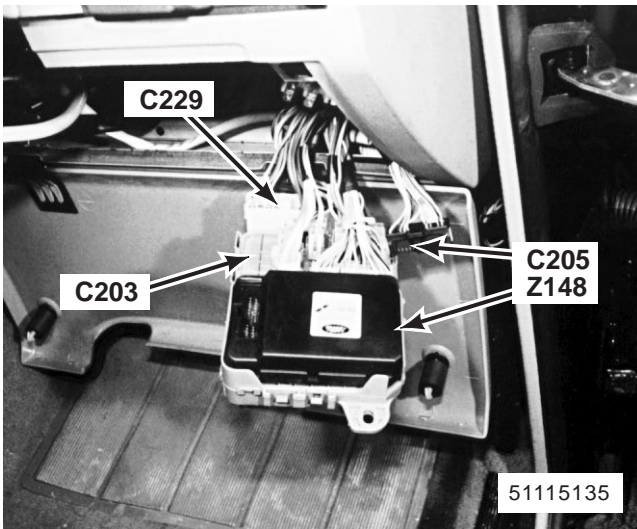

145. behind RH side of fascia rear of Fascia Fuse Box  
 Z148 Multi-Function Unit (MFU)  
 C203 (7-W)  
 C205 (24-B)  
 C229 (1-W)

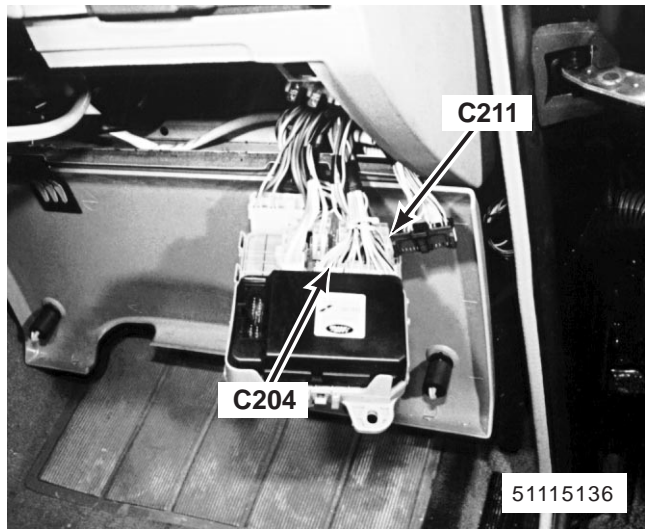

146. behind RH side of fascia rear of Fascia Fuse Box  
 C204 (24-W)  
 C211 (10-W)

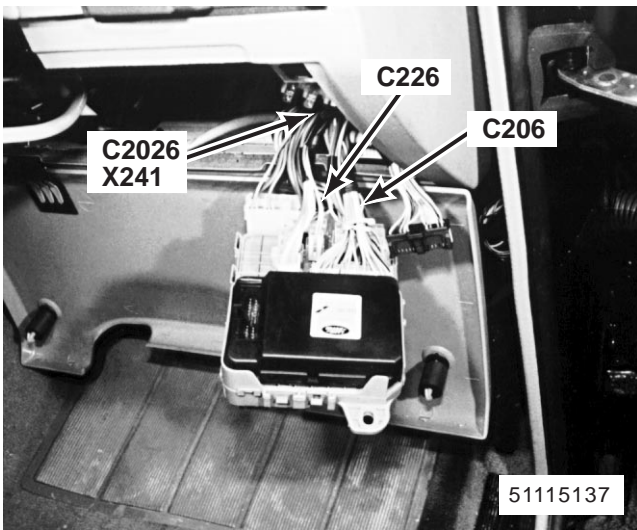

147. behind RH side of fascia rear of Fascia Fuse Box  
 X241 Saudi Junction Connector  
 C206 (4-W)  
 C226 (3-W)  
 C2062 (1-B)

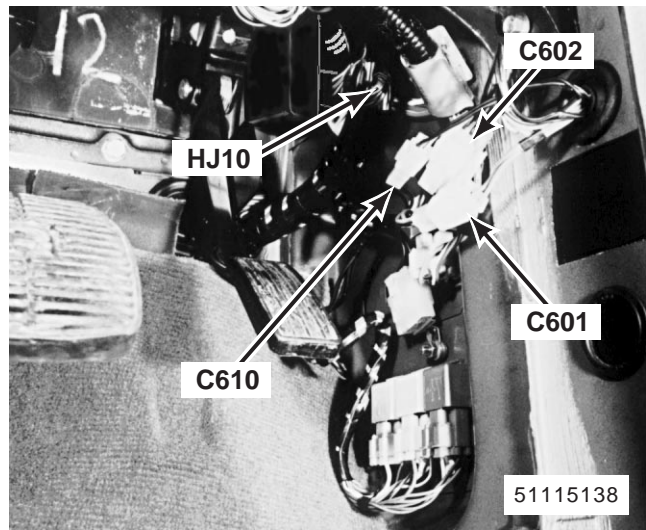

148. behind RH footwell trim panel  
 C601 (2-W)  
 C602 (13-W)  
 C610 (2-W)  
 HJ10 (20-B)

**Z5 ETM**

**DISCOVERY**

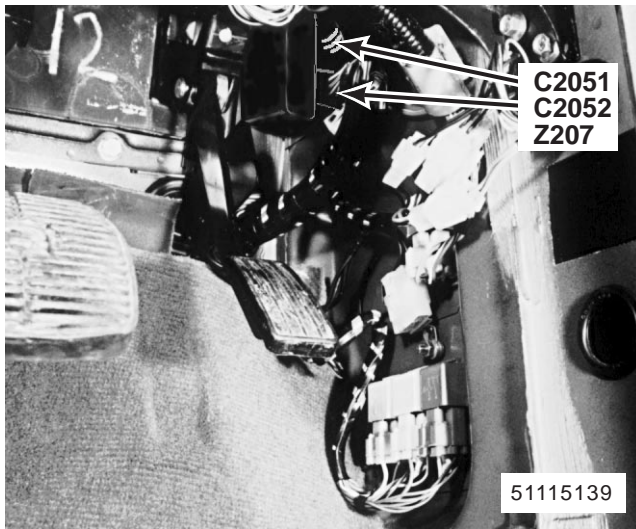

149. behind RH footwell trim panel  
 Z207 Multi-Function Relay Unit  
 C2051 (8-B)  
 C2052 (6-B)

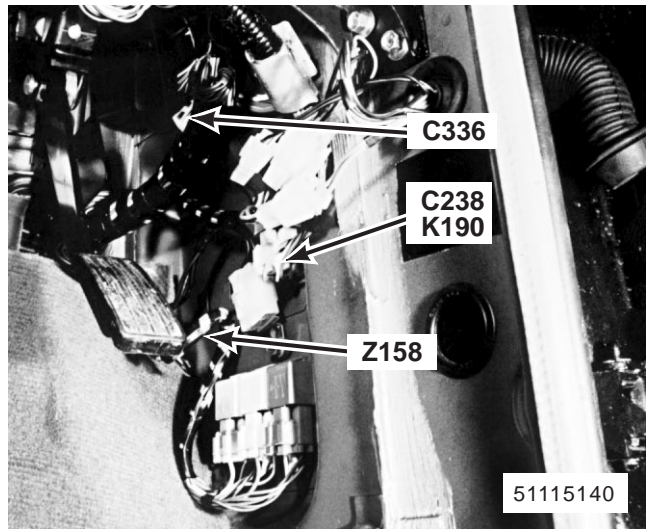

150. behind RH footwell trim panel  
 K190 Cooling Fan Relay  
 Z158 Starter Relay Diode  
 C238 (5-Y)  
 C336 (3-W)

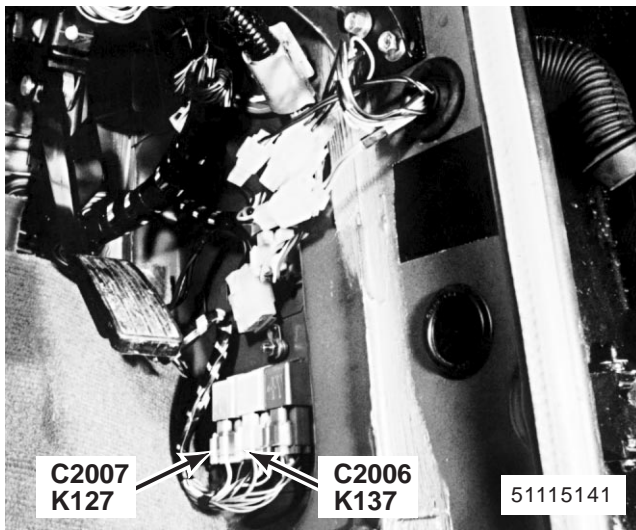

151. behind RH footwell trim panel  
 K127 Ignition Load Relay  
 K137 Starter Solenoid Relay  
 C2006 (5-Y)  
 C2007 (5-Y)

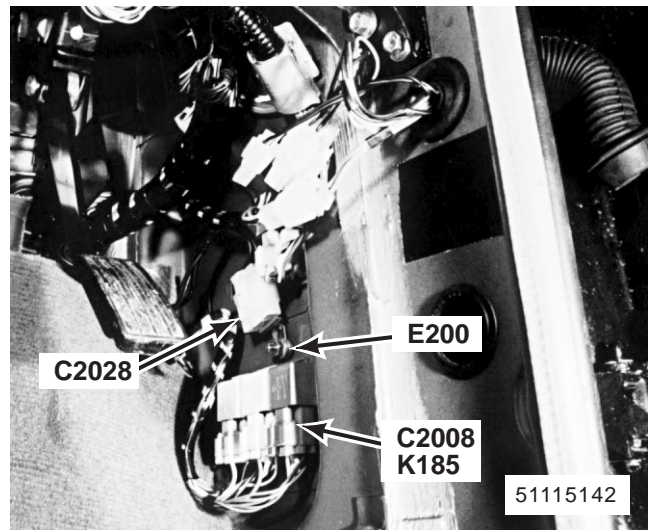

152. behind RH footwell trim panel  
 K185 Front Wiper Relay  
 C2008 (5-G)  
 C2028 (6-W)  
 E200

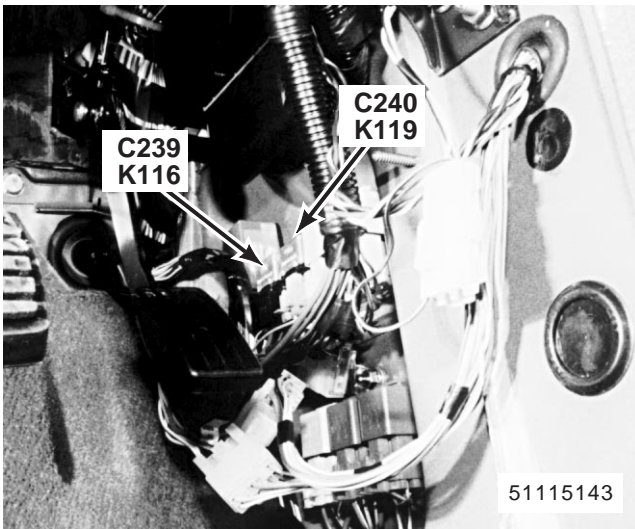

153. behind RH footwell trim panel (MFI-V8 shown; others similar)

K116 Engine Control Load Relay

K119 Fuel Pump Relay

C239 (5-U)

C240 (5-Y)

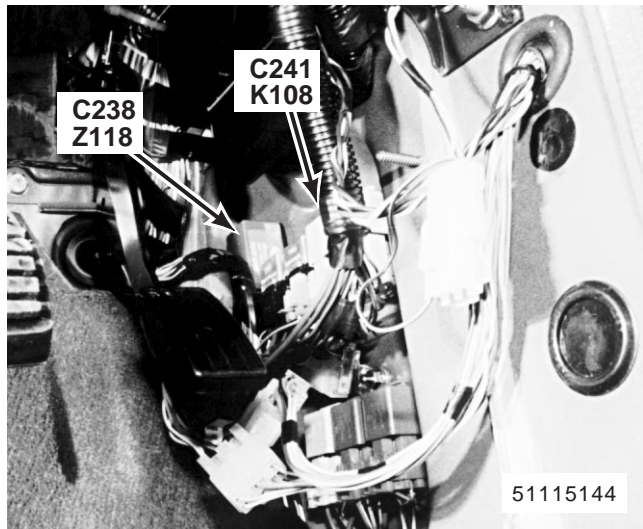

154. behind RH footwell trim panel (MFI-V8 shown; others similar)

K108 Compressor Clutch Relay

Z118 Fan Control Module

C238 (9-B)

C241 (5-Y)

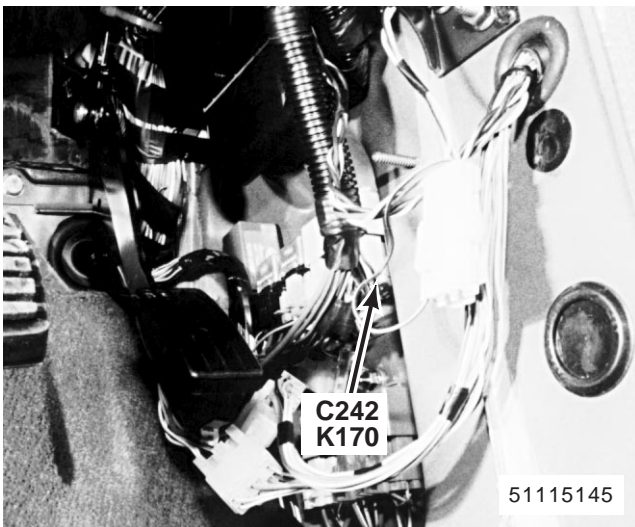

155. behind RH footwell trim panel (MFI-V8 shown; others similar)

K170 A/C Logic Relay

C242 (5-B)

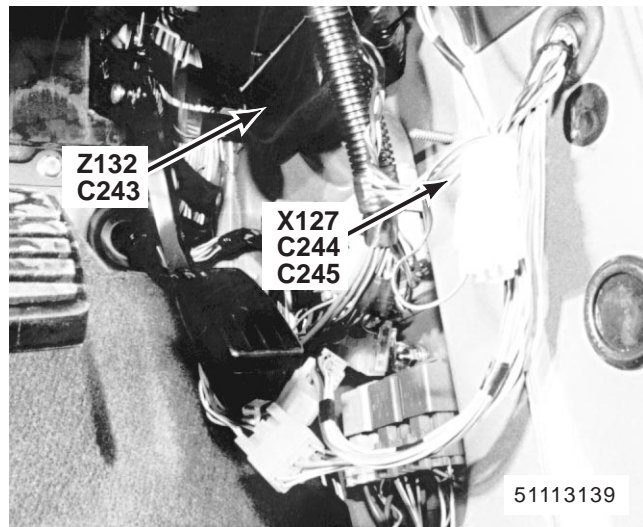

156. behind RH side of fascia

X127 Data Link Connectors

Z132 Engine Control Module (ECM)

C243 (40-B) MFI-V8

C243 (55-B) 300Tdi with EDC

C244 (5-W) MFI-V8

C245 (5-W) MFI-V8

C245 (4-W) 300Tdi with EDC



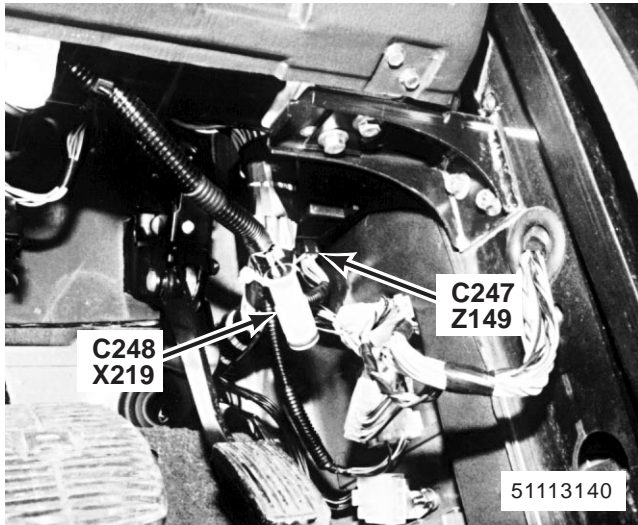

157. behind RH side of fascia  
 X219 Data Link Connector (EGR)  
 Z149 EGR Valve Control Module  
 C247 (16-B)  
 C248 (3-W)

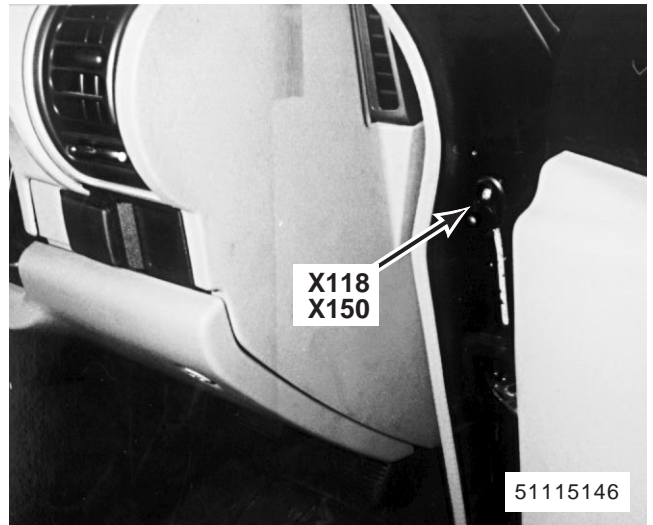

158. front of RH front door jamb (LH similar)  
 X118 Right Front Door Switch  
 X150 Left Front Door Switch

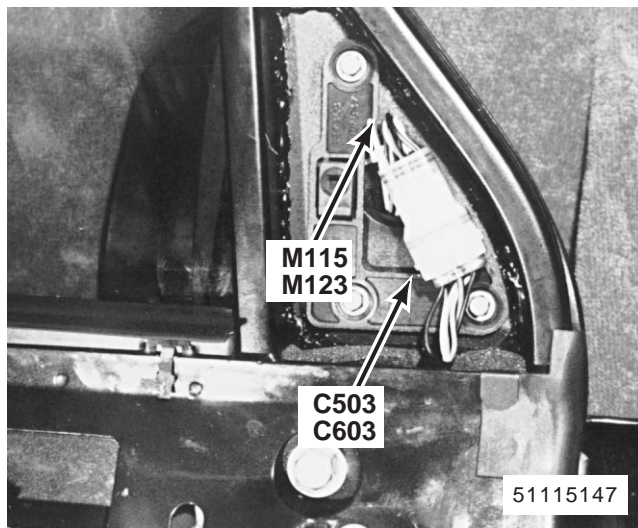

159. top front of LH front door (RH similar)  
 M115 Left Mirror Actuator  
 M123 Right Mirror Actuator  
 C503 (6-W) (Left)  
 C603 (6-W) (Right)

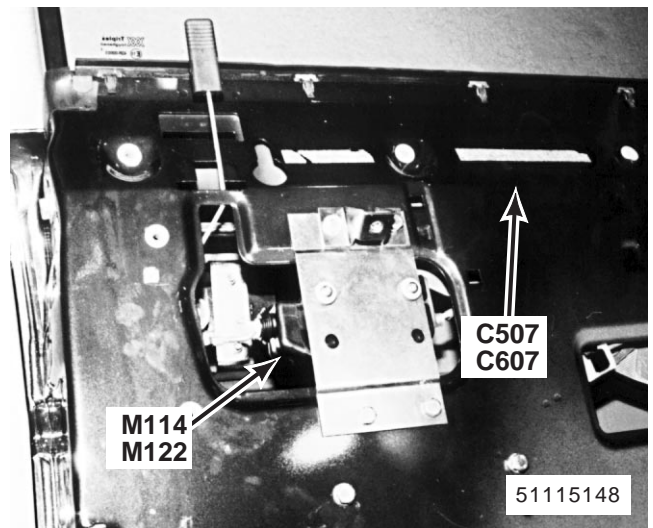

160. in rear of LH front door (RH similar)  
 M114 Left Front Door Lock Actuator  
 M122 Right Front Door Lock Actuator  
 C507 (2-W) (Left) Japan  
 C507 (4-W) (Left) Without Theft Alarm  
 C507 (6-W) (Left) With Theft Alarm  
 C607 (4-W) (Right) Without Theft Alarm  
 C607 (6-W) (Right) With Theft Alarm

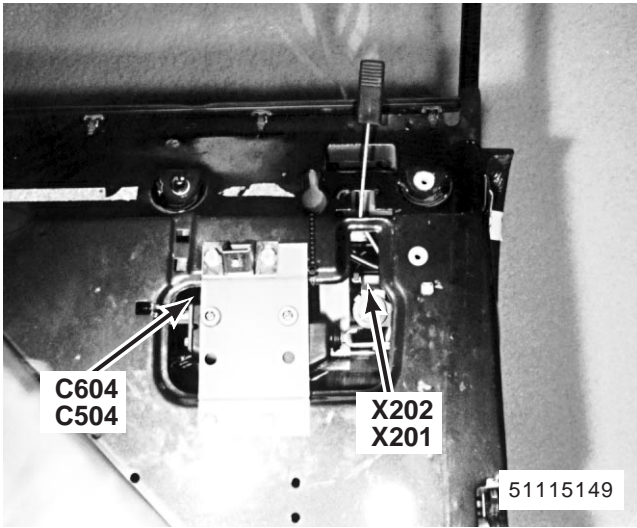

161. in top rear of RH front door (LH similar)  
 X201 Left Front Door Key Switch  
 X202 Right Front Door Key Switch  
 C504 (4-W) (Left)  
 C604 (4-W) (Right)

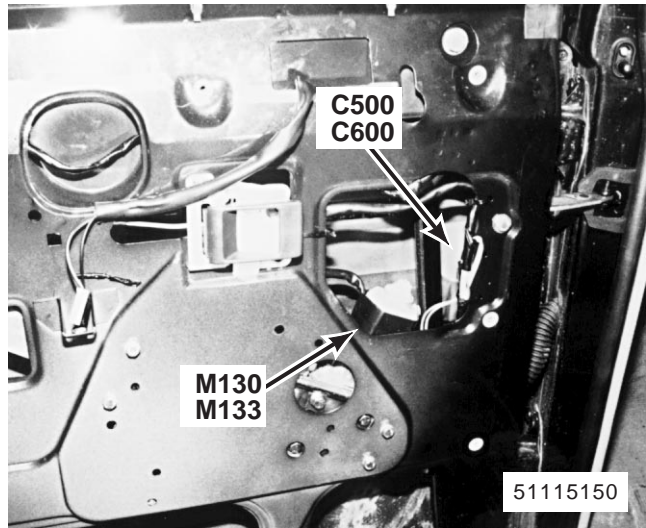

162. in front of LH front door (RH similar)  
 M130 Left Front Window Motor  
 M133 Right Front Window Motor  
 C500 (2-B) (Left)  
 C600 (2-B) (Right)

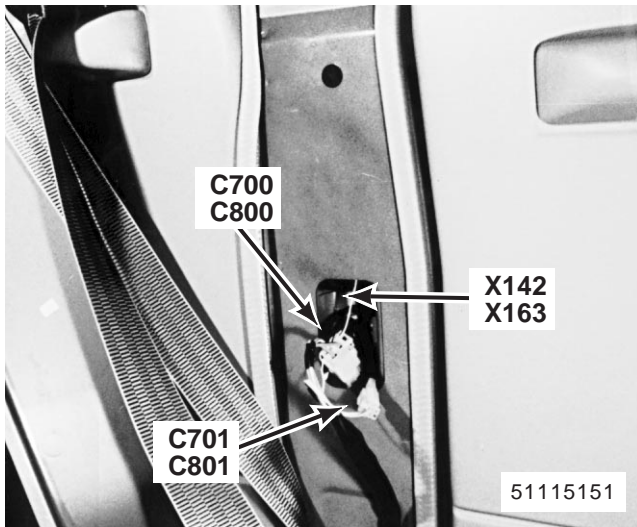

163. in lower part of LH B-post (RH similar)  
 X142 Left Rear Door Switch  
 X163 Right Rear Door Switch  
 C700 (3-W) (Left)  
 C800 (3-W) (Right)  
 C701 (2-W) (Left)  
 C801 (2-W) (Right)

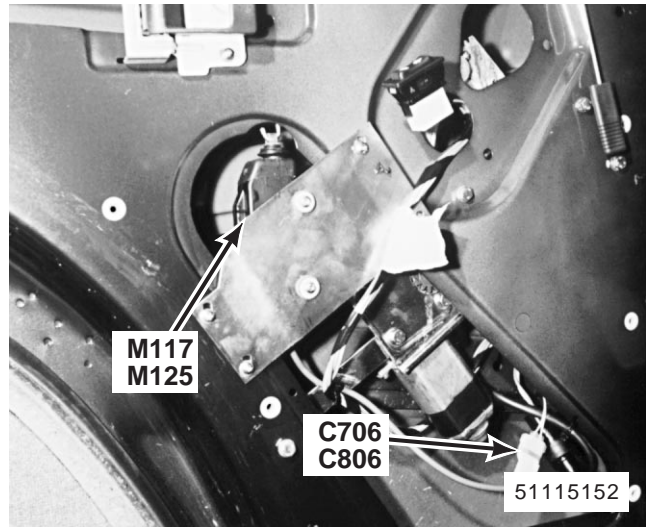

164. inside front of LH rear door (RH similar)  
 M117 Left Rear Door Lock Actuator  
 M125 Right Rear Door Lock Actuator  
 C706 (2-W) (Left)  
 C806 (2-W) (Right)

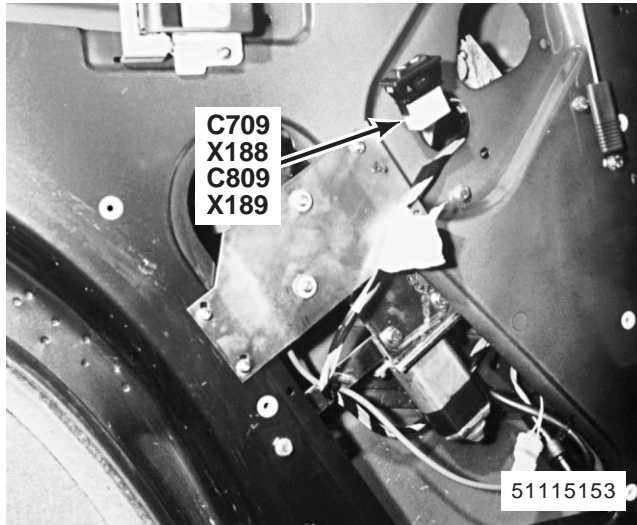

165. inside front of LH rear door (RH similar)  
 X188 Left Rear Window Door Switch  
 X189 Right Rear Window Door Switch  
 C709 (5-W) (Left)  
 C809 (5-W) (Right)

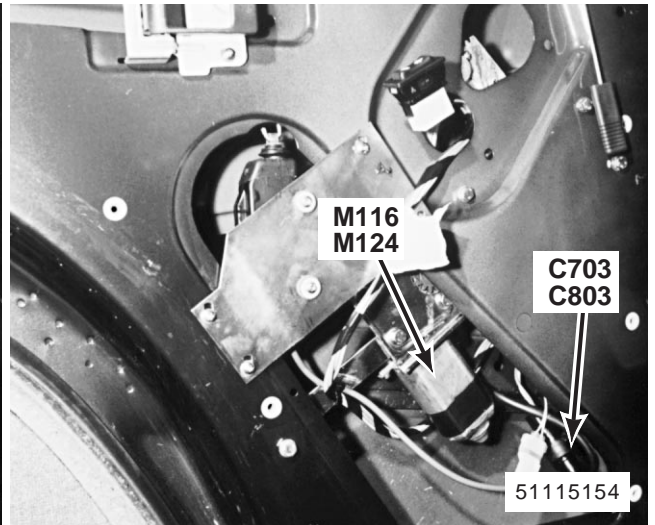

166. inside front of LH rear door (RH similar)  
 M116 Left Rear Window Motor  
 M124 Right Rear Window Motor  
 C703 (3-B) (Left)  
 C803 (3-B) (Right)

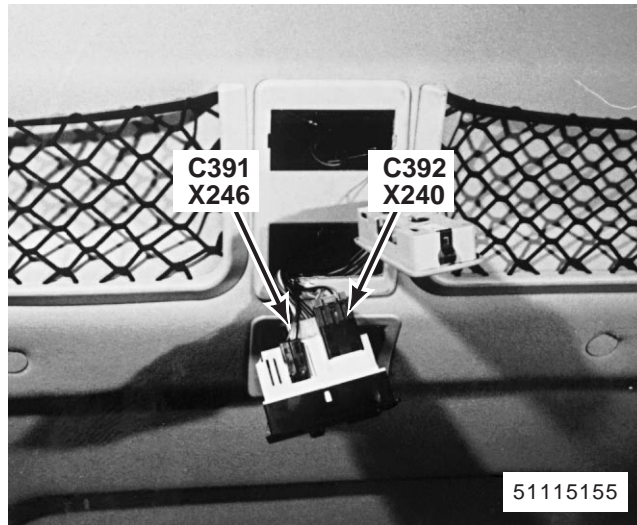

167. centre of roof  
 X240 Passenger's Rear A/C Switch  
 X246 Passenger's Rear Fan Speed Switch  
 C391 (5-W)  
 C392 (5-U)

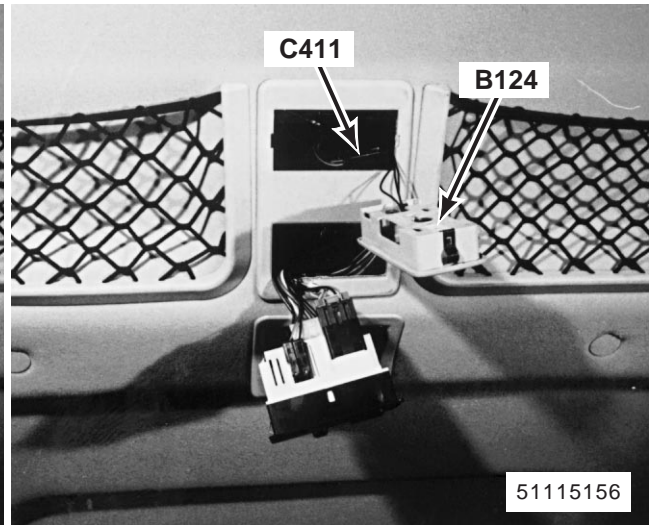

168. centre of roof  
 B124 Rear Interior Roof Lamp  
 C411 (4-B)



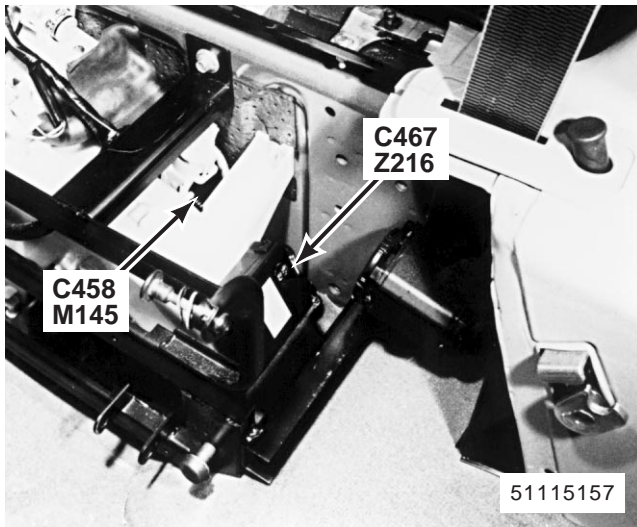

169. LH side of luggage compartment behind trim panel

M145 Rear Blower Motor

Z216 Rear A/C Switch Amplifier

C458 (2-B)

C467 (6-W)

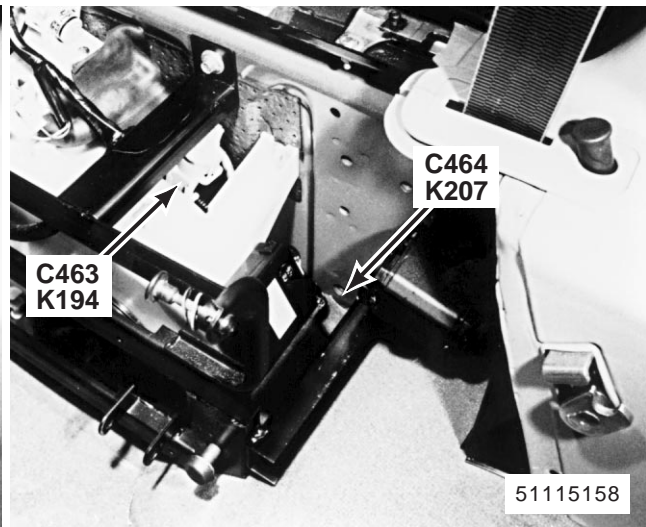

170. LH side of luggage compartment behind trim panel

K194 Rear A/C Control Relay

K207 Rear A/C Refrigerant Control Valve

C463 (4-W)

C464 (2-S)

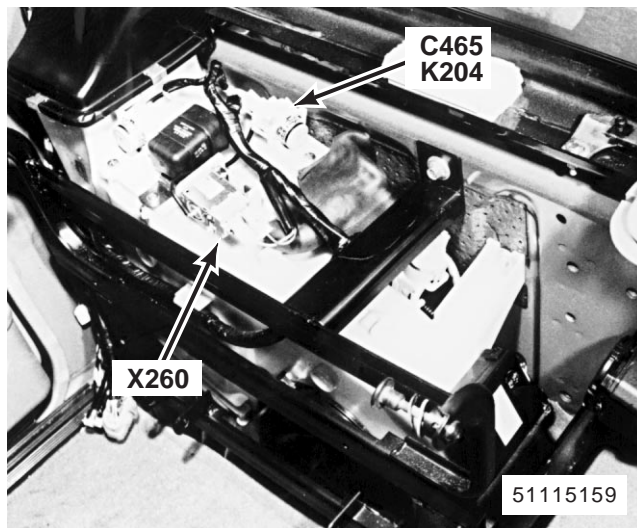

171. LH side of luggage compartment behind trim panel

X260 Rear A/C Evaporator Temperature Switch

K204 Rear A/C Illumination Relay

C465 (4-W)

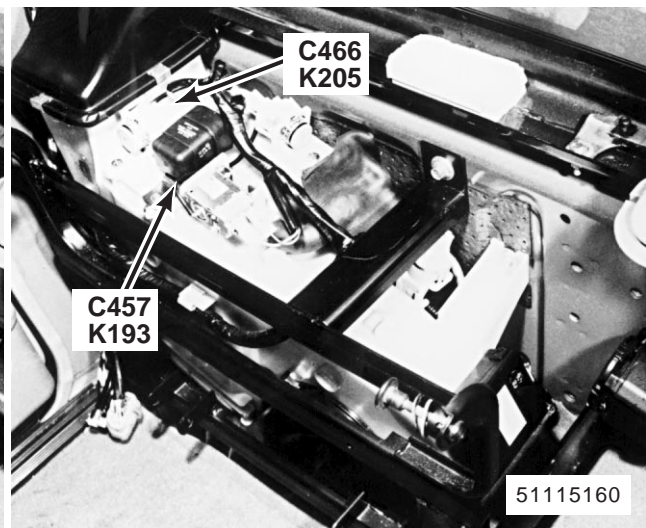

172. LH side of luggage compartment behind trim panel

K193 Rear Blower Motor Relay

K205 Rear A/C Fan Speed Relay

C457 (5-W)

C466 (4-W)

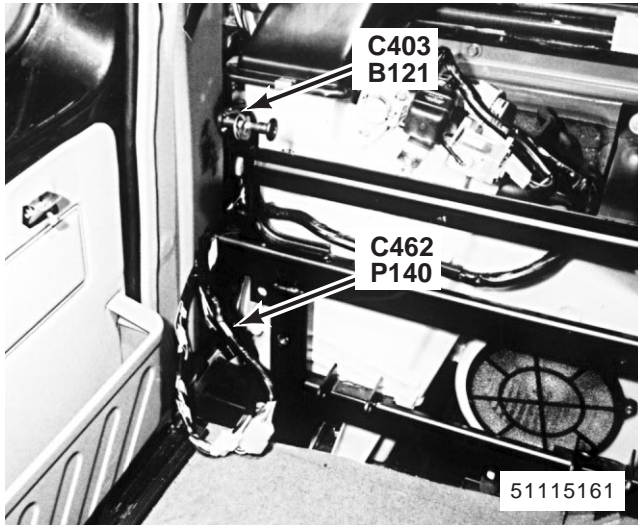

173. LH side of luggage compartment behind trim panel  
 B121 Left Rear Lamp Assembly  
 P140 Rear A/C Switch Amplifier In-Line Fuse  
 C403 (6-W)  
 C462 (2-B)

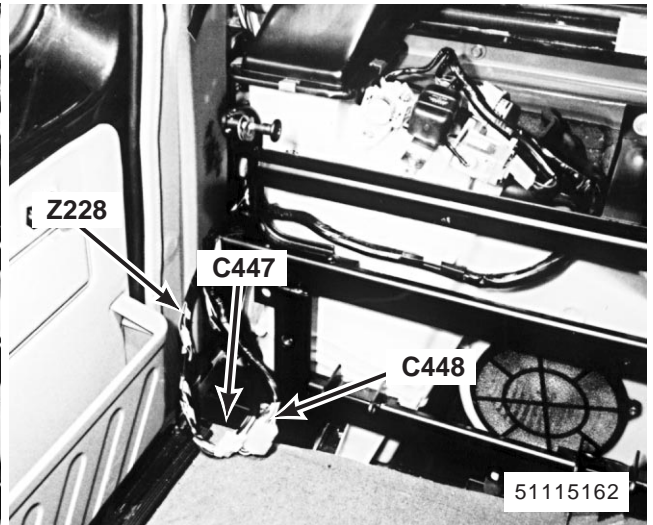

174. LH side of luggage compartment behind trim panel  
 Z228 Rear A/C Refrigerant Control Valve Diode  
 C447 (2-W)  
 C448 (16-W)

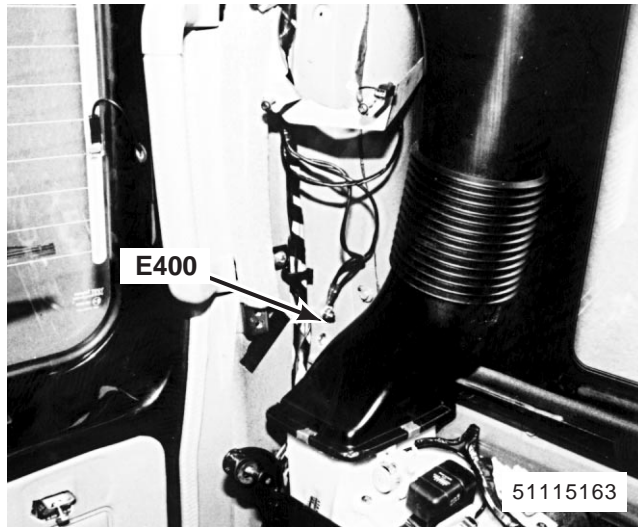

175. LH side of luggage compartment behind trim panel  
 E400



176. RH rear of luggage compartment behind trim panel  
 E401



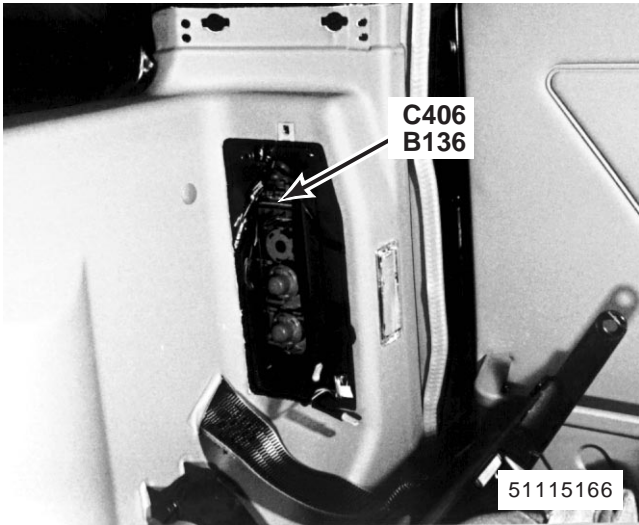

177. RH rear of luggage compartment behind trim panel  
 B136 Right Rear Lamp Assembly  
 C406 (6-W)

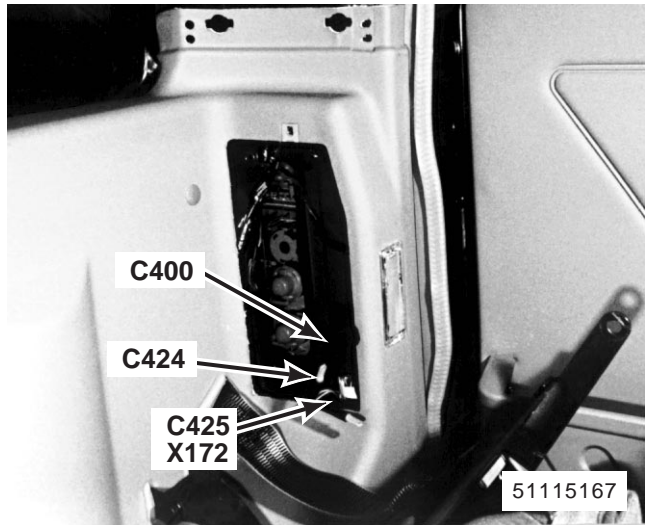

178. RH rear of luggage compartment behind trim panel  
 X172 Trailer Auxiliary Socket  
 C400 (7-B)  
 C424 (1-B)  
 C425 (1-B)

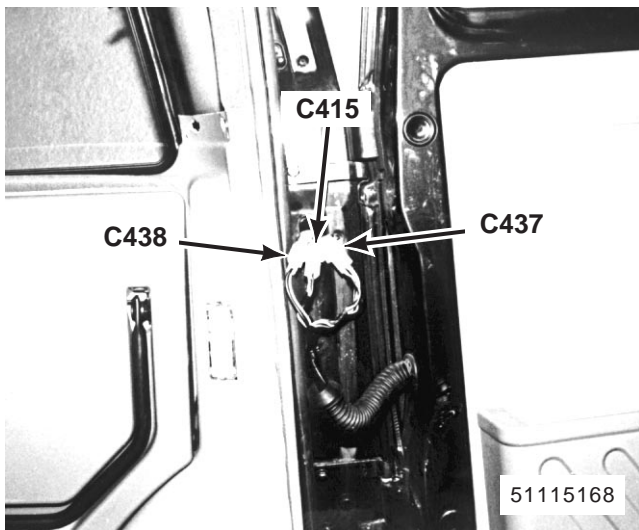

179. in RH side of tailgate door jamb  
 C415 (8-W)  
 C437 (6-W)  
 C438 (2-W)

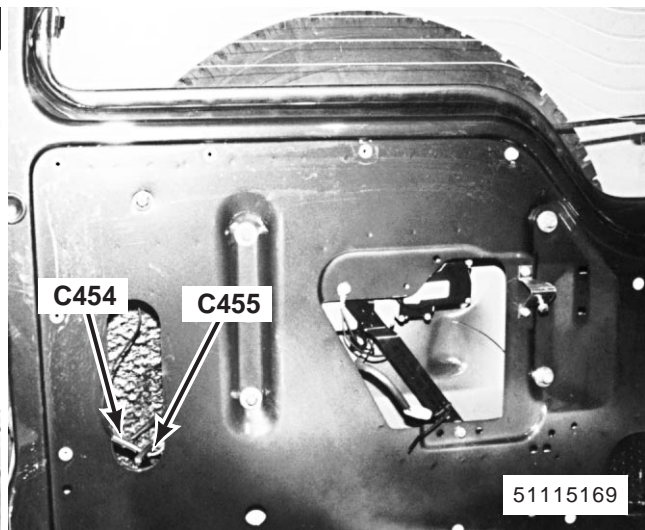

180. RH side of tailgate  
 C454 (1-B)  
 C455 (1-B)

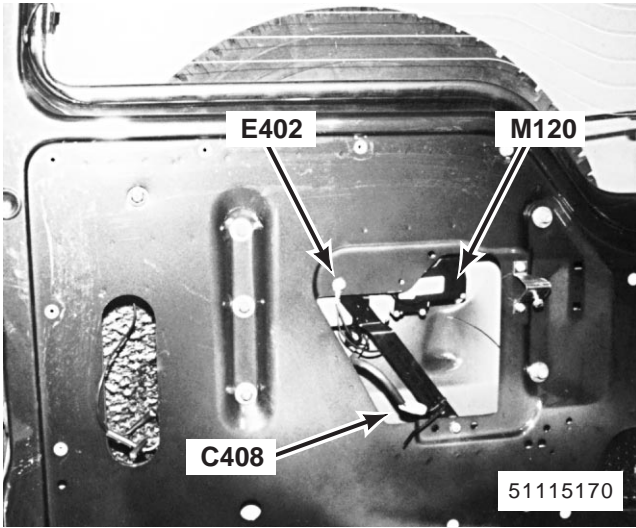

181. RH side of tailgate  
 M120 Rear Wiper Motor  
 C408 (4-W)  
 E402

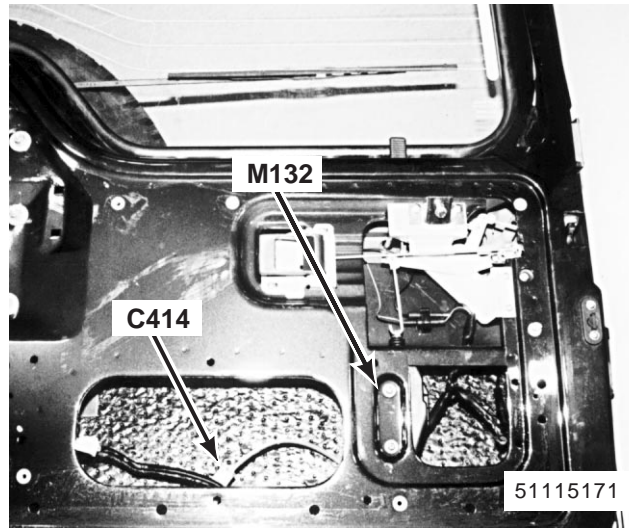

182. LH side of tailgate  
 M132 Tailgate Lock Actuator  
 C414 (2-W)

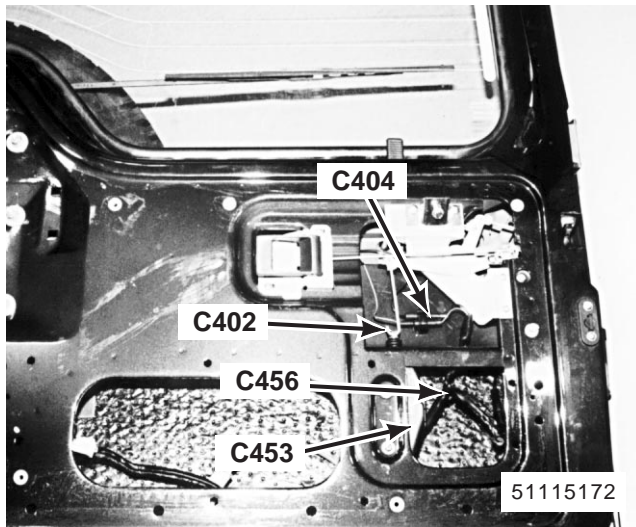

183. LH side of tailgate  
 C402 (1-B)  
 C404 (1-B)  
 C456 (1-B)  
 C453 (1-B)

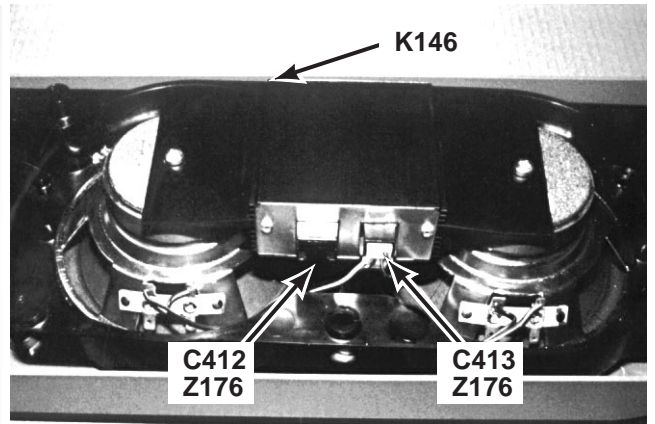

184. LH side of tailgate  
 K146 Subwoofer  
 Z176 Subwoofer Amplifier  
 C412 (6-W)  
 C413 (4-W)

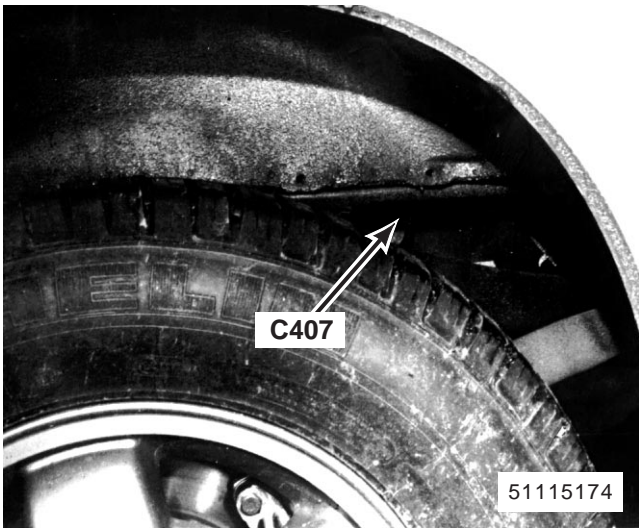

185. beneath LH rear of vehicle  
C407 (3-B)

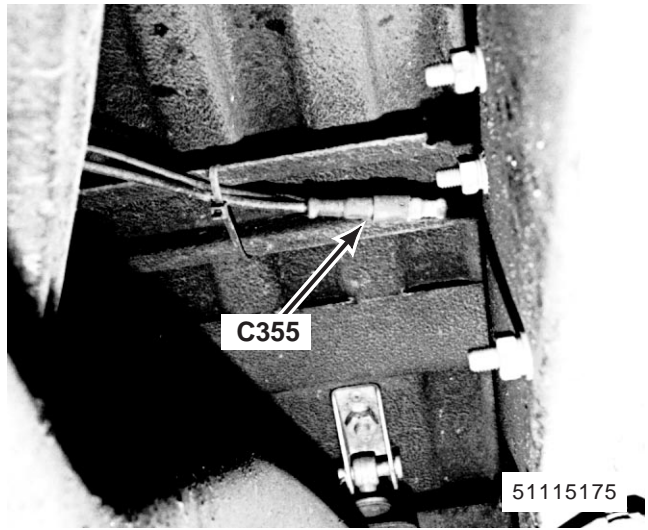

186. beneath LH rear of vehicle  
C355 (2-W)

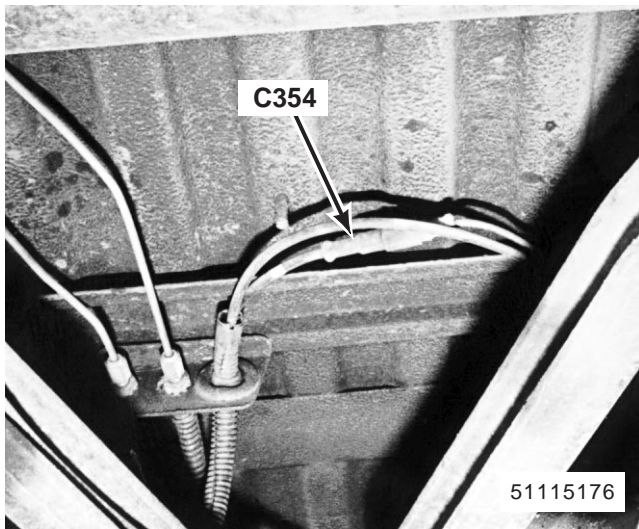

187. beneath RH rear of vehicle  
C354 (2-W)

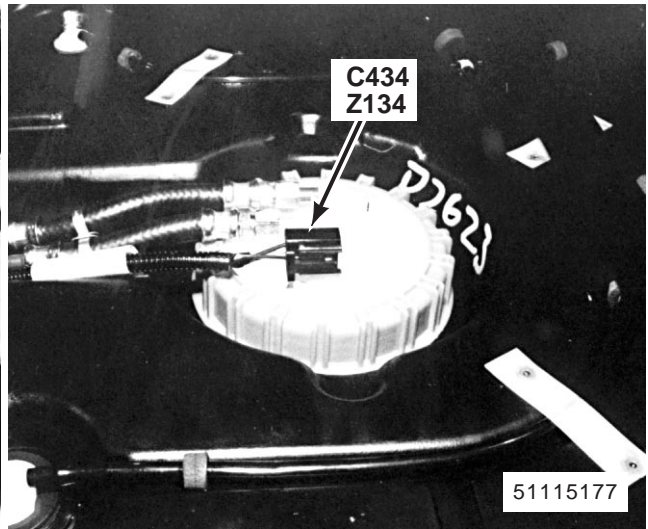

188. top of fuel tank  
Z134 Fuel Pump Module  
C434 (4-B)



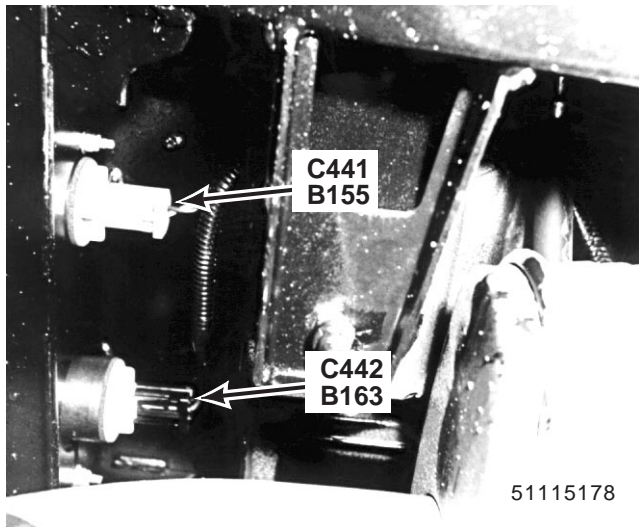

189. behind LH side of rear bumper  
 B155 Left Tail Lamp  
 B163 Left Rear Indicator Lamp  
 C441 (2-R)  
 C442 (2-B)

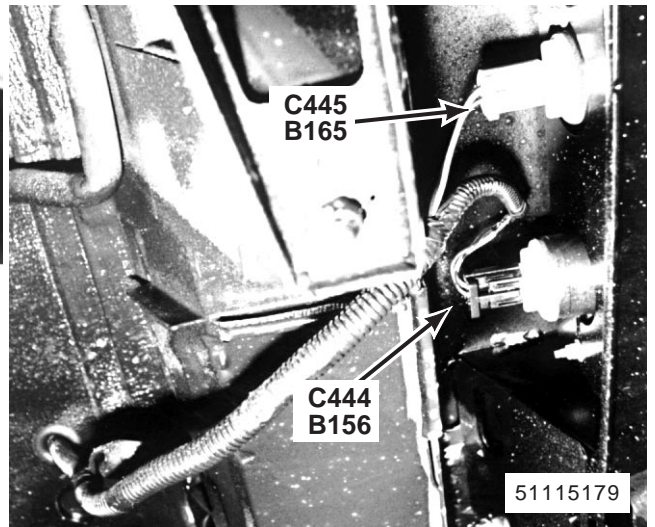

190. behind RH side of rear bumper  
 B165 Right Rear Indicator Lamp  
 B156 Right Tail Lamp  
 C444 (2-B)  
 C445 (2-R)

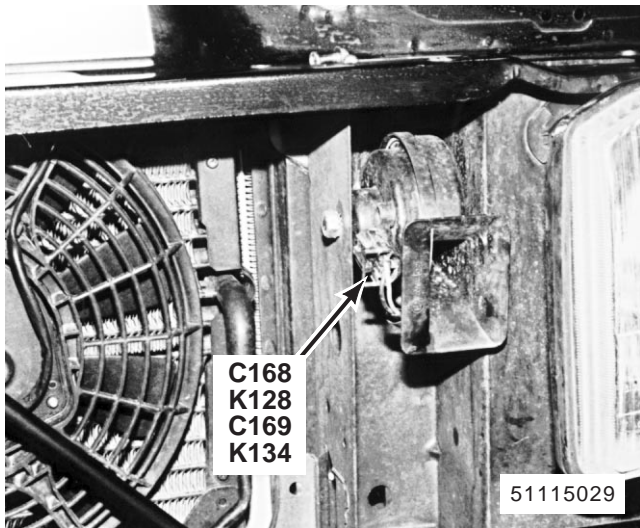

191. LH front of vehicle (RH similar)  
 K128 Left Horn  
 K134 Right Horn  
 C168 (2-B) (Left)  
 C169 (2-B) (Right)

**C100**

R030016

R030005



1	OK
2	PW
3	NLG

**C103**

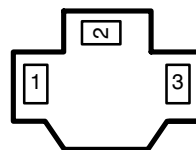

1	UO
2	UB
3	B

**C101**

LC00100A

R040005

LC00103A

R030005

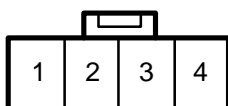

1	OS	3	-
2	NG	4	PN

**C104**

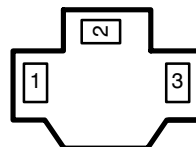

1	US
2	UK
3	B

LC00101A

R130001

**C105**

LC00104A

R130002

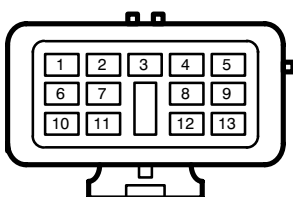

1	BU	6	SB	11	BO/BY
2	BR	7	BK	12	RY
3	GN	8	BLG	13	-
4	GY	9	YB		
5	B	10	BY		

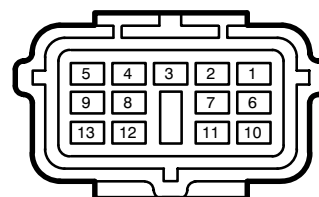

1	BO	6	SB	11	BO
2	BR	7	BK	12	-
3	GN	8	BLG	13	-
4	GY	9	BY		
5	B	10	BY		

LC00105C

LC00105C

### C109

R020002



1	RB
2	B

### C113

R030025

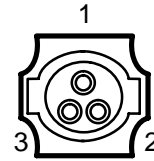

1	WO
2	CORE
3	B

### C110

LC00109C  
R020002

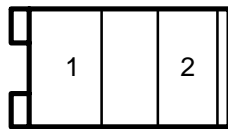

1	RO
2	B

### C114

LC00113A  
R020023

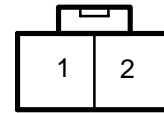

1	NK
2	NW

R030025  
**C112**

LC00110C

LC00114A  
R040001

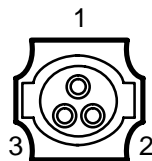

1	WO
2	CORE
3	B

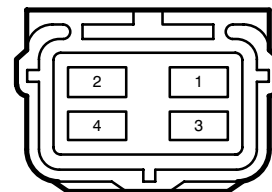

1	UY	3	B
2	UW	4	NU

LC00112C

LC00112C

R030019

R020007

**C115**

**C124**

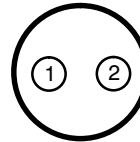
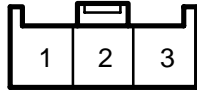

1	NP
2	NP
3	NO

1	GR
2	B

LC00115C

LC00124C

R020037

R020025

**C120**

**C125**

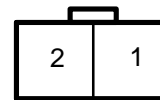
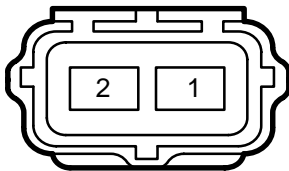

1	B
2	LGS

1	NR
2	B

LC00120A

LC00125C

R020007

R030012

**C123**

**C127**

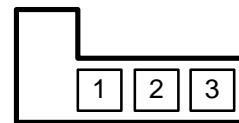
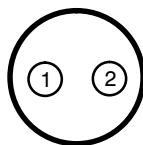

1	GW
2	B

1	LGK
2	B
3	-

LC00123C

LC00127C

## C129

R130002

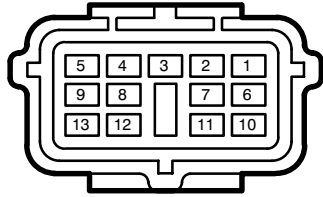

1	SR	6	B	11	SW
2	SY	7	SU	12	SP
3	-	8	SN	13	B
4	SG	9	B		
5	SK	10	B		

LC00129C

R020007

## C130

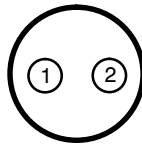

1	G
2	G

LC00130A

R040019

## C132

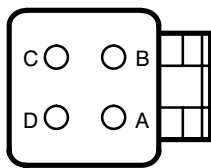

A	O	C	GW
B	US	D	RG

LC00132C

## C131

R020007

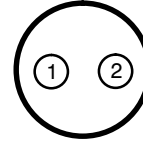

1	G
2	G

LC00131A

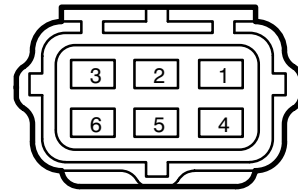

1	OS	4	OU
2	NK	5	-
3	KU	6	OG

R060016

LC00132C



R060004

R050007

**C133**

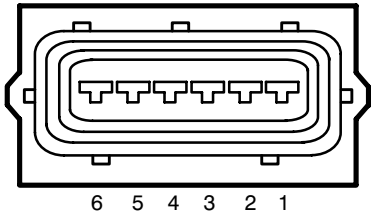

1	-	4	-
2	RB	5	NO
3	UG	6	UR

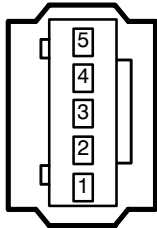

1	YB	4	B
2	UG	5	-
3	UR		

LC00133C

LC00133C

R020038

R020038

**C134**

**C136**

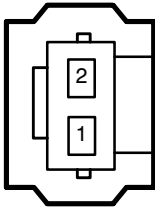

1	YU/NK
2	NO/YU

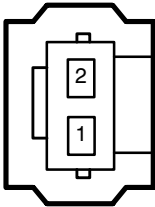

1	YU/NK
2	NO/YW

LC00134C

LC00136C

R020038

R020038

**C135**

**C137**

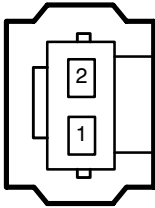

1	YW/NK
2	NO/YG

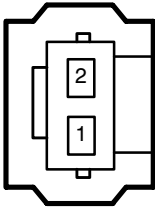

1	YW/NK
2	NO/YB

LC00135C

LC00137C

R020038

### C138

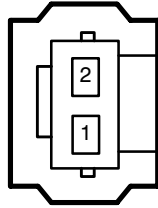

1	YU
2	NO

R020038

### C141

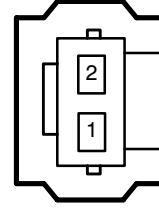

1	YW
2	NO

LC00138C  
R020038

### C140

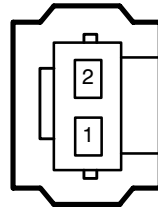

1	YU
2	NO

LC00141A  
R020038

### C142

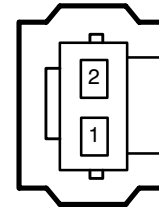

1	WN
2	-

LC00140A  
R020009

### C144

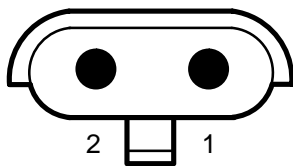

1	WP
2	SY

LC00142C  
R020045

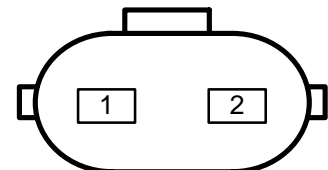

1	NK
2	RS

LC00144C

LC00144C

**C145**

R020011

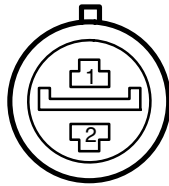

1	BG
2	B

LC00145A  
R020020

**C146**



1	BP
2	B

LC00146A

R030022

**C149**

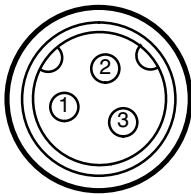

1	RB
2	R
3	Y

LC00149C

**C148**

R030002

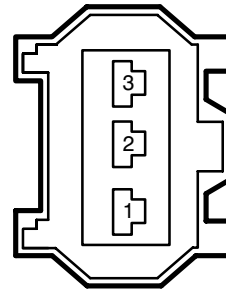

1	U
2	-
3	R

LC00148A

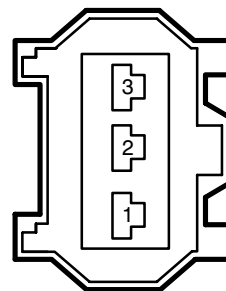

1	KP
2	GY
3	KB

LC00149C

R020038

R060018

## C150

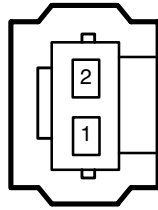

1	RB/YU
2	SW/KB

## C159

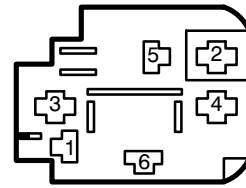

1	WR	4	B
2	BY	5	NO
3	WG	6	YB

LC00150C

LC00159A

R020038

R020038

## C152

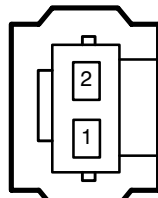

1	GU/RB/KB
2	B/GU/KG

## C165

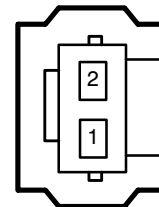

1	WG
2	BO

LC00152C

LC00165A

R020006

R020054

## C166

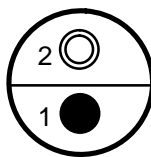

1	B
2	BLG

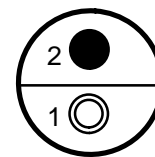

1	B
2	PB

LC00166C

LC00166C

R030023

R020037

**C167**

**C170**

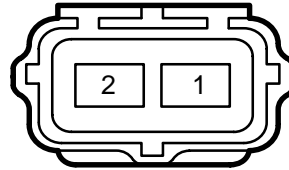
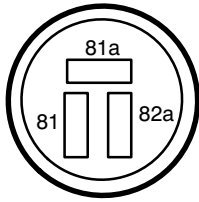

81	BY
81A	BR
82A	WU

1	B
2	LGB

LC00167A

LC00170A

R020037

R030003

**C168**

**C171**

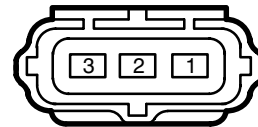
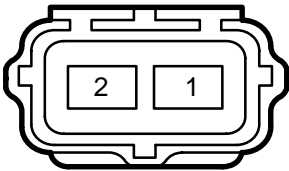

1	B
2	PG

1	WP
2	-
3	WP

LC00168A

LC00171A

R020037

R020015

**C169**

**C173**

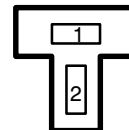
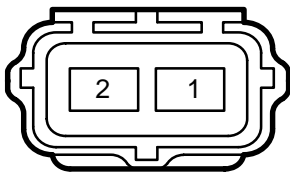

1	B
2	PG

1	LGR
2	B

LC00169A

LC00173A

R020037

**C177**

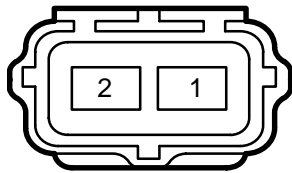

1	NP
2	NO

R020031

**C181**

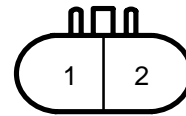

1	YB
2	ON

LC00177G

R020037

**C178**

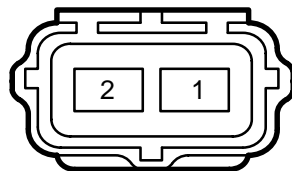

1	B
2	PO

LC00181C

R020011

**C182**

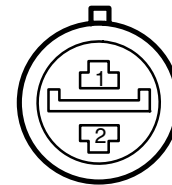

1	BN
2	B

LC00178A

R020036

**C179**

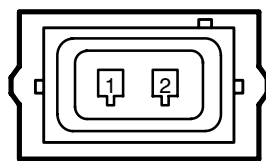

1	YR
2	B

LC00182A

R020011

**C183**

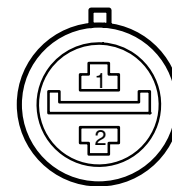

1	BN
2	B

LC00179C

LC00183A

R030002

R030002

**C190**

**C191**

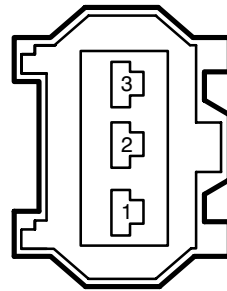
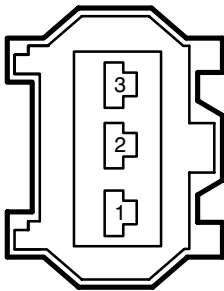

1	B
2	UY
3	RB

1	B
2	UY
3	RB

LC00190C

LC00191C

R040011

R040017

**C195**

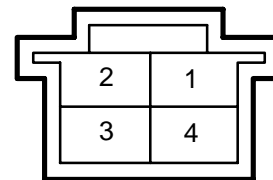
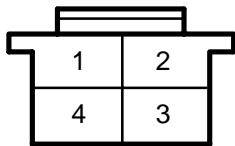

1	WS	3	WG
2	B	4	WP

1	O	3	N
2	K	4	B

LC00195C

LC00195C

R020038

R030002

**C196**

**C197**

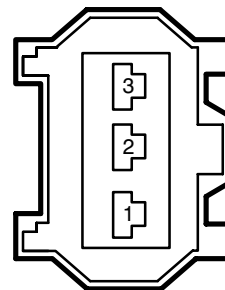
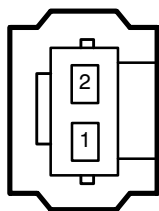

1	NB
2	B

1	Y
2	B
3	B

LC00196C

LC00197C

R060016

## C198

R030028

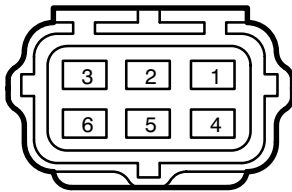

1	NK	4	YG
2	YB	5	YU
3	WB	6	-

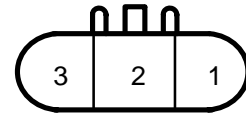

1	WO
2	NO
3	NS

LC00198C

R080018

## C199

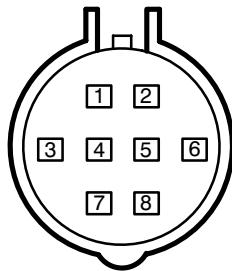

1	GO	5	NO
2	R	6	WP
3	GK	7	WS
4	B	8	-

LC00198C  
R030002

## C1001

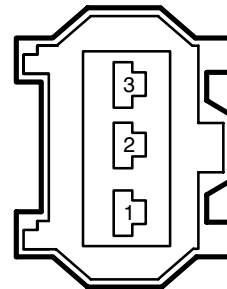

1	YU
2	YG
3	B

LC00199C

R020038

## C1000

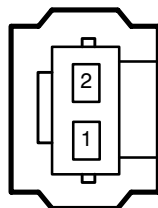

1	KO/KS
2	KB/B

LC01001C  
R030002

## C1002

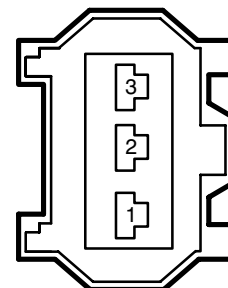

1	-
2	NK
3	YU

LC001000C

LC01002C



R030002

R020038

**C1003**

**C1005**

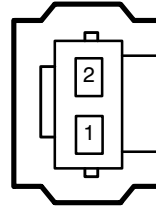
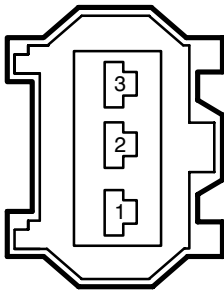

1	-
2	NK
3	WB

1	KB
2	LGS

LC01003C

LC01005C

R020038

R030024

**C1004**

**C1006**

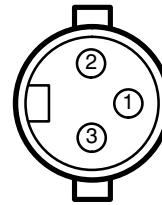
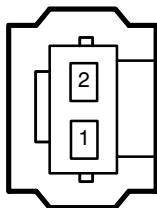

1	WU
2	UP

1	KB
2	BO
3	

LC01004C

LC01006C

R360001

**C1007**

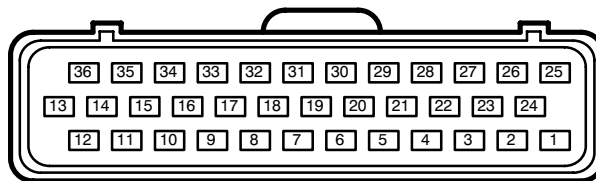

1	YU	7	UY	13	-	19	BS	25	YU	31	UP
2	KU	8	GY	14	B	20	UP	26	YG	32	WU
3	OS	9	KP	15	BG	21	RS	27	OU	33	KG
4	YN	10	BO	16	KO	22	OG	28	NK	34	YU
5	-	11	WG	17	LGS	23	WB	29	B	35	BN
6	BP	12	-	18	UW	24	YB	30	KB	36	U

LC01007C

## C1008

R180005

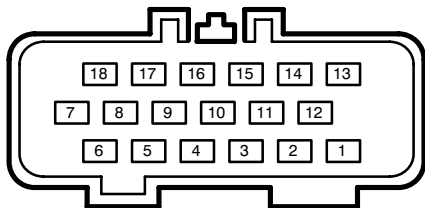

1	-	6	-	11	B	16	-
2	-	7	-	12	-	17	-
3	-	8	-	13	-	18	WB
4	-	9	-	14	-		
5	B	10	-	15	-		

## C1011

R020011

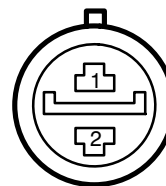

1	US/BR
2	B

## C1009

LC01008C

R020037

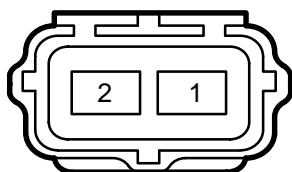

1	B/GR
2	GR/B

## C1012

LC01011C

R020011

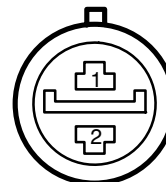

1	BR
2	B

## C1010

LC01009F

R020037

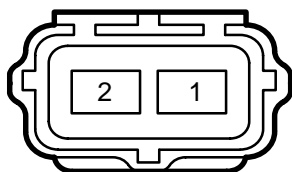

1	B
2	GW

## C1013

LC01012C

R020007

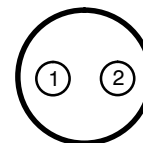

1	RB
2	B

LC01010F

LC01013C

R020007

**C1014**

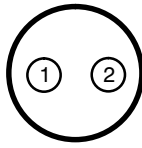

1	RO
2	B

R020003

**C1016**

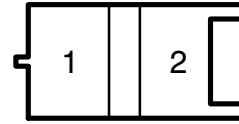

1	B
2	PB

LC01014C  
R040011

**C1015**

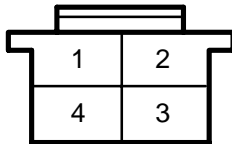

1	O	3	N
2	K	4	B

LC010016C

LC010015C

R040018

**C200**

R040015

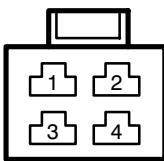

1	NP	3	R
2	U	4	-

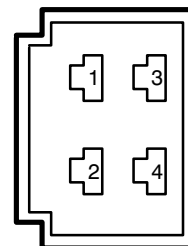

1	NP	3	R
2	U	4	-

LC00200C

LC00200C

R070011

## C201

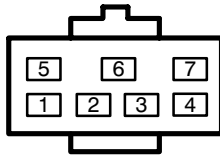

1	R	5	UW
2	NG	6	NP
3	UR	7	PO
4	U		

LC00201A

R240004

R240001

## C202

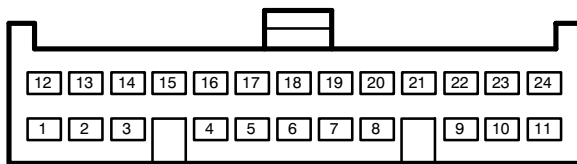

1	B	7	WLG	13	GR	19	P
2	UR	8	LGP	14	WP	20	PU
3	GR	9	LGN	15	GW	21	PO
4	LGG	10	ULG	16	WY	22	NG
5	-	11	LGB	17	RW	23	BR
6	UW	12	RLG	18	UW	24	P

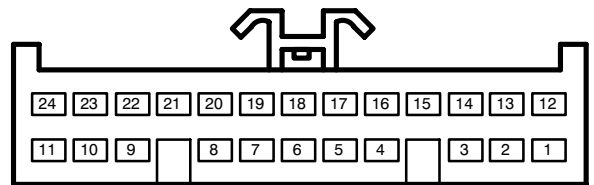

1	B	7	WLG	13	GR	19	PN
2	UR	8	LGP	14	WP	20	PW
3	GS	9	LGN	15	GW	21	PO
4	LGG	10	ULG	16	WY	22	NG
5	-	11	LGB	17	RW	23	BR
6	UW	12	RLG	18	UW	24	P

LC00202C

R070005

LC00202C

R240004

## C203

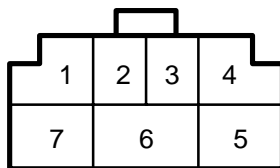

1	UR	5	LGW
2	U	6	W
3	R	7	NP
4	W		

LC00203A

## C204

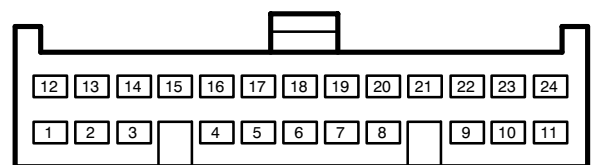

1	LGP	7	GY	13	-	19	G
2	LGN	8	RB	14	GW	20	WR
3	WN	9	LGP	15	RB	21	GO
4	P	10	GS	16	GR	22	UO
5	GLG	11	US	17	-	23	RO
6	-	12	UB	18	-	24	UK

LC00204C

R240003

R100007

**C205**

**C207**

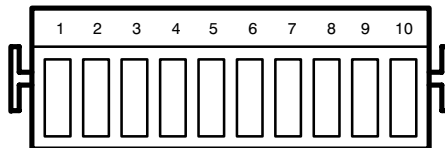
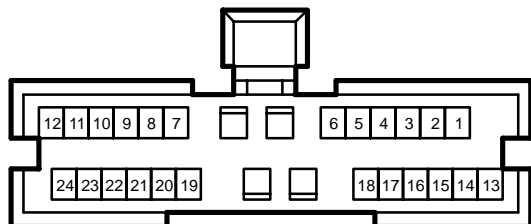

1	PU	7	RW	13	LGB	19	-
2	G	8	WLG	14	Y	20	-
3	-	9	LGG	15	OU	21	WP
4	PU	10	BK	16	LGS	22	NS
5	PW	11	B	17	UB	23	NP
6	-	12	WR	18	PW	24	-

1	LG	4	G	6	LGU	8	B
2	BS	5	WS	7	LG	9	LGG
3	UW					10	BLG

LC00205G

LC00207C

R040014

R180004

**C206**

**C208**

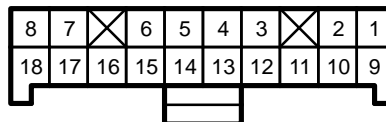
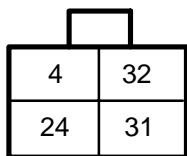

4	R	31	B
24	UW	32	OS

1	G	6	-	11	-	16	-
2	-	7	GR	12	UW	17	B
3	-	8	GW	13	UR	18	BO
4	RO	9	-	14	WN		
5	LG	10	-	15	-		

LC00206A

LC00208C

R200002

R200007

**C209**

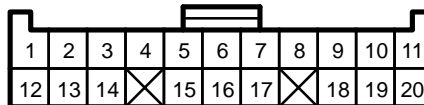
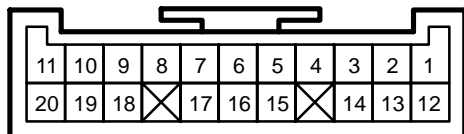

1	RN	6	BY	11	BP	16	G
2	RS	7	SW	12	WY	17	YK
3	Y	8	BU	13	LGO	18	YK
4	RW	9	BK	14	GO	19	-
5	BR	10	BN	15	GLG	20	BS

1	RN	6	PO	11	BP	16	G
2	RS	7	SW	12	WY	17	YK
3	YK	8	BU	13	LGO	18	YK
4	RW	9	BK	14	GO	19	YK
5	BR	10	BN	15	GLG	20	BS

LC00209G

LC00209G

R100004

## C211

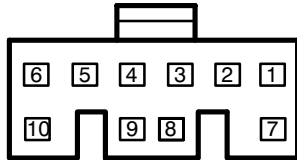

1	-	4	GR	6	GW	8	-
2	-	5	RB	7	RO	9	ND
3	-					10	-

LC0100211C

R140002

## C212

R140007

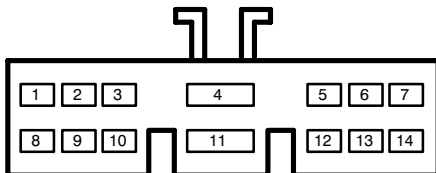

1	BO	6	B	11	NG
2	BY	7	SCR	12	UW
3	BG	8	BG	13	WG
4	PN	9	BY	14	W
5	R	10	BU		

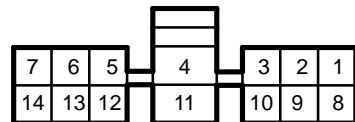

1	BO	6	B	11	NG
2	BY	7	SCR	12	YO
3	BG	8	BG	13	WG
4	PN	9	PY	14	YU
5	R	10	BU		

LC00212C

R030026

## C214

LC00212C

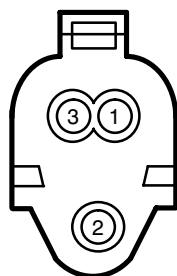

1	RN
2	RO
3	B

LC00214A

R240005

R240002

C215

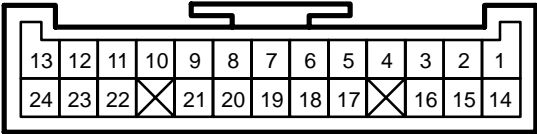
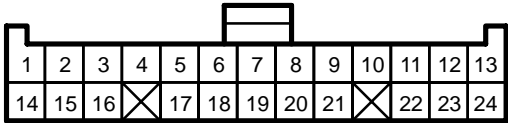

1	PN	7	-	13	KO	19	BLG
2	WS	8	UY	14	OU	20	LGN
3	G	9	PN	15	GU	21	-
4	-	10	WR	16	-	22	LGK
5	LGP	11	RY	17	LGS	23	-
6	GB	12	BG	18	BO	24	NY

1	PN	7	-	13	KO	19	BLG
2	WS	8	UY	14	OU	20	LGN
3	G	9	PN	15	GU	21	-
4	-	10	WR	16	-	22	LGK
5	LGP	11	RY	17	LGS	23	-
6	GP	12	NP	18	BO	24	NY

LC00215C

LC00215C

R070009

R070010

C216

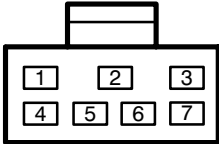
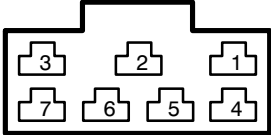

1	NLG	5	BR
2	WP	6	BG
3	PW	7	WG
4	NR		

1	NLG	5	BN/NG
2	WP	6	BG
3	PW	7	WG
4	NR		

LC00216C

LC00216C

R200005

R200006

C217

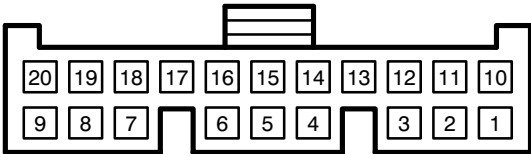
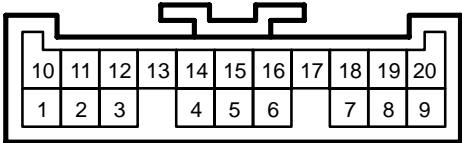

1	GU	6	B	11	YB	16	NG
2	WS	7	-	12	BY	17	NY
3	WN	8	PY	13	LGP	18	WG
4	BP	9	YK	14	GP	19	PB
5	WU	10	OB	15	RS	20	GW

1	GU	6	B	11	YB	16	NG
2	WS	7	-	12	BY	17	NY
3	WN	8	-	13	GP	18	WG
4	BP	9	YK	14	GP	19	PB
5	WU	10	OB	15	RS	20	GW

LC00217G

LC00217G

R080012

## C218

R080011

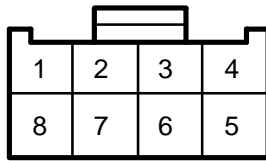

1	WU	5	-
2	BY	6	B
3	PW	7	P
4	WY	8	PY

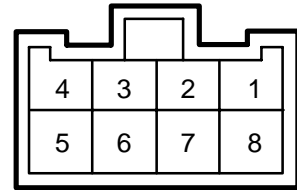

1	WU	5	-
2	-	6	B
3	PW	7	P
4	WY	8	P

LC00218C

R030017

## C220

LC00218C

R100007

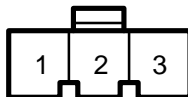

1	NW
2	LG
3	-

## C222

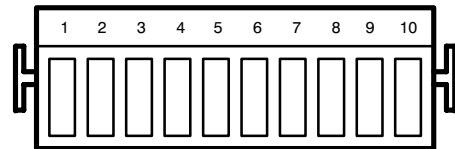

1	RS	4	-	6	-	8	GU
2	LG	5	WN	7	RN	9	RN
3	KO					10	B

LC00220A

R100007

## C221

LC00222C

R050005

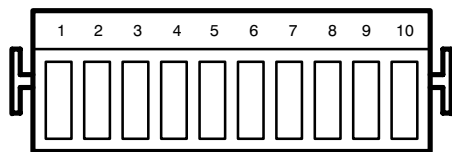

1	B	4	YK	6	BO	8	LG
2	BR	5	NY	7	PO	9	WR
3	GB					10	-

## C223

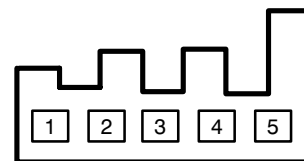

1	G	4	-
2	-	5	S
3	P		

LC00221C

LC00223A



R060008

**C224**

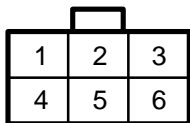

1	B	4	GS
2	NLG	5	RLG
3	ULG	6	-

R080015

**C228**

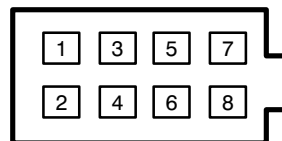

1	BK	5	BP
2	BN	6	GLG
3	SW	7	BU
4	B	8	-

LC00224A

R030019

**C226**



1	-
2	WY
3	LGW

LC00228C

R080017

**C230**

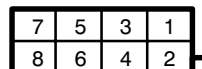

1	-	5	UY
2	B	6	RN
3	U	7	LGO
4	P	8	B

LC00226A

R040007

**C227**

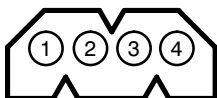

1	GP	3	WR
2	GO	4	WS

LC00230C

LC00227C

R090002

R050001

## C238

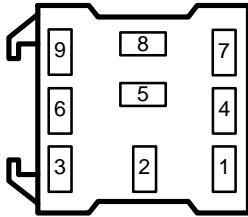

1	-	4	BR	7	-
2	NO	5	BG	8	GW
3	-	6	B	9	PB

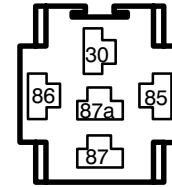

30	NG	87	US
85	BP	87A	-
86	WG		

LC00238C

LC00238C

R050001

R050001

## C239

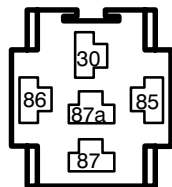

30	NLG	87	NO
85	UR	87A	NO
86	NO		

## C241

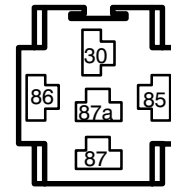

30	NG	87	WG/BS
85	BS	87A	BG
86	WG		

LC00239C

LC00241C

R050001

R050001

## C240

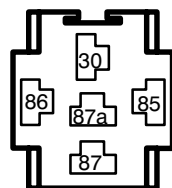

30	PW	87	WP
85	UP	87A	WO
86	WG		

## C242

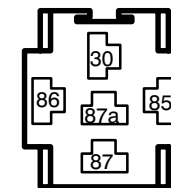

30	WG/BN/NG/YG	87	GY/B/BG/WG
85	WG/YB	87a	-
86	YB/WG/G		

LC00240A

LC00242C

R40001

**C243**

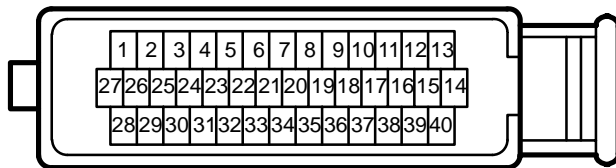

1	RG	7	GU	13	YU	19	WG	25	RB	31	BS	37	-
2	NO	8	PY	14	B	20	R	26	GW	32	SW	38	NK
3	Y	9	WLG	15	NO	21	GY	27	BS	33	BS	39	WU
4	B	10	RS	16	UP	22	UR	28	US	34	OB	40	B
5	SB	11	YW	17	SY	23	CORE	29	O	35	UG		
6	YK	12	UR	18	WK	24	CORE	30	K	36	BG		

LC00243C

R550001

**C243**

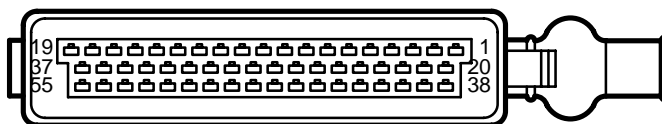

1	WP	8	-	15	UR	22	-	29	YK	36	KS	43	-	50	-
2	WP	9	BS	16	NO	23	-	30	-	37	WG	44	YG	51	YU
3	W	10	NS	17	NO	24	-	31	LGP	38	UG	45	-	52	YB
4	RS	11	-	18	B	25	WS	32	-	39	GK	46	-	53	GU
5	NB	12	B	19	B	26	GP	33	WP	40	-	47	Y	54	YG
6	SR	13	B	20	-	27	WK	34	UR	41	-	48	-	55	WG
7	-	14	R	21	GO	28	-	35	WS	42	WLG	49	-		

LC00243C

R050012

**C244**

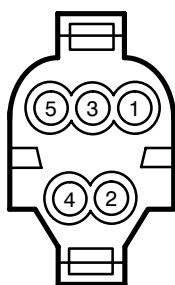

1	BS	4	-
2	-	5	-
3	-		

LC00244A

R050013

R040013

## C245

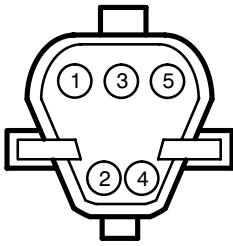

1	WK	4	WLG
2	-	5	BS
3	-		

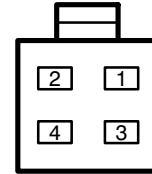

1	WK	3	B
2	WLG	4	NO

LC00245C

LC00245C

R020033

R030024

## C246

## C248

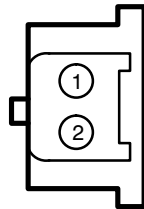

1	BS
2	SB

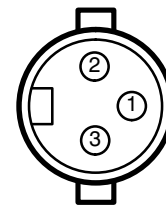

1	KB
2	WLG
3	WK

LC00246A

LC00248A

R160003

R050002.03

## C247

## C249

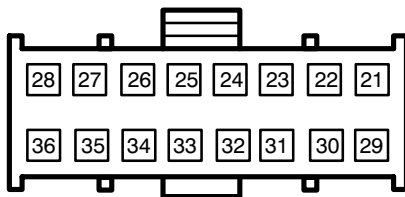

21	KB	25	R	29	B	33	WK
22	-	26	GU	30	-	34	RU
23	-	27	-	31	-	35	RB
24	BO	28	WG	32	WLG	36	WS

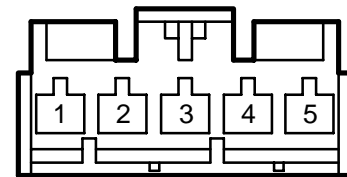

1	GLG	4	LGS
2	RN	5	B
3	-		

LC00247A

LC00249A

R050002.00

**C250**

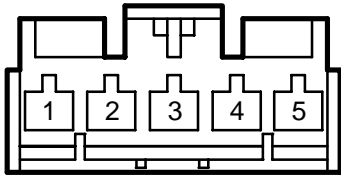

1	GLG	4	OU
2	RN	5	B
3	-		

LC00250A

R060017

R060016

**C252**

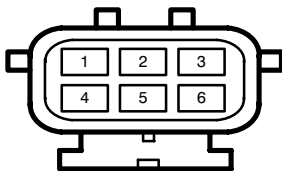

1	P	4	B
2	LGP	5	G
3	S	6	G

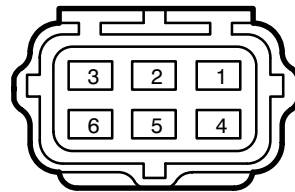

1	P	4	B
2	LG	5	G
3	S	6	G

LC00252C

R060007

LC00252C

R100011

**C259**

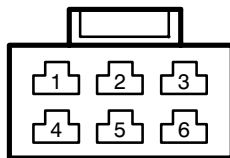

1	B	4	RN
2	UY	5	RO
3	-	6	-

**C260**

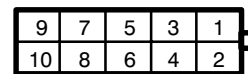

1	R	4	B	6	B	8	B
2	B	5	Y	7	U	9	R
3	G					10	B

LC00259C

LC00260C

R050002.02

R100008

### C262

### C267

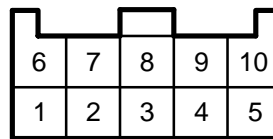
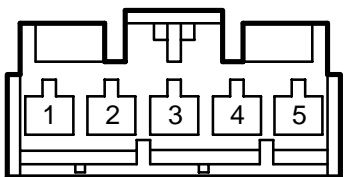

1	GLG	4	WY
2	RN	5	B
3	-		

1	LGN	4	GW	6	GO	8	LGP
2	GR	5	-	7	PN	9	RN
3	LGG					10	B

LC00262A

LC00267C

R050002.01

R080016

### C263

### C268

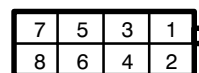
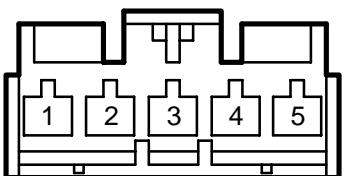

1	UR	4	RY
2	RN	5	B
3	-		

1	NY/BG	5	B/BW
2	U/BU	6	BN
3	UG/BK	7	BY
4	RG/BR	8	BO

LC00263A

LC00268C

R050002.02

R020027

### C264

### C269

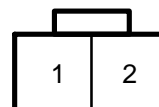
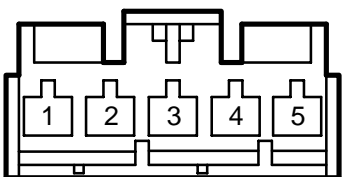

1	BO	4	B
2	RN	5	BG
3	-		

1	P
2	RW

LC00264C

LC00269C

R040008

R060001

**C270**

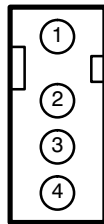

1	PN	3	RN
2	B	4	LG

**C274**

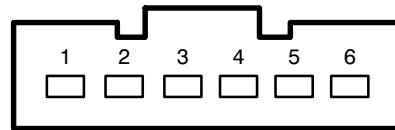

1	BO	4	O
2	BO	5	K
3	OB	6	P

LC00270C

LC00274G

R230001

**C277**

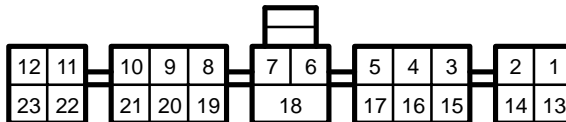

1	LGO	7	-	13	GP	19	GW
2	GR	8	GLG	14	RY	20	RO
3	PU	9	NG	15	BN	21	-
4	GP	10	WP	16	WB	22	-
5	O	11	PW	17	RB	23	-
6	K	12	GN	18	NP		

LC00277C

R230002

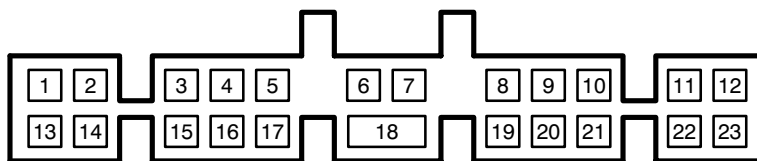

1	LGO	7	-	13	GB	19	GW
2	GR	8	GLG	14	RY	20	RO
3	PU	9	NG	15	BN	21	RO
4	GP	10	WP	16	WB	22	-
5	O	11	PW	17	RB	23	-
6	K	12	GN	18	NP		

LC00277C

R050001

R050001

### C279

### C282

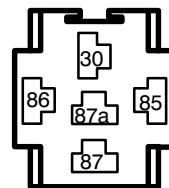
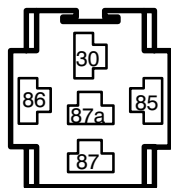

30	PU	86	PU
85	BK	87	GR
87A	GW		

30	NW	86	LG
85	B	87	LGW
87A	-		

LC00279A

LC00282A

R050001

R050001

### C280

### C283

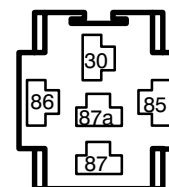
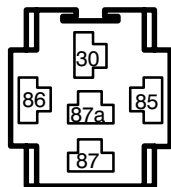

30	P	86	P
85	OB	87	PB
87A	-		

30	PN	86	PO
85	PN	87	PG
87A	-		

LC00280C

LC00283A

R050001

R150001

### C281

### C284

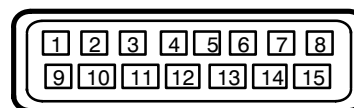
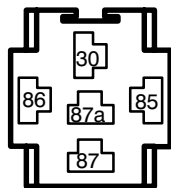

30	NG	86	GLG
85	NP	87	GLG
87A	B		

1	WU	6	BY	11	YK
2	-	7	BR	12	-
3	RW	8	B	13	-
4	UW	9	PG	14	-
5	GP	10	WY	15	-

LC00281C

LC00284A



R040010

R080003

**C285**

**C288**

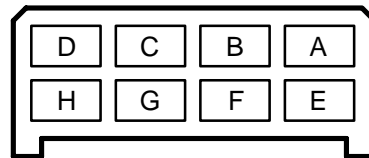
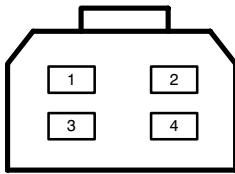

1	B	3	GLG
2	BW	4	UW

A	PN	E	WK
B	SB	F	SR
C	B	G	SK
D	PS	H	SU

LC00285G

LC00288A

R040010

R050001

**C286**

**C292**

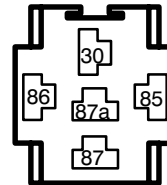
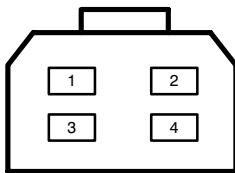

1	B	3	GLG
2	BW	4	UE

30	NG	86	BP
85	GW	87	BN
87A	-		

LC00286G

LC00292A

R100005

R050001

**C287**

**C293**

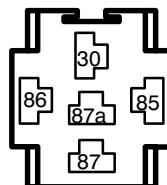
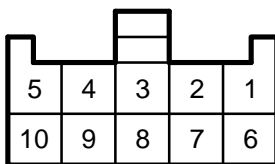

1	BK	4	WG	6	BR	8	-
2	-	5	BU	7	PW	9	BS
3	LGP					10	-

30	UR	86	BS
85	NP	87	NO
87A	-		

LC00287C

LC00293G

R030007

R030004

## C298



1	-
2	B
3	R

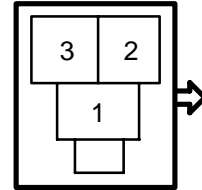

1	-
2	WB
3	R

LC00298A

R050001

LC00298A

R050001

## C299

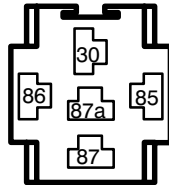

30	WR	86	B
85	UW	87	B
87A	-		

## C2001

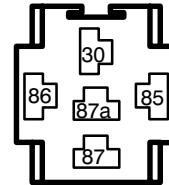

30	WY	86	BR
85	YB	87	SB
87A	-		

LC00299G

R050001

LC02001A

R020032

## C2000

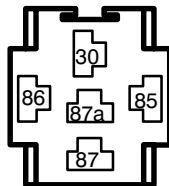

30	WP	86	WP
85	BK	87	RB
87A	-		

## C2005

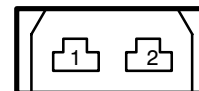

1	PY
2	PG

LC02000A

LC02005A

**C2006**

R050001

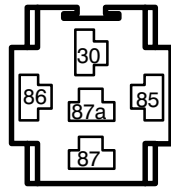

30	NW	86	BO
85	WR	87	NR
87A	-		

**C2009**

R040012

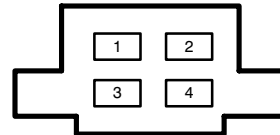

1	-	3	LGN
2	GW	4	GR

**C2007**

LC02006A

R050001

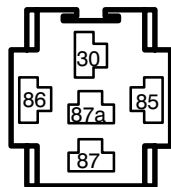

30	NG	86	B
85	LGP	87	WG
87A	-		

**C2010**

LC02009A

R060005

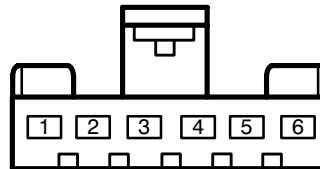

1	WY	4	RW
2	-	5	PO
3	UW	6	-

**C2008**

LC02007C

R050001

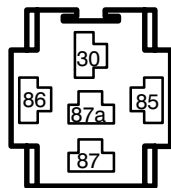

30	LGP	86	NS
85	GS	87	GS
87A	NLG		

**C2011**

LC02010A

R060013

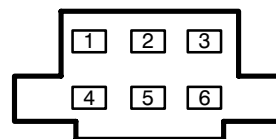

1	WLG	4	-
2	-	5	-
3	B	6	-

LC02008A

LC02011A

## C2012

R080006

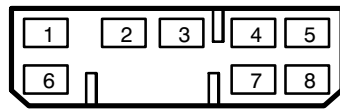

1	PW	5	PN
2	P	6	OW
3	WP	7	-
4	BR	8	-

## C2015

R080009

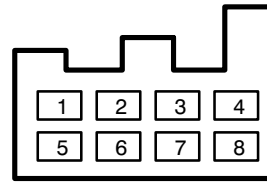

1	GS	5	LGB
2	LGG	6	LGB
3	ULG	7	-
4	RLG	8	GS

## C2013

LC02012A

R040001

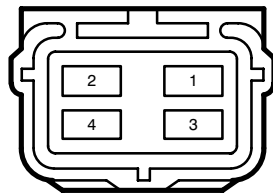

1	PN	3	B
2	PW	4	WP

## C2021

LC02015A

R050001

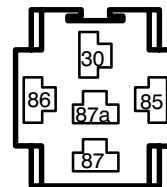

30	WS/WU	86	WS
85	BY/B	87	PW
87A	PY		

## C2014

LC02013A

R020022

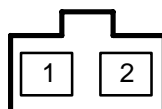

1	OW
2	B

## C2022

LC02021A

R050006

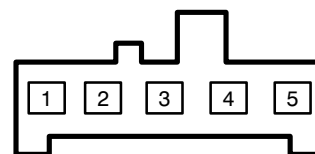

1	WB	4	PU
2	BO	5	N
3	G		

LC02014A

LC02022A

R040004

**C2023**

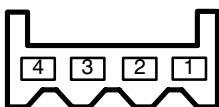

1	S	3	WB
2	UR	4	LG

R050002.02

**C2025**

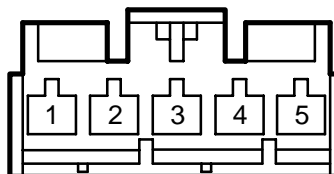

1	N	4	NW
2	LG	5	UR
3	WB		

LC02023A

R050002.02

**C2024**

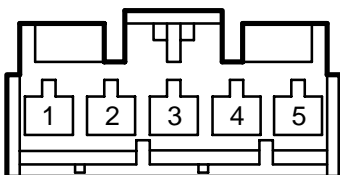

1	W	4	WB
2	LG	5	UW
3	-		

LC02025A

R050002.00

**C2026**

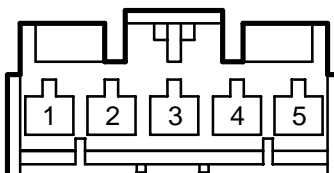

1	WB	4	RG
2	LG	5	UR
3	UB		

LC02024C

R050003

**C2027**

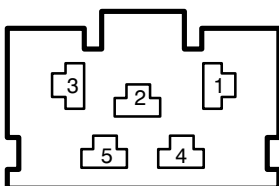

1	WB	4	G
2	N	5	BO
3	PU		

LC02026A

R050018

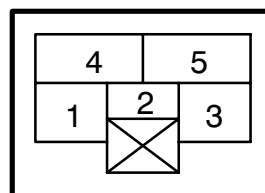

1	WB	4	G
2	N	5	BO
3	PU		

LC02027A

LC02027A

## C2028

R060007

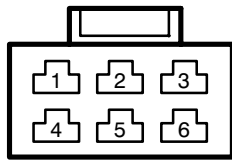

1	B	4	B
2	B	5	B
3	B	6	B

## C2035

R020032

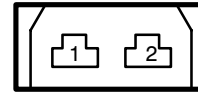

1	PW
2	P

## C2029

LC02028A

R060007

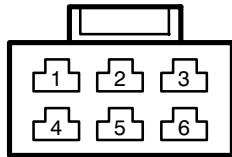

1	B	4	B
2	B	5	B
3	B	6	-

## C2036

LC02035A

R070001

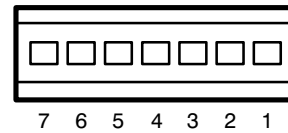

1	PB	5	YB
2	W	6	PB
3	R	7	PB
4	GR		

## C2031

LC02029A

R060007

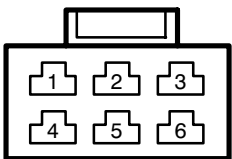

1	B	4	B
2	B	5	B
3	B	6	-

## C2051

LC02036A

R080019

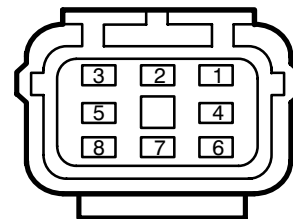

1	NK	5	NU
2	-	6	NLG
3	NK	7	PW
4	WP	8	NK

LC02031C

LC02051C

R060016

R180002

**C2052**

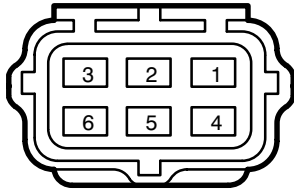

1	UP	4	U
2	WG	5	-
3	YN	6	-

**C2054**

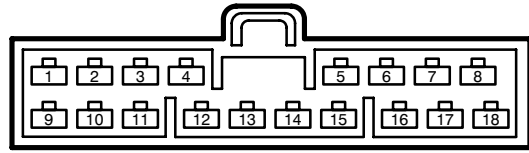

1	R	6	BK	11	B	16	BR
2	G	7	BW	12	B	17	BN
3	Y	8	BY	13	R	18	BO
4	U	9	LGP	14	PY		
5	BG	10	B	15	BU		

LC02052C

LC02054C

R050001

**C2053**

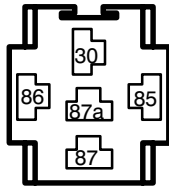

30	NK	86	B
85	LGO	87	LGP
87A	-		

LC02053C

R130008

**C2055**

R130004

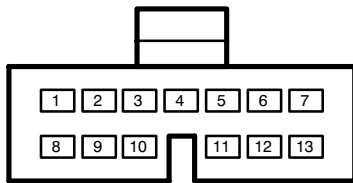

1	G/BG	6	BN	11	SCR
2	B/BU	7	U/BY	12	UY
3	R/BK	8	BO	13	B
4	BR	9	R		
5	Y/YB	10	B		

LC02055C

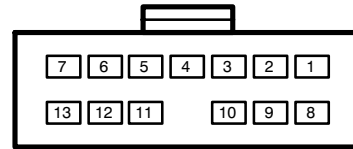

1	G/BG	6	BW/BN	11	SCR
2	B/BU	7	U/BY	12	PY
3	R/BK	8	BO	13	B
4	BR	9	R		
5	Y/BW	10	B		

LC02055C

## C2056

R050002.00

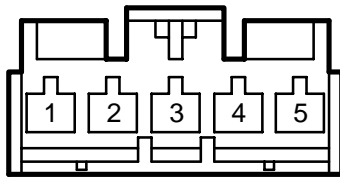

1	UG	4	B
2	RN	5	B
3	-		

## C2059

R050002.10

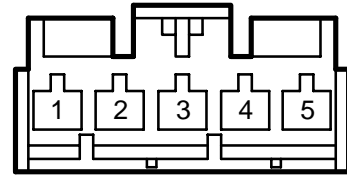

1	U	4	B
2	RN	5	B
3	-		

## C2057

LC02056C

R050002.10

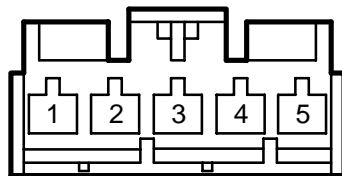

1	RG	4	B
2	RN	5	B
3	-		

## C2060

LC02059C

R050019

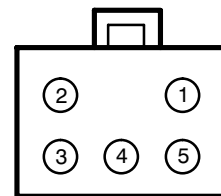

1	U	4	B
2	NY	5	UG
3	RK		

## C2058

LC02057C

R050002.00

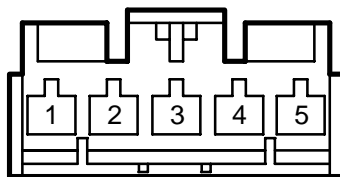

1	NY	4	B
2	RN	5	B
3	-		

## C2061

LC02060C

R070002

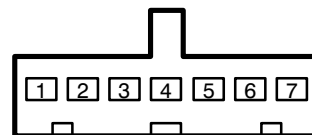

1	-	5	-
2	-	6	R
3	B	7	-
4	-		

LC02058C

LC02061C



R020010

**C2063**

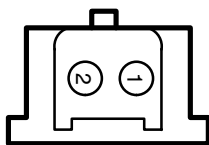

1	GP
2	GO

LC02063C

R080001

**C2066**

R080002

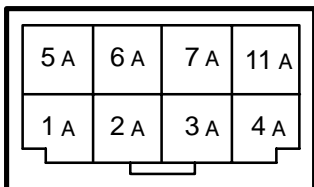

1	BO	5	UR
2	G	6	UB
3	PU	7	WB
4	N	8	RG

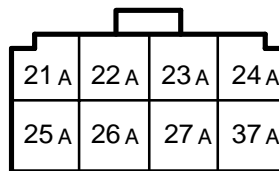

1	BO	5	UR
2	G	6	UB
3	PU	7	WB
4	N	8	RG

LC02066A

R100003

**C2067**

LC02066A

R100001

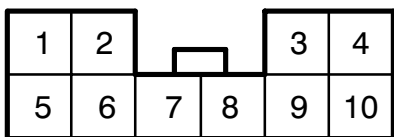

1	NW	4	S	6	UB	8	WB
2	N	5	RG	7	UW	9	W
3	LG					10	UR

LC02067A

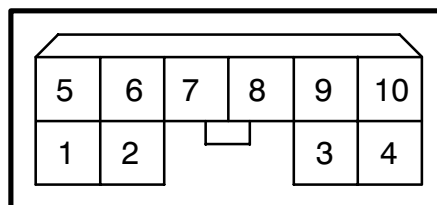

1	NW	4	S	6	UB	8	WB
2	N	5	RG	7	UW	9	W
3	LG					10	UR

LC02067A

R050016

### C2068

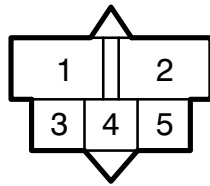

1	R	4	WB
2	WR	5	UR
3	N		

R020046

### C2071

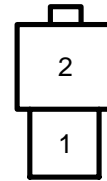

1	YB
2	UR

LC02068A  
R020049

### C2069

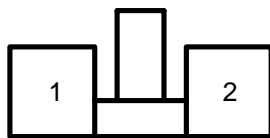

1	BO
2	WR

LC02071A  
R030015

### C2072

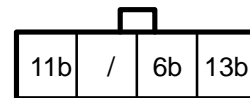

1	YB
2	UB
3	RG

LC02069A  
R040022

### C2070

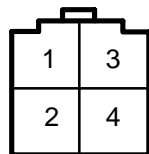

1	BO	3	PU
2	G	4	WB

LC02072A  
R100003

### C2073

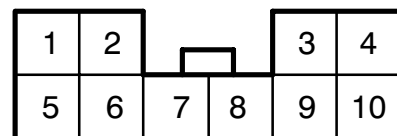

1	YO	4	PB	6	-	8	ON
2	RN	5	YU	7	WG	9	YB
3	B					10	YR

LC02070A

LC02073C

R050001

R030020

**C2074**

**C2075**

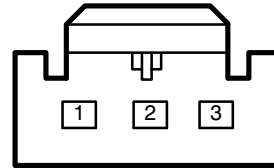
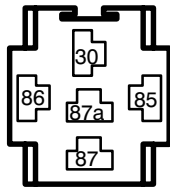

30	PU	86	BK
85	PU	87	LGR
87A	-		

1	B
2	-
3	GP

LC02074A

LC0275C

R060007

R060006

**C301**

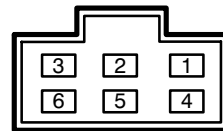
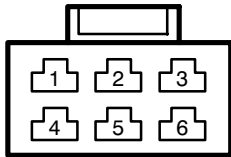

1	SG	4	SW
2	SG	5	SN
3	SO	6	S

1	SG	4	SW
2	SG	5	SN
3	SO	6	S

LC00301A

LC00301A

R030010

R030009

**C306**

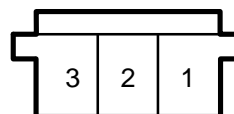

1	PW
2	O
3	K

1	PW
2	O
3	K

LC00306A

LC00306A

R350002

## C312

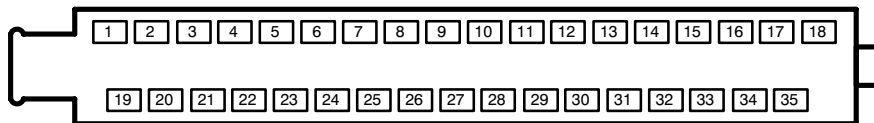

1	NK	6	SR	11	WO	16	W	21	SG	26	BS	31	B
2	-	7	SU	12	-	17	G	22	SP	27	B	32	G
3	-	8	BG	13	WK	18	W	23	SK	28	-	33	W
4	SY	9	WG	14	BK	19	NK	24	SN	29	-	34	G
5	SW	10	WS	15	G	20	-	25	GP	30	NR	35	W

LC00312C

R050009

## C323



1	-	4	BO
2	GY	5	BY
3	GN		

R030007

LC00323A

R030008

## C336

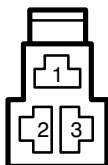

1	B
2	NR
3	WG



1	B
2	NR
3	WG

LC00336C

LC00336C

R070008

R070008

**C337**

**C340**

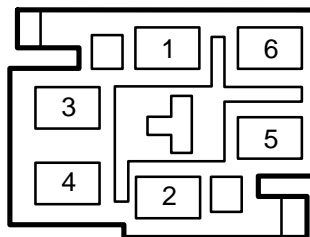
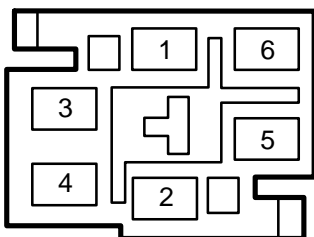

1	BS	5	-
2	BR	6	RN
3	-	7	-
4	B		

1	S	5	WK
2	SN	6	RN
3	WK	7	-
4	B		

LC00337A

LC00340C

R070008

R060019

**C338**

**C343**

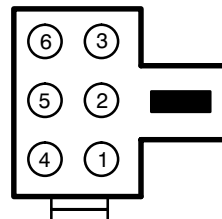
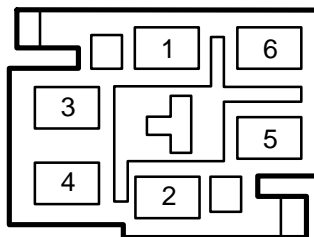

1	BU	5	-
2	BK	6	RN
3	-	7	-
4	B		

1	B	4	SG
2	-	5	-
3	-	6	-

LC00338A

LC00343A

R070008

R060016

**C339**

**C344**

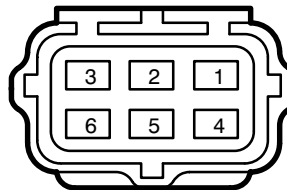
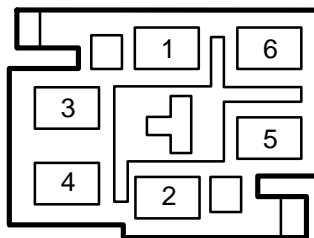

1	SW	5	WK
2	SO	6	RN
3	WK	7	-
4	B		

1	P	4	BR
2	GP	5	KS
3	B	6	KS

LC00339C

LC00344A

### C345

R060019

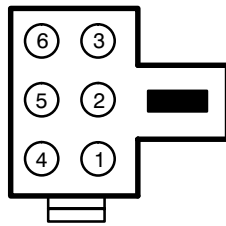

1	B	4	SG
2	-	5	-
3	-	6	-

### C351

R050001

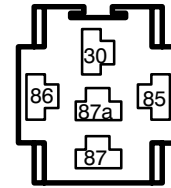

30	OK	86	BG
85	B	87	NK
87A	-		

### C346

LC00345C

R020033

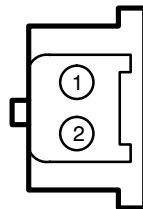

1	GLG/RG
2	B

### C352

LC00351C

R050001

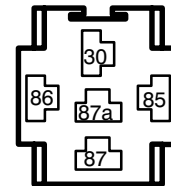

30	NO	86	WO
85	B	87	NR
87A	-		

### C350

LC00346C

R050001

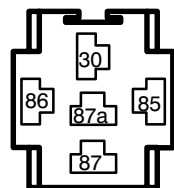

30	BS	87	-
86	NK	85	B
87A	B		

### C353

LC00352C

R020015

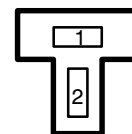

1	B
2	LGW

LC00350C

LC00353A

**C354**

R020007

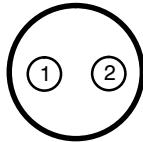

1	W
2	W

**C369**

R020037

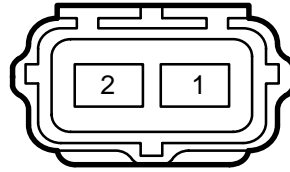

1	SB
2	B

**C355**

LC00354A

R020007

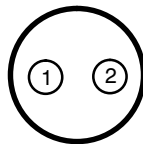

1	W
2	W

**C370**

LC00369A

R030003

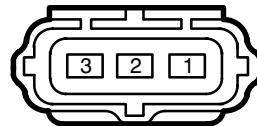

1	GY
2	-
3	BR

**C368**

LC00355A

R030021

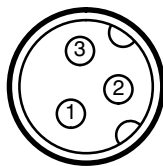

1	-
2	B
3	BK

**C371**

LC00370A

R020003

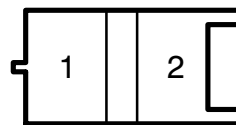

1	BLG
2	B

LC00368A

LC00371A

## C372

R020038

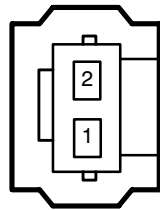

1	GN
2	GY

LC00372A

R020005

## C378

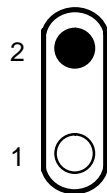

1	B
2	RW

LC00378C

R030018

## C381

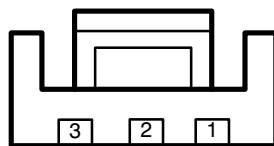

1	B
2	
3	P

LC00381C

## C382

R080008

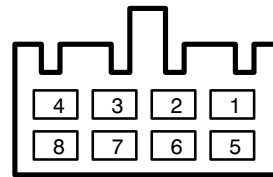

1		5	
2		6	GW
3	GO	7	GU
4	OG	8	OU

LC00382C

R100006

## C383

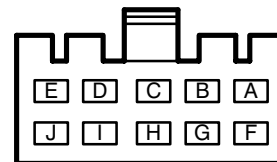

A	P	D	B	F	WG	H	GK
B	U	E	W	G	GB	I	GR
C	NR					J	O

LC00383C

R070008

## C384

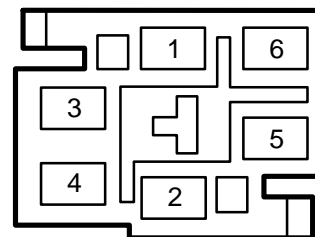

1	GO	5	
2	GR	6	
3		7	
4	B		

LC00384C



R070008

R040018

**C385**

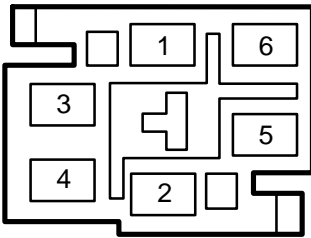

1	GU	5	
2	GK	6	
3		7	
4	B		

LC00385C

LC00388C

R050002.00

R030027

**C386**

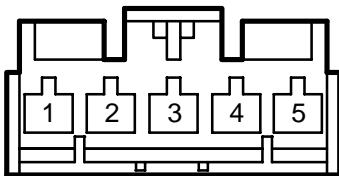

1	B	4	BS
2		5	
3			

LC00386C

LC00389C

R040018

R020033

**C387**

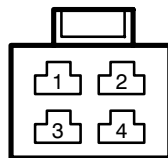

1	W	3	B
2	OU	4	P

LC00387C

LC00390C

**C388**

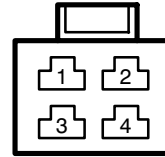

1	O	3	B
2	OG	4	U

**C389**

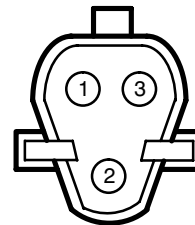

1	GW
2	GB
3	BS

**C390**

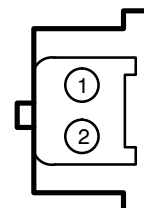

1	BS
2	

## C391

R050006

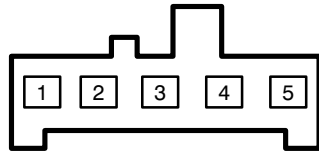

1	B	4	N
2	GR	5	BR
3	Y		

## C403

R060003

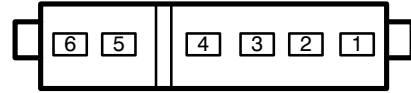

1	GP	4	B
2	GP	5	RY
3	-	6	GN

## C392

LC00391C

R050002.02

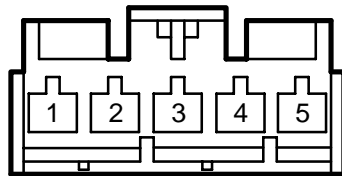

1	LGW	4	B
2	RB	5	UW
3			

## C406

LC00403C

R060003

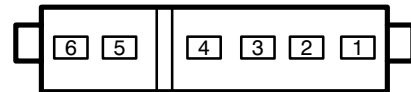

1	GP	4	B
2	GP	5	RY
3	-	6	GN

## C400

LC00392C

R070003

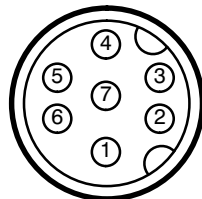

1	RO	5	B
2	GP	6	RY
3	GW	7	RB
4	GR		

LC00406C

LC00400A

R030001

R030003

**C407**

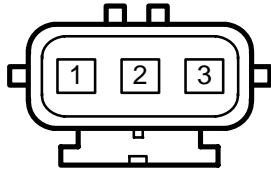

1	WP
2	GB
3	B

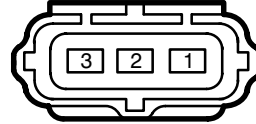

1	WP
2	GB
3	B

LC00407A

LC00407A

R040026

R040024

**C408**

**C411**

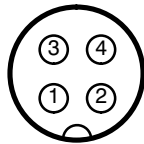

1	GO	3	NG
2	-	4	B

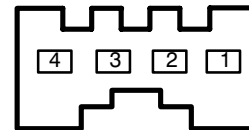

1	PN	3	B
2	PU	4	-

LC00408C

LC00411C

R030014

R060012

**C410**

**C412**

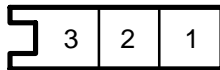

1	PU
2	-
3	PN

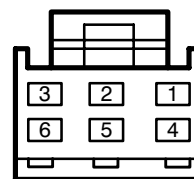

1	SCR	4	LGO
2	R	5	PY
3	B	6	B

LC00410C

LC00412C

## C414

R020031

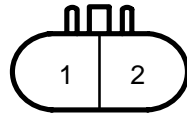

1	K
2	O

LC00414C

R080014

## C415

R080013

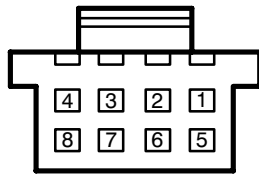

1	GLG	5	B
2	NG	6	O
3	RB	7	B
4	K	8	PW

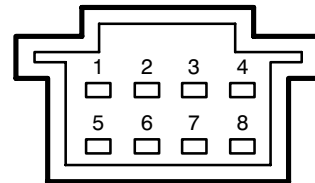

1	GO	5	B
2	NG	6	O
3	RB	7	B
4	K	8	-

LC00415C

R040001

LC00415C

## C434

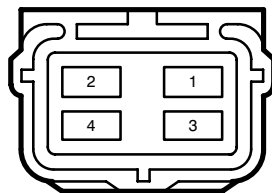

1	GB	3	B
2	B	4	WP

LC00434A

R060011

**C437**

R060010

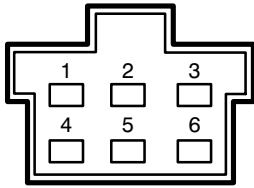

1	R	4	LGO
2	B	5	PY
3	SCR	6	GP

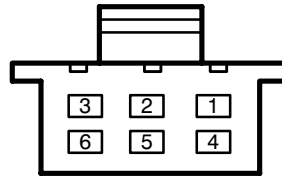

1	R	4	LGO
2	B	5	PY
3	SCR	6	GP

LC00437C

LC00437C

R020041

**C438**

R020018

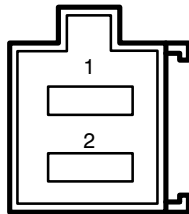

1	NP
2	B

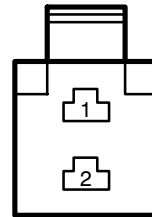

1	NP
2	B

LC00438C

LC00438C

R020037

**C442**

R020034

**C443**

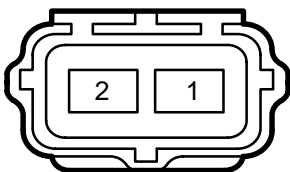

1	GR
2	B

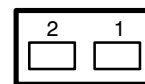

1	RB
2	B

LC00442C

LC00443C

## C444

R020037

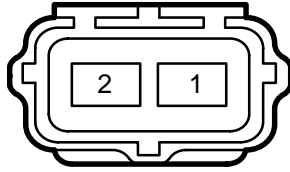

1	RO
2	B

## C445

R020037

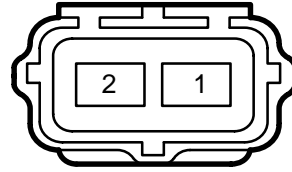

1	GW
2	B

LC00444C

LC00445C

R020050

R020014

## C447

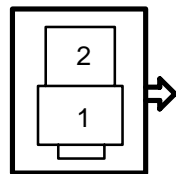

1	G
2	B

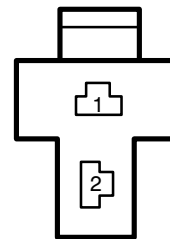

1	B
2	NG

LC00447C

LC00447C

R160001

R160005

## C448

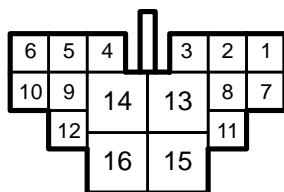

1	-	5	LGW	9	P	13	N
2	WG	6	BR	10	-	14	-
3	BG	7	-	11	-	15	Y
4	UW	8	W	12	UB	16	GR

LC00448C

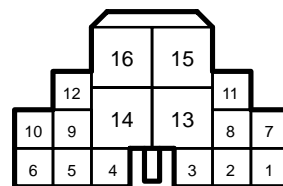

1	-	5	GW	9	V	13	BR
2	WG	6	BR	10	-	14	-
3	BG	7	-	11	-	15	Y
4	LW	8	YL	12	VG	16	G

LC00448C

**C457**

R050016

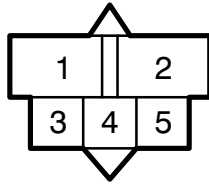

1	YG	4	B
2	NR	5	WG
3	VG		

**C462**

R020046

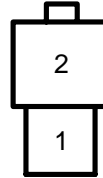

1	R
2	YG

LC00457C

LC00462C

R020047

R040023

**C458**

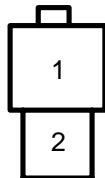

1	BRB
2	G

**C463**

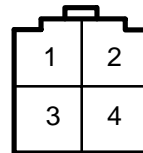

1	WG	3	LG
2	GR	4	B

LC00458C

LC00463C

R040022

R020048

**C459**

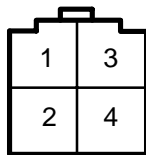

1	B	3	Y
2	BR	4	G

**C464**

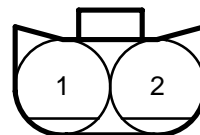

1	BG
2	RG

LC00459C

LC00464C

### C465

R040023

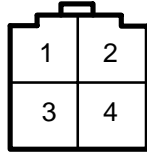

1	WG	3	G
2	WG	4	LW

### C483

R040006

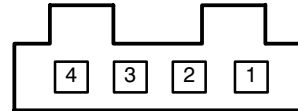

1	BN	3	WB
2	B	4	-

### C466

LC00465C

R040023

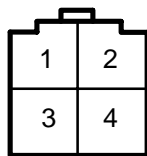

1	WG	3	G
2	VG	4	N

### C485

LC00483C

R030030

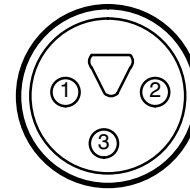

1	-
2	BW
3	BW

### C467

LC00466C

R060020

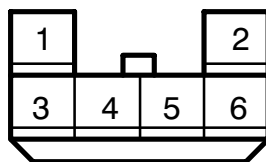

1	WG	4	GW
2	R	5	B
3	Y	6	LG

### C500

LC00485C

R020008

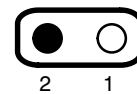

1	SU
2	SK

LC00467C

LC00500C



R020021

**C501**

R020021



1	SK
2	SU

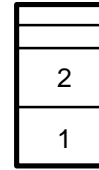

1	SR
2	SB

LC00501C

**C501**

LC00501C

R020001

R020021



1	SU
2	SK

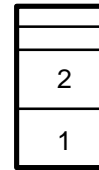

1	SR
2	SB

LC00501C

R060008

**C503**

LC00501C

R040016

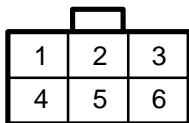

1	B	4	SW
2	BG	5	SW
3	BU	6	BK

**C504**

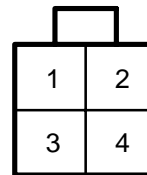

1	UG	3	-
2	-	4	B

LC00503C

LC00504C

R020053

R040011

### C507

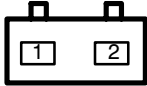

1	O
2	K

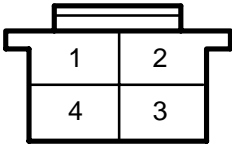

1	O	3	NK
2	K	4	B

LC00507C

LC00507C

### C507

R060009

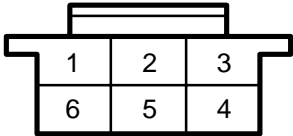

1	O	4	-
2	K	5	YK
3	B	6	-

LC00507C

R020030

R020028.00

### C510

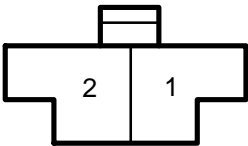

1	BN
2	BW

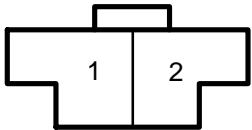

1	BW
2	B

LC00510C

LC00510C

R020008

**C600**

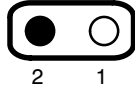

1	SU
2	SK

LC00600C

R020021

R020021

**C601**



1	SK
2	SU

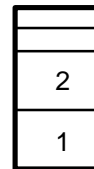

1	SR
2	SB

LC00601C

R020001

LC00601C

R020021

**C601**



1	SU
2	SK

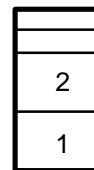

1	SR
2	SB

LC00601C

LC00601C

## C603

R060008

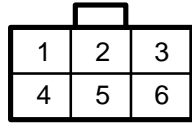

1	B	4	SW
2	BG	5	SW
3	BU	6	BK

## C604

R040016

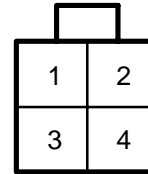

1	UG	3	-
2	-	4	B

LC00603C

LC00604C

R020053

R040011

## C607

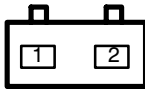

1	O
2	K

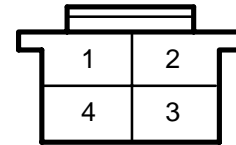

1	O	3	NK
2	K	4	B

LC00607C

LC00607C

R060009

## C607

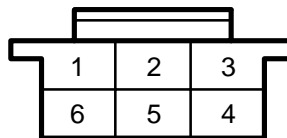

1	O	4	-
2	K	5	YK
3	B	6	-

LC00607C

R020030

R020028.00

**C610**

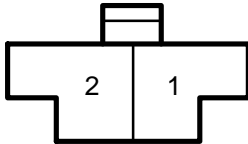

1	BN
2	BW

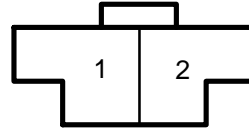

1	BW
2	B

LC00610C

LC00610C

R030006

R030007

**C700**

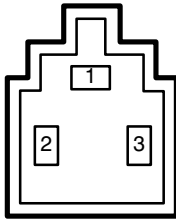

1	SG
2	SW
3	SO

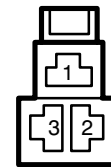

1	SG
2	SW
3	SO

LC00700C

LC00700C

R020012

R020028.01

**C701**

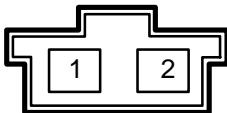

1	O
2	K

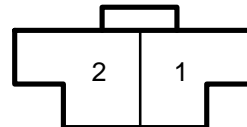

1	O
2	K

LC00701C

LC00701C

## C703

R030021

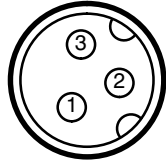

1	-
2	SW
3	SO

LC00703C

## C709

R050008

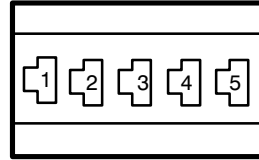

1	SO	4	SW
2	SO	5	SW
3	SG		

LC00704C

## C706

R020029

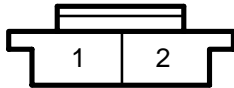

1	O
2	K

LC00706C

## C800

R030006

R030008

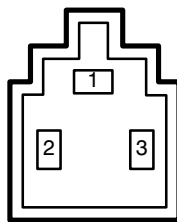

1	SG
2	SN
3	S

LC00800C

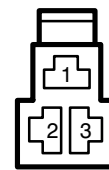

1	SG
2	SN
3	S

LC00800C

R020012

R020028.01

**C801**

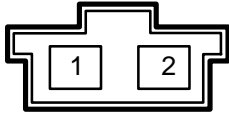

1	O
2	K

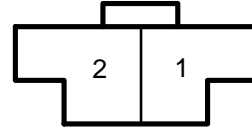

1	O
2	K

LC00801C

LC00801C

R030021

R050008

**C803**

**C809**

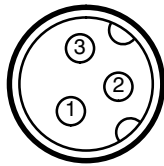

1	-
2	SW
3	SO

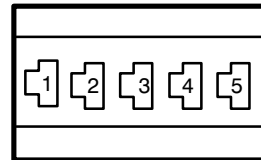

1	SW	4	SN
2	S	5	SO
3	SG		

LC00803C

LC00809C

R020029

**C806**

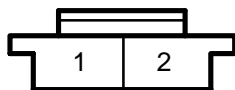

1	O
2	K

LC00806C

R200001

### HJ1

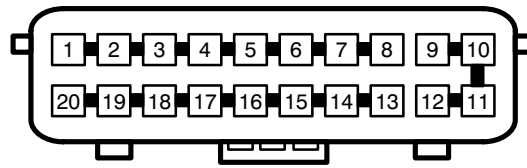

#### S2042

1	GO
2	GO
3	GO
4	GO
5	GO
6	-
7	-
8	-

#### S274

13	GLG
14	GLG
15	GLG
16	GLG
17	GLG
18	GLG
19	GLG
20	-

LC00HJ1G  
R200001

### HJ2

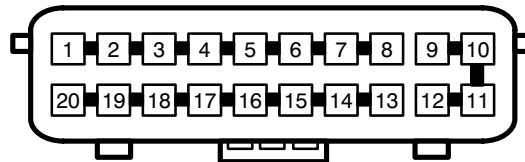

#### S2074

1	RN
2	RN
3	RN
4	RN
5	-
6	-

#### S2005

17	BY
18	BY
19	BY
20	BY

LC00HJ2G  
R200001

### HJ3

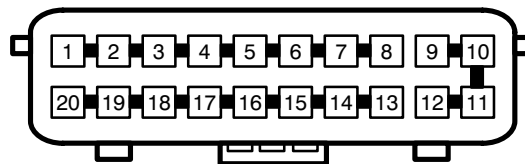

#### S238

1	B
2	-
3	B
4	B
5	B
6	-
7	B
8	B

#### S2032

9	B
10	BO
11	BO
12	B

#### S2003

13	B
14	-
15	B
16	B
17	-
18	-
19	-
20	B

LC00HJ3G



R200001

**HJ4**

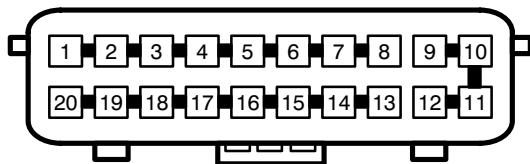

**S2055**

1	GP
2	-
3	GP
4	GP
5	GP
6	GP
7	GP
8	GP

**S2014**

9	WP
10	WP
11	WP
12	WP

**S2011**

13	-
14	GP
15	GP
16	GP
17	GP
18	GP
19	GP
20	GP

LC00HJ4G  
R200001

**HJ5**

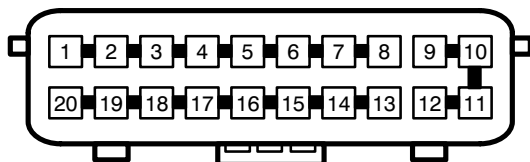

**S2031**

1	B
2	-
3	B
4	B
5	B
6	B
7	B
8	-

**S2017**

9	-
10	-
11	GK
12	GK

**S288**

13	B
14	B
15	B
16	B
17	-
18	B
19	-
20	B

LC00HJ5G  
R200009

**HJ6**

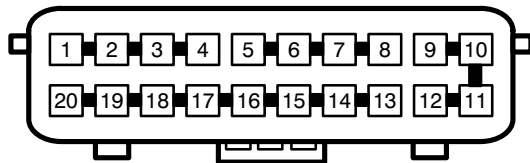

**S2019**

1	GW
2	GW
3	GW
4	GW

**S2020**

5	GR
6	GR
7	GR
8	GR

**S2018**

9	BR
10	BR
11	BR
12	BR

**S2021**

13	P
14	P
15	-
16	P
17	P
18	-
19	P
20	-

LC00HJ6G

R200010

### HJ7

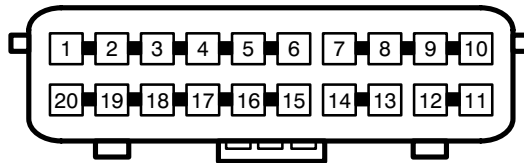

#### S290

1	BS
2	B
3	BS
4	BS
5	-
6	BS

#### S291

7	NO
8	NO
9	NO
10	NO

#### S292

11	WG
12	WG
13	WG
14	WG

#### S293

15	RB
16	RB
17	RB
18	RB
19	RB
20	-

LC00HJ7C

R200001

### HJ8

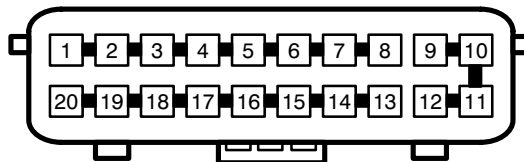

#### S253

1	B
2	B
3	B
4	B
5	B
6	B
7	B
8	B

#### S252

9	RO
10	RO
11	RO
12	RO

#### S255

13	B
14	B
15	B
16	B
17	B
18	B
19	B
20	B

LC00HJ8C

R200001

### HJ9

LC00HJ2F

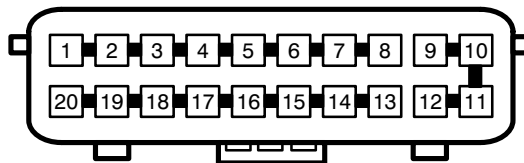

#### S256

1	RO
2	RN
3	RN
4	RN
5	RN
6	RN
7	RN
8	RN

#### S251

13	RN
14	RN
15	RN
16	RN
17	RN
18	RN
19	RN
20	RN

LC00HJ9C

LC00HJ2F

R200001

**HJ10**

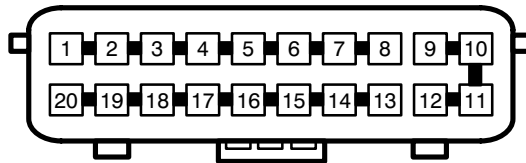

**S204**

1	B
2	B
3	B
4	B
5	B
6	B
7	B
8	B

**S2016**

13	B
14	B
15	B
16	B
17	B
18	B
19	B
20	B

LC0HJ10G

R200001

**HJ11**

LC00HJ2F

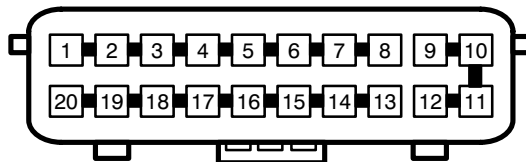

**S2033**

1	B
2	B
3	B
4	B
5	B
6	-
7	B
8	B

**S2015**

13	B
14	B
15	-
16	B
17	-
18	B
19	B
20	B

LC0HJ11G

LC00HJ2F

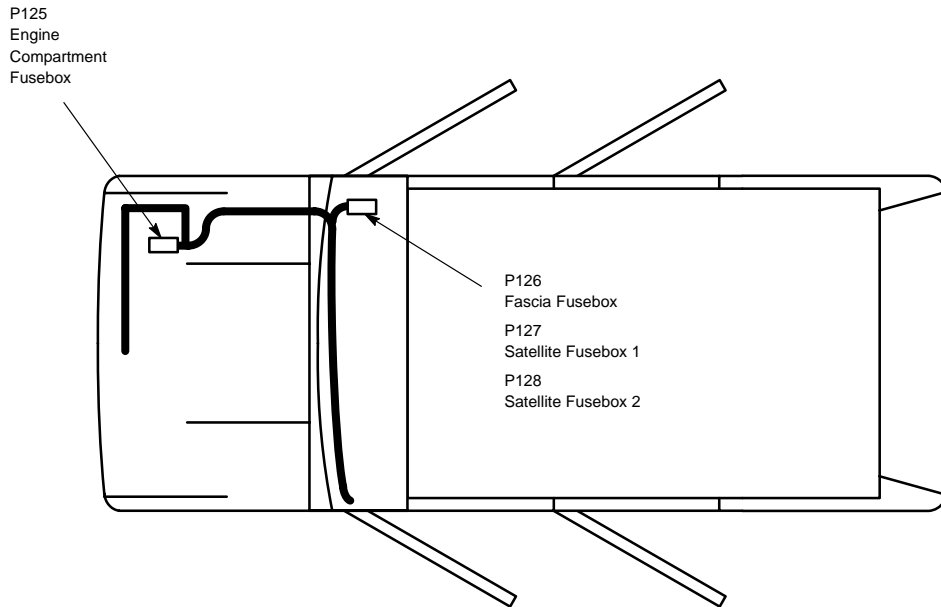

**Main Harness (Partial)**

